

(19) World Intellectual Property  
Organization  
International Bureau



(43) International Publication Date  
6 October 2005 (06.10.2005)

PCT

(10) International Publication Number  
**WO 2005/092218 A1**

(51) International Patent Classification<sup>7</sup>: **A61B 17/56**

(21) International Application Number:  
PCT/US2004/031860

(22) International Filing Date:  
29 September 2004 (29.09.2004)

(25) Filing Language: English

(26) Publication Language: English

(30) Priority Data:  
10/789,149 27 February 2004 (27.02.2004) US

(71) Applicant and

(72) Inventor: JACKSON, Roger, P. [US/US]; 2750 Clay Ed-  
wards Drive, Suite 600, North Kansas City, MO 64116-  
3250 (US).

(74) Agent: McMAHON, John, C.; P.O. Box 30069, Kansas  
City, MO 64112 (US).

(81) Designated States (unless otherwise indicated, for every  
kind of national protection available): AE, AG, AL, AM,

AT, AU, AZ, BA, BB, BG, BR, BW, BY, BZ, CA, CH, CN,  
CO, CR, CU, CZ, DE, DK, DM, DZ, EC, EE, EG, ES, FI,  
GB, GD, GE, GH, GM, HR, HU, ID, IL, IN, IS, JP, KE,  
KG, KP, KR, KZ, LC, LK, LR, LS, LT, LU, LV, MA, MD,  
MG, MK, MN, MW, MX, MZ, NA, NI, NO, NZ, OM, PG,  
PH, PL, PT, RO, RU, SC, SD, SE, SG, SK, SL, SY, TJ, TM,  
TN, TR, TT, TZ, UA, UG, US, UZ, VC, VN, YU, ZA, ZM,  
ZW.

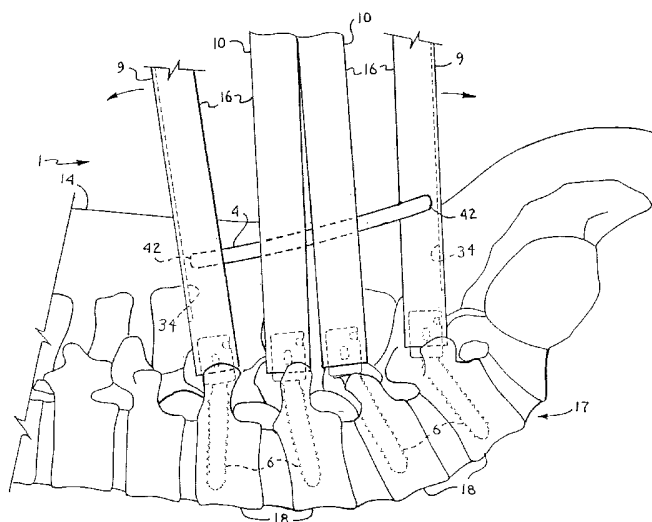
(84) Designated States (unless otherwise indicated, for every  
kind of regional protection available): ARIPO (BW, GH,  
GM, KE, LS, MW, MZ, NA, SD, SL, SZ, TZ, UG, ZM,  
ZW), Eurasian (AM, AZ, BY, KG, KZ, MD, RU, TJ, TM),  
European (AT, BE, BG, CH, CY, CZ, DE, DK, EE, ES, FI,  
FR, GB, GR, HU, IE, IT, LU, MC, NL, PL, PT, RO, SE, SI,  
SK, TR), OAPI (BF, BJ, CF, CG, CI, CM, GA, GN, GQ,  
GW, ML, MR, NE, SN, TD, TG).

Published:

— with international search report

For two-letter codes and other abbreviations, refer to the "Guid-  
ance Notes on Codes and Abbreviations" appearing at the begin-  
ning of each regular issue of the PCT Gazette.

(54) Title: ORTHOPEDIC IMPLANT ROD REDUCTION TOOL SET AND METHOD



(57) Abstract: A tool set for implanting a rod in a human spine in conjunction with bone screws. The tool set includes a pair of end guide tools that receive opposite ends of the rod in channels and under manipulation by a surgeon facilitate transport of the rod toward the bone screws attached to the guide tools. Intermediate guide tools having guiding pass through slots are utilized to guide intermediate locations along the rod toward associated bone screws. An attachment structure operably connects the guide tools to the bone screws. The guide tools each include a lower guide and advancement structure to allow a closure top with mating structure to be rotated and driven downward against the rod and to cooperate with similar structure in the bone screw to seat and lock the rod therein. A method utilizing the tool set allows a surgeon to percutaneously implant the rod in the patient.

WO 2005/092218 A1

## ORTHOPEDIC IMPLANT ROD REDUCTION TOOL SET AND METHOD

Background of the Invention

[0001] The present invention relates to apparatuses and methods for use in performing spinal surgery and, in particular, to tools and methods of using such tools, especially for percutaneously implanting a rod for spinal support and alignment using minimally invasive techniques.

[0002] For many years, spinal osteosynthesis apparatuses have been utilized to correct spinal deformities, injuries or disease. In such procedures, elongate rods are surgically attached to vertebrae of the spine to provide support and/or to reposition certain vertebrae. Such rods are secured to vertebrae utilizing bone screws and other implants.

[0003] Surgical techniques and bone screws have improved; however, in order to reduce the impact of such surgery on the patient, it has been desirable for such implants to be inserted percutaneously or with surgical techniques that are minimally invasive to the body of the patient. This presents a problem with implantation of rods that are elongate and have historically required a long incision and open wound in order to provide for the length of the rod and the space required for the surgeon's hands to manipulate the rod, implants and

insertion tools used with the rod. Consequently, it has been desirable to develop apparatuses and techniques that allow for the insertion of bone screws, the insertion and reduction of a rod and the securing of the rod to the bone screws with significantly reduced invasion into the body of the patient and with minimal incision size in the skin over the operational site.

#### Summary of the Invention

[0004] A set of tools is provided for percutaneously implanting a spinal rod in a patient. The tools include a pair of end guide tools that have channels sized to receive opposite ends of such a rod and allow sliding of the rod along the channel so as to guide ends of the rod into opposed end bone screw-heads to which the end guide tools are attached. Intermediate guide tools are also attached to bone screw-heads between the end bone screws and are slotted to guide the rod to respective bone screws attached to the intermediate guide tools.

[0005] The guide tools also include lower attachment structure to allow the guide tools to be easily and quickly secured to mating structure on a respective bone screw-head, and to be easily removed from the bone screw by manual rotation of a handle of the tools exterior of the patient, after which the guide tool is withdrawn from the patient. The intermediate guide tools have a snap-on

and twist-off association with an associated intermediate bone screw and the end guide tools have a twist-on and twist-off association with respective end bone screws. In certain embodiments, other attachment structure may be used.

[0006] Each of the guide tools also includes an internal first lower guide and advancement structure that functions in cooperation with an internal second guide and advancement structure within the bone screw head and also with external helical wound thread or locking flange form mating structure on a bone screw closure top for closing the head of the bone screw, so as to be able to load the closure top through a top-to-bottom passageway in the guide tool and rotate the closure top with a closure top installation tool. Beneath the surface of the skin, the closure top is partially surrounded by the guide tool as it is directed to the bone screw. Clockwise rotation of the closure top in the region of the lower guide and advancement structure engages the closure top therewith and produces mechanical advantage that causes the closure top to be driven against the rod as it advances thereby urging the rod into the head of a respective bone screw. The closure top is driven and advanced by rotation of the closure top by the closure top installation tool and transferred or passed from the first guide and advancement structure in the guide tool to the second guide and advancement structure in the bone screw

without losing mechanical advantage and while continually applying downward pressure on the rod, so as to drive the closure top downward and against the rod and so as to bias the rod into the head of the bone screw where it is captured by the closure top and locked in position.

Objects and Advantages of the Invention

[0007] Therefore, the objects of the present invention are: to provide a set of tools for implanting a spinal rod for support or alignment along a human spine with minimal surgical invasion of the patient; to provide such a set of tools including a pair of end tool guides for slidably guiding opposed ends of the rod toward end bone screws attached to the end guide tools; to provide such a set of tools including intermediate guide tools for each intermediate bone screw that guide the rod in slots therethrough to respective bone screws; to provide such a set of tools including rod pusher and closure top installation tools for assisting in securing the rod in the bone screws; to provide such a set of tools where the end guide tools include a longitudinal channel extending upwardly from near a bottom thereof to slidably receive and guide ends of the rod toward associated end bone screws; to provide such a set of tools wherein the guide tools are easily attached to and disengaged from the bone screws; to provide such a set of tools wherein each guide

tool includes a first guide and advancement structure near the bottom thereof that receives thread or locking flange mating structure on the closure top and advances the closure top upon rotation of the closure top to urge the rod downwardly; to provide such a set of tools wherein the guide tool first guide and advancement structure acts cooperatively with a second guide and advancement structure on the bone screw so as to transfer the closure top upon rotation thereof from the guide tool to the bone screw while continuously applying pressure to the rod and thereafter further advance the closure top to urge the rod into a seated position in the bone screw; to provide such a set of tools wherein the guide tools easily attach to and disengage from the bone screws by manual manipulation of the surgeon outside the patient's skin; to provide a method of implanting a rod into a patient with minimal surgical invasion of the patient; to provide such a method utilizing the previously described tools for percutaneous implantation of such a rod; to provide such a method wherein end guide tools are utilized to receive opposite ends of a rod and guide the rod ends in the guide tool channels through manipulation of the guide tools and use of rod pusher tools; to provide such a method wherein intermediate guide tools are utilized to guide intermediate locations along the rod to respective intermediate bone screws; to provide such a method wherein guide and advancement structure

near the bottoms of the guide tools, on the bone screws and on the closure tops are utilized to pass the closure top under rotation and with driving force between the guide tools and the bone screws and to drive the rod into a seating position in the bone screw; and to provide such a set of tools and methods that are easy to use and especially adapted for the intended use thereof and wherein the tools are comparatively inexpensive to produce.

[0008] Other objects and advantages of this invention will become apparent from the following description taken in conjunction with the accompanying drawings wherein are set forth, by way of illustration and example, certain embodiments of this invention.

[0009] The drawings constitute a part of this specification and include exemplary embodiments of the present invention and illustrate various objects and features thereof.

Brief Description of the Drawings

[0010] Figure 1 is a fragmentary front elevational view of an intermediate guide tool in accordance with the present invention.

[0011] Figure 2 is a fragmentary side elevational view of the intermediate guide tool.

[0012] Figure 3 is a fragmentary cross sectional view of the intermediate guide tool, taken along line 3-3 of Fig. 1.

[0013] Figure 4 is a fragmentary front elevational view of an end guide tool.

[0014] Figure 5 is a fragmentary side elevational view of the end guide tool.

[0015] Figure 6 is a cross sectional view of the end guide tool, taken along line 6-6 of fig. 4.

[0016] Figure 7 is an enlarged and fragmentary front elevational view showing snap-on installation of the intermediate guide tool on a polyaxial bone screw head.

[0017] Figure 8 is an enlarged and fragmentary front elevational view showing the intermediate guide tool installed on the bone screw head.

[0018] Figure 9 is a fragmentary and cross-sectional view showing an early stage of the snap on installation of the intermediate guide tool on the bone screw head.

[0019] Figure 10 is a fragmentary and cross-sectional view showing a later stage of installation of the intermediate guide tool on the bone screw head.



[0020] Figure 11 is a fragmentary and cross-sectional view showing the intermediate guide tool installed on the bone screw head.

[0021] Figure 12 is a partial and generally schematic view of a patient's spine with the end guide tool in conjunction with a bone screw installation tool, at the end of a process of installing a bone screw with attached end guide tool in a spinal vertebra.

[0022] Figure 13 is a partial and generally schematic view of the spine with a pair of end guide tools and a pair of intermediate guide tools mounted on respective implanted bone screws and being utilized in an early stage of rod implantation to guide the rod toward the bone screws.

[0023] Figure 14 is a view similar to Fig. 13 showing an intermediate stage of guiding the rod toward the bone screws.

[0024] Figure 15 is a view similar to Fig. 13 showing a later intermediate stage of guiding the rod toward the bone screws.

[0025] Figure 16 is a partial and generally schematic cross sectional view of the spine showing rods being implanted on opposite sides of the spine and with the rod on the left in an early stage of implanting while the rod on the right is in a later stage of implanting, taken along line 16-16 of Fig. 15.

[0026] Figure 17 is a cross-sectional view of an end guide tool, similar to Fig. 6, shown during installation of the rod and a closure top in the bone screw attached to the end guide tool.

[0027] Figure 18 is a view similar to Fig. 17 showing the rod and closure top installed in the bone screw before final torquing of the closure top.

[0028] Figure 19 is a partial and generally schematic side view of the spine showing the rod fully installed in the bone screws.

[0029] Figure 20 is an exploded and front elevational view of a closure top installation tool, antitorque tool and one of the intermediate guide tools attached to a bone screw.

[0030] Figure 21 is a fragmentary and front elevational view of the antitorque tool being positioned so as to allow final torquing to a closure top in the bone screw.

[0031] Figure 22 is an enlarged and fragmentary side view of the end guide tool, as shown in Fig. 21, in conjunction with the installation tool and antitorque tool with portions broken away to shown interior detail and with the closure top having just been installed and torqued in the bone screw so that a break away head of the closure top has been removed.

[0032] Figure 23 is a fragmentary and enlarged front elevational view showing an early stage in the removal of

the end guide tool from the bone screw wherein the tool has been rotated approximately ninety degrees relative to its axis to the shown removal configuration from the installation configuration, such as seen in Fig. 17, thereof.

[0033] Figure 24 is a fragmentary and enlarged front elevational view showing the end guide tool disengaged from the bone screw.

#### Detailed Description of the Invention

[0034] As required, detailed embodiments of the present invention are disclosed herein; however, it is to be understood that the disclosed embodiments are merely exemplary of the invention, which may be embodied in various forms. Therefore, specific structural and functional details disclosed herein are not to be interpreted as limiting, but merely as a basis for the claims and as a representative basis for teaching one skilled in the art to variously employ the present invention in virtually any appropriately detailed structure.

[0035] The reference numeral 1 generally designates a tool set for use in installing an orthopedic spinal rod 4 into a set of bone screws 6 in accordance with the present invention.

[0036] The tool set 1 of the illustrated embodiment includes a pair of end guide tools 9 and a plurality of intermediate guide tools 10, which in the illustrated embodiment includes a pair of intermediate guide tools 10 on each side of a patient's spine 17, but which can include none, one or many intermediate guide tools 10 depending upon the particular application, so that one intermediate guide tool 10 is used for each intermediate bone screw 6 to which the rod 4 is to be attached. The bone screws 6 are implanted in the patient's spine 17 and, in particular, in vertebrae 18 along the spine 17. Rods 4 are often installed on both sides of the spine 17, as seen in Fig. 16, during the same procedure.

[0037] The end guide tool 9 is illustrated in Figures 4 through 6. In particular, each end guide tool 9 has an elongate body 14 that is sized and shaped to be sufficiently long to extend from implanted bone screws 6 through an exterior of a patient's skin 14 so as to provide an outwardly extending and upper handle portion 16 that allows and provides for gripping by a surgeon during procedures utilizing the tool set 1. Each of the end guides 9 include an intermediate portion 19 and a lower portion 20 along the length thereof. Each end guide tool 9 has a back wall 21 joining a pair of side walls 22 and 23.

[0038] More specifically, the upper portion 16 of each end guide tool 9 is generally channel shaped having a U-

shaped cross-section, a C-shaped cross-section, a crescent shaped cross-section or the like in order to form an opening 24 that opens into and forms part of a channel 25 that opens radially to one side of the end guide tool 9 and defines the side to side opening 24 that is sufficiently wide to receive additional tools and/or a closure top, as will be discussed below. The intermediate portion 19 of each end guide also includes an outward facing channel 29 that has an opening 26 which is somewhat smaller than the opening 24 of the upper portion 16, such that the channel 29 is sized and shaped to receive certain tools, as described below. Finally, the end guide lower portion 20 also includes a groove or channel 34 opening radially outward and having a side-to-side width or opening 35 that is approximately the same size as the opening 26. The channel 34 has a rear web or wall 36 having a lower end 37. All of the channels 25, 29 and 34 communicate with one another and are aligned with one another so as to provide a continuous elongate interior passageway with an open side from near a top 38 to near a bottom 39 thereof. This passageway provides a continuous open path of non uniform cross-section radius from the top 38 to the bottom 39 thereof that is parallel to an elongate axis A of each end guide tool 9. As will be discussed later, each end guide tool channel 34 is especially sized and shaped to slidingly receive a respective end 42 of the rod 4 therein.

[0039] Near the end guide bottom 39 is a cut out 45 wherein a portion of the back wall 21 of the channel 34 is removed in order to provide a region having a size and shape to allow passage of a respective end 42 of the rod 4 therethrough. Also located near the end guide bottom 39 is a rod abutment recess 49 that is sized and shaped for the purpose of bridging the rod 4 when the end guide tool 9 is rotated for removal, as described below. The end guide tool 9 also receives a closure top 52, as will be described below. Still further, near the bottom 39 of each of the end guides 9 is a helical wound first guide and advancement structure 50 which may include conventional helical threads, helically wound square threads, or other guide and advancement structure to cooperate with equivalent or mateable structure within the bone screw heads 6 and on the closure top 52, as also described below. The lower free ends of the side walls 22 and 23 form spaced tangs or legs 53 and 54.

[0040] At the bottom 39 of each end guide tool 9 is a radially inward facing attachment structure 55 that includes a base 56 and an upperly and axially extending projection, flange or hook member 57 which will be described in conjunction with a bone screw 6 below.

[0041] Referring more specifically to the bone screw 6, each of the bone screws 6 includes a threaded shank 60 for screwing into and seating in a vertebra 18 that is part of the human spine 17, see Fig. 12. Each of the

bone screws 6 also include a head 66 with a rod receiving channel 67 passing therethrough. Each of the bone screw shanks 60 includes an upper portion 70 that extends into the head 66 and is operationally secured therein, so that the head 66 is rotatable on the shank 60 until locked in position through engagement with the rod 4 under pressure. In particular, each shank upper portion 70 has an upwardly extending dome 71 that engages the rod 4, when the rod 4 is placed within an associated channel 67 so that as the rod 4 urges the dome 71 downwardly, the shank upper portion 70 frictionally locks the shank 60 in position in a fixed angular position relative to the head 66. Many different conventional bone screws where the head locks relative to the shank are well known in the art.

[0042] The present invention is not intended to be restricted to a particular type of bone screw. In the present embodiment, a polyaxial type bone screw 6 is utilized wherein the shank 60 is locked in position by direct contact with the rod 4. It is foreseen that tool set 1 of the present invention can be used with virtually any type of bone screw, including polyaxial bone screws of many different types wherein the head is locked relative to the shank by structure other than in the manner described in the illustrated embodiment.

[0043] Each bone screw head 66 has a pair of upstanding arms 74 and 75 with internal second guide and

advancement structure 76 on the insides thereof. One of the arms 74 includes a circumferentially located receiver 78 that comprises a lower slot 79 that extends partially circumferentially about the periphery of the arm 74 and ends in an upperwardly projecting but hidden recess 80. While the slot 79 is located on the arm 74 in the illustrated embodiment, a slot for this purpose could be located anywhere on the bone screw head 66. The slot 79 and recess 80 are sized, shaped and positioned so as to receive the attachment structure 55 of the end guides 9 therein. For greater detail, see the description below for the attachment structure associated with intermediate guide tools 10 and shown in Figs. 10 and 11. The guide tool attachment structure 55 is sized and shaped to allow the attachment structure 55 to be received in the receiver 78 and locked therein by pulling the end guide tool 9 slightly axially upward relative to a respective bone screw 6. In order to disengage the guide tool 9 from the bone screw 6, the guide tool 9 is rotated 90 degrees counterclockwise from an attaching configuration, when viewing from the top so as to disengage the hook 57 from the recess 80 and so that the base 56 and hook 57 of the attachment structure 55 free to rotate above the rod 4 and closure top 52 and be released from the receiver 78. In this manner, end guide tools 9 twist off of respective bone screws 6 and in the particular illustrated embodiment the end guide tools 9 are also



assembled on the bone screws 6 by the opposite twist on maneuver is the reverse of the twist off maneuver. In certain embodiments where there is enough flexibility in the legs 53 and 54, such that the legs 53 and 54 can be splayed radially outwardly at the bottom 39 thereof in the manner shown in Fig. 7, so the end guide tool 9 snaps-on over the bone screw 6, as will be described for the intermediate guide tools 10 below.

[0044] The unflexed space between the legs 53 and 54 that is equivalent to the width of the opening 35 is preferably substantially equivalent to the space between the bone screw arms 74 and 75 so that the channel 34 of the end guide tool 9 aligns with the channel 67 of the bone screw 6 when the end guide tool 9 is mounted on a respective bone screw 6. The recess 49 is sized, shaped and positioned so that when the rod 4 is located in the bone screws 6, the end guide tool 9 can rotate about axis A and the recess 49 allows the end guide tool 9 to straddle over the rod 4, thereby allowing the end guide tool 9 to twist relative to the bone screw 6 and free the attachment structure 55 from the receiver 78 and thereafter be removed after all procedures are complete, as described below.

[0045] Each of the intermediate guide tools 10 (see especially Figs. 1 to 3) have a somewhat similar overall shape when compared to the end guide tools 9 in that both are preferably of the same axial length and width and

also have much structure in common; however with certain differences as noted. Many of the structures of the intermediate guide tools 10 that are the same as the end guide tools 9 are given the same reference number and the above noted description applies to each such tool 9 or 10.

[0046] Each intermediate guide tool 10 has an overall elongate body 84 with an upper portion 86, an intermediate portion 87 and a lower portion 88. In the upper portion 86, the body 84 is generally C-shaped having a radially outward opening and elongate and axially extending channel 90 terminating in a web or rear wall 91 with side walls 92 and 93. The channel 90 has a front opening 95 that extends parallel to an axis of the body 84 and that is sized and shaped to receive tools and elements described below.

[0047] The intermediate portion 87 also includes an outwardly opening channel 97 with a rear web or wall 98 having a lower end 100 and a front opening 99 that is not as wide as the opening 95. The lower portion 88 includes two spaced side walls or legs 93 and 94 with an elongate and axially extending passthrough opening 101 between the legs 93 and 94 that extends more than half way along the intermediate tool 10 and near the intermediate portion 87. The legs 93 and 94 define between them a pass through and aligned slot 105 sized and shaped to slidably receive the rod 6.

[0048] The lower portion 88 extends substantially axially along the intermediate guide tools 10 and preferably to the location in use where the intermediate guide tools 10 pass through the skin 14.

[0049] The bottom 39 of each intermediate guide tool 10 includes a helically wound but discontinuous square thread or first guide and advancement structure 109 that cooperates with the closure top 52, as described below. The lower end of each intermediate guide tool 10 also includes a cutout 112 and an attachment structure 113 similar to structure 55 of the same type described for each end guide tool 9.

[0050] The attachment structure 113 (see especially Figs. 9 to 11) includes a body 114 with an upperwardly extending, projection, flange or hook member 115 that follows the inner curvature of the guide tool leg 93. The body 114 extends radially inward and is sized and shaped to mate with and set within the bone screw head receiver 78. The bone screw receiver 78 is sufficiently wide to simultaneously receive both the body 114 and hook member 115 in a radially inward direction, as is shown in the view in Fig. 10. The attachment structure 113 is then set by axially raising the guide tool 10 relative to the bone screw 6 so at least part of the hook member 115 is located in the recess 80 which secures the guide tool 10 (likewise guide tool 9) to a respective bone screw 6, as seen in Fig. 11. This locks the guide tool 10 to a

respective bone screw 6 and prevents outward splaying of the leg 93. This is a snap-on type installation or assembly as seen in Fig. 7 where the leg 93 splays outward during initial placement of the guide tool 10 over the bone screw 6 and then returns to an unsplayed position when the attachment structure 113 seats in the receiver 78, as shown in Fig. 10. Alternatively, the guide tool 10 can be rotated approximately 90° about its axis A prior to joining with a respective bone screw 6, the attachment structure 113 lowered through the opening between the bone screw arms 74 and 75 and aligned with the bone screw receiver 78, after which the guide tool 10 is rotated back to the first position shown in Fig. 11 in a twist on type assembly. In some instances the guide tool 10 is rotated somewhat more or less than ninety degrees to make the necessary alignment for removal which depends on the specific construction of the parts.

[0051] Enclosure 52 closes between the spaced bone screw arms 74 and 75 to secure the rod 4 in the channel 67. The closure top 52 can be any of many different plug type closures. Preferably the closure top 52 has a cylindrical body 123 that has a helically wound mating guide and advancement structure 125. The guide and advance at structure 125 can be of any type, including V-type threads, buttress threads, reverse angle threads, or square threads. Preferably the guide and advancement structure 125 is a helically wound flange form that

interlocks with a reciprocal flange form as part of the second guide and advancement structure 76 on the interior of the bone screw arms 74 and 75. A suitable locking guide and advancement structure of this type is disclosed in U.S. Patent \_\_\_\_\_ from Serial No. 10/236,123 which is incorporated herein by reference. The helical wound guide 50 and advancement structure in the bottom 39 of each of the guide tools 9 and 10 is sized and shaped to receive the mating guide and advancement structure 125 of the closure top 52 and align with the second guide and advancement structure 76 of the bone screw 6 to form a generally continuous helically wound pathway, but does not require locking between the closure top 52 and the tools 9 and 10, even when a locking flange form is utilized on the closure top 52. The illustrated structure 125 has a square form or a square thread type shape. The guide 50 allows the closure top 52 to be rotated and the surgeon to develop mechanical advantage to urge or drive the rod 4, while still outside the bone screw head 6, toward and into the bone screw head 66. This is especially helpful where the rod 4 is bent relative to the location of the vertebra 18 to which the rod 4 is to attach and is not easily placed in the bone screw head 66 without force and the mechanical advantage provided by the guide 50. In particular, the first guide and advancement structure 109 on each tool 9 and 10 is located and positioned to align with the second guide and

advancement structure 76 on the insides of the bone screw arms 74 and 75, as seen in Figs. 17 and 18 and pass the closure top 52 therebetween while allowing the closure top 52 to continue to rotate and to continuously apply force to the rod 4, so as to seat the rod 4 in the bone screw head 66.

[0052] Each closure top 52 also preferably includes a break off head 127 that breaks from the body 123 in a break off region 128 upon the application of a preselected torque, such as 95 inch-pounds. The break off head preferably has a hexagonal cross section faceted exterior 129 that is adapted to mate with a similarly shaped socket of a closure driving or installation tool 145, described below. It is foreseen that different driving heads or other methods of driving the closure top 52 can be utilize with certain embodiments of the invention.

[0053] Additional tools are utilized to assemble the implant. In particular, Fig. 16 illustrates a rod pusher 136 on the left. The pusher 136 has an elongate shaft or rod 138 that is preferably received in and passes through the interior of the guides 9 and 10, such as the channel 90 of the guide tool 10. The pusher 136 also has a tip 139 for engaging and urging the rod 4 downward, where there is minor resistance, and a handle 141. It is foreseen that a pusher or gripper of the type that operates outside the guide tools 9 and 10 can be

utilized, but is not preferred as such would normally require greater penetration of the skin 14 and more invasion of the patient.

[0054] Shown in Fig. 16 on the left and in Fig. 17 is the closure installation tool 145. The tool 145 has an elongate rod or shaft 147 adapted to be received in and pass axially through any of the channels of the guides 9 and 10 and a handle 149. The lower end of the rod 147 terminates in a socket 148 that is adapted to receive the closure break off head 127, as shown in Fig. 17.

[0055] Another tool used in implanting a rod 4 is an antitorque tool 153 which is seen in Figs. 20 to 22. The antitorque tool 153 is preferably used with the closure installation tool 145 to torque and set the closure top 52, so it is snug against the rod 4, and thereafter break away the break off head 127 in the manner shown in Fig. 22. The antitorque tool 153 includes a tubular hollow shaft 155 that is sized and shaped to be slidably received over the guide 9 and 10. The antitorque tool 153 has a lower end 157 that has a pair of diametrically spaced bridges 158. Each of the bridges 158 is sized and shaped to fit over the rod 4, as seen in Fig. 21. When in place, as seen in Fig. 21, the antitorque tool 153 allows a surgeon to counter torque applied by the installation tool 145, when applying torque to and breaking away the break off head 127. The antitorque tool 153 also has an upper handle 16 with an opening

through which the installation tool 145 passes in the manner suggested by the dashed lines in Fig. 20.

[0056] In use, the previously described tools are utilized to attach one or more rods 4 to the human spinal column 17.

[0057] The procedure is begun by forming a relatively small incision, such as incision 165 in the skin 14 for each bone screw 6 to be used. The incisions 165 are stretched into a round shape with a circumference equal to or just slightly larger than the guide tools 9 and 10. The skin 14 is relatively flexible and allows the surgeon to move the incision 165 around relative to the spine 17 to manipulate the various tools and implants, as required. A drill (not shown) is utilized to form a guide bore (not shown) in a vertebra 18 under guidance of non invasive imaging techniques, which procedure is well known and established. A thin pin 166 is inserted in the guide bore. A bone screw 6 is selected in accordance with the size of the patient's vertebra 18 and the requirements of the spinal support needed. Bone screws 6 having a rotatable or poly axial head 66 are preferred for the procedure, as such allow relatively easy adjustment of the rod 4 in the tools 9 and 10 during placement and for movement of tools 9 and 10, as described below. The bone screw 6 is also cannulated so as to be receivable over and guided by the pin 166 toward the proper position in the associated vertebra 18.



[0058] Before placing the bone screw 6 in the vertebra 18, the bone screw 6 is preferably joined to an associated guide tool 9 or 10. This could be done after insertion of the bone screw 6, but it is preferred to assemble both before inserting the bone screw 6. With respect to the intermediate guide tool 10, the lower end of the guide tool 10 is splayed or expanded outwardly by forcing the bone screw head 66 between the legs 93 and 94, in the manner shown in Fig. 7 until the attachment structure 113 aligns with the receiver 78 and the former snaps into the later, as shown in Fig. 8. Axial upward movement of the guide tool 10 relative to the bone screw 6 then sets the attachment structure 113 in the recess 80 in the process that is illustrated between Figs. 10 and 11. Alternatively, the tool 10 can be axially rotated ninety degrees relative to the bone screw 6 and the attachment structure 113 aligned with the recess 80 and then rotated back. The placement of the guide tools 9 on the associated bone screws 6 normally follows the later twist on procedure, as the structure of the guide tools 9 allow less flexing because of the longer back wall 21. With tool 9, the attachment structure 55 is placed in a respective receiver 55.

[0059] A series of bone screws 6 are installed in each vertebra 18 to be attached to the rod 4 by use of a screwdriver or installation tool 135, see Fig. 12, that has a head, designed to grip the particular bone screw 6

used and which is also cannulated to receive the pin 166. For each bone screw 6, an associated guide tool 9 or 10 extends through the skin 14, as seen in Fig. 13. An end guide tool 9 is located at each end of the series of bone screws 6 and an intermediate guide tool 10 is located on each intermediate bone screw 6. The end guide tools 9 are turned or rotated so the channels 34 therein face one another and the intermediate guide tools 10 are aligned so slots 105 align with the channels 34.

[0060] The rod 4 is then inserted diagonally through one of the end skin incisions 165 in the manner shown in Fig. 13 so that a first rod end 42 passes through the slots 105 in any intermediate guide tools 10 and into the channel 34 of the opposed end guide tool 9. Back muscle tissue separates easily here to allow the upper insertion of the rod 4 and can be further separated by finger separation or cutting through one of the incisions 165, if required.

[0061] After initial insertion, the second end 42 of the rod 4 is positioned in the channel 34 of the end guide tool 9 that is located next to the insertion point of the rod 4, as is seen in Fig. 14.

[0062] Once the rod 4 is positioned in the guide tools 9 and 10, a pusher tool 136 of the type shown in Fig. 16 is utilized to push the rod 4 in each guide tool 9 or 10 toward the bone screw 6 associated with the guide tool 9 or 10 until the rod 4 is in approximately the position

seen in Fig. 15. During this time, the end guide tools 9 can be manipulated to help movement of the rod 4 therealong and can especially have the tops thereof splayed outwardly relative to each other, as seen in Fig. 15. Again, the flexibility of the skin 14 allows such manipulation. Once the rod 4 reaches the bottom 39 of the end guide tools 9, the rod ends 42 encounter the cut outs 45 on either side of the rod 4 and pass therethrough. The rod 4 is sized to extend a little beyond each end bone screw 6 to ensure full capture and reduce likelihood of dislodgement. Because the channels 34 are slightly inward of the full outer length of the rod 4, the channels 34 must be tilted outward somewhat as seen in Fig. 15 to allow the rod 4 to pass down the channels 34 or one end 42 must be driven downward before the other. When the rod 4 is at the bottom of the guide tools 9 and 10, such as seen in Fig. 19, the end guide tools 9 can be returned to a position that is appropriate for properly aligning the bone screw heads 6 relative to the rod 4 prior to tightening and torquing the closure tops 52. Because the rod 4 is normally bent and/or the vertebrae 18 do not align properly, the rod 4 must normally be biased into the bone screw heads 6. This is accomplished by using the closure installation tool 145 in the manner illustrated on the right hand side in Fig. 16 and in Fig. 17.

[0063] In particular, the tool 145 has a socket 148 that grips the break off head 127 of the closure top 52. The installation tool 145 with closure top 52 therein is placed in the elongate top to bottom channel associated with the guide tools 9 and 10 either by entry from the side such as into channel 25 through opening 26 in guide tool 9 or into channel 25 through the top end 38 of the guide tool 9. The closure top 52 is then driven under manual control of the surgeon by use of the installation tool 145 toward the rod 4. Near the bottom of the guide tools 9 and 10, such as near the bottom 39 of end guide tool 9, the closure top 52 engages the helical wound first guide and advancement structure 50 and the tool 145 and closure top 52 are rotated mate the closure top helical mating structure 125 with the first guide and advancement structure 50 so as to drive the closure top 52 downward against the rod 4 and to urge the rod 4 downward into the bone screw channel 67. At the bottom of the guide tool 9 or 10, the closure top mating structure 125 engages and begins to mate with the guide and advancement structure 76 on a respective bone screw 6 and continued rotation of the tool 145 drives the rod 4 downward and into engagement with the dome 71 of the bone screw shank 60, so as to snug against and frictionally lock the shank 60 in position relative to the bone screw head 66, see Fig. 18.

[0064] Once all of the closure tops 52 are in final seating position in respective bone screws 6 and the surgeon is satisfied with the position of all of the elements, such as is seen in Fig. 19, the antitorque tool 153 is mounted over each guide tool 9 or 10, as shown in Fig. 21 with the bridges 158 straddling the rod 4 to prevent rotation. The installation tool 145 is inserted in the associated guide tool 9 or 10 and engaged with the break off head 127. By cooperative use of the tools 145 and 153 a preselected torque is manually applied to the break off head 127 and it breaks from the closure top body 123 in the manner shown in Fig. 22 and is removed along with the antitorque tool 153.

[0065] The guide tools 9 and 10 are then each rotated ninety degrees to align the attachment structure, such as structures 55 and 113 with the opening between bone screw arms 74 and 75, as shown in Fig. 23, so that the recess 49 straddles the rod 4 to allow the attachment structure 55 or 113 to disengage from the receiver 78. The guide tool 9 or 10 is then pulled axially upward away from the bone screw 6 and from the incision 165 in the skin 14, after which the incision 165 is closed.

[0066] It is to be understood that while certain forms of the present invention have been illustrated and described herein, it is not to be limited to the specific forms or arrangement of parts described and shown.

C L A I M S

What is claimed and desired to be secured by Letters  
Patent is as follows:

1. A tool set for implanting a spinal rod in a patient;  
said tool set comprising:
  - a) a pair of end guide tools;
  - b) each of said end guide tool being adapted to  
attach at a lower end thereof to a respective  
spinal implant bone screw; and
  - c) each of said end guide tools including a  
longitudinal guide channel extending upwardly  
from said lower end thereof; each of said  
channels being sized and shaped to be adapted  
to receive opposite ends of the rod for  
operably guiding the rod ends toward respective  
bone screws.
  
2. The tool set according to Claim 1 wherein said tool  
set further includes:
  - a) at least one intermediate guide tool;
  - b) each of said intermediate guide tools including  
attachment structure adapted for attachment to  
a respective bone screw; and
  - c) each of said intermediate guide tools including  
a longitudinal pass through slot extending from

a bottom thereof upward and being adapted to receive therethrough and guide the rod to a bone screw attached to a respective intermediate guide tool.

3. The tool set according to Claim 1 wherein:
  - a) said longitudinal guide channel is part of an open pathway that extends from near a bottom of a respective end guide tool to a top thereof; said pathway opening radially outward along the entire length thereof.
  
4. The tool set according to Claim 3 wherein:
  - a) each said end guide tool has a cutout region between said longitudinal guide channel and said guide tool lower end; said cutout being open in the rear so as to define a pass through slot sized and shaped to be adapted to allow passage therethrough of one end of the rod after the rod has been guided to near a bone screw by said channel.
  
5. The tool set according to Claim 1 wherein:

- a) each of said end guide tools has a lower attachment structure adapted to removably attach to a bone screw; and
  - b) each of said end guide tool attachment structures including a curved hook member that is sized and shaped to be adapted to be received in a receiver on a bone screw when said hook member is aligned with the receiver and rotated axially.
6. The tool set according to Claim 2 wherein:
- a) each of said intermediate tool guide slots extends to an intermediate location along the respective intermediate guide tool and at the top thereof opens into a radially outward opening upper channel with said upper channel extending to the top of said intermediate guide tool.
7. The tool set according to Claim 1 wherein:
- a) each end guide tool includes a lower end recess along said channel that is sized and shaped to abut against and bridge a portion of the rod during removal of said end guide tool from a respective bone screw, so that said end guide tool can be rotated relative to a bone screw from an attachment configuration to a removal



configuration with said recess being received around the rod; said recess having a curvature that is sized and shaped to be substantially the same as the rod.

8. A vertebral support rod implantation kit adapted for use with a plurality of vertebra including:
  - a) a plurality of poly axial bone screws with each bone screw being adapted for implantation in one vertebra; each of said bone screws having a mating attachment structure;
  - b) an elongate rod sized and shaped to extend between a pair of end bone screws of said plurality of bone screws;
  - c) a pair of end guide tools;
  - d) each of said end guide tools including an end guide tool attachment structure at a lower end thereof that operably and removably connects with said bone screw mating attachment structure of a respective bone screw; and
  - e) each of said end guide tools including a longitudinal guide channel extending upwardly from near said lower end thereof; each of said channels being sized and shaped to slidingly receive opposite ends of the rod for operably guiding the rod ends toward respective bone screws.

9. The kit according to Claim 8 wherein said tool set further includes:
- a) at least one intermediate guide tool:
  - b) each of said intermediate guide tools including intermediate guide tool attachment structure that operably and removably connects with said mating attachment structure of a respective bone screw; and
  - c) each of said intermediate guide tools including a longitudinal pass through slot extending from the bottom thereof upward and operably receiving therethrough and guiding intermediate locations along the rod to a respective bone screw attached to the intermediate guide tool.
10. The kit according to Claim 9 wherein:
- a) said longitudinal guide channel extends from near a bottom of a respective end guide tool to a top thereof providing an open pathway from a top to the bottom of a respective end guide tool.

11. The kit set according to Claim 10 wherein:
- a) each of said guide tools has a cutout region between said longitudinal guide channel and said guide tool lower end; said cutout providing a pass through slot sized and shaped to receive one end of the rod after the rod has been guided to near a respective bone screw by said channel.
12. The kit according to Claim 8 wherein:
- a) each of said end guide tools has a lower attachment structure;
  - b) each bone screw includes a mating attachment structure; said mating attachment structure including a circumferentially extending slot and an upper recess accessible from said slot; and
  - c) said end guide tool attachment structure including a curved hook member that is sized and shaped to operably be received in said recess on a respective bone screw when said hook member is aligned with said recess and rotated axially.

13. The kit according to Claim 9 wherein:

- a) each of said intermediate tool guide slots extends to an intermediate location along the respective intermediate guide tool and at the top thereof directly opens into a radially outward opening upper channel with said upper channel extending to the top of said intermediate guide tool.

14. The kit according to Claim 8 wherein:

- a) each end guide tool includes a lower end recess on said channel that is sized and shaped to abut against and bridge a portion of the rod during removal of said end guide tool from a respective bone screw, so that said end guide tool can be rotated ninety degrees relative to a bone screw from an attachment configuration to a removal configuration with said recess being received around the rod; said recess being sized and shaped to have a curvature that is substantially the same as said rod.

15. A bone screw and rod seating assembly comprising:
- a) a bone screw having a shank for implanting in a bone and a head with a channel adapted to receive a rod;
  - b) said bone screw head including a first attachment structure thereon;
  - c) an elongate guide tool having a radially outward facing channel extending parallel to an axis thereof and upwardly from near a bottom of said guide tool; said channel sized and shaped to receive a first end of a rod and operably guide said rod first end to said bone screw head; said guide tool being sized to partially extend above a patient's skin so as to allow percutaneous manipulation of said guide tool by a surgeon; and
  - d) said guide tool bottom including a second attachment structure thereon; said first and second attachment structures being mateable to releaseably secure said guide tool to said bone screw head.

16. A bone screw and rod seating assembly comprising:
- a) a bone screw having a shank for implanting in a bone and a head with channel adapted to receive a rod;
  - b) said bone screw head including a first attachment structure thereon;
  - c) an elongate guide tool having a radially pass through slot extending upwardly from near a bottom thereof; said slot being sized and shaped to receive a rod therethrough and operably guide said rod to said bone screw head; said guide tool being sized to partially extend above a patient's skin so as to allow percutaneous manipulation of said guide tool by a surgeon; and
  - d) said guide tool bottom including a second attachment structure thereon; said first and second attachment structures being mateable to releaseably secure said guide tool to said bone screw head.

17. A method of percutaneously implanting a rod along a human spine by attaching the rod to individual vertebrae in a selected group of vertebrae comprising the steps of:
- a) forming an incision in a patient's skin generally above at least two of said selected vertebrae;
  - b) inserting a polyaxial bone screw through each incision and implanting the bone screw in a respective vertebra;
  - c) joining an end guide tool to each of a pair of end bone screws to be used in conjunction with a pair of vertebrae at opposite ends of said selected group of vertebrae wherein each of said end guide tools includes an elongate channel extending upward from near a bottom of a respective end guide tool that is sized and shaped to receive an end of said rod;
  - d) rotating said end guide tools such that said channels are facing each other;
  - e) inserting said rod through one of said incisions so that each of said rod ends engages a respective channel; and
  - f) urging said rod along said channels to a bottom of the end guide tools and into heads of respective bone screw.

18. The method according to Claim 17 including the steps of:
- a) providing an intermediate guide tool for each bone screw used with each vertebra of said selected group of said vertebrae between said end vertebrae wherein each said intermediate guide tool has an elongate slot extending upward from a bottom of the intermediate guide tool; and
  - b) inserting said rod through each of said slots when placing said rod in said channels such that said rod is guided by said slots to respective bone screws.
19. In a procedure for implanting a rod in a human spine by inserting bone screws into selected vertebrae and thereafter attaching the rod to the bone screws; said improvement comprising the steps of:
- a) providing an end guide tool for each bone screw at opposite ends of said selected vertebrae wherein each of said guide tools removably attaches to a respective bone screw and has an elongate channel that extends upward from near a bottom of the guide tool; said guide tool being sized and shaped to extend above the skin of the patient when the guide tool is attached



to a respective bone screw with the bone screw located in a respective vertebra;

- b) aligning the channels in facing relationship;
- c) placing opposite ends of said rod in respective channels; and
- d) urging said rod toward said bone screws utilizing said channels to guide the ends of said rod.

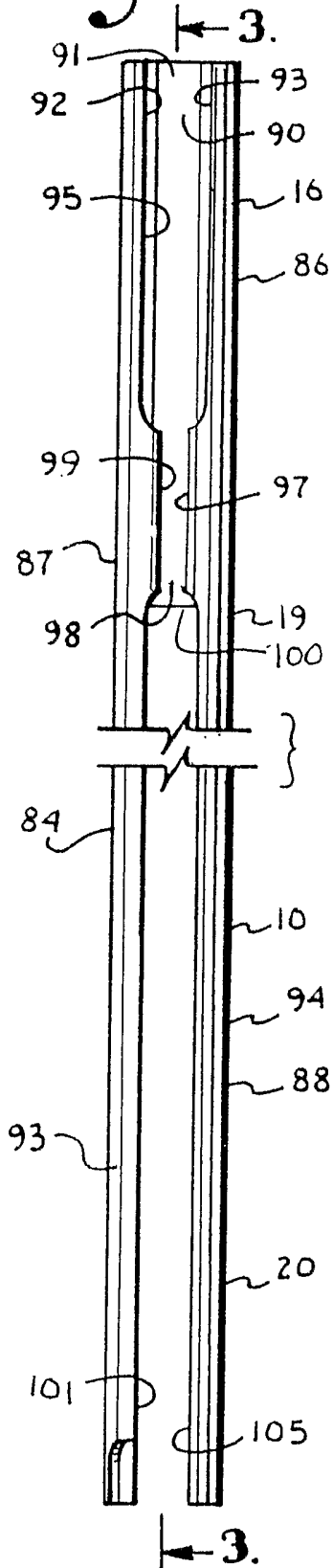
20. A method of percutaneously inserting a spinal rod into a pair of end bone screws comprising the steps of:

- a) providing a pair of end guide tools;
- b) inserting a said guide tool through a patient's skin and in communication with each respective end bone screw;
- c) inserting a rod and directing opposite ends of the rod to said channels; and
- d) guiding said rod ends in said channels to said bone screws.

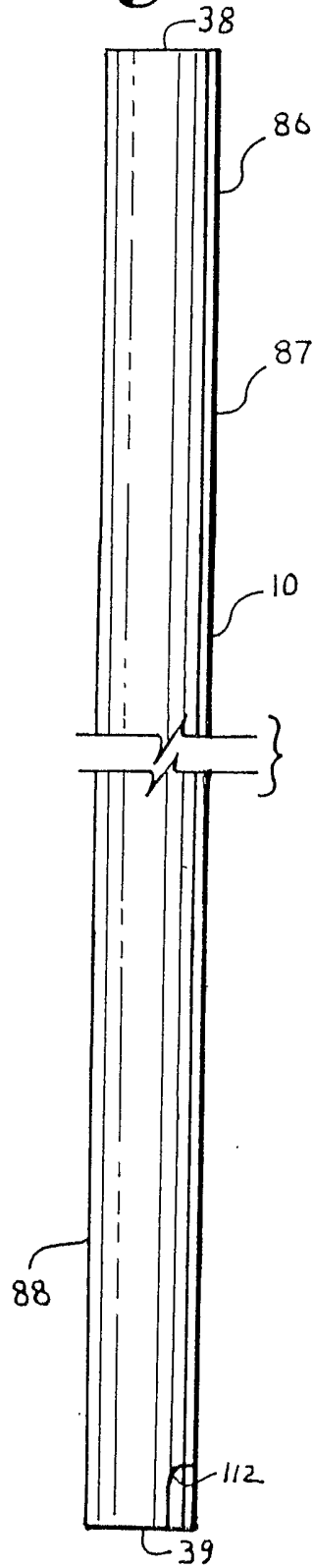
21. A method of implanting a spinal rod in a patient comprising the steps of:
- a) making an incision in a patient;
  - b) installing a bone screw in a vertebra of a patient through said incision;
  - c) attaching a guide tool to said bone screw wherein said guide tool includes an elongate channel;
  - d) inserting one end of said rod in said channel and thereafter urging said rod toward said bone screw under guidance of said channel;
  - e) securing said rod to said bone screw; and
  - f) removing said guide.
22. The method according to Claim 21 including the steps of:
- a) attaching said guide tool to said bone screw before inserting said bone screw in said vertebra;
  - b) prior to inserting said rod, inserting a driver through said guide tool and using said driver to install said bone screw in said vertebra; and
  - c) thereafter removing said driver from said guide tool.

23. In a guide tool for implanting a spinal rod in a bone screw the improvement comprising:
- a) a lower elongate channel sized and shaped to be operably located beneath a patient's skin during use and adapted to guide a rod to a bone screw connected to said guide tool; and
  - b) an outwardly open upper channel that is sized and shaped to side load so as to receive a closure top for the bone screw and being operably located above the patient's skin during use; said upper channel being connected with said lower channel so as to form a pass-through passageway to allow said closure top into said lower channel of said guide tool.

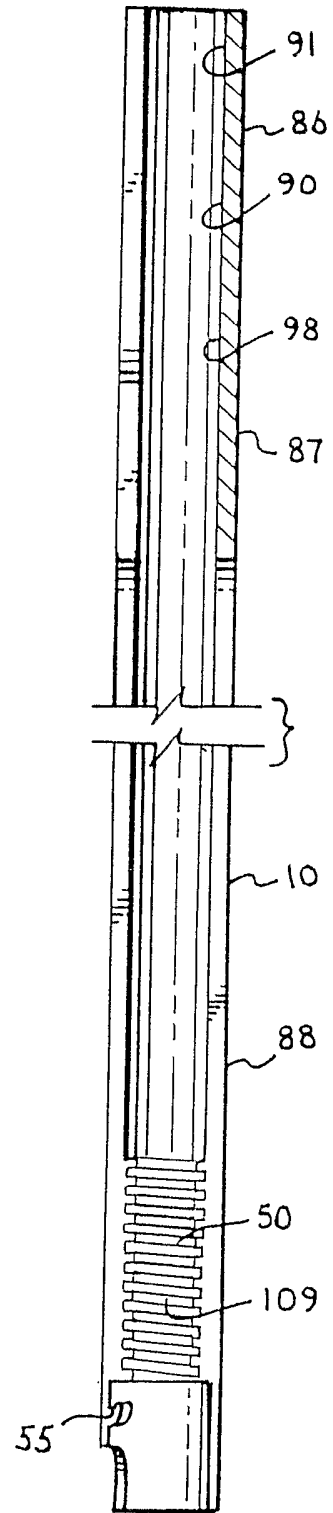
**Fig. 1.**



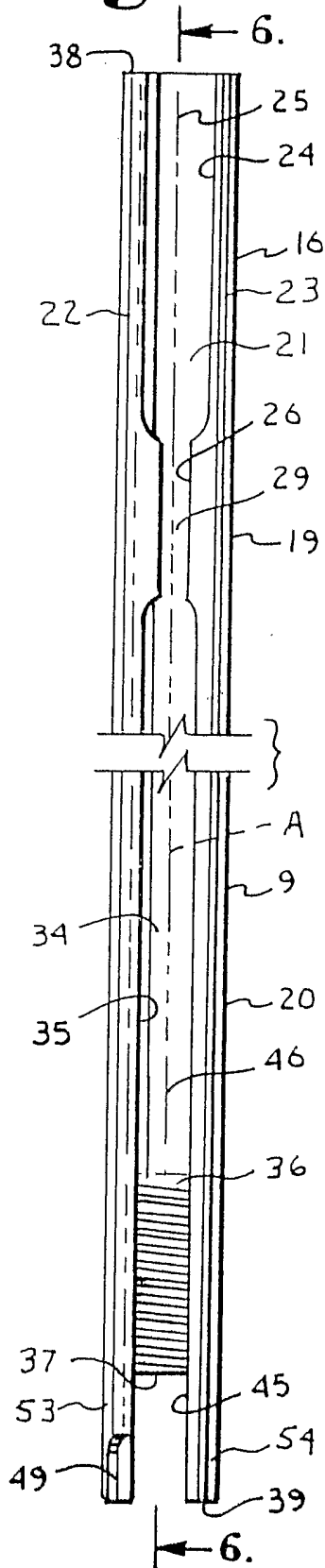
**Fig. 2.**



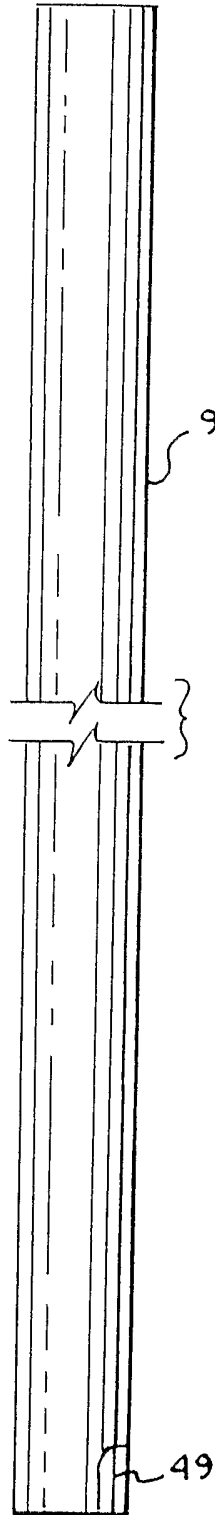
**Fig. 3.**



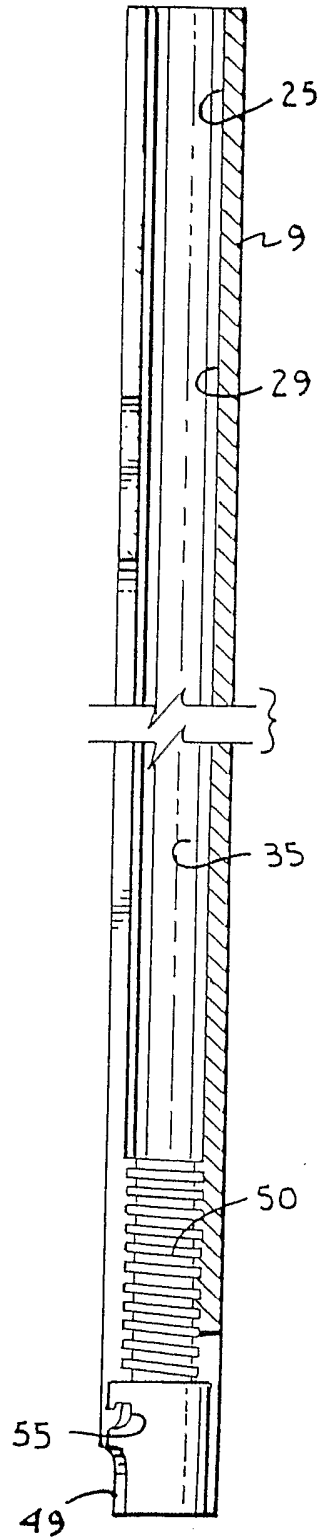
**Fig. 4.**

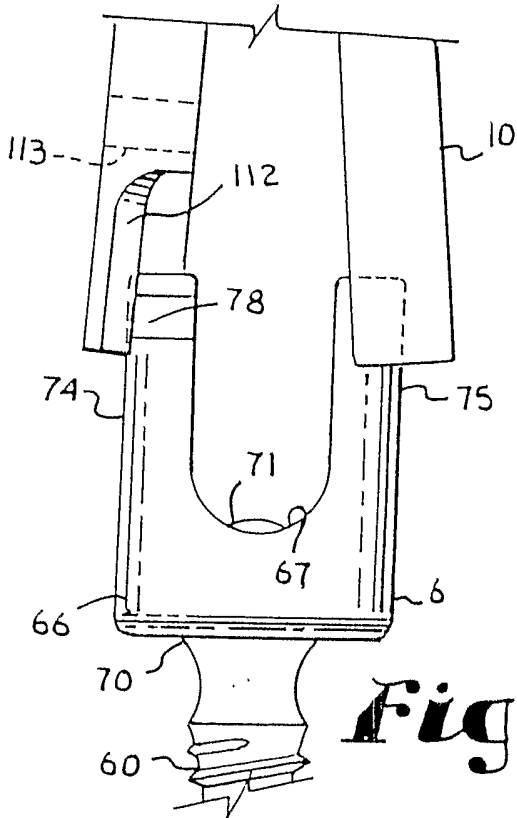


**Fig. 5.**

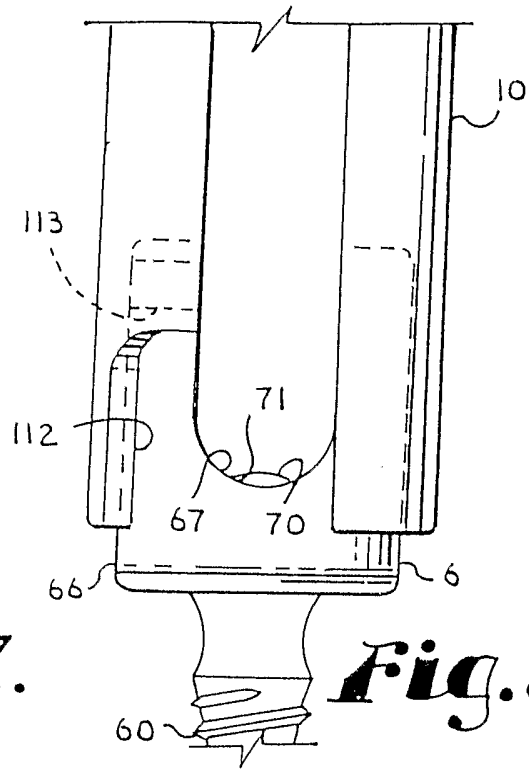


**Fig. 6.**





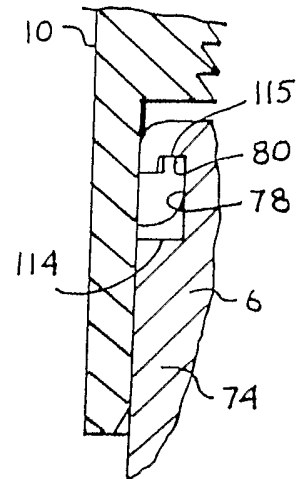
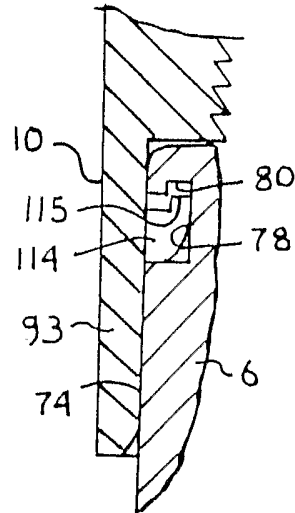
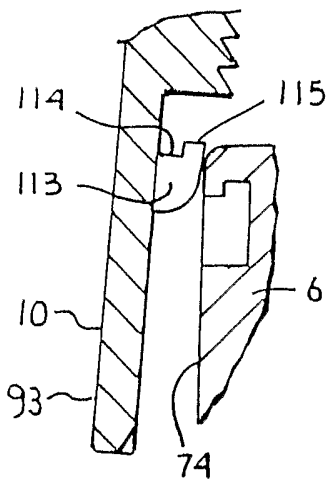
**Fig. 7.**



**Fig. 8.**

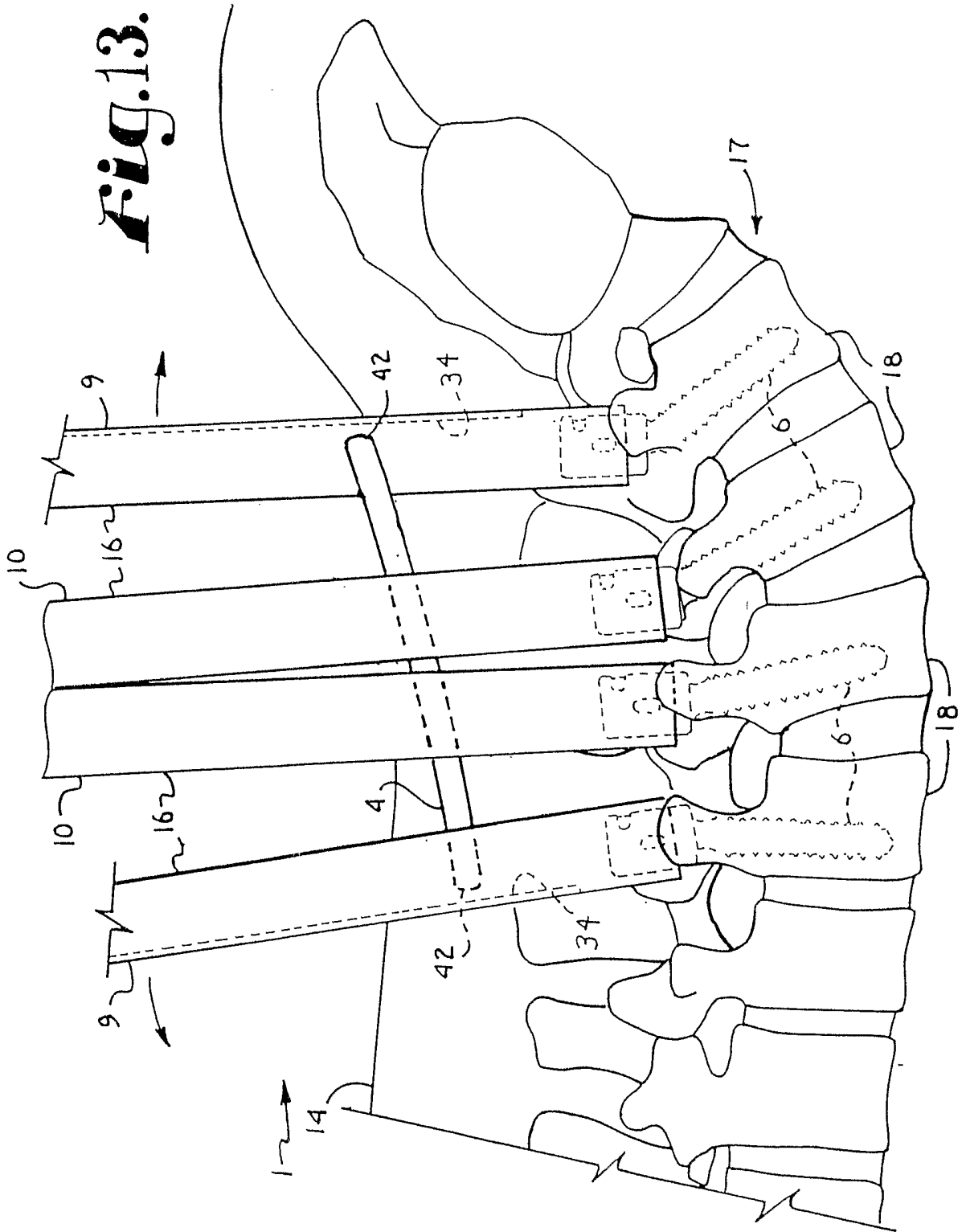
**Fig. 9.**

**Fig. 10. Fig. 11.**

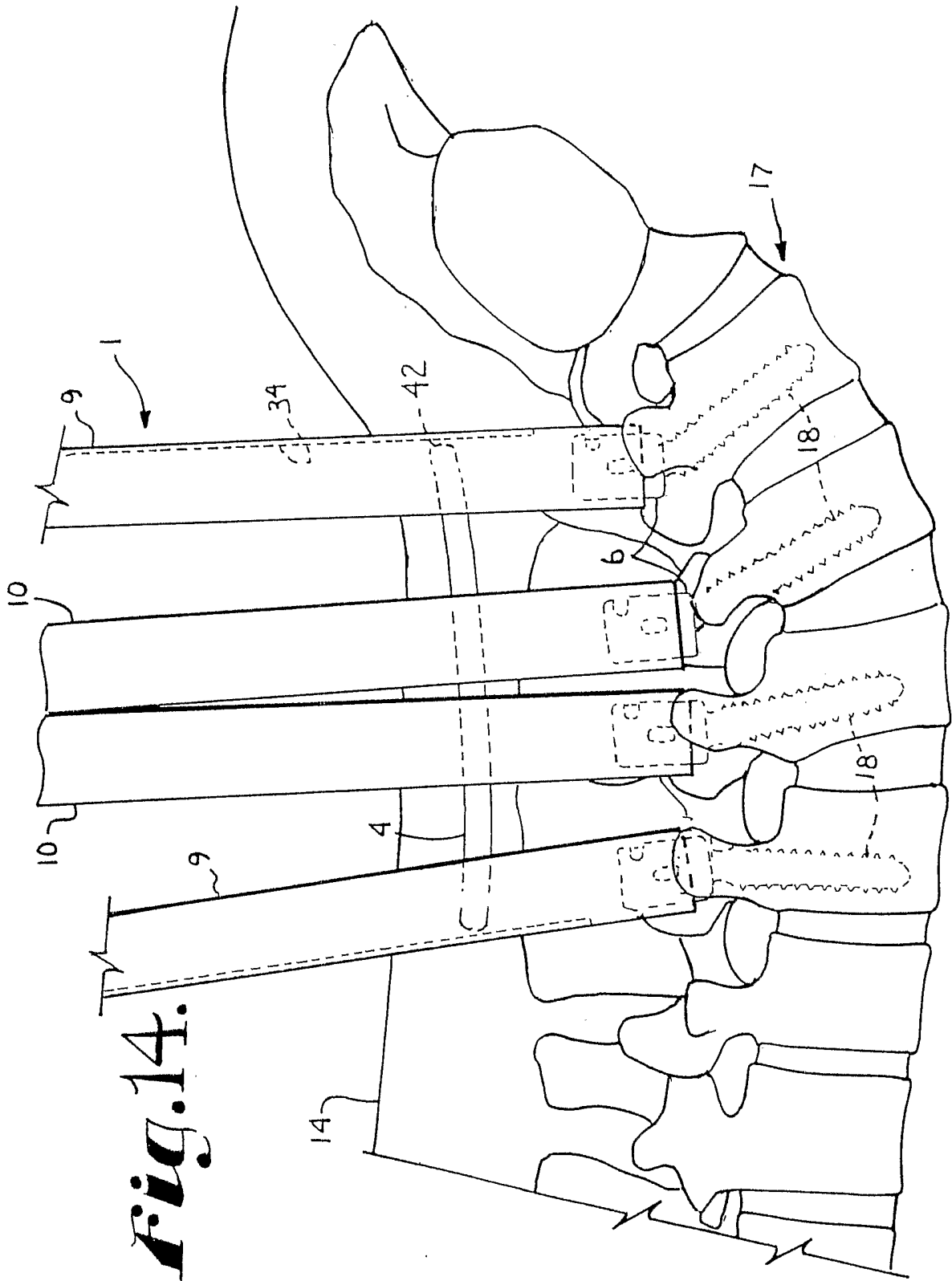




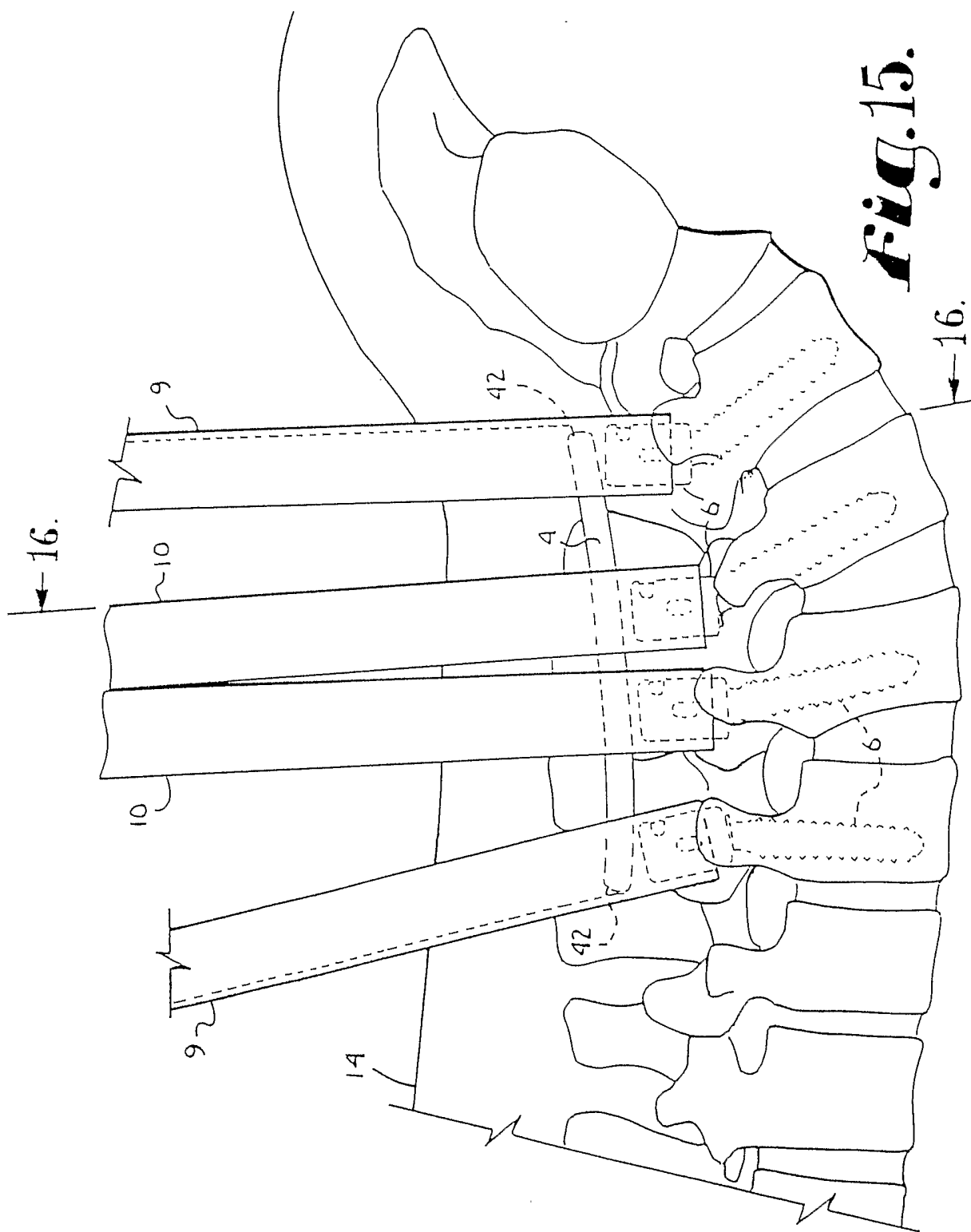
**FIG. 13.**



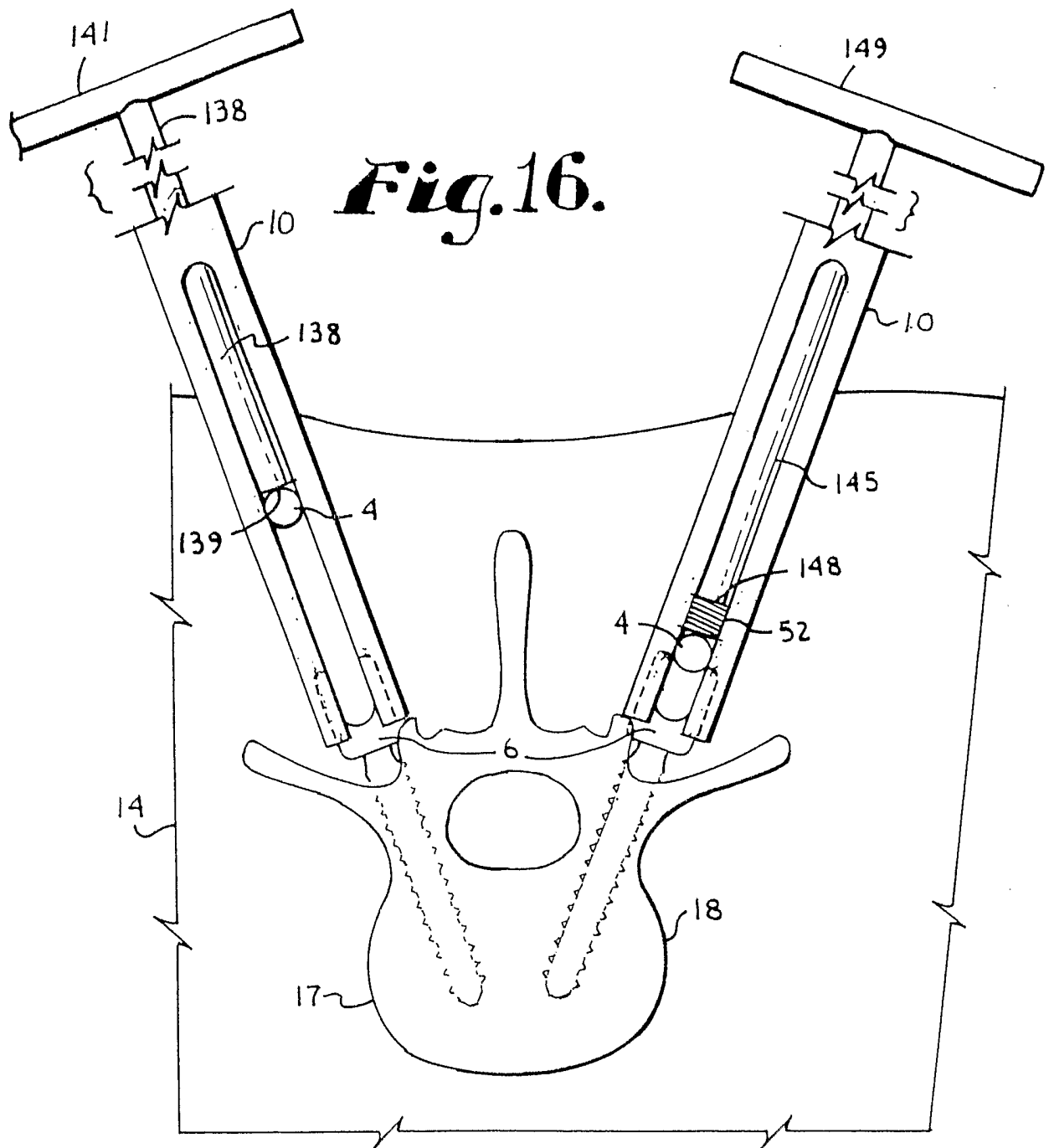




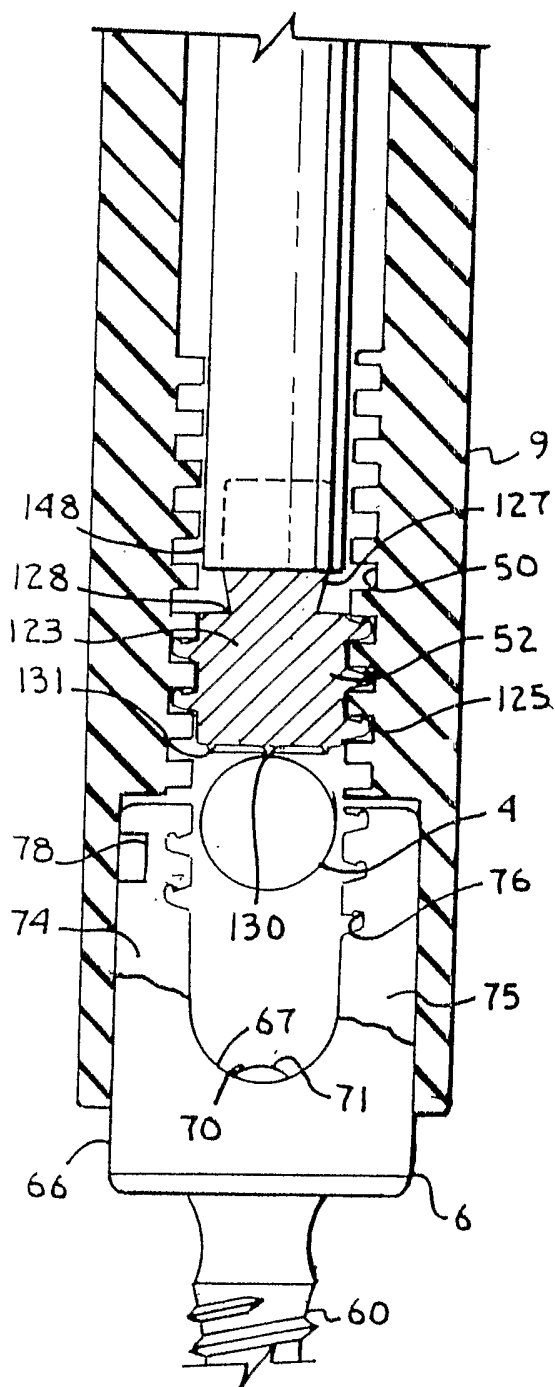
**Fig. 14.**



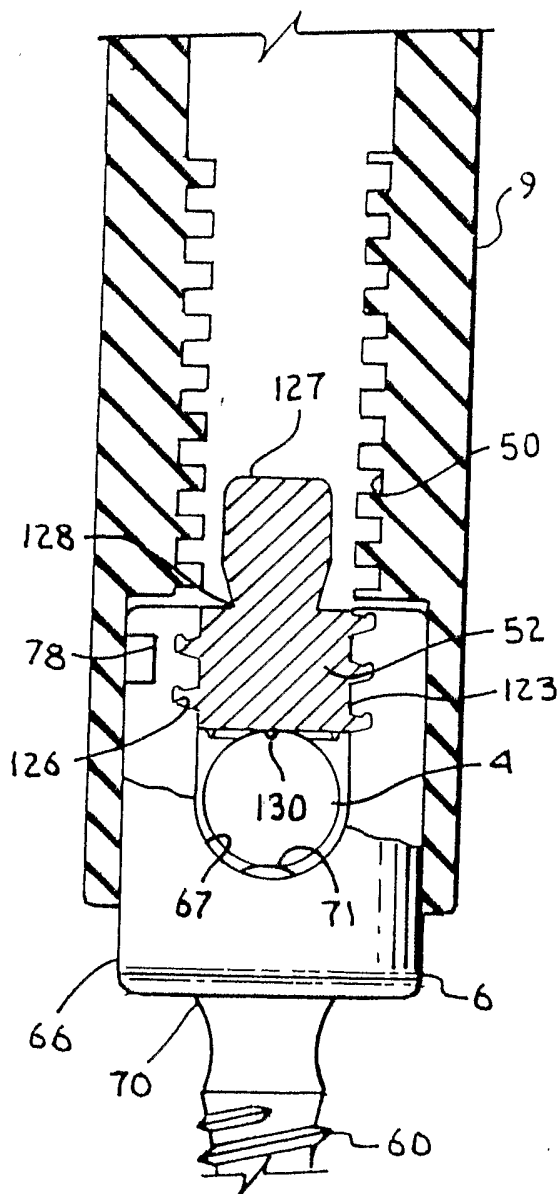
**FIG. 15.**

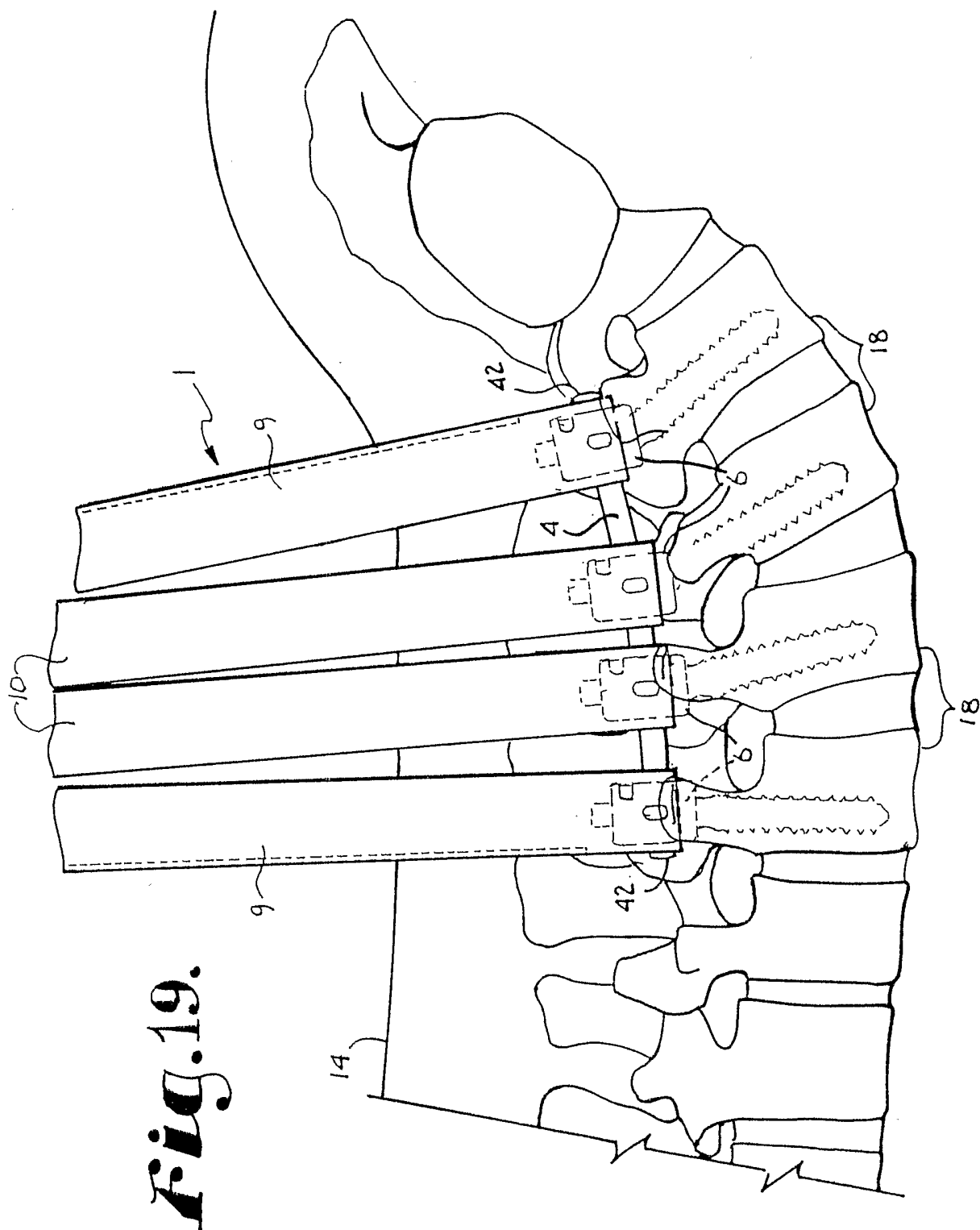


**Fig. 17.**



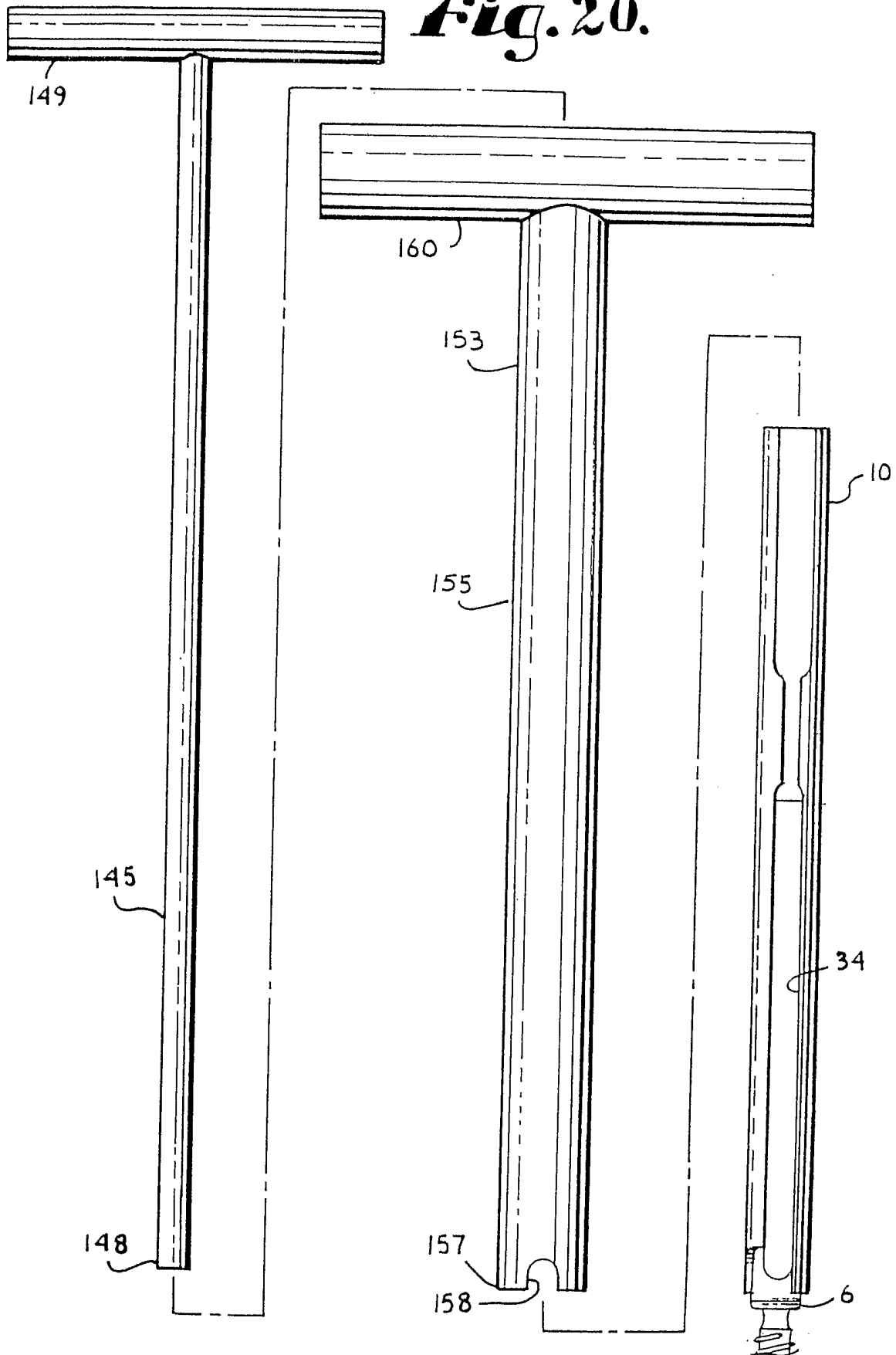
**Fig. 18.**



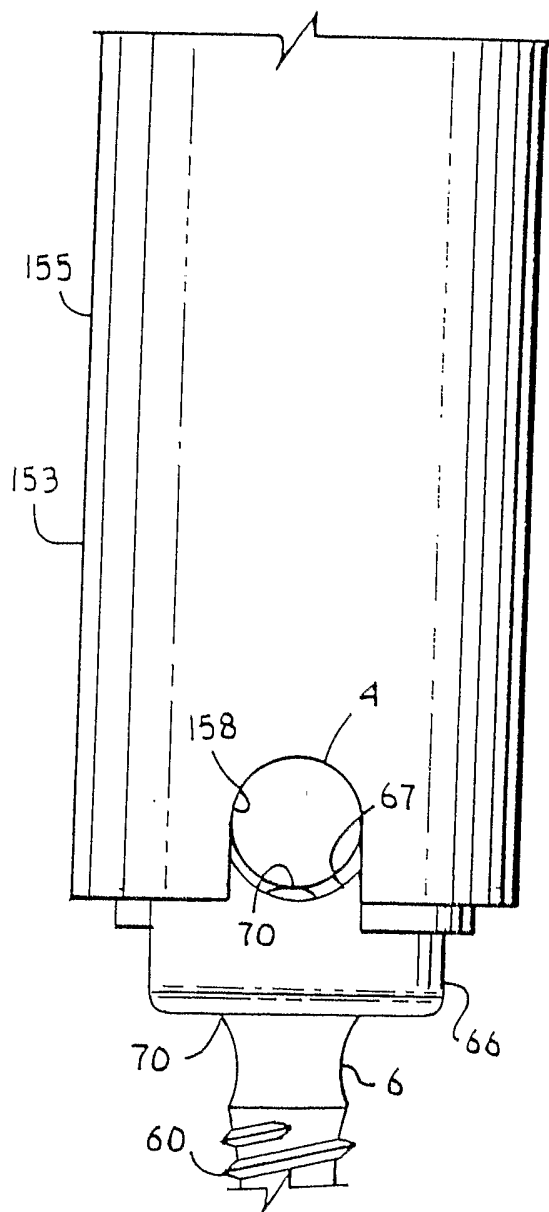


**Fig. 19.**

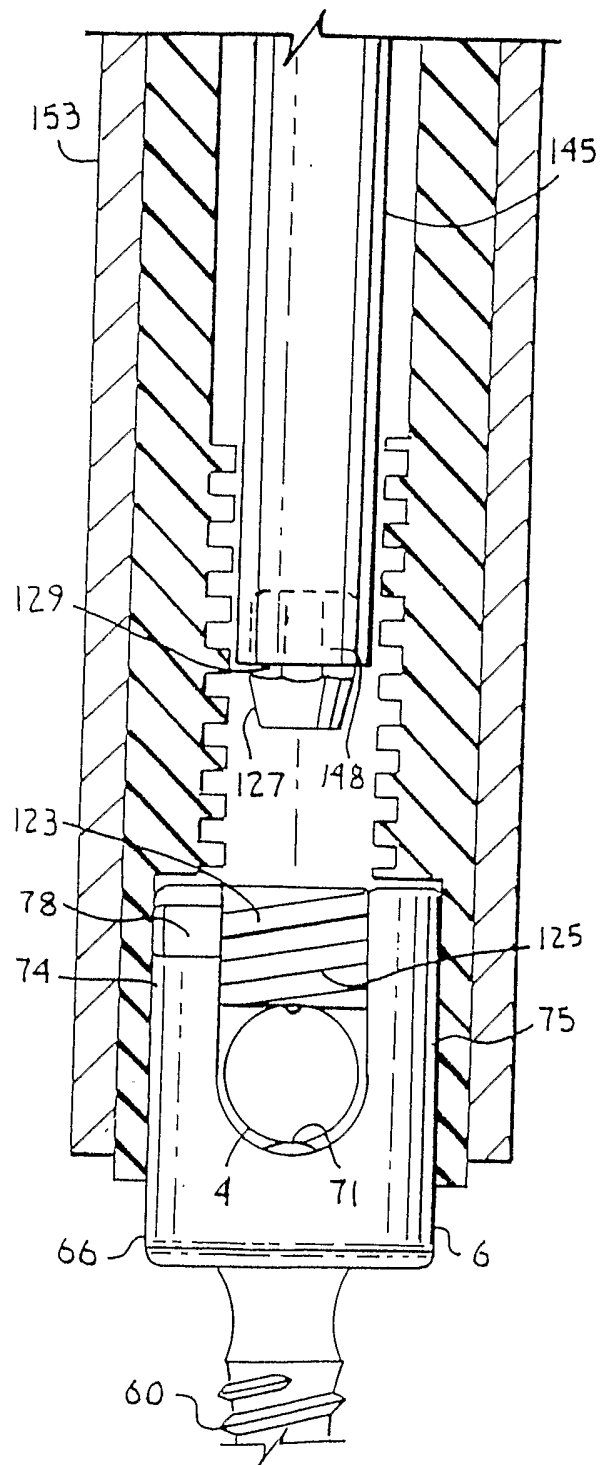
**Fig. 20.**

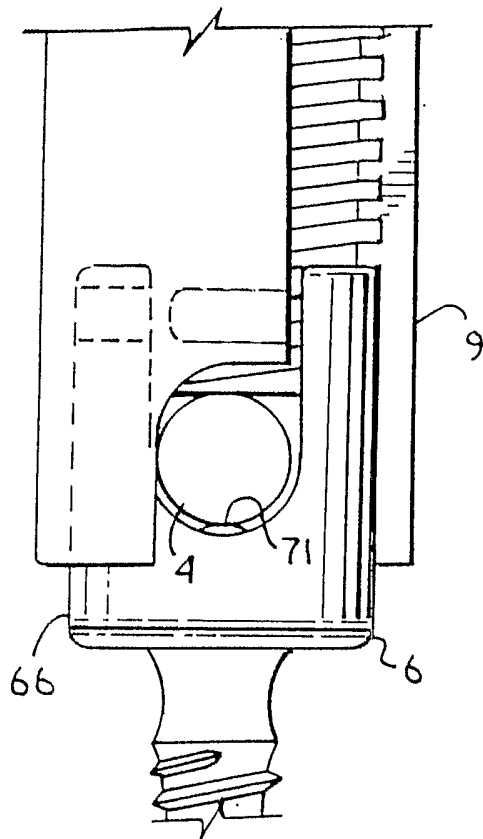


**Fig. 21.**

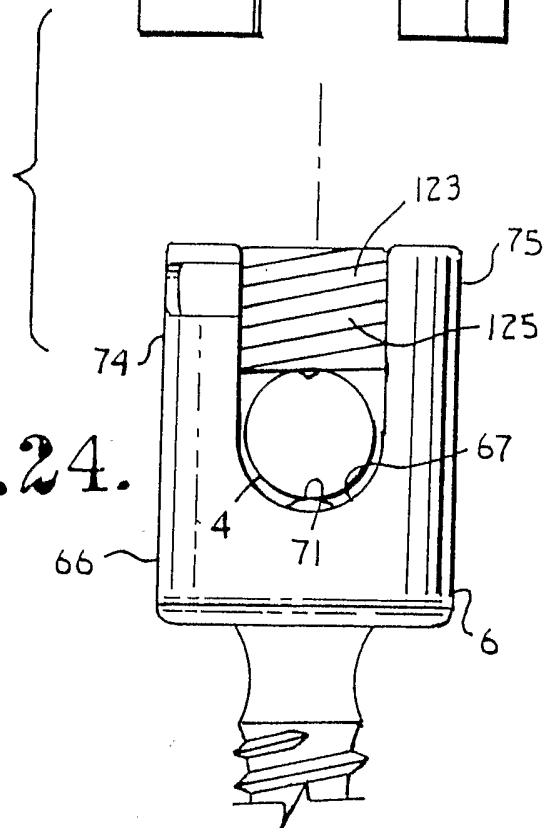
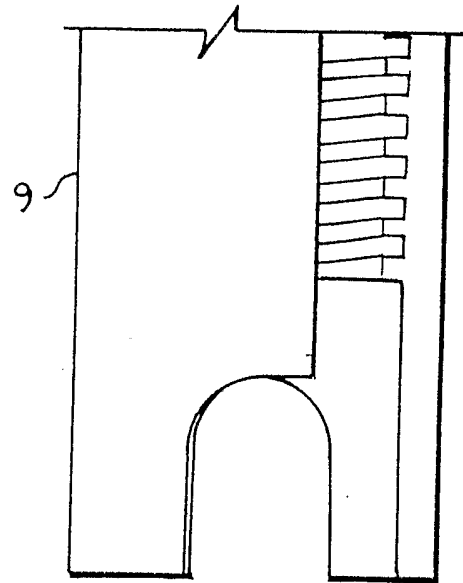


**Fig. 22.**





**Fig. 23.**



**Fig. 24.**



# INTERNATIONAL SEARCH REPORT

International application No.

PCT/US04/31860

**A. CLASSIFICATION OF SUBJECT MATTER**

IPC(7) : A61B 17/56

US CL : 606/61

According to International Patent Classification (IPC) or to both national classification and IPC

**B. FIELDS SEARCHED**

Minimum documentation searched (classification system followed by classification symbols)

U.S. : 606/61,104,60,72,73,77,99

Documentation searched other than minimum documentation to the extent that such documents are included in the fields searched

Electronic data base consulted during the international search (name of data base and, where practicable, search terms used)  
EAST

**C. DOCUMENTS CONSIDERED TO BE RELEVANT**

Category *	Citation of document, with indication, where appropriate, of the relevant passages	Relevant to claim No.
A,P	US 6,740,089 B2 (Haider) 25 May 2004 (25.05.2004) see entire document	1-23
A	US 5,720,751 A (Jackson) 24 February 1998 (24.02.1998) see entire document	1-23
A	US 4,409,968 A (Drummond) 18 October 1983 (18.10.1983) See entire document	1-23
A	US 6,440,133 B1 (Beale et al.) 27 August 2002 (27 .08.2002) See entire document	1-23

Further documents are listed in the continuation of Box C.  See patent family annex.

* Special categories of cited documents:		"T"	later document published after the international filing date or priority date and not in conflict with the application but cited to understand the principle or theory underlying the invention
"A"	document defining the general state of the art which is not considered to be of particular relevance	"X"	document of particular relevance; the claimed invention cannot be considered novel or cannot be considered to involve an inventive step when the document is taken alone
"E"	earlier application or patent published on or after the international filing date	"Y"	document of particular relevance; the claimed invention cannot be considered to involve an inventive step when the document is combined with one or more other such documents, such combination being obvious to a person skilled in the art
"L"	document which may throw doubts on priority claim(s) or which is cited to establish the publication date of another citation or other special reason (as specified)	"&"	document member of the same patent family
"O"	Document referring to an oral disclosure, use, exhibition or other means		
"P"	Document published prior to the international filing date but later than the priority date claimed		

Date of the actual completion of the international search 03 May 2005 (03.05.2005)	Date of mailing of the international search report <b>09 JUN 2005</b>
---	--

Name and mailing address of the ISA/US Mail Stop PCT, Attn: ISA/US Commissioner for Patents P.O. Box 1450 Alexandria, Virginia 22313-1450 Facsimile No. (703) 305-3230	Authorized officer Pedro Philogene <i>[Signature]</i> Telephone No. (571) 272-4716
---	--