

Jan. 20, 1970

R. C. LAGERSTROM

3,490,089

COMBINATION HANDLE AND SWITCH ACTUATOR

Filed Nov. 24, 1967

3 Sheets-Sheet 1

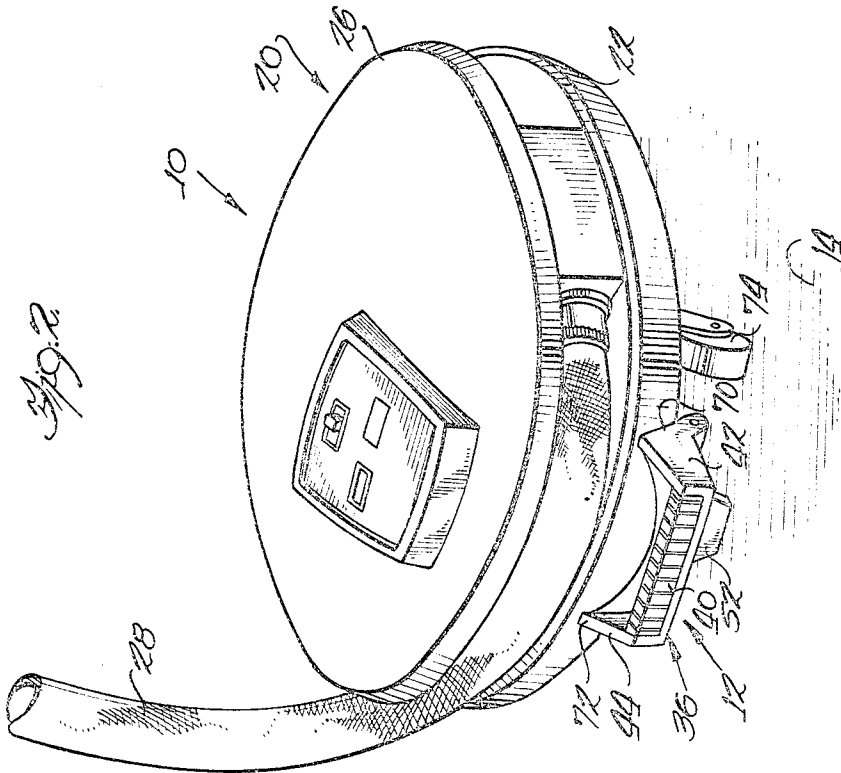

Fig. 2

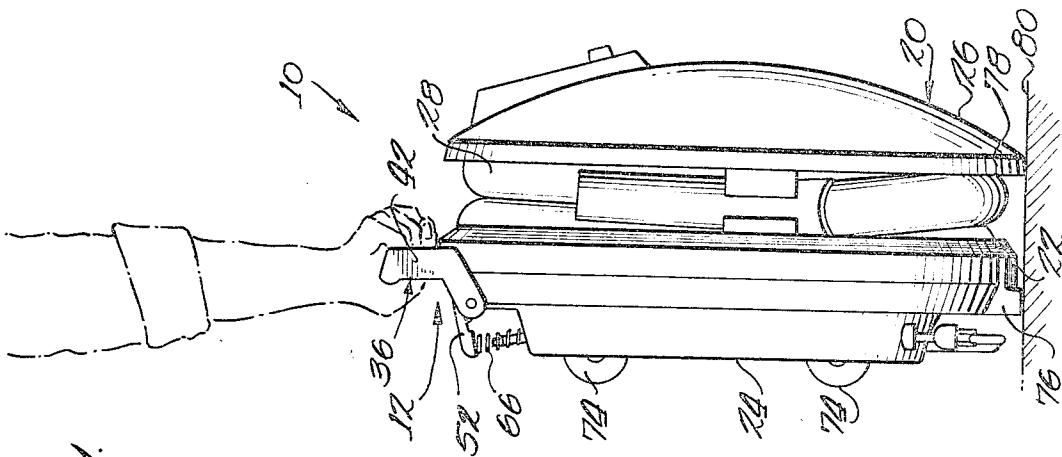

Fig. 1

Inventor
Robert C. Lagerstrom
By: Hibben, Rogers & Bicknell
Attys

Jan. 20, 1970

R. C. LAGERSTROM

3,490,089

COMBINATION HANDLE AND SWITCH ACTUATOR

Filed Nov. 24, 1967

3 Sheets-Sheet 2

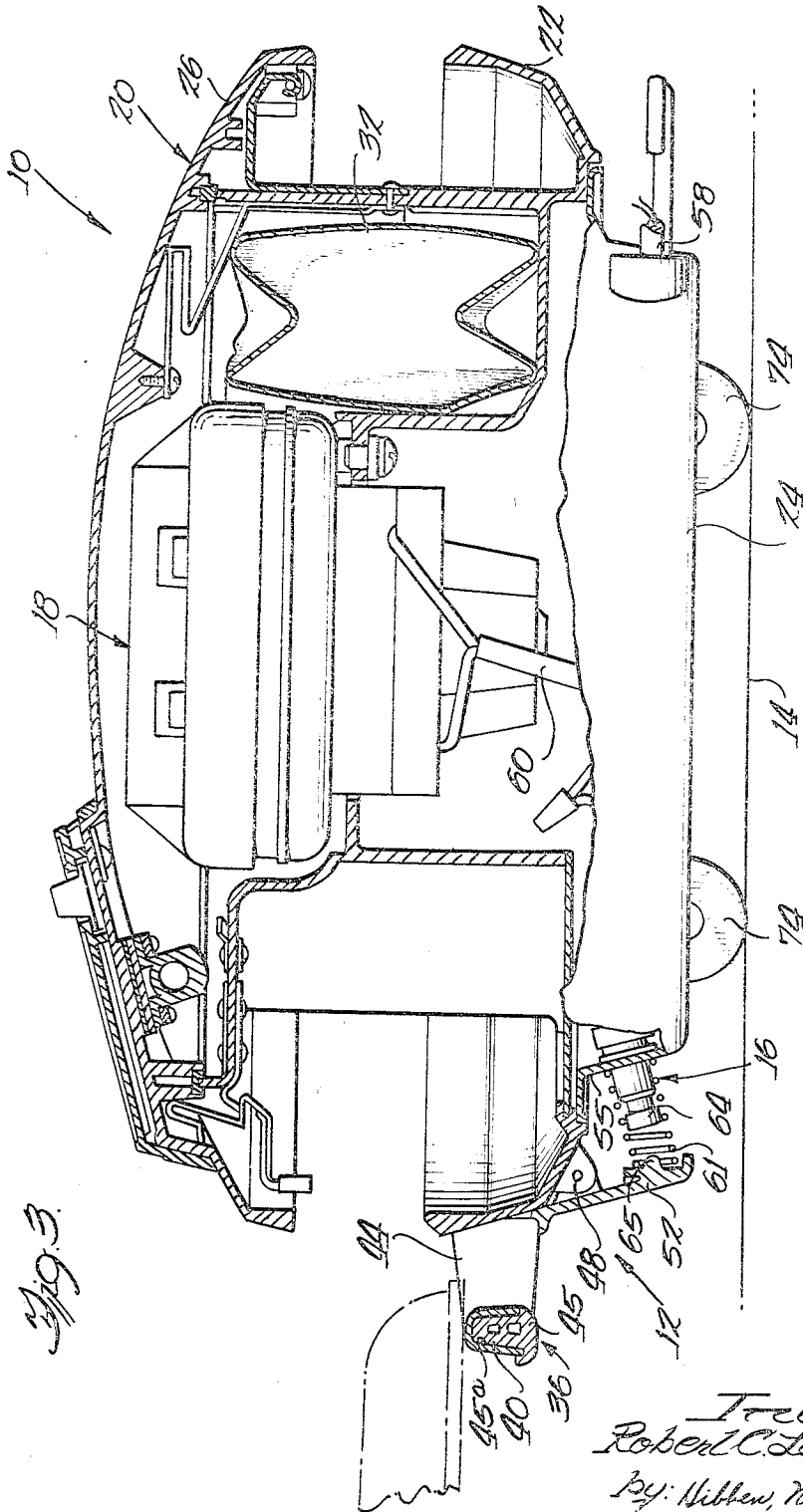

Fig. 3

Inventor
Robert C. Lagerstrom
By: Hibben, Noyes & Bicknell
Attys

Jan. 20, 1970

R. C. LAGERSTROM

3,490,089

COMBINATION HANDLE AND SWITCH ACTUATOR

Filed Nov. 24, 1967

3 Sheets-Sheet 3

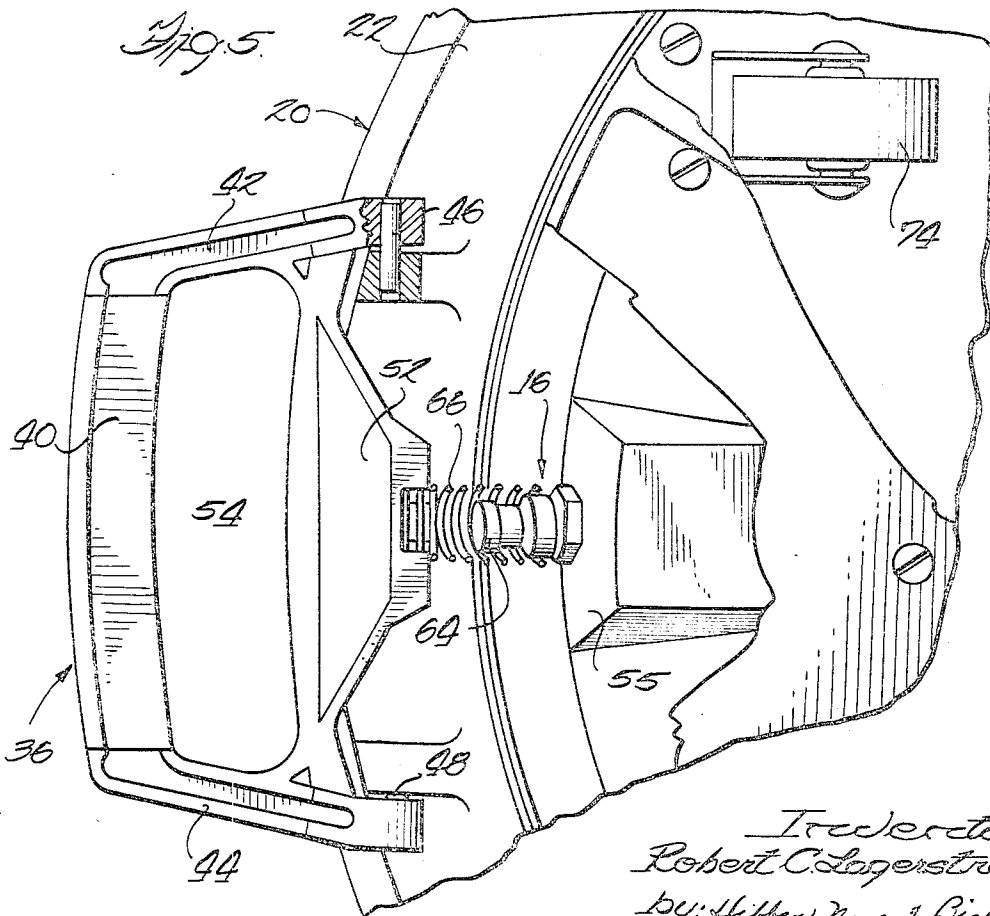
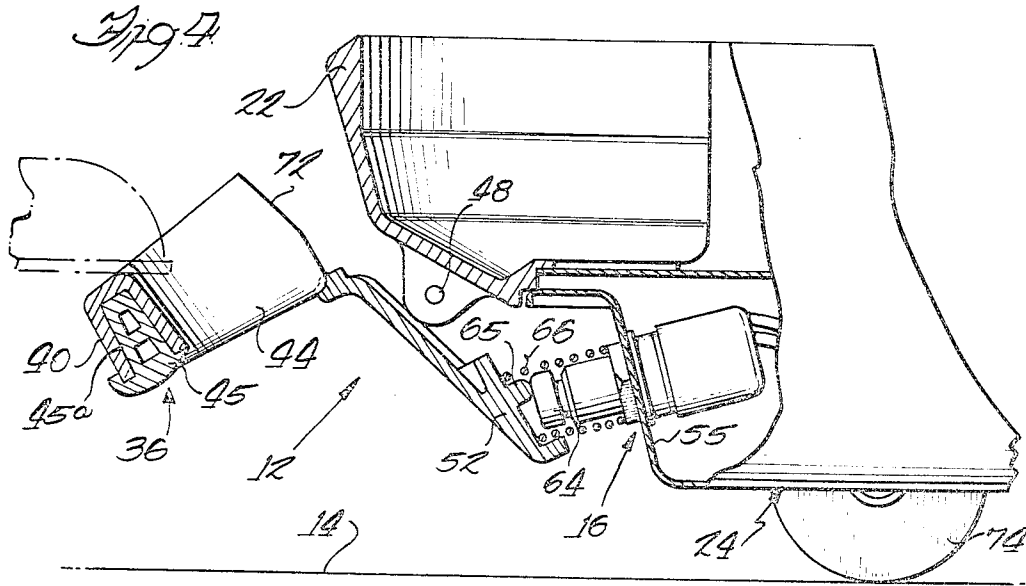

Inventor
Robert C. Lagerstrom
by: Helten, Noyes & Bicknell
Attys

1

2

3,490,089

COMBINATION HANDLE AND SWITCH ACTUATOR

Robert C. Lagerstrom, Normal, Ill., assignor to National Union Electric Corporation, Stamford, Conn., a corporation of Delaware

Filed Nov. 24, 1967, Ser. No. 685,532

Int. Cl. A47I 5/00

U.S. Cl. 15—327

5 Claims

ABSTRACT OF THE DISCLOSURE

This invention relates to a suction cleaner assembly having a carrying handle which is selectively movable to actuate a switch and thereby control the operation of a motor for the cleaner assembly.

Housewives and other users of vacuum or suction cleaner assemblies require that the cleaner assemblies be both inexpensive and easy to use. Therefore, it is an object of this invention to provide a suction cleaner assembly which is relatively low in cost and easy to use. Specifically, it is an object of this invention to provide a cleaner assembly having an inexpensive and readily accessible combination carrying handle and switch actuator.

Other objects and features of the invention will become more apparent upon a consideration of the following detailed description taken in connection with the accompanying drawings wherein:

FIG. 1 illustrates a cleaner assembly having a combination handle and switch actuator in accordance with the present invention, the cleaner assembly being shown in an upright carrying position or orientation;

FIG. 2 is a perspective view of the cleaner assembly of FIG. 1, the cleaner assembly being shown in operating position;

FIG. 3 is a sectional view of the cleaner assembly of FIG. 1, the combination handle and switch actuator being shown in a normal position;

FIG. 4 is an enlarged fragmentary sectional view illustrating the combination handle and switch actuator in an operated position pivoted downwardly from the normal position of FIG. 3 by a foot of an operator to actuate an on-off or motor control switch; and

FIG. 5 is an enlarged fragmentary bottom plan view further illustrating the structure of the combination handle and switch actuator.

A vacuum or suction cleaner assembly 10, forming an illustrative embodiment of the invention, includes a combination handle and switch actuator 12. The combination handle and switch actuator 12 is manually grasped, as shown in FIG. 1, to carry the cleaner assembly in an upright orientation or position to areas which are to be cleaned. After being transported to an area to be cleaned, the cleaner assembly 10 is placed on a support surface 14 in an operating position, as shown in FIGS. 2 and 3, with the combination handle and switch actuator 12 projecting laterally outwardly or sidewardly in a generally parallel relationship to a support surface 14. An operator then engages the combination handle and switch actuator 12 with his foot, as shown in FIGS. 3 and 4, and pivots the combination handle and switch actuator downwardly to the operated position of FIG. 4. This pivoting movement actuates an on-off or motor control switch 16 to start or energize a motor and fan assembly or suction unit 18. Of course, if the cleaner assembly 10 is used in an upright position for cleaning stairs or other areas, the combination handle and switch actuator 12 can be manually pivoted to the operated position to actuate the switch 16.

The cleaner assembly 10 includes a generally circular housing or casing 20 which is provided for supporting and enclosing the suction unit 18. The casing 20 (see FIG. 3) has a base section 22 on which the suction unit 18 is mounted, a base plate assembly 24 which is fixedly connected to the base section 22 and a cover section 26 which is pivotally connected to the base section 22. A hose or conduit 28 (see FIG. 2) is connected to the casing 20 for conducting air, entrained dirt and other foreign particles into a filter bag 32 (see FIG. 3) when the suction unit 18 is energized to draw air through the conduit 28 in a well known manner. The structure of the casing 20 and operation of the cleaner assembly is more fully described in application Ser. No. 683,435, filed on Nov. 13, 1967, by Harold W. Schaefer.

As will be evident especially from FIGS. 1 and 2, the cleaner casing 20 has a relatively squat or compact design in which the diameter of the circular casing is approximately twice as great as the axial height or thickness of the casing. As viewed in FIG. 1, the combination handle and switch actuator 12 is mounted off-center or to one side of a vertical or central plane through the center of the vertically disposed cleaner casing so that when the cleaner is in its usual horizontal operating position, as seen in FIG. 2, the handle and switch actuator 12 will be spaced a convenient distance above the surface 14 for easy engagement by an operator's foot.

The combination handle and switch actuator 12 includes a handle section 36 which projects laterally or radially outwardly from the edge of the circular casing 20 and beyond the peripheral extremity of the casing to enable the handle section 36 to be readily grasped to carry the cleaner assembly in the generally upright position of FIG. 1. This radially outwardly projecting relationship of the handle section 36 to the casing 20 enables the cleaner assembly 10 to be carried in the upright position with a major dimension or diameter of the casing 20 extending in a substantially vertical plane and a minor or axial dimension of the casing 20 extending laterally or sidewardly to minimize bumping or banging between the casing and a person carrying the cleaner assembly and to permit the cleaner to hang in a non-tiring position close to the body of the user. In the present instance, the handle section 36 includes an elongated grip or center section 40 (see FIG. 5) which is integrally formed with and extends between side sections 42 and 44 in a generally U-shaped configuration. The section 40 functions as a foot pedal when the cleaner assembly is in the operating position of FIGS. 2 and 3, and as a handle in the upright position of FIG. 1. An insert or pad 45 is provided in a channel 45a in the center section 40 to insure comfortable carrying of the cleaner assembly. The side sections 42 and 44 are pivotally connected by pins 46 and 48 to the base 22 of the casing 20. An actuator plate or lever 52 is integrally formed with and extends between the side sections 42 and 44 adjacent to the casing 20 in a substantially right-angular plane of the U-shaped relationship with the handle section 36. Thus, the center section 40, side sections 42 and 44 and actuator lever 52 form a unitary structure. The handle section 36 and actuator lever 52 define a hand receiving aperture 54 into which a hand of a person carrying the cleaner assembly 10 is inserted to grasp the elongated grip section 40 (see FIG. 1).

The combination handle and switch actuator 12 is pivotal at the pins 46 and 48, which are disposed intermediate the angularly related handle section 36 and actuator lever 52, to move the actuator lever 52 into engagement with the switch 16 to actuate the switch. The actuator lever 52 normally extends substantially parallel to a surface 55 of the base section 24 through which the switch 16 projects (FIG. 3). Actuation of the switch 16 completes a circuit to energize the suction unit 18 with electrical energy con-

ducted through a cord 58 and leads 60 to the suction unit. The switch 16 is of the well known "push-push" type and includes a reciprocable plunger 64 which is normally perpendicular to the actuator lever 52 and is engaged and pushed inwardly by a projection 65 at the inner face of the actuator lever 52 when the combination handle and switch actuator is pivoted for a first time from the normal position of FIG. 3 to the operated position of FIG. 4. The angular relation of the actuating lever 52 with respect to the handle section 36 and the location of the pivot axis defined by the pins 46-48 are such that the projection 65 initially contacts the head or end of the plunger 64 at approximately the center thereof as the handle section or foot pedal 36 is depressed. Thus, the maximum force on the plunger 64 is applied substantially axially even though at the end of the pivotal movement of the actuator lever 52 the projection 65 has moved to one side of the plunger head (FIG. 4). This movement of the combination handle and switch actuator 12 operates or actuates the switch 16 to complete the circuit for energizing the suction unit 18. When the combination handle and switch actuator 12 is rocked or pivoted inwardly about the pins 46 and 48 for a second time, the actuator lever 52 engages the plunger 64 to operate the switch 16 and interrupt the circuit for energizing the suction unit 18. A return spring 66 presses outwardly against the actuator lever 52 to urge the actuator lever toward the normal position shown in FIGS. 2 and 3 in which the lever 52 is spaced from the outer end of the plunger 64.

Although the switch plunger 64 is provided with the usual internal return spring (not shown), it is desirable to provide the auxiliary spring 66 to assist the switch spring in returning the actuator lever 52 to its normal position. Thus, a standard switch 16 can be used having an internal spring designed to permit easy actuation of the switch plunger 64 without excessive force, but the somewhat stronger auxiliary spring 66 insures a rapid positive return of the actuator lever 52. Also, when the cleaner is carried by the off-center handle 12 it tends to swing freely about the handle pivots 46-48, but the normal spaced relation between the actuator lever 52 and the plunger 64 permits limited swinging movement without engagement of the plunger 64 by the lever 52, and the spring 66 resists the swinging movement sufficiently to prevent undesired actuation of the switch plunger 64.

The side sections 42 and 44 of the handle section 36 have stop surfaces or shoulders 70 and 72 (see FIGS. 2 and 4) which engage the base section 22 to limit the pivoting movement of the combination handle and switch actuator 12 under the influence of the return spring 66. The shoulders 70 and 72 insure that the combination handle and switch actuator 12 extends in a radial relationship with the casing 20 and is easily engaged by an operator's foot when the cleaner assembly is in the operating position.

It is contemplated that the cleaner assembly 10 will be used primarily in the operating position shown in FIG. 3 with the handle section 36 projecting outwardly generally parallel to the support surface 14 to enable the section 40 to function as a foot pedal and to be readily engaged by an operator's foot. The cleaner assembly is movably supported in the operating position by wheels or casters 74 which engage the support surface 14 in a known manner. However, for certain cleaning operations, it is advantageous to use the cleaner assembly in an upright position as shown in FIG. 1. When the cleaner assembly 10 is used in an upright position, the operator actuates the switch 16 by grasping the grip section 40 of the handle section 36 and depressing the actuator lever 52 with his thumb. This movement pivots the actuator lever 52 into engagement with the plunger 64 and operates the switch 16. The cleaner assembly 10 is supported in the upright position of FIG. 1 by engagement of two legs or feet 76

(only one of which is shown) and a rim 78 of the cover section 26 with a support surface 80, the legs 76 being located diametrically opposite the combination handle and switch actuator 12.

In view of the foregoing description, it can be seen that I have provided a combination handle and switch actuator 12 which combines into a single integrally formed component the functions of a plurality of components of conventional cleaners. Thus, the combination handle and switch actuator reduces the cost of my cleaner assembly by reducing the number of required components. The handle 36 extends laterally or radially outwardly from the casing 20 to enable the handle 36 to be readily engaged by an operator's hand when carrying the cleaner assembly 10 and to enable the handle to be readily engaged by an operator's foot to actuate the switch 16 when the cleaner assembly 10 is in the operating position of FIG. 3. Therefore, the combination handle and switch actuator 12 also facilitates using the cleaner assembly 10. Although the combination handle and switch actuator 12 has been illustrated in association with a particular cleaner assembly, it will be apparent to those skilled in the art that the combination handle and switch actuator can be used with cleaner assemblies other than the specific one illustrated.

What is claimed is:

1. In a suction cleaner comprising a casing containing a motor-operated suction unit, a switch for said unit having a reciprocable operating member projecting from the casing, and support means on said casing for supporting said cleaner in normal operating position on a support surface, the improvement which comprises:

a combination handle and switch actuator structure, said structure including a generally U-shaped handle section and a switch actuating section extending rigidly in angular relationship with the plane of said U-shaped handle section;

pivot means on said structure intermediate said handle section and said switch actuating section, said pivot means being pivotally connected to a peripheral edge portion of said casing;

resilient means coacting between said casing and said switch actuating section for urging said structure to an outwardly pivoted position; and

stop means on said handle section engageable with said casing for limiting outward pivotal movement of said structure so that when the cleaner is supported on said support surface by said support means and said structure is in said outwardly pivoted position, said handle section extends in laterally projecting relation beyond the peripheral extremity of said casing and generally parallel to said support surface for convenient manipulation by a user's foot and said switch actuating section extends adjacent to but spaced from the outer end of said switch operating member.

2. The combination of claim 1 further characterized in that said handle section and said switch actuating section are disposed in a substantially right-angular relationship and said switch actuating section is generally perpendicular to said switch operating member when said structure is in said outwardly pivoted position.

3. The combination of claim 1 further characterized in that said casing has a generally circular configuration and said handle section extends generally radially from the casing when said structure is in said outwardly pivoted position.

4. The combination of claim 3 further characterized in that said casing has a diameter substantially greater than its axial dimension and said support means is adapted to support the casing on a horizontal support surface with the circular portion parallel to said surface, and said handle section is off-center with respect to a central plane through said casing so that when the cleaner is supported

5

by said support means and said structure is in said outwardly pivoted position, said handle section is parallel to and is spaced a convenient distance above said support surface for manipulation as a foot pedal.

5. The combination of claim 4 further characterized in that said casing is also provided with additional support means disposed at the peripheral edge thereof diametrically opposite said structure for supporting the cleaner in an upright position wherein the circular portion of the casing is generally perpendicular to said support surface and said handle section extends generally vertically when said structure is in said outwardly pivoted position.

6

References Cited

UNITED STATES PATENTS

2,287,474	6/1942	Hansson.	
2,369,519	2/1945	Barber.	
2,871,503	2/1959	Senne.	
2,918,692	12/1959	Martinec -----	15—327 XR
3,210,916	10/1965	Jepson -----	15—327 XR

FOREIGN PATENTS

647,455	12/1950	Great Britain.	
---------	---------	----------------	--

ROBERT W. MICHELL, Primary Examiner