



US 20040045552A1

(19) **United States**

(12) **Patent Application Publication**

Curti et al.

(10) **Pub. No.: US 2004/0045552 A1**

(43) **Pub. Date: Mar. 11, 2004**

(54) **NASAL CANNULA**

(76) Inventors: **James N. Curti**, Bakersfield, CA (US);
James Chua, Bakersfield, CA (US);
Peter W. Salter, Tehachapi, CA (US)

Correspondence Address:
DAVIS & BUJOLD, P.L.L.C.
FOURTH FLOOR
500 N. COMMERCIAL STREET
MANCHESTER, NH 03101-1151 (US)

(21) Appl. No.: **10/627,502**

(22) Filed: **Jul. 25, 2003**

Related U.S. Application Data

(60) Division of application No. 09/837,720, filed on Apr. 18, 2001, now Pat. No. 6,655,385, which is a division

of application No. 09/184,111, filed on Nov. 2, 1998, now Pat. No. 6,439,234, which is a continuation of application No. PCT/US98/05573, filed on Apr. 3, 1998.

(60) Provisional application No. 60/045,080, filed on Apr. 29, 1997.

Publication Classification

(51) **Int. Cl.⁷** **A61M 15/08**; A61M 16/00
(52) **U.S. Cl.** **128/207.18**; 128/200.26

(57) **ABSTRACT**

This invention is a nasal cannula (10) having a septum (15) therein, and two nares (13, 14) each having a hole (37, 35) therein to help prevent occlusion of the device from secretions. The cannula is connected to an oxygen source (G) and a CO2 monitor (A).

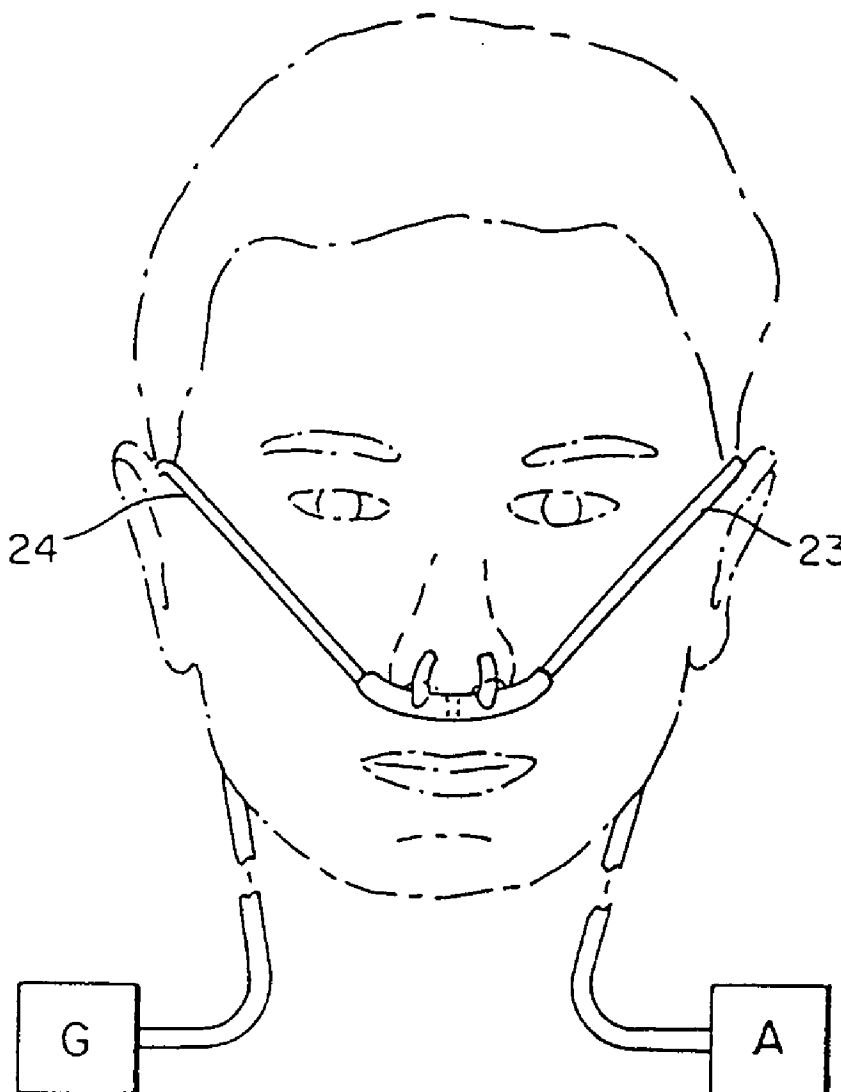

FIG. 1

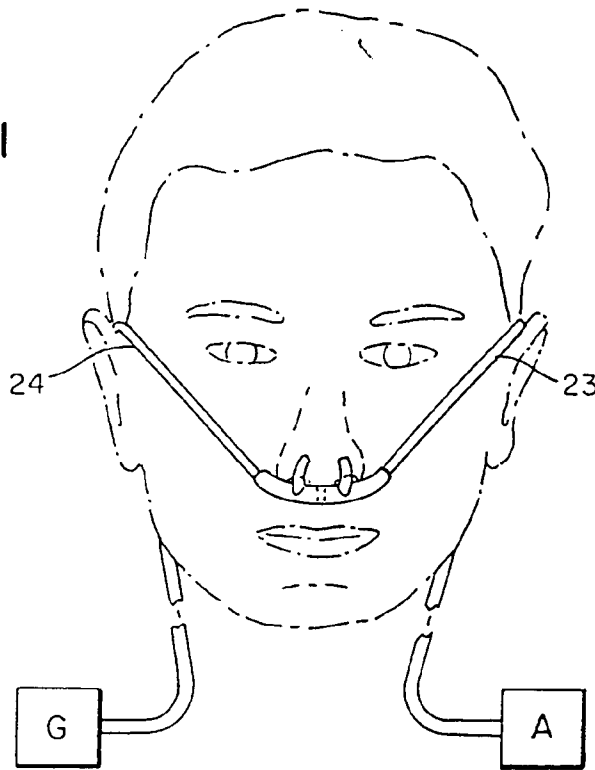

FIG. 3

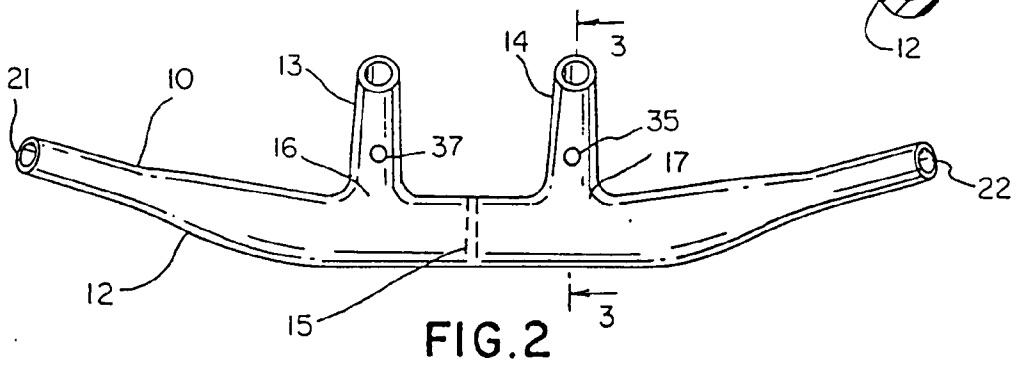
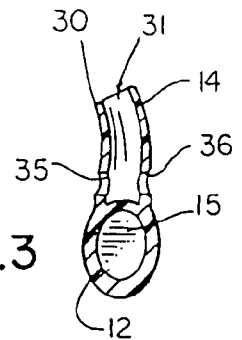

FIG. 2

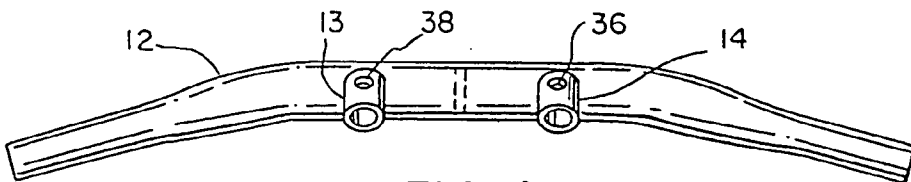

FIG. 4

NASAL CANNULA

BACKGROUND OF THE INVENTION

[0001] This application is a continuation of International Application PCT/US98/05573, filed Apr. 3, 1998.

[0002] The practice of measuring end-tidal carbon dioxide during the administration of anesthesia, particularly regional anesthesia, has grown markedly in the past several years. The reasons that anesthesiologists have embraced this technique are described more fully in U.S. Pat. No. 5,335,656 which is incorporated herein by reference in its entirety.

[0003] The preferred nasal cannula used in this procedure is a cannula which insufflates the patient with oxygen through one nare of a cannula and separately samples the exhaled gases by drawing the exhaled gas from the other nare into a conventional carbon dioxide analyzer. The cannula is preferably provided with an internal wall or system in the face piece to keep the conduits separate for insufflation and sampling, however, separate lines can be used or even multiple nares for insufflation and sampling, though the latter device substantially increases the risk of gases mixing which can distort the readings for end-tidal carbon dioxide. It is preferred that two nares only are employed and that each nare performs only one function, i.e., insufflation or sampling into or from separate nostrils. Likewise, insufflation has normally been continuous, however, it could advantageously be intermittent which would further improve the end-tidal carbon dioxide measurement by insuring that gases being sampled were representative of exhaled gases undiluted by the other gases being insufflated. Most preferably, the intermittent insufflation is accomplished by the apparatus and method described in U.S. Pat. No. 5,626,131 which is incorporated herein by reference in its entirety. Other so-called demand insufflation devices which begin insufflation upon the start of inhalation can also be employed.

[0004] Normal nasal cannulae are designed with the nares having a slight inward curvature as they extend upward from the face piece. This is anatomically desirable and important for imparting the proper direction of insufflating gas into the nasal cavities. When the patient is in the upright sitting position or ambulatory, this is the most satisfactory design configuration. Conversely, problems can be encountered if the patient is horizontal or prone and tends to accumulate secretions in the nasal cavities. It can be a particularly vexing problem if either the insufflation or sampling nare becomes occluded during the use of the cannula for sampling and monitoring end-tidal carbon dioxide during the administration of anesthesia.

OBJECTS OF THE INVENTION

[0005] It is therefore an object of the present invention to provide a nasal cannula structure for sampling carbon dioxide which reduces or eliminates the incidence of occlusion of the tip of the carbon dioxide sampling nare during the removal of carbon dioxide by the sampling line connected to a monitoring device and/or a source of suction or vacuum.

[0006] It is also an object of the present invention to provide a nasal cannula for insufflating a patient with oxygen while accurately monitoring end-tidal carbon dioxide, that will continue to function properly for its intended purpose when either or both nares become occluded for any reason.

[0007] It is a further object to accomplish the foregoing objects with a minimum risk of distorting the end-tidal carbon dioxide readings from the sampled exhalation gases during the administration of anesthesia.

BRIEF SUMMARY OF THE INVENTION

[0008] The foregoing objects and advantages are obtained by providing a nasal cannula structure that is adapted for insufflation and sampling, with additional holes or vents on the nares of the nasal cannula, preferably both anterior and posterior of one or both nares at a location proximate the entrance of the nasal passageways when the cannula is in use.

BRIEF DESCRIPTION OF THE DRAWINGS

[0009] FIG. 1 is a frontal view of a normally positioned nasal cannula on a patient (shown in phantom) connected to a gas source (G) and a gas analyzer (A).

[0010] FIG. 2 is a rear view of the cannulae face piece shown in FIG. 1.

[0011] FIG. 3 is a partial cross section of a nare of the nasal cannula taken along the lines and arrows 3-3 of FIG. 2.

[0012] FIG. 4 is a plan view of the nasal cannula of FIG. 2.

DETAILED DESCRIPTION OF THE ILLUSTRATED EMBODIMENT

[0013] The nasal cannula 10 of one embodiment of the present invention consists of a generally tubular face piece 12 having two nares 13 and 14 and a septum 15 disposed in the center of the face piece 12 between the openings 16 and 17, respectively, of the nares 13 and 14 (see FIGS. 2, 3 and 4). The openings 21 and 22 on the ends of the face piece 12 are affixed to separate tubes 23 and 24 as shown in FIG. 1, which are separately connected to a source of insufflating gas (G), such as oxygen, and a commercial carbon dioxide monitoring unit (shown as A) which, in turn, has or is connected to a vacuum pump or other means for drawing exhaled breath containing carbon dioxide into an instrument that is capable of measuring the concentration of the carbon dioxide in the sampled gas.

[0014] During use of the cannula for both insufflation and the monitoring of carbon dioxide concentration in the exhaled breath (depicted schematically in FIG. 1), the readings for end-tidal carbon dioxide can become distorted where there is undesirable mixing with room air or with excess insufflating gas. Likewise, carbon dioxide measuring devices which typically employ varying amounts of suction or vacuum to obtain the gas sample to be analyzed, can unduly dilute the sample or more seriously can draw the tip 30 of the sampling nare (representatively shown in FIG. 3) onto the adjacent surface of the tissue of the nasal passage and occlude the opening 31 thereby restricting or even preventing sampling of the exhaled gases for their carbon dioxide concentration.

[0015] This is an especially serious problem where the patient is prone and secretions can be present which are drawn into the opening 31 at the tip 30 and which then either partially or totally occlude the opening 31, during the administration of anesthesia.

[0016] The anesthesiologist must respond by clearing the nare opening after first removing the cannula from its location on the face of the patient. This may be complicated where the patient is draped in a manner which covers the cannula, such as in eye surgery. It may also be difficult to detect the occlusion where the end-tidal carbon dioxide measurement signal is only partially degraded.

[0017] It has been discovered that the expedient of additionally providing the nares with very small holes, shown collectively at **35** and **36** and **37** and **38**, achieves the desired result of preventing an undesirable and unnecessary level of suction at the opening **31** of the tip **30** from developing sufficiently to draw the opening **31** into the nasal tissue thereby occluding the opening. The holes are sized large enough to prevent sufficient suction from developing at the tip **30** to draw in mucosal secretions or attach the tip by suction to the soft mucosal tissue, while still drawing an undiluted sample of the exhaled gases to provide good end-tidal carbon dioxide measurements. Likewise, too large an opening for these holes would undesirably dilute the exhaled gas sample with room air or excess insufflation gas.

[0018] Most preferably, as previously noted, the nasal cannula of the present invention can be used in combination with an oxygen delivery system that delivers the insufflating gas intermittently. The delivery can be initiated at any time after the peak end-tidal carbon dioxide measurement is achieved during exhalation and continuing into the inhalation phase of the breathing cycle or could be inhalation activated or designed to deliver only during selected portions of all or only some of the inhalation phases of a patient's breathing cycles. Preferably, the delivery should begin before the termination of the exhalation phase, such as is described in U.S. Pat. No. 5,626,131. Using intermittent delivery substantially reduces the possibility of distorted carbon dioxide readings due to gas mixing.

[0019] Likewise, slits or slots (not shown) may be employed in the nares which could function in the same manner as the holes described if they are positioned in such a manner to avoid collapse or occlusion with the nasal tissues and provide the desired function of preventing sufficient suction from developing at the tip of the nare to cause it to be drawn, by suction, onto the tissues. The holes provided as described herein are preferred as there is less risk of occlusion and trauma from the edges of slits or slots to the nasal tissue and potentially there is less risk of gas dilution and mixing from occurring where the slits or slots are overly large.

[0020] Further, the combination of intermittent insufflation using the cannula of the present invention produces the desired end-tidal carbon dioxide measurement, as described, and helps prevent patient desaturation during the rigors of surgery and anesthesia administration.

[0021] Preferably, the size of the openings is from between about 0.05 to about 0.07 inches though larger or smaller holes or single holes may be advantageously employed in combination with specific analytical apparatuses. The size and location of the openings can vary with the analyzer selected and the proper function confirmed without undue experimentation.

[0022] The invention described herein is to be limited only by the scope of the appended claims and the applicable prior art.

What is claimed is:

1. An apparatus for insufflating a treating gas into the nose of a patient and measuring carbon dioxide content in the exhalation of the patient, said apparatus consisting of:

an elongated hollow body including a tubular portion adapted to be received on the skin surface adjacent the nose;

a wall within said hollow body defining therein both an inhalation manifold and an exhalation manifold, said wall providing a gas-tight seal positively preventing fluid communication between said inhalation and exhalation manifolds;

supply means for connecting said inhalation manifold to a supply of treating gas;

a first hollow prong in fluid communication with said inhalation manifold and adapted to be received in a first nasal passage of the nose for insufflating said treating gas into the nose;

a second hollow prong in fluid communication with said exhalation manifold and adapted to be received in a second nasal passage of the nose for withdrawing a portion of the exhalation therefrom, said prongs each being substantially smaller in diameter than the respective nasal passages, so as not to occlude said passages; and

at least said second prong being provided with at least one additional opening communicating with the hollow interior of said second prong and said exhalation manifold; and

means for measuring the concentration of carbon monoxide in the exhaled gases said means including means for withdrawing an exhaled gas sample from said exhalation manifold.

2. A method for monitoring end tidal CO₂ in unintubated, conscious, spontaneously breathing patients who are receiving administration of local and regional anesthesia or during recovery from residual general anesthesia consisting of the steps of:

providing a nasal cannula on a patient, said cannula having an elongated hollow body; a gas-tight partition in said hollow body to divide said hollow body into a first zone and a second zone separated from each other by said gas tight partition; gas supply means including first conduit means communicating with said first zone and a source of oxygen, second conduit means communicating with said second zone and communicating with a means for detecting and measuring the partial pressure of carbon dioxide in the exhaled gases said elongated hollow body in addition containing separate hollow nasal prongs each communicating with one of said first and second zones and with respectively each nostril of the patient;

supplying oxygen to said patient from said source of oxygen through said first conduit means to said first zone of said elongated hollow body and into the patient's nostril through one of said nasal prong means;

withdrawing exhaled breath containing carbon dioxide from said patient through the other of said nasal prongs into said second zone of said elongated hollow body,

through said second conduit means and into said means for detecting and measuring the partial pressure of carbon dioxide; and

determining the partial pressure of carbon dioxide at the end of the patient's exhalation to obtain a clinical approximation of the partial pressure of arterial carbon dioxide, wherein the other of said hollow nasal prongs is provided with an opening in addition to the diameter of the opening of said nasal prong and sized to prevent the withdrawing of exhaled breath from causing occlusion of said hollow nasal prong by adjacent tissue or patient secretions.

3. A nasal cannula comprising a face piece consisting of an elongated hollow body terminating at both ends in tubular cross section portions, two hollow nares communicating with the interior of said hollow body protruding in parallel from positions adjacent the center of the hollow body and spaced apart a sufficient distance and each of sufficient length for the open terminus of said nare to be received in or adjacent to the nostrils of a patient, and a fluid tight wall located between the hollow nares inside of the hollow body to prevent fluid communication between the nares inside of the hollow body,

at least one of said nares being provided with at least one opening other than the opening into the hollow body or the opposite terminus of said nare, said opening being sized to prevent suction applied to said nare from a carbon dioxide analyzer from drawing the open terminus of said nare onto the adjacent tissue of the patient's nostril whereby the nare would become occluded and located sufficiently near the terminus of said nare to

receive exhalation gases substantially undiluted by atmospheric gases during sampling by a carbon dioxide analyzer.

4. A system for insufflating a treating gas into the nose of a patient and for measuring the carbon dioxide concentration of the patient's exhaled breath consisting of:

a source of insufflating gas;

first conduit means connected to and in intermittent fluid communication with said source of insufflating gas;

cannula means connected to said first conduit means and in fluid communication with said source of insufflating gas and at least one nostril of a patient;

means for drawing a portion of the patient's exhaled gases and measuring the concentration of carbon dioxide in the patient's exhaled gases;

second conduit means connected to and in fluid communication with said drawing and measuring means, said second conduit means being connected to said cannula means and in fluid communication with at least one other nostril of a patient whereby the gas delivery occurs only after the peak carbon dioxide concentration is measured in each breath exhalation cycle; and

wherein said cannula means includes multiple fluid communication means for means in communication with said drawing and measuring means.

5. The system of claim 4 wherein the cannula means includes at least two hollow nares each one of said two hollow nares only in fluid communication with either said source of gas or said drawing and measuring means.

* * * * *