



- (51) International Patent Classification: Not classified
- (21) International Application Number: PCT/IB2012/002671
- (22) International Filing Date: 11 December 2012 (11.12.2012)
- (25) Filing Language: English
- (26) Publication Language: English
- (30) Priority Data: BG2012A000005 30 January 2012 (30.01.2012) IT
- (71) Applicants: **INSIS S.P.A.** [IT/IT]; Via delle Pianazze, 74, I-19126 La Spezia (IT). **FLOW-ING S.R.L.** [IT/IT]; Viale San Bartolomeo, 777/16, I-19126 La Spezia (IT).
- (72) Inventors: **BARBOLINI, Massimiliano**; Via Tolone, 22, I-19124 La Spezia (IT). **FERRO, Francesco**; Viale della Vittoria, 5, I-19036 San Terenzo di Lerici (SP) (IT). **BAUDONE, Matteo**; Via Palvotrisia, 22, I-19033 Castelnuovo Magra (SP) (IT). **RICCHETTI, Laura**; Via Gramsci, 31, I-19020 Vezzano Ligure (SP) (IT).
- (81) Designated States (unless otherwise indicated, for every kind of national protection available): AE, AG, AL, AM, AO, AT, AU, AZ, BA, BB, BG, BH, BN, BR, BW, BY, BZ, CA, CH, CL, CN, CO, CR, CU, CZ, DE, DK, DM,

DO, DZ, EC, EE, EG, ES, FI, GB, GD, GE, GH, GM, GT, HN, HR, HU, ID, IL, IN, IS, JP, KE, KG, KM, KN, KP, KR, KZ, LA, LC, LK, LR, LS, LT, LU, LY, MA, MD, ME, MG, MK, MN, MW, MX, MY, MZ, NA, NG, NI, NO, NZ, OM, PA, PE, PG, PH, PL, PT, QA, RO, RS, RU, RW, SC, SD, SE, SG, SK, SL, SM, ST, SV, SY, TH, TJ, TM, TN, TR, TT, TZ, UA, UG, US, UZ, VC, VN, ZA, ZM, ZW.

- (84) Designated States (unless otherwise indicated, for every kind of regional protection available): ARIPO (BW, GH, GM, KE, LR, LS, MW, MZ, NA, RW, SD, SL, SZ, TZ, UG, ZM, ZW), Eurasian (AM, AZ, BY, KG, KZ, RU, TJ, TM), European (AL, AT, BE, BG, CH, CY, CZ, DE, DK, EE, ES, FI, FR, GB, GR, HR, HU, IE, IS, IT, LT, LU, LV, MC, MK, MT, NL, NO, PL, PT, RO, RS, SE, SI, SK, SM, TR), OAPI (BF, BJ, CF, CG, CI, CM, GA, GN, GQ, GW, ML, MR, NE, SN, TD, TG).

Declarations under Rule 4.17:

— of inventorship (Rule 4.17(iv))

Published:

— without international search report and to be republished upon receipt of that report (Rule 48.2(g))



WO 2013/114151 A2

(54) Title: AUTOMATED ELECTRONIC METHOD FOR PERIODICAL CONTROL OF SNOWPACK CONDITIONS

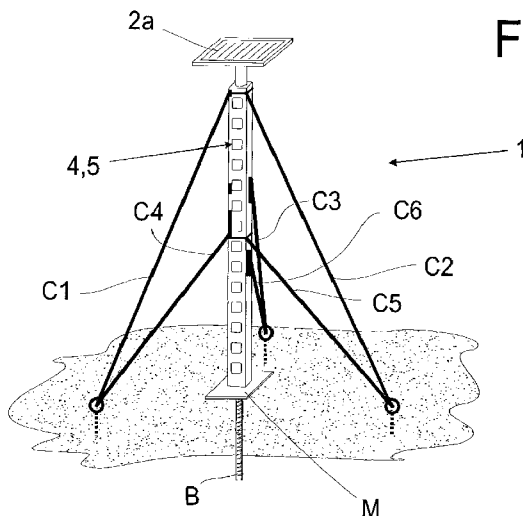

Fig. 1

(57) Abstract: Automated electronic method for the periodical verify of the snowpack conditions, having the particularity of comprises a data collection system which acts by the means of sensors mounted on a ranging rod, permanently fixed to the ground by usual methods (E, M, C), a system of battery power (2) and a system of processing of collected data and telecommunication (7) towards a remote server.

DESCRIPTIONTITLE

AUTOMATED ELECTRONIC METHOD FOR PERIODICAL
CONTROL OF SNOWPACK CONDITIONS

5

TECHNICAL FIELD

The present invention deals with a method of measurement and monitoring of the snowpack conditions by means of an electronic ranging rod.

10 As is well known, phenomena of accidental detachment of avalanches pose a high threat to every urbanized mountain area, especially to ski districts designed for winter sports. In this regard, safety management becomes a high-attention element, requiring great human and economic resources.

15 Useful elements for risk evaluation, planning of safeguarding measures and incident prevention basically focus on snowpack characteristics.

In particular, the most important element is its thickness, as well as its time variability.

20 The chance to foresee with enough reliability snow-covered mountainsides detachments, which results in avalanches potentially dangerous for human settlements, allows the implementation of measures, like evacuations, road

interruptions, ski resorts closure and so on, able to hold damages down.

Thanks to a detailed knowledge of the snowpack physical characteristics, it's also possible to wisely plan the construction
5 of defense structures (such as snow barriers) to reduce the costs.

In regard to the quantitative (thickness) and qualitative (stratigraphy) snowpack features, the State of the Art envisages two alternative operational modes.

10 The first mode is based on the installation of automated nivometeorological stations, provided with ultrasound nivometric sensors which supervise in real time the snow thickness, as well as other generic sensors for the survey of other usual climatic parameters (temperature, air pressure and so on).

15 Such first operational mode has some inconvenient elements. The main one is characterized by the impossibility to install such stations in the most critical points for avalanche detachments (steep sloped ground), due to technical requirements for a level and sheltered wide area.

20 Another critical aspect of such option is the lack of data on the internal physical conditions of the snowpack, which are helpful to predict the insurgence of possible instability conditions. Finally, building automated stations requires huge economic investments, usually hardly affordable for territorial entities operating in a

mountain area, such as small towns, mountain communities or small ski resort management trusts.

The second operational mode at the State of the Art requires the placement of manual nivometric stations, so-called snow camps, where the snowpack height survey is obtained by an operator through a daily visual reading of a graduated rod stucked into the ground.

Near snow camps, or in "extemporary" snow camps (also called "traveling" snow camps), periodical stratigraphic researches also take place.

These are directed to learn about snow characteristics inside the snowpack, such as number of layers, layer hardness and density, grain shape, temperature profile and so on.

This second option gives more information than automated stations; however it's unable to give real time information and, involving one or more operators, can only take place in accessible and free from avalanche danger zones.

This makes such an option inadequate to provide fully representative information about snowpack conditions in avalanche detachment areas, especially in situations of high nivometeorological criticality.

Due to the above said operational limits of the current methods of snowpack features surveying in reference to potential

avalanche detachment areas, additional measuring takes place in such areas by means of nivometric ranging rods.

These are graduated rods installed in detachment areas during summertime and partially buried in the snow during the cold
5 season.

The ranging rods are periodically read, in case of possible avalanches, by means of binoculars or approaching them on a helicopter.

This added option has the advantage of possible measurements
10 in the most critical areas, though reporting strong restrictions due to its dependence on visibility conditions, possibly becoming inadequate during atmospheric disturbances.

Furthermore such measurements just concern the snowpack height, not its internal characteristics, and could be very
15 expensive due to aircrafts use.

Therefore, aim of the present invention is to define a method allowing real time measuring, transmission and acquisition of the most important snowpack parameters.

Other aim is to define a method as above, allowing its use even
20 in the most critical locations, that is within areas of possible avalanche detachments.

Other aim is to define a method as above, allowing its realization with affordable charges even for small economic entities operating in mountain areas.

Other aim is to define any useful element for the implementation of such method.

These and other aims are going to appear as reached all through the reading of the following detailed description, showing a method for the measurement and monitoring of the snowpack conditions by means of an electronic multi-device ranging rod, and through the attached sketches, of which:

Figure 1 shows an axonometric synthetic dimetric view of a ranging rod, used for the experiment of the present invention method.

Fig. 2 shows schematically an electronic ranging rod, used for the experiment of the present invention method and its components.

Fig. 3 shows a cross section of a window provided with an optic filter and on the back side of the electronic card including various sensors.

Fig. 4 shows a perspective view of a ranging rod, used for the method experiment of the present invention, in a ladder version.

The elements included in the method are the following:

- 20 - A data collecting system
- An autonomous supply system
- A telecommunication system towards a monitoring server.

An example of the development phases including such elements, requires the use of a hollow ranging rod, firmly stack into the

ground. The ranging rod 1 has a number sensors detecting all the various characteristics of the snow pack, and includes a long lasting battery supply system.

In particular, the ranging rod 1 is provided with a tubular body 5 1a, approximately a square section bar, having inside an electronic card 3 supporting optical sensors 4, thermal sensors 5, eventual capacitive sensors 6; the ranging rod 1 includes also an electronic central unit 7 managing the sensors and including usual transmittal systems of data elaborated through 10 telecommunication over the air (for example TACS, GSM, GPRS, EDGE, UMTS, HSPA, LTE) to a remote server placed at consisting distance.

The fixing of the ranging rod 1 to the ground observes the specific exigencies of the static consolidation coming from the 15 nature of the installation site, in other words from the soil typology, the slope angle, expected high of the snowpack and its physical characteristics, the snow overload due to the wind.

In general, it is required the predisposition of an improved adherence steel anchor bar B, cemented in a hole of five 20 centimeters in diameter, hand-made by means of a hammer drill of suitable power.

The anchor bar B is a stable constraint for a metal plate M integrated with the tubular body 1a of the ranging rod 1.

Fastening the metal plate M and the bar B can require the bar B extremity tapping and a hold down nut D.

In addition to said constraint, it's advisable to arrange a wind bracing. This is for example constituted by two series of metallic ropes C placed at one hundred and twenty degrees around the ranging rod 1. The ropes are anchored to the ground by the means of generic systems; for example a ground anchorage similar to the one described for the bar B can be used, including anchor bars provided with fairlead rings R (e.g. eyebolts) to hook the ropes C.

The ropes C are hooked up to the body 1a at different heights to properly distribute the shear stress which the ranging rod 1 is subject to. Approximately, such separate hook up envisages a first series of three bracing ropes C1, C2, C3 bound to one third of the ranging rod height and a second rope series C4, C5, C6 bound to the two thirds of the ranging rod height. In case of installation on slushy grounds, the plate M anchoring to the ground can envisage a precautionary realization of small foundation plinths.

The body 1a is provided with a series of windows 8 overlooking the mentioned sensors, closed by means of optical filters (9), for example plexiglass panels, to protect the electronic elements from the strong solar radiations that may occur at high altitudes, when the ranging rod leans out the snowpack.

The temperature sensors 5, typically semiconductor temperature sensors assisted by a pre-conditioning circuit suitable to adapt the tension/temperature relation in accordance with the well-known technology, should have a sensitivity in the order of one
5 tenth of a degree centigrade (0.1°C) and an accuracy between five tenths of a degree centigrade and one degree centigrade (0.5°C and 1°C).

The optical sensors 4, matched with the windows 8, intended to measure the snowpack height, should be distributed along the
10 body 1a height at constant intervals, approximately between five and twenty centimeters, in order to assure the adequate accuracy. As for the present example, each optical sensor 4 is constituted by an infrared emission LED-photodiode couple, emitting and receiving a square wave of a preset frequency, as to
15 well-known technology.

The battery supply system 2 is dimensioned to allow a minimum of six-months functional autonomy, which is a winter season typical length, with an output capable to power the whole electronic apparatus considering at least a data transmission a
20 day.

Such battery 2, reasonably positioned inside the ranging rod or in the ground at its base in order to avoid low temperatures exposure, could be assisted by photovoltaic panels 2a, placed upon the ranging rod, and should be able to power the ranging

rod even in critical conditions or in unexpected situations where more frequent surveys could help, approximately up to ten reading per day, for ten days.

As for the example of the present description, the battery 2 is a lead one, with a twelve Volts voltage and a 12 Ampere-hour capacity.

Another version of the present invention allows a ranging rod alteration 1b incorporating capacitive sensors 6 related to a particular ladder shape (Fig. 4), including two different tubular bodies kept together by clamps 10 and fixed to the ground with a single plate M1, or, as an alternative, a side by side installation of the ranging rods to allow an analysis of the signals transmitted through the snowpack by the capacitive sensors, to control its density and granulometric characteristics.

The data transmitted from the ranging rod 1 are received and processed by a remote monitoring server, which processes such data by the means of a dedicated software, activating the appropriate alert systems and recording them for statistical purpose.

The ranging rod 1 in the present description has clear advantages of an easy installation even in critical avalanche detachment areas, of functional autonomy and operating diversity that makes it a better choice compared to the other methods in the State of the Art described in the introduction.

A second option for the method in the present description allows a net shape installation of the ranging rods on specific (certain) monitored lands.

Such method requires to determine the specific position of each ranging rod installed through GPS (Global Positioning System) coordinates to develop managing and forecasting strategies from the control basis, even using different data acquisition frequencies depending on the alert level and eventually with the assistance of computational algorithms implementable in the management software.

CLAIMS

- 1) Automated electronic method for the periodical verify of the snowpack conditions, characterized by the fact that it includes a data collection system which acts by the means of sensors (4, 5, 6) mounted on a ranging rod (1), permanently fixed to the ground by usual methods (B, M, C, D and M1), a system of battery power (2) and a system of processing of collected data and telecommunication (7) towards a remote server.
- 2) Automated electronic method for the periodical verify of the snowpack conditions, as to claim 1, wherein the adopted ranging rod (1) includes a hollow pipe body (1a), for instance a square tube, having an internal electronic card (3) supporting optical sensors (4), temperature sensors (5) and an electronic control unit (7) for the management of the sensors and the transmission of the processed data by the means of the appropriate, well-known, methods of radio frequency telecommunications, as for an instance TACS, GSM, GPRS, EDGE, UMTS, HSPA, LTE.
- 3) Method, as to the previous claims, wherein each one of the optical sensors (4) are constituted by an infrared emission LED-photodiode couple, in accordance with the well-known technology, and are distributed along the height of the body

(1a) at constant intervals approximately between five and twenty centimetres, in order to ensure a sufficient accuracy of the measurement.

4) Method, as to the previous claims, wherein the temperature sensors (5) are constituted by semiconductor temperature sensors assisted by a pre-conditioning circuit act to adapt the relation between tension and temperature, in accordance with the well-known technology, and with an accuracy between five tenths of a degree centigrade and one degree centigrade.

5) Method, as to one or more of the previous claims, wherein the ranging rod incorporates capacitive sensors (6) and presents two tubular bodies (1b) formed in the shape of a ladder in order to measure the characteristics of density and particle size of the snowpack, in addition to its height.

6) Method, as to one or more of the previous claims, wherein two or more ranging rods (1) incorporating capacitive sensors (6) are placed in work side by side and conveniently spaced, to allow the analysis of the signals transmitted through the snowpack, in order to ascertain the characteristics of density and particle size.

7) Method, as to the previous claims, wherein the fixing of the ranging rod (1) to the ground occurs by cementing an improved adherence steel anchor bar (B) inside a hole of

approximately five centimetres of diameter realized manually by the means of a hammer drill of suitable power, and binding a metallic plate (M) to said bar (B) solidary to the tubular body (1a) of the ranging rod (1), said bind exemplifying taking place by rethreading the extremity of the bar (B) with a tap and with the use of a tightening nut (D), all dimensioned and respectful of the specific demands of static consolidation consequential to the nature of the installation site, that is the typology of the ground, the angle of slope, the attended height of the snowpack and its relative physical characteristics, the snow overload due to the wind.

- 8) Method, as to the previous claims, wherein the fixing of the ranging rod to the ground is assisted by a windbracing constituted by two series of metallic ropes (C) disposed at one hundred and twenty sexagesimal degrees around the ranging rod (1) and bonded to the ground by the means of generic anchorage systems, the hookup of said two series of bracing ropes foreseeing a first series of three ropes (C1, C2, C3) bound to one third of the height of the ranging rod, and a second series of ropes (C4, C5, C6) bound to the two thirds of the height of the ranging rod.
- 9) Method, as to the previous claims, wherein the body (1a) of the utilized ranging rod (1) is provided of a series of

windows (8) overlooking the mentioned sensors (4, 5 6), impermeably closed by the means of optic filters (9) with the purpose of protecting the electronic elements from the strong solar radiations that could occur at a high altitude, distributed on the height of the body (1a) at constant intervals and approximately between five and twenty centimeters.

5
10) Method, as to the previous claims, wherein the system of battery power supply (2) is exemplifying constituted by a lead battery, with a voltage of twelve Volts and a capacity of 10
12 Ampere-time, or rather dimensioned to allow a six months least functional autonomy with an output capable to power the whole electronic apparatus in the forecast of at least one event-transmission of data a day, said battery (2) being
15 positioned in the inside of the ranging rod or at its base to avoid extreme temperatures, and eventually assisted by photovoltaic panels (2a) to be positioned above the ranging rod (1).

20
11) Method, as to the previous claims, wherein the installation of the ranging rod (1) on a specific territory to monitor, is effected like a net, where the spatial coordinates of each ranging rod (1) are well known, for example by GPS system, to the remote control basis, also effecting different frequency in the acquisition of the data in reason of the level

of alert in course, and with eventually the aid of algorithms of computation of the data, implementable in the management software used by the remote control server.

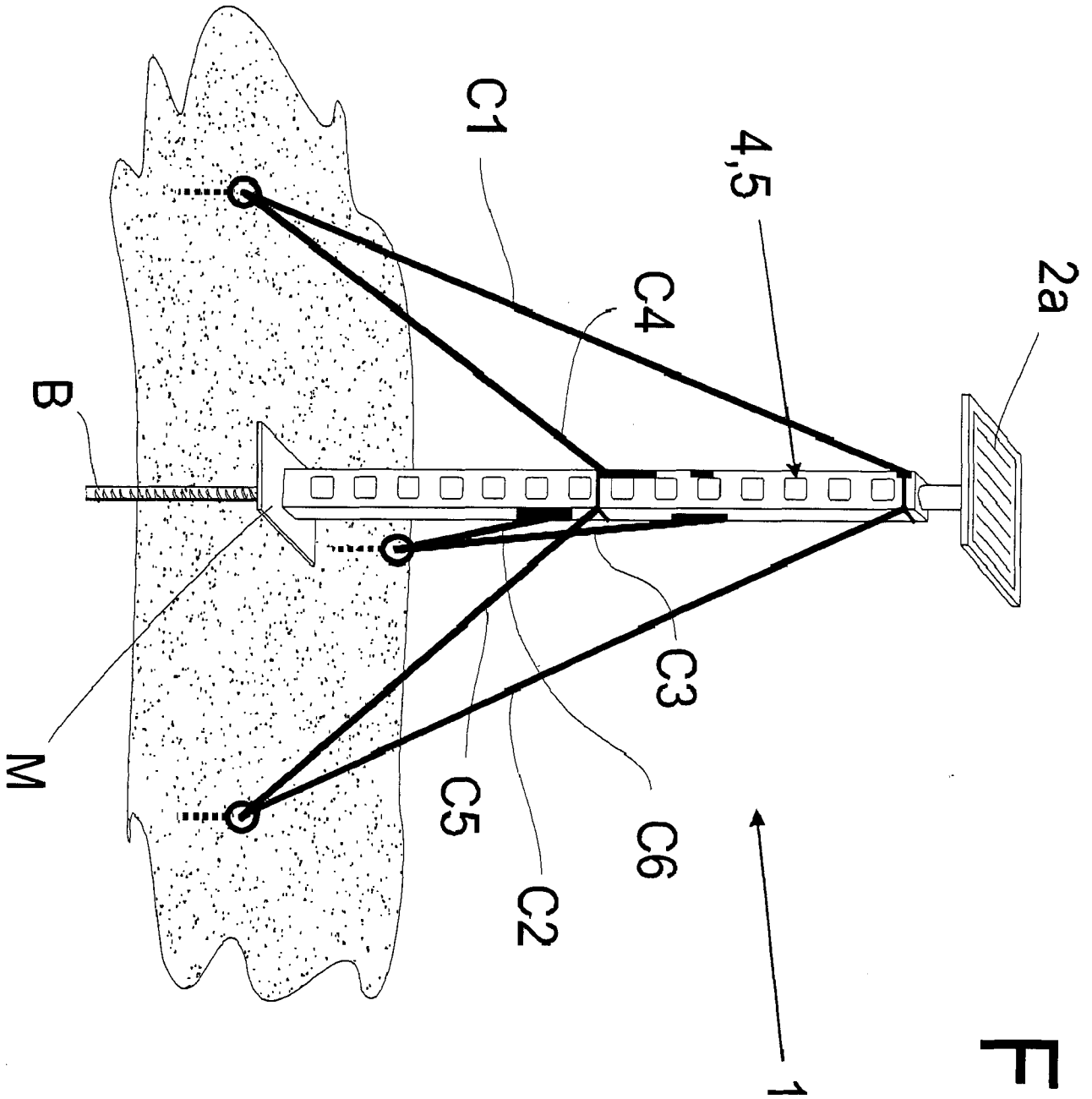

Fig. 1

Fig.2

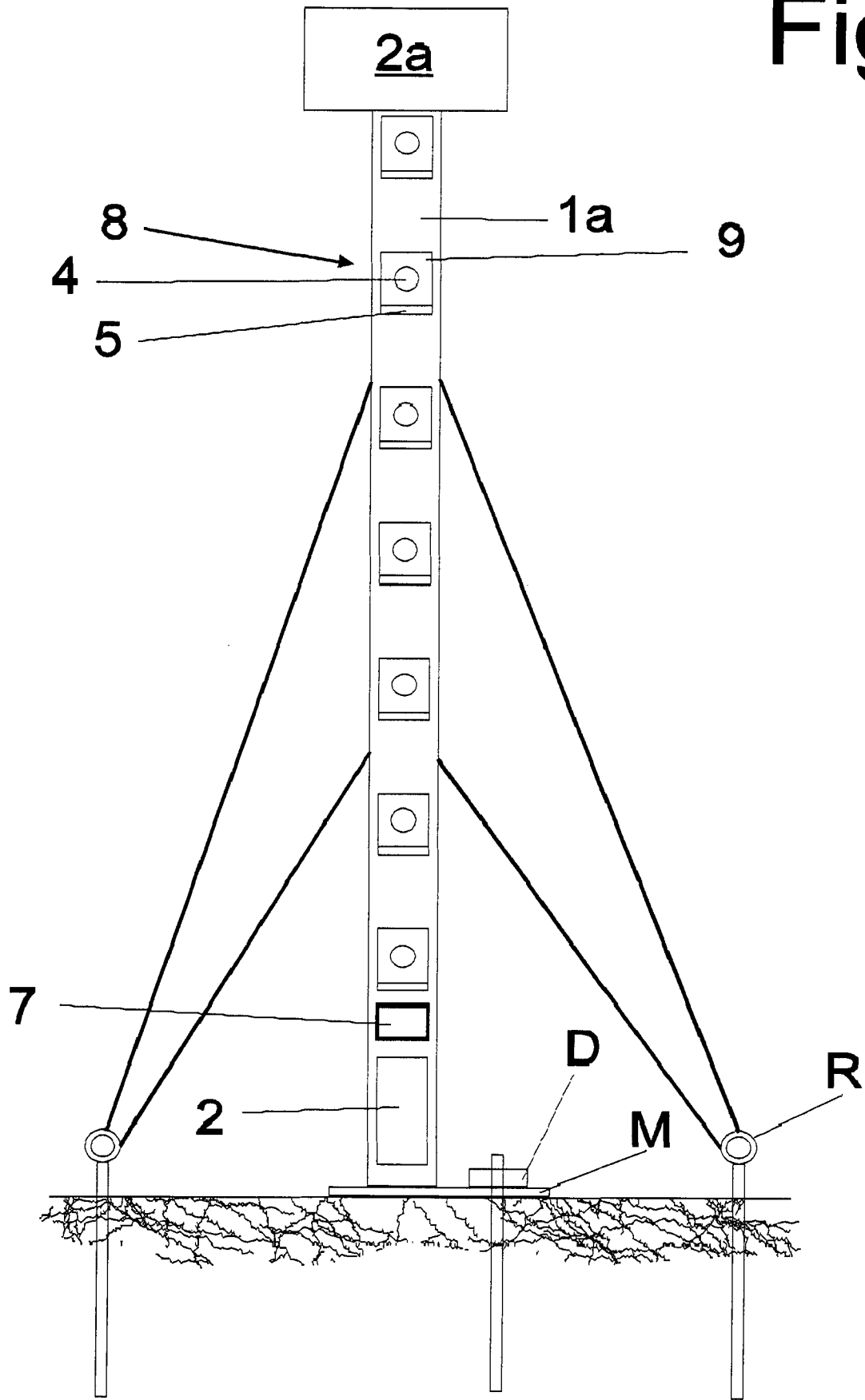

Fig.3

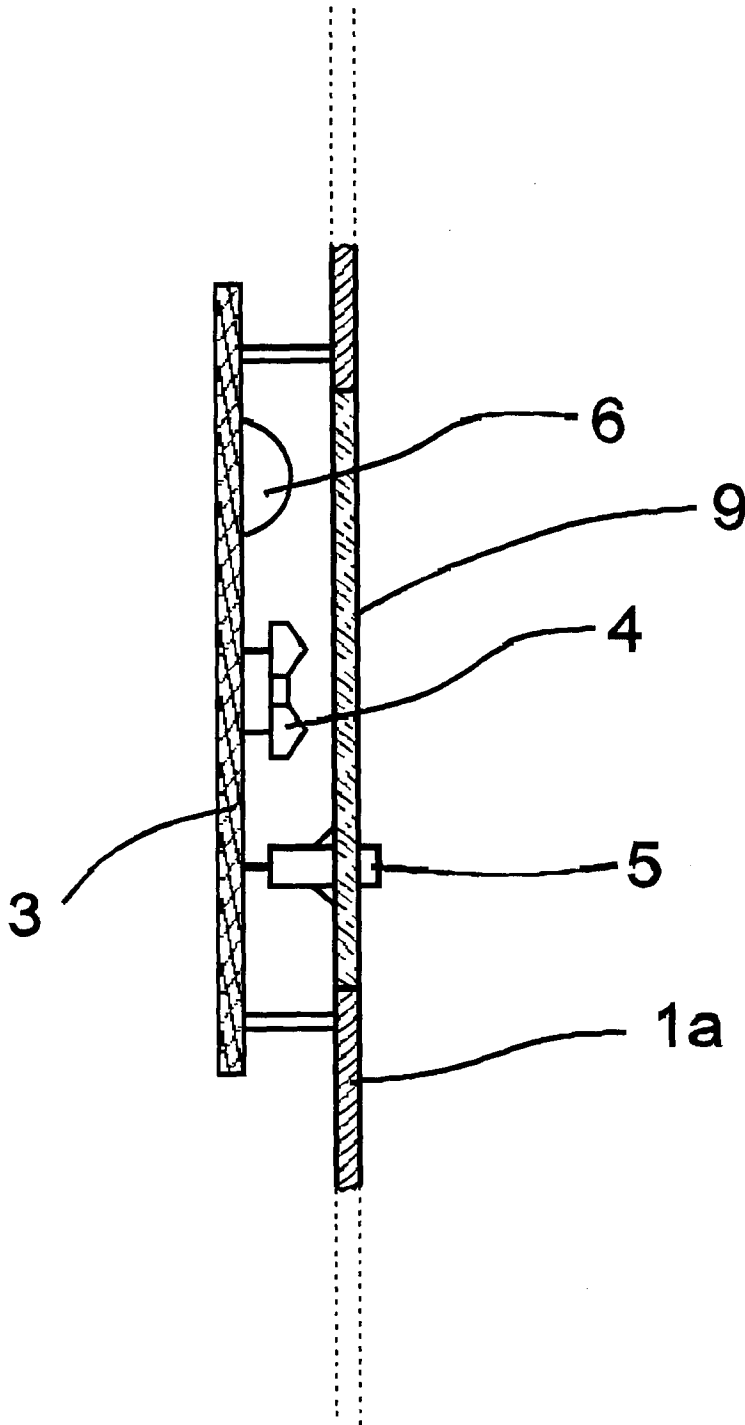

Fig.4

