



(11) **EP 1 628 548 B1**

(12) **EUROPEAN PATENT SPECIFICATION**

(45) Date of publication and mention of the grant of the patent:
10.10.2007 Bulletin 2007/41

(21) Application number: **04743753.8**

(22) Date of filing: **02.06.2004**

(51) Int Cl.:
A43B 13/14 ^(2006.01) **A43B 7/22** ^(2006.01)
A43B 7/14 ^(2006.01) **A43B 17/02** ^(2006.01)
A43B 21/26 ^(2006.01) **A43B 13/18** ^(2006.01)

(86) International application number:
PCT/IB2004/001887

(87) International publication number:
WO 2004/105546 (09.12.2004 Gazette 2004/50)

(54) **IMPROVED DORSIFLEXION SHOE**

DORSIFLEXION SCHUH

CHAUSSURE A DORSIFLEXION AMELIOREE

(84) Designated Contracting States:
AT BE BG CH CY CZ DE DK EE ES FI FR GB GR HU IE IT LI LU MC NL PL PT RO SE SI SK TR

(30) Priority: **02.06.2003 US 474910 P**

(43) Date of publication of application:
01.03.2006 Bulletin 2006/09

(73) Proprietor: **Springboost S.A.**
1015 Lausanne (CH)

(72) Inventors:
• **FUCHSLOCHER, Jörg**
CH-1015 Lausanne (CH)
• **BEHROUZ, Bayat**
CH-1006 Lausanne (CH)

(74) Representative: **Mötteli-Mantelli, Novella**
c/o Moetteli & Associés SàRL,
St. Leonhardstrasse 4
9000 St. Gallen (CH)

(56) References cited:
WO-A-02/30228 **US-A- 2 518 649**
US-A- 3 472 508 **US-A- 3 964 181**
US-A- 3 990 159 **US-A- 5 265 354**
US-A- 5 491 912 **US-A- 6 158 151**
US-A1- 2002 017 039 **US-A1- 2002 026 730**
US-A1- 2002 112 373

• **DATABASE EPODOC EUROPEAN PATENT OFFICE, THE HAGUE, NL; XP002312772 & HK 1 047 380 A (KO YEE MEI MIMIEUX) 7 February 2003 (2003-02-07) -& WO 03/055343 A (KO YEEMEI MIMIEUX) 10 July 2003 (2003-07-10)**

EP 1 628 548 B1

Note: Within nine months from the publication of the mention of the grant of the European patent, any person may give notice to the European Patent Office of opposition to the European patent granted. Notice of opposition shall be filed in a written reasoned statement. It shall not be deemed to have been filed until the opposition fee has been paid. (Art. 99(1) European Patent Convention).

Description

Background of the Invention

[0001] This invention relates to shoes, and, more particularly, to leisure and athletic shoes that promote dorsiflexion.

[0002] In standard shoes, the metatarsal phalangeal joints remain in a bend position at take-off and is unable to generate any energy during jumping and only a very small amount of energy during running due to the fact that the shoe does not straighten until after take-off when any return of energy is too little, too late, having no influence on performance. The used energy is therefore lost and useless for aiding propulsion in jumping or running. Over the past years, specialized track and field shoes have progressed in that they have begun to have relatively stiff midsoles.

[0003] In contrast, general athletic shoe manufacturers seem to be moving toward running shoes that are more flexible at the metatarsal phalangeal joint by either increasing the flexibility of materials used in their manufacture or by modifying the structure of the midsole (e.g., incorporating flexion grooves). This, unfortunately, has no benefit with respect to propulsive performance and is driven by pre-conceived notions.

[0004] During athletic activities, analysis of resultant joint moments and joint power indicate that for each joint, there are phases when energy is absorbed and phases when energy is generated. If the absorbed energy is dissipated and not stored for later re-use, it is wasted (i.e., it merely generates heat). If the stored energy can be reused, then performance can be increased.

[0005] The metatarsal phalangeal joint is one joint which, heretofore, has been a sink for energy dissipation and very little energy generation at or before take-off. This is because an athlete's foot rolls onto the forefoot and does not plantarflex until after take-off.

[0006] US Patent Application Serial No 09/833,485 to Whatley, published as US 2002 026 730, describes a shoe that utilizes dorsiflexion in an effort to increase the working of the certain muscles during exercise, with particular emphasis on enabling a larger range of motion of the foot so as to better work the calf. Dorsiflexion is brought about by a shoe which is inclined backwards (i.e., declined) to that of a normal plantar shoe. Essentially, instead of the heel being supported at a point higher than the toe, the inverse is true, with the angle of reverse incline being approximately 10 degrees. The shoe has proven to be extraordinarily stable. However, the incline of 10 degrees and the particular clumsy appearance of the shoe have limited its marketability and usefulness to all but those who are professional athletes.

[0007] Because of the dorsiflexion, one must ensure a rolling effort of the foot in order to avoid harm to the user's musculature and joints. The form of the sole, in which, in a forward end of the sole, the sole is thicker and of a cylindrical form, is such that it approximates the nat-

ural rolling effect of the foot. Fig. 21A of the above-mentioned patent application shows a shoe which most nearly approaches that of the invention.

[0008] Furthermore, document WO 03/055 343 discloses an adaptable shoe with the features of the preamble of claim 1 and 2.

[0009] What is needed is an athletic shoe that takes advantage of the energy generation capacity of the metatarsal phalangeal joint. Further, what is needed is an improved dorsiflexion shoe that takes better advantage of the mechanism of dorsiflex action in order to gain improved power output, comfort and performance. Still further, what is needed is a dorsiflex shoe that has a more conventional form, in order to improve the marketability and comfort of the shoe.

Summary of the Invention

[0010] An adaptable shoe assembly is disclosed in claim 1 and 2. Preferred embodiments are disclosed in dependent claims 3 to 5.

Brief Description of the Drawings

[0011]

FIG. 1 is a cross-sectional side view of the shoe of the invention.

FIG. 2A is a section view taken along line A-A of FIG. 1, showing the constraining strap of the invention in an uncinched position.

FIG. 2B is a section view taken along line A-A of FIG. 1, showing the constraining strap of the invention in a cinched position.

FIG. 3A is a cut-away view showing the reinforced toe region of the invention.

FIG. 3B is a perspective view of the reinforced, high density plate disposed in the forefoot region of the sole of the invention.

FIGs. 4A to 4B are partial cut away/cross sectional, longitudinal views of the invention showing two configurations of interchangeable insoles.

FIG. 7A is a cross-sectional side view of another embodiment of the invention having a composite sole assembly.

FIG. 7B is a bottom view of the embodiment of FIG. 7A.

FIG. 8 is a cross-sectional side view of another embodiment of the invention.

FIG. **9A** is a table showing different embodiments of the power plate of the invention.

FIG. **9B** is a top view of a power plate of the invention.

FIG. **10A** is a top view of an insole of the invention.

FIG. **10B** is a cross-sectional side view, taken along line B-B of FIG. **10A**.

Detailed Description of the Preferred Embodiment

[0012] In the preferred embodiment, as shown in FIG. 1, a high performance dorsiflexion shoe 10 has a shell 12, an upper 14, and a constraining device 16 above the metatarsal-phalangeal joint 20. The shell 12 has a sidewall portion 22 with an upper edge 13. The sidewall portion 12 is connected to a sole portion 24. The sole portion 24 has a ground-contacting surface 26, a forefoot region 30, a midfoot region 32 and a heel portion 34. The forefoot region 30 is made of a high density material, and has a thickness T , measured in a direction perpendicular to the ground-contacting surface 26 of the sole portion 24, greater than the thickness t of the heel portion 34, thereby defining a characteristic angle α of declination from the forefoot region 30 to the heel portion 34. The constraining device 16 substantially constrains a wearer's metatarsal-phalangeal joints 20 from movement when exercising. The forefoot region 30 has a curved region 28 defined so as to further minimize flexion of the metatarsal-phalangeal joint 20.

[0013] The angle α of declination may vary significantly, from between 1 degree and 15 degrees. The preferred angle is 5 degrees.

[0014] Referring now to FIGs. **2A** and **2B**, the constraining device 16, just below the upper 14 of the shoe 10, above the metatarsal-phalangeal joint 20 of the wearer, restrains the top 36 of the foot 40 against the sole portion 24 in order to prevent this unfruitful or wasted motion (and thus prevent energy waste). A cinchable strap 42 having one end 44 connected adjacent the metatarsal-phalangeals and the other end 46 threaded through a loop 50 attached to the opposite side 52 of the metatarsal phalangeals, transverse to the connection point 54, has an extreme end 56 which includes a "VELCRO"TM backing 60 that mates with a corresponding backing 61 on the upper, such interlocking "VELCRO"TM arrangement enabling locking of the strap in place after cinching. Note that the strap may be fabricated as part of the tongue, be attached to the outsole, and vary in width. Further, any known attachment arrangement may be used. Still further, a rigid comfort insert (not shown) may be attached between the strap 16 and the foot 40, the insert substantially conforming to the shape of the top of the foot above the metatarsal-phalangeal 20, thus increasing the comfort of the strap as it is cinched firmly against the metatarsal-phalangeal joint.

[0015] Referring now to FIG. **3A**, as one tries to max-

imize the lever, high stresses are applied in the toe region 62 of the shoe 10, especially as the shoe just leaves contact with the ground and thus, the foot 40 (particularly the toe) must be protected. Therefore, in a feature of the invention, the toe region 62 is padded with a compressible material 64 for comfort and support and a rigid, curved power plate 66, insert molded below the toe is made of a very high density composite material 70. Note that the fact that now, the forward stress normally applied to the region of the shoe just above the toe 62 is no longer needed to restrain the foot or absorb forces - forward forces are now absorbed by the strap 16. Further, the high power plate 66 below the toe 62 in the region designated by reference numeral 66 provides support so that the toe no longer needs to support the end of the foot - this is accomplished by the strap 16 working in combination with the power plate 66 which now performs the equivalent function of the toe, thus reducing fatigue of the foot. On the other hand, the heel portion 34 is substantially comprised of a low density, viscous-like material, particularly adapted to fitness and training shoes (note that for competition, this viscous-like material is generally not appropriate - the actual sole design will be made of materials which suit the intended surface and sport).

[0016] Referring now to FIG. **3B**, the power plate 66 is a rigid ground effect guide which controls the running motion and effects transmission of forces to the ground and into the body of the user. The power plate 66 is rigidly formed in a curved shape, having an outward facing surface **80**, and an inward facing surface **82**, connected by a thin sidewall **84**. The board 66 is optimized to reproduce, as accurately as possible, the natural rolling effect of the foot. For aesthetic reasons, to provide better sole life, and to ensure firm fixing of the spring broad 66 in the softer sole portion 24 or shell 12 in the insert molding process, ribs 90 are provided in the outward facing surface 80 and extend completely through an endo layer 92 so as to be expose a surface 91 to the outside of the shoe 10. Thus, the power plate 66 can be fabricated in different colors and the integral ribs 90 will thus be visible and add a pleasing multi-tone aspect to the shoe. The power plate 66 is preferably made of a material, having a shore hardness of between 20 and 90, whereas the endo layer 92 as well as the rest of the shell 12 is made of standard, soft material.

[0017] The measured stiffness of the shoe 10 in the region of the power plate 66 is selected so as to be in the range of 0,1N.M.Deg-1 and 0.5N.M.Deg-1. The shape, length, positioning and density of the power plate 66 vary depending on the intended sport or competitive application. In order to minimize impact on the metabolic cost of propulsion, the weight of the power plate 66 is in the range from 30 to 250 grams. Essentially, the power plate 66 is positioned so as to minimize flexing of the metatarsal phalangeal joint 20, in an effort to reduce energy loss at this joint, particularly during running and jumping.

[0018] The invention substantially reduces energy loss due to metatarsal-phalangeal flexing during running (including slow jogging from speeds of 2 meters/sec through fast sprinting at speeds of 10 meters/sec) and jumping (including any propulsive activity from submaximal hopping to maximal jumping in vertical, horizontal and lateral directions). The inventors have shown that, using the invention as compared to a conventional plantarflex shoe, jumping performance can be increased from 5% to 10%, and in running, by about 5%. Testing has shown that, in jumping, the power plate 66 absorbed an average of 24 J during one-legged jumping, assuming a body mass of 70 Kg, which corresponds to a difference in jump height of approximately 3.5 cm.

[0019] Referring now to FIG. 4A, in another embodiment, an adaptable dorsiflexion shoe assembly 100 includes a shoe 102 adapted to receive an interchangeable insole 104 which inserts into the shoe. The assembly 100 results in a dorsiflexion shoe defined by a particular angle β of declination. The insole 104 has weights 106 selected to provide a particular level of energy consumption during use. The weights 106 may be adjusted through the use of various configurations in which the weights are insert or injection molded into place in the insole 104 using, for example, a composite molding process at fabrication. In this manner, the shoe 102 of the invention is capable of interfacing with interchangeable insoles 104 of various weight, energy absorption capacity, rigidity, and form thus enabling the wearer a greater flexibility in configuring the invention for a particular type of sports activity corresponding to a particular angle of declination. Further, as the inventors have learned that, surprisingly, only a small angle of declination (5 degrees being ideal) contributes substantially to performance, it is not necessary to use a design corresponding to the bulbous sole design of the prior art. The result of this is that the weight of the shoe 10, 102 has been reduced. Consequently, the bulk in the sole portion 24 is greatly reduced and thus, an even greater range of weight of the shoe is possible.

[0020] Referring now to FIG. 4B, an insole 120 is shown in which corresponding, interlocking surfaces 122 and 124 help ensure that the insole does not move during operation.

[0021] Referring now to FIGs. 7A and 7B, in another embodiment, a dorsiflex shoe 150 is provided having a composite sole arrangement. A sole assembly 152 is made up of several layers and distinct regions including a sport-surface selected central region 154, a viscous-like heel portion 156, a reinforced forefoot region 160, a high density forward region 162, a medium density upper region 164, a low density region 166 in the rearward part of the shoe, below the wearer's heel, and a soft insole 170 for comfort and cushioning. The upper region 164 traverses the shoe 150 from the heel to the toe. A padded toe region 172 protects the wear's toes. Note that in FIG. 7B, region 156 is surrounded by the higher density region 174 or optionally, by high density regions 176, for improved lateral stability. Clearly, the region 156 may be

formed of various shapes and relative sizes, depending on the sport or surface against which it's intended to bear.

[0022] In the configuration shown in FIG. 4A, it is apparent that the insole 104 increases the thickness of the forefoot region 30 changing the shoe 102 from one which is plantarflex to a shoe assembly 100 which is dorsiflex. The inventors have learned that this presents challenges in forming the portion of the upper 14 so as to accommodate the changing amount of space inside the shoe assembly 100 available to accommodate the toes and the forefoot. Therefore, in another embodiment, shown in FIG. 8, insoles 104' are used which increase the thickness of the heel portion 34 changing the shoe 110 from one which is of maximum dorsiflexion of about 15 degrees (using the lowest heel point situated under the calcaneum bone where the foot takes a rounded shape) to a shoe assembly 112 which is plantarflex or 0 degree declination (i.e., barefoot posture).. The thickness of the insoles 104' varies by about 2.5-3 mm per degree of dorsiflexion.

[0023] The embodiment of FIG. 8 ensures that the form of the toe region 62 remains unchanged as insoles 104' are changed. As the degree of dorsiflexion is increased, the height of the heel portion is proportionally decreased without alteration of the portion of the insole extending from the back of the cuneiform bones and the cuboid to the toes. For example, in an embodiment configured to provide 4 degrees of dorsiflexion, the insole of the shell 12 will have a plus/minus variation of 10mm between the thickness in the metatarsal areas and the lowest point of the heel.

[0024] In another embodiment, the insoles 104' are designed so as to be stackable, lifting the heel in 2.5 mm to 15 mm increments which represent from 1 to 6 degree changes in dorsiflexion. The dashed line 108 indicates a possible location of the interface between two layering insoles 104". The insoles 104" are formed so that the first-installed insole 104" has a lower surface which conforms to the form of the shell 12, and an upper surface formed to adapt to a wear's foot 40, and the second-installed insole 104" formed to conform to the top surface of the first-installed insole, itself having a top surface that conforms to a wearer's foot. This provides the wearer with the ability to select the angle of declination, and thus the degree of dorsiflexion. It should be noted that the insoles 104' must also be constructed of a material having a comparable compression factor with the shell 12, in order to ensure the selected dorsiflexion performance in operation.

[0025] Still further, in order to create a shoe that does not appear, from the exterior to be a dorsiflex shoe, the side wall portion 22 rises up and surrounds the heel area of the wearer and continues in a direction toward the toe region 62 at an angle θ which is less than dorsiflex than the maximum dorsiflex attainable in the shoe. In this embodiment, the angle θ is in fact plantarflex, so that the dorsiflex configuration is only apparent to the wearer.

[0026] The insoles 104' are constructed anatomically

and is constructed of materials typically used for orthopedic applications in shoes, such materials selected so that the tolerance of deviation due to material expansion is low, shape memory characteristics high, which high cycling endurance in compression.

[0027] Referring now to FIG. 9A, a table is shown of varying embodiments of the power plate 66, 162, 180, 182, 184, 186, and 190 of the invention, which, as indicated, extend from the toe to the metatarsal phalangeal ("MF"), to the cuneiform bones, or to the heel, as the case may be. Note that in power plates 186 and 190, a thinned portion 186' and 190', respectively, connect a forefoot region to a heel region. With power plate 184, the special "S-shaped" form provides improved end-to-end resilience of the shoe 10 and further acts to improve the energy absorbing capacity of the sole by elastic flexion.

[0028] Referring now to FIG. 9B, in an alternate embodiment, longitudinal slits 200 may be molded or cut in the power plate 66 in order to better adapt the sole's characteristics to a particular sport of interest. In particular, the bending moment of inertia of the power plate 66 may be varied by selectively, depending on the sport, adding slits to the power plate 66. In particular cases, more than one power plate may be used within the same construction, insert molded parallel to each other, partially overlapping or in separate lengthwise segments.

[0029] Referring now to FIGS. 10A - 10B, a typical insole 104, 104', for use with the shoe 10 has an arch support 210. Only the cross-hatched portion 212 need have a variable thickness.

[0030] In operation, a traditional shoe provides for flexing of the metatarsal phalangeal 20, in order, anatomically, to maintain a reasonable footprint on the ground, to both improve traction and to reduce the stress on the wearer's toes 94. In fact, the metatarsal phalange 20 is the only part of the foot 40 (ankle excluded) that is actually bending during walking. The inventors have found that by increasing the stiffness of the sole portion 24 in the forefoot region 30, and further by restraining the top of the foot 40 above the metatarsal phalangeal region 20 (restraining the foot against bending of the metatarsals), the lever of the foot is increased. When the length of the lever can be increased, the moment is increased and thus the power output of the foot is increased, which results in a lengthening of the stride while running. The result is improved "toe off" and an extended range of motion, less energy deprecation in the toe area and a more efficient stride.

[0031] Increased efficiency of the stride leads to a corresponding reduction in strenuous training protocol and improved technique, which, consequently results in reduced injury risk often associated with overtraining.

[0032] In an advantage of the invention, the 5 degree dorsiflex angle 30 produces a shoe 10, 10' that appears to be significantly less clumsy, more natural and comfortable, and therefore, much more likely to be purchased and used by amateur athletes as well as professional athletes. The invention provides a reverse, dorsiflex to

the orientation of the foot, to a level which experimentation has shown produces the maximum power output, namely 5 degrees. In fact, the inventors have learned that there is no remarkable benefit to be gained by providing a shoe which a greater reverse dorsiflex incline of 5 degrees.

[0033] In another advantage, the fact that the angle of reverse incline is lesser with the invention as compared to dorsiflex shoes of the prior art, means that less material is required in manufacture. Less material equates to less cost in manufacture as well as a lower minimum weight to the shoe.

[0034] In another feature, the sidewall of the shell 12 is formed so as to give the impression that the shoe is a conventional plantarflex shoe.

[0035] In another advantage, the invention eliminates the need for the metatarsal-phalange joint to flex because the shoe itself reproduces the movement of this joint and the toes.

[0036] In an advantage, the invention substantially reduces energy loss due to metatarsal-phalangeal flexing during running and jumping.

[0037] In another advantage, the invention improves the capacity of the foot by improving its efficiency while minimizing the risk to harm to the foot by selecting the materials of the shoe to absorb stress and by reproducing the rolling motion of the foot.

[0038] In a further advantage, the shoe is configured to receive insoles which adjust the thickness of the rear of the shoe from extreme dorsiflex to plantarflex, thus avoiding morphological problems which occur where an insole is designed so as to increase the thickness of the forward portion of the sole from plantarflex to dorsiflex.

[0039] In another advantage, insoles may be stackably inserted into the shoe, thereby reducing the total bulk and weight of the assembly including all insoles which interface therewith.

[0040] In an advantage, the shoe improves the capacity of the foot by improving its efficiency. Thus, the risk of harm to the foot is minimized by selecting the materials of the shoe to absorb stress and by reproducing the rolling motion of the foot.

[0041] In another advantage, the shoe configuration allows for improved performance of the plantar flexor muscles.

[0042] In another advantage, the invention increases the power output of a runner and of forces applied to the ground. The athlete is able to run faster because stride length is increased and contact time of the foot on the ground is decreased.

Claims

1. An adaptable shoe assembly wherein the assembly includes:

a shoe having a sole portion (24) of a pre-deter-

mined angle of inclination, adapted to receive an interchangeable insole (104, 104'); and at least one insole which inserts into the shoe, the assembly changing the posture of a wearer's foot (40) from one angle in a range between dorsiflexion and plantarflexion to another angle in the range resuming in a shoe defined by an angle of declination different from the pre-determined angle, **characterised in that** the shoe is of a substantially normal plantarflexion form in which the metatarsal-phalangeal restraining device (16) is adjustable over the metatarsal-phalangeal joints (20) of the wearer with or without an insole (104, 104') installed, and the foot-contacting portion (26) of the sole portion (24) of the shoe is of a form which suitably interfaces with the foot (40) so that, when the insole is not installed, the shoe functions as a conventional plantarflexion shoe.

2. An adaptable shoe assembly wherein the assembly includes:

a shoe having a sole portion (24) of a pre-determined angle of inclination, adapted to receive an interchangeable insole (104, 104'); and at least one insole which inserts into the shoe, the assembly changing the posture of a wearer's foot (40) from one angle in a range between dorsiflexion and plantarflexion to another angle in the range resulting in a shoe defined by an angle of declination different from the pre-determined angle, **characterised in that** the forefoot region (30) includes at least one hard, high density insert (66, 162, 180, 182, 184, 186, 190) formed to follow the curvature of the sole portion (24).

3. The shoe of claim 2, wherein the at least one insert (182, 184, 186, 190) extends from the forefoot region to the heel portion.
4. The assembly of claim 2, wherein the assembly includes at least two insoles (104) of substantially differing weights, which alternatively insert into the shoe, providing the wearer with the ability to select a weight (106) to provide a particular level of energy consumption during use.
5. The assembly of claim 2, wherein the shoe is of a substantially normal plantarflexion form in which the metatarsal-phalangeal restraining device (16) is adjustable over the metatarsal-phalangeal joints (20) of the wearer with or without an insole (104, 104') installed, and the foot-contacting portion (26) of the sole portion (24) of the shoe is of a form which suitably interfaces with the foot (40) so that, when the insole is not installed, the shoe functions as a conventional plantarflexion shoe.

Patentansprüche

1. Anpassbare Schuhanordnung, wobei diese Anordnung enthält:

einen Schuh mit einem Sohlenabschnitt (24) von einem vorgegebenen Neigungswinkel, wobei der Schuh zur Aufnahme einer auswechselbaren Schuheinlage (104,104') ausgeführt ist; und
 zumindest eine Schuheinlage, welche in den Schuh einlegbar ist, wobei die Anordnung die Lage des Trägerfusses ändert, und zwar von einem Winkel im Bereich zwischen der Dorsiflexion und der Plantarflexion zu einem anderen Winkel in einem Bereich im Schuh, welcher durch einen Deklinationswinkel definiert ist, der vom vorgegebenen Winkel unterschiedlich ist, **dadurch gekennzeichnet, dass** der Schuh die im wesentlichen normale plantarflexionale Form aufweist, bei welcher die metatarsal-phalangeale Feststellvorrichtung - (16) über den metatarsal-phalangealen Verbindungsstellen (20) des Tragenden mit oder ohne eine Schuheinlage (104,104') angeordnet ist, und in welcher der den Fuss berührende Bereich (26) des Sohlenbereiches (24) des Schuhs eine Form aufweist, welche dem Fuss (40) in einer passenden Weise gegenüber liegt, so dass der Schuh als ein üblicher plantarflexionaler Schuh funktioniert, wenn keine Schuheinlage eingelegt ist.

2. Anpassbare Schuhanordnung, wobei diese Anordnung enthält:

einen Schuh mit einem Sohlenabschnitt (24) von einem vorgegebenen Neigungswinkel, wobei der Schuh so ausgeführt ist, dass er eine auswechselbare Schuheinlage (104,104') aufnehmen kann; und
 zumindest eine Schuheinlage, welche in den Schuh einlegbar ist, wobei die Anordnung die Lage des Trägerfusses ändert, und zwar von einem Winkel im Bereich zwischen der Dorsiflexion und der Plantarflexion zu einem anderen Winkel in einem Bereich im Schuh, welcher durch einen Deklinationswinkel definiert ist, der vom vorgegebenen Winkel unterschiedlich ist, **dadurch gekennzeichnet, dass** die Region des Vorderfusses (30) zumindest einen harten, hochdichten Einsatz (66,162,180,182,184,186,190) umfasst, welcher so geformt ist, dass er der Krümmung des Sohlenabschnittes (24) folgen kann.

3. Anordnung nach Anspruch 2, in welcher sich zumindest ein Einsatz (182,184,186,190) vom Vorderfussbereich bis in den Fersenbereich erstreckt.

4. Anordnung nach Anspruch 2, welche zumindest zwei Schuheinlagen (104) mit wesentlich unterschiedlichen Gewichten umfasst, welche in den Schuh alternativ einsetzbar sind, und welche dem Träger die Möglichkeit gibt, ein Gewicht (106) auszuwählen, mit dem ein bestimmtes Niveau des Energieverbrauchs während der Benützung sichergestellt ist. 5
5. Anordnung nach Anspruch 2, in welcher der Schuh die im wesentlichen normale plantarflexionale Form aufweist, bei welcher die metatarsal-phalangeale Feststellvorrichtung (16) über den metatarsal-phalangealen Verbindungsstellen (20) des Tragenden mit oder ohne eine Schuheinlage (104,104') angeordnet ist, und in welcher der den Fuss berührende Bereich (26) des Sohlenbereiches (24) des Schuhs eine Form aufweist, welche dem Fuss (40) in einer passenden Weise gegenüber liegt, so dass der Schuh als ein üblicher plantarflexionaler Schuh funktioniert, wenn keine Schuheinlage eingelegt ist. 10 15 20

Revendications

1. Ensemble de chaussure adaptable, l'ensemble comprenant :

une chaussure dotée d'une partie (24) de semelle d'un angle d'inclinaison prédéterminé, prévue pour recevoir une semelle intérieure (104, 104') interchangeable ; et 30

au moins une semelle intérieure s'insérant dans la chaussure, l'ensemble modifiant la posture du pied (40) d'un utilisateur d'un angle d'une plage entre la dorsiflexion et la flexion plantaire à un autre angle de la plage, donnant une chaussure définie par un angle de déclinaison différent de l'angle prédéterminé, **caractérisé en ce que** la chaussure présente une forme sensiblement normale de flexion plantaire dans laquelle le dispositif (16) de contrainte métatarsophalangien est réglable par-dessus les articulations métatarsophalangiennes (20) de l'utilisateur avec ou sans installation d'une semelle intérieure (104, 104'), et **en ce que** la partie (26) en contact avec le pied de la partie (24) de semelle de la chaussure présente une forme s'interfaçant de façon appropriée avec le pied (40) de sorte que, lorsque la semelle intérieure n'est pas installée, la chaussure fonctionne comme une chaussure classique à flexion plantaire. 35 40 45 50

2. Ensemble de chaussure adaptable, l'ensemble comprenant : une chaussure dotée d'une partie (24) de semelle d'un angle d'inclinaison prédéterminé, prévue pour recevoir une semelle intérieure (104, 104') interchangeable ; et 55

au moins une semelle intérieure s'insérant dans la chaussure, l'ensemble modifiant la posture du pied (40) d'un utilisateur d'un angle d'une plage entre la dorsiflexion et la flexion plantaire à un autre angle de la plage, donnant une chaussure définie par un angle de déclinaison différent de l'angle prédéterminé, **caractérisé en ce que** la région (30) de l'avant-pied comprend au moins un insert dur (66, 162, 180, 182, 184, 186, 190) à haute densité formé de façon à suivre la courbure de la partie (24) de semelle.

3. Chaussure selon la revendication 2, ledit ou lesdits inserts (182, 184, 186, 190) s'étendant de la région de l'avant-pied à la partie de talon.

4. Ensemble selon la revendication 2, l'ensemble comprenant au moins deux semelles intérieures (104) de poids sensiblement différents, s'insérant au choix dans la chaussure, donnant à l'utilisateur la capacité de choisir un poids (106) entraînant un niveau particulier de consommation d'énergie pendant l'utilisation.

5. Ensemble selon la revendication 2, la chaussure présentant une forme sensiblement normale de flexion plantaire dans laquelle le dispositif (16) de contrainte métatarsophalangien est réglable par-dessus les articulations métatarsophalangiennes (20) de l'utilisateur avec ou sans installation d'une semelle intérieure (104, 104'), et en ce que la partie (26) en contact avec le pied de la partie (24) de semelle de la chaussure présente une forme s'interfaçant de façon appropriée avec le pied (40) de sorte que, lorsque la semelle intérieure n'est pas installée, la chaussure fonctionne comme une chaussure classique à flexion plantaire. 25 30 35 40 45 50

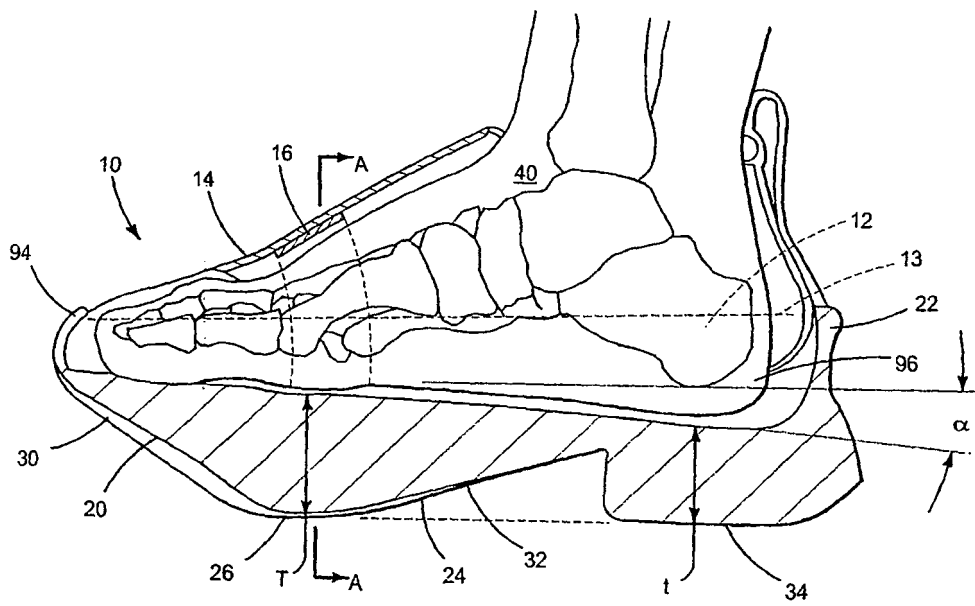

FIG. 1

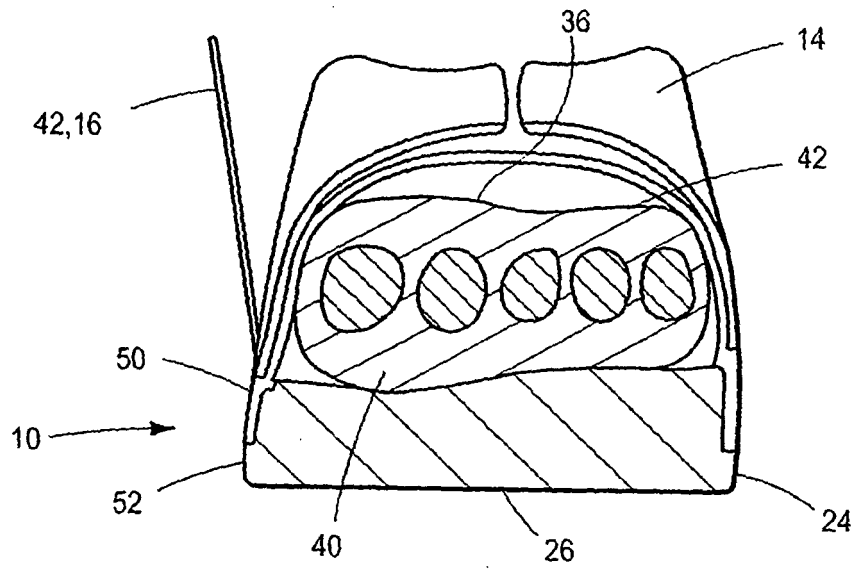

FIG. 2A

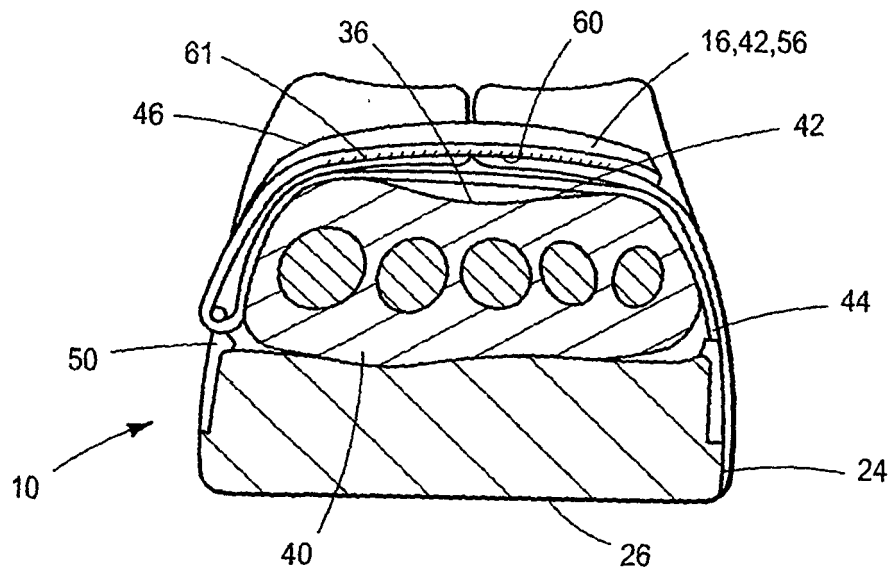

FIG. 3B

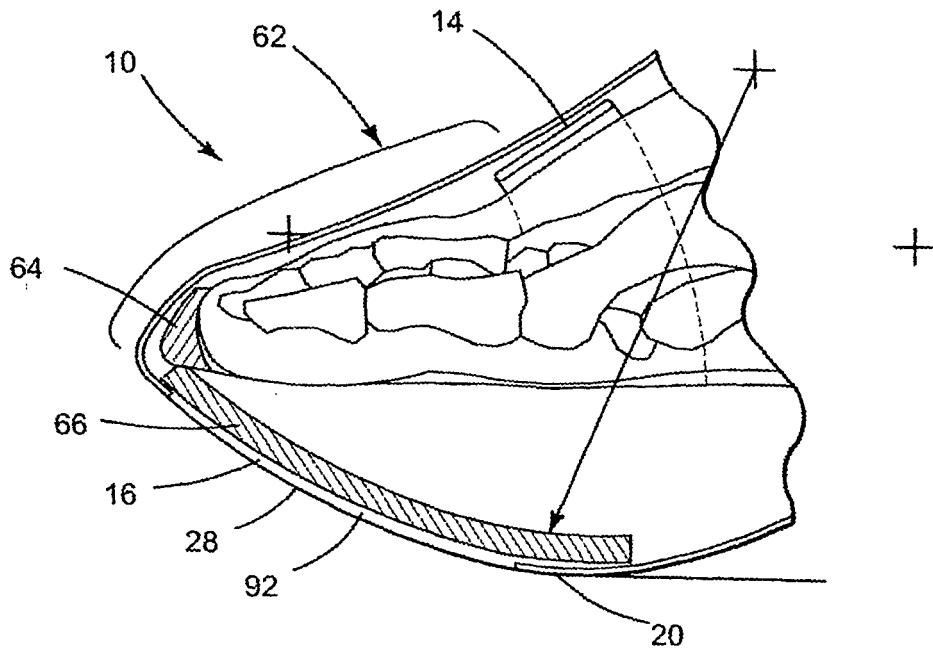

FIG. 3A

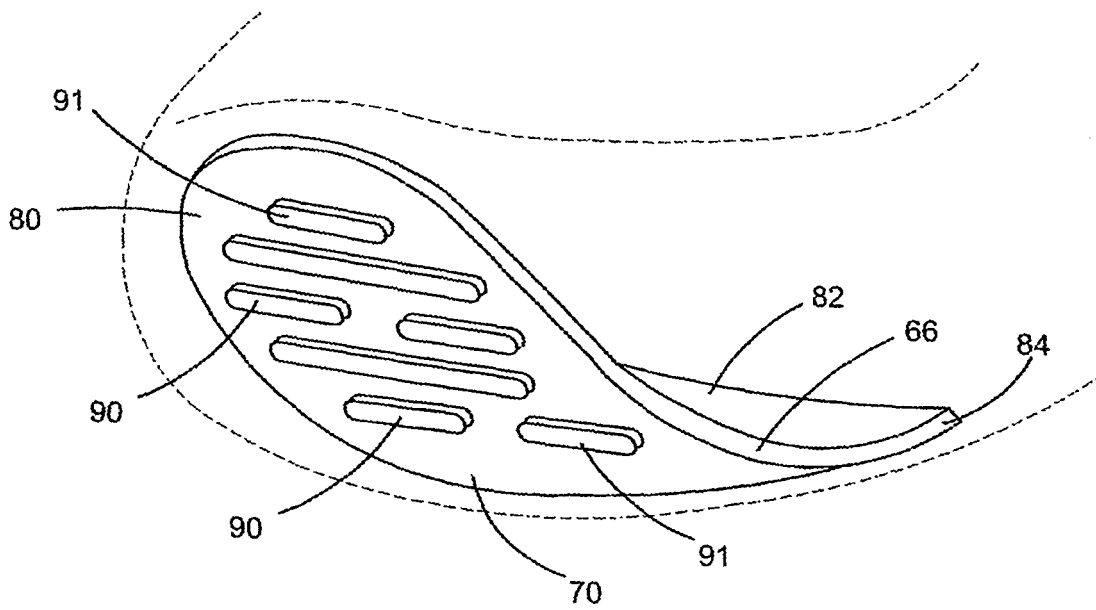

FIG. 3B

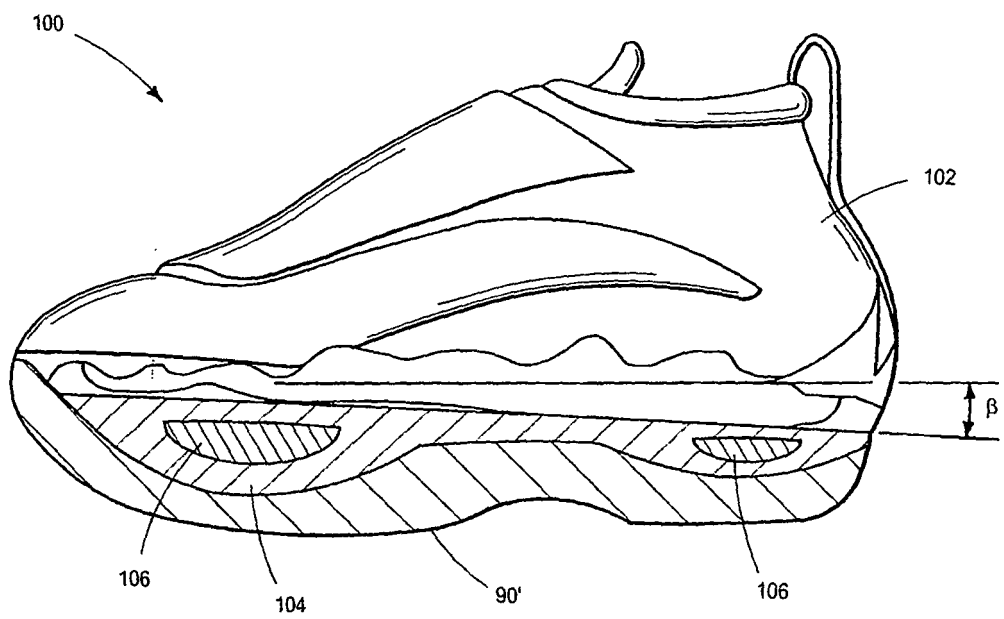

FIG. 4A

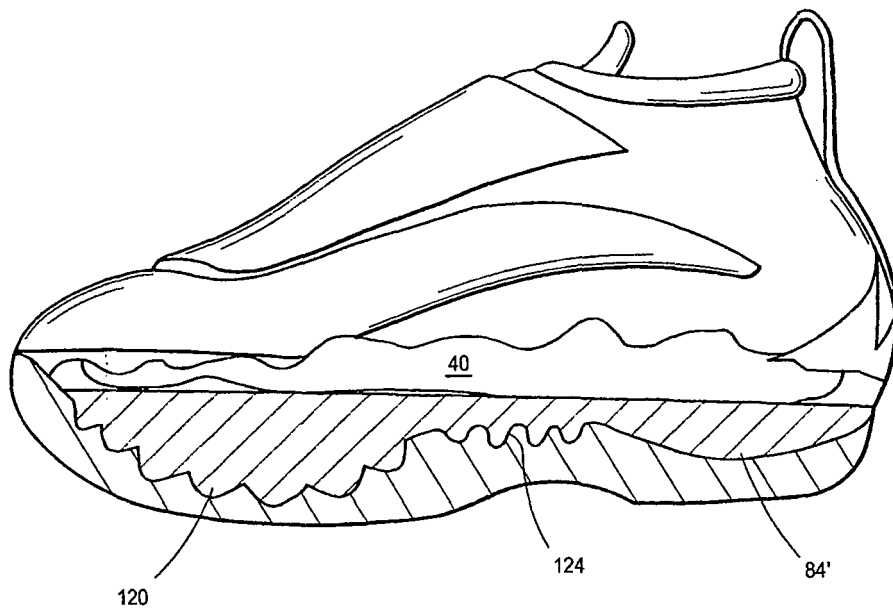

FIG. 4B

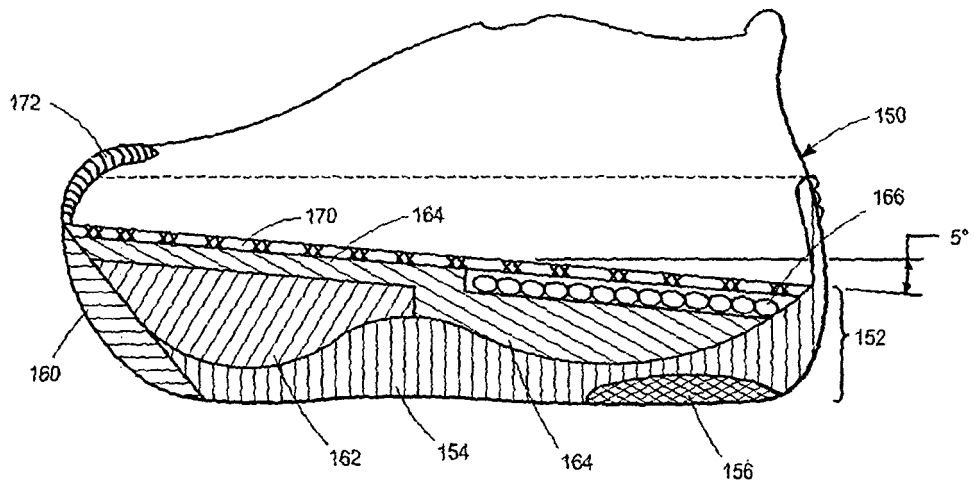

FIG. 7A

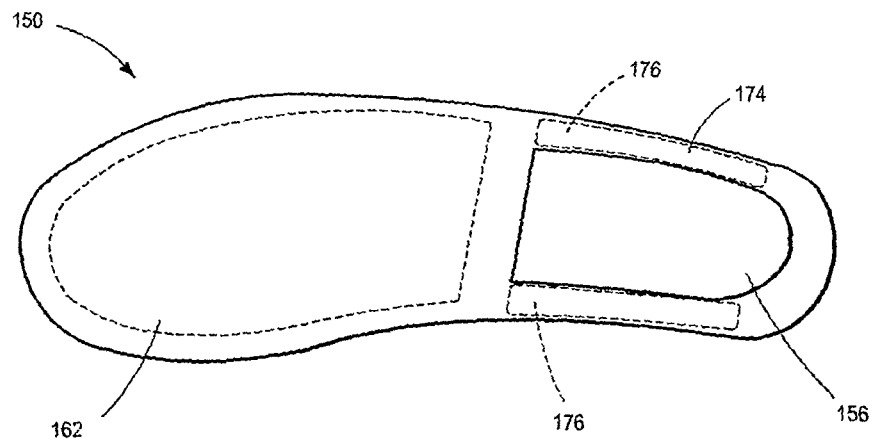

FIG. 7B

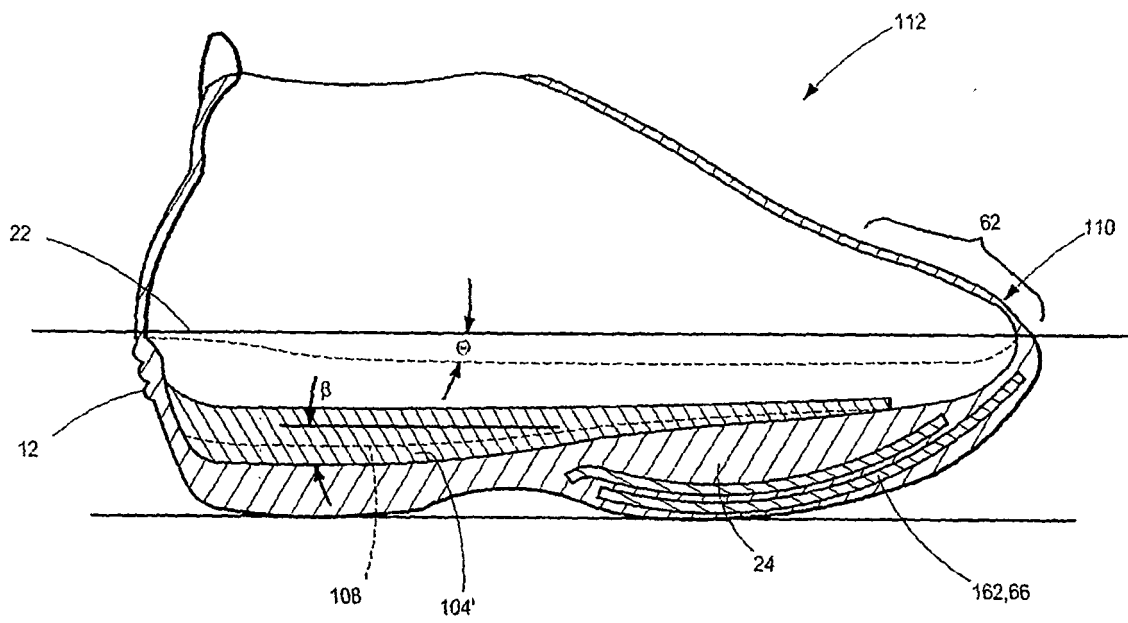

FIG. 8

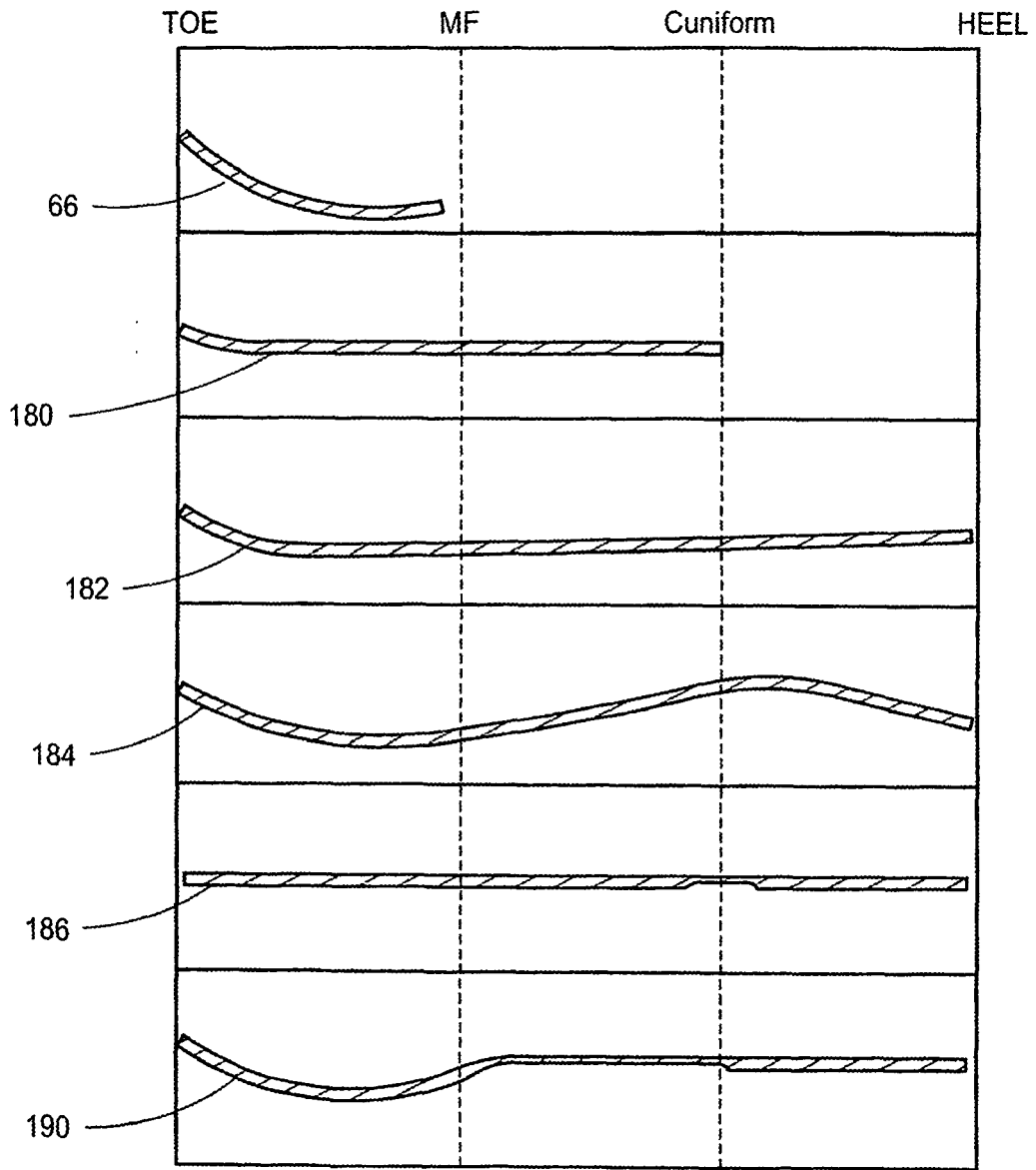

FIG. 9A

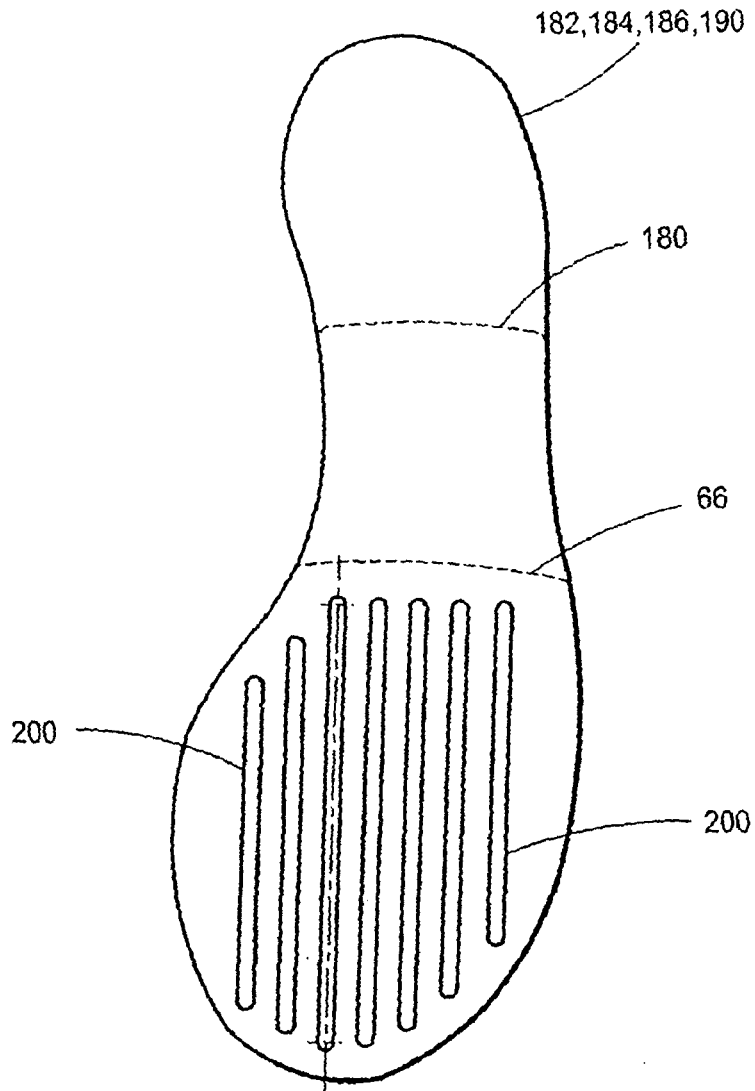
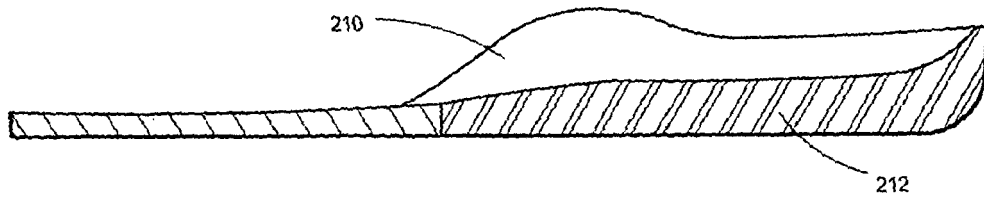
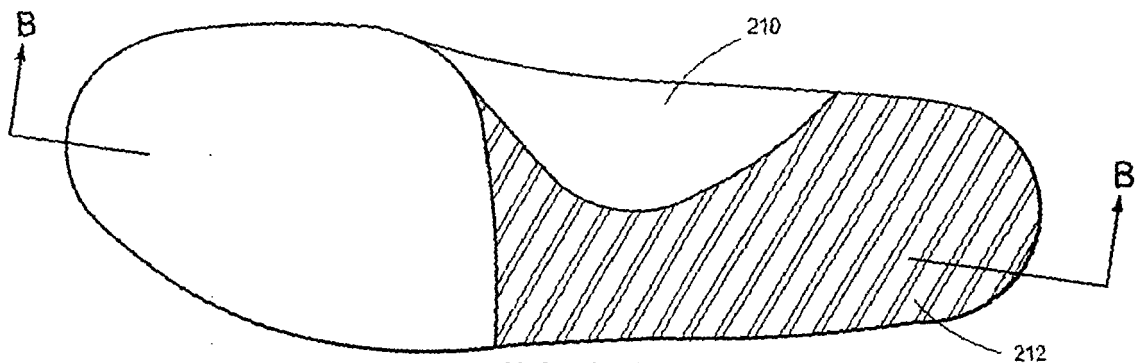

FIG. 9B



REFERENCES CITED IN THE DESCRIPTION

This list of references cited by the applicant is for the reader's convenience only. It does not form part of the European patent document. Even though great care has been taken in compiling the references, errors or omissions cannot be excluded and the EPO disclaims all liability in this regard.

Patent documents cited in the description

- US 833485 A, Whatley [0006]
- US 2002026730 A [0006]
- WO 03055343 A [0008]