

(19) World Intellectual Property Organization
International Bureau



(43) International Publication Date
28 October 2004 (28.10.2004)

PCT

(10) International Publication Number
WO 2004/093371 A2

- (51) International Patent Classification⁷: **H04L** [US/US]; 817 S. Hough Street, Barrington, IL 60010 (US). **GHOSH, Amitava** [US/US]; 3240 Indian Creek Drive, Buffalo Grove, IL 60089 (US). **KUCHIBHOTLA, Ravi** [IN/US]; 1093 Smithfield Court, Gurnee, IL 60031 (US).
- (21) International Application Number: PCT/US2004/009636
- (22) International Filing Date: 29 March 2004 (29.03.2004) (74) Agents: **CHAPA, Lawrence, J.** et al.; 600 North US Highway 45, Libertyville, IL 60048 (US).
- (25) Filing Language: English
- (26) Publication Language: English
- (30) Priority Data: 10/406,179 3 April 2003 (03.04.2003) US
- (71) Applicant (for all designated States except US): **MOTOROLA INC., A CORPORATION OF THE STATE OF DELAWARE** [US/US]; 1303 Ease Algonquin Road, Schaumburg, IL 60196 (US).
- (72) Inventors; and
- (75) Inventors/Applicants (for US only): **LOVE, Robert, T.** (84) Designated States (unless otherwise indicated, for every kind of regional protection available): ARIPO (BW, GH, ZW).

[Continued on next page]

(54) Title: METHOD AND APPARATUS FOR SCHEDULING ASYNCHRONOUS TRANSMISSIONS

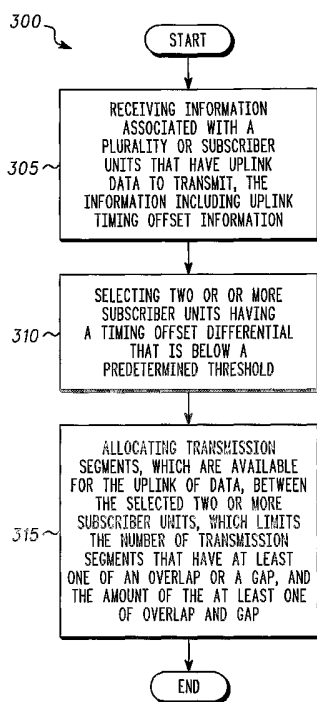

(57) Abstract: The present invention provides a method of scheduling asynchronous transmissions for a plurality of subscriber units (12). The method includes receiving (305) information associated with a plurality of subscriber units that have uplink data to transmit, the information including uplink timing offset information associated with each of the subscriber units (12). Two or more subscriber units (12) are then selected (310) from a set of subscriber units having a timing offset differential, that is below a predetermined threshold, where the timing offset differential is the difference between the timing offset of a first subscriber unit and the timing offset of a second subscriber unit further selectively offset by a multiple of the transmission segment size, which minimizes the difference. The transmission segments, which are available for the uplink of data, are then allocated (315) between the selected two or more subscriber units (12), which limits the number of transmission segments that have at least one of an overlap or a gap, and the amount of any overlap or gap, in order to minimize wasted scheduling opportunities.

WO 2004/093371 A2



GM, KE, LS, MW, MZ, SD, SL, SZ, TZ, UG, ZM, ZW), Eurasian (AM, AZ, BY, KG, KZ, MD, RU, TJ, TM), European (AT, BE, BG, CH, CY, CZ, DE, DK, EE, ES, FI, FR, GB, GR, HU, IE, IT, LU, MC, NL, PL, PT, RO, SE, SI, SK, TR), OAPI (BF, BJ, CF, CG, CI, CM, GA, GN, GQ, GW, ML, MR, NE, SN, TD, TG).

Published:

— *without international search report and to be republished upon receipt of that report*

For two-letter codes and other abbreviations, refer to the "Guidance Notes on Codes and Abbreviations" appearing at the beginning of each regular issue of the PCT Gazette.

METHOD AND APPARATUS FOR SCHEDULING ASYNCHRONOUS TRANSMISSIONS

FIELD OF THE INVENTION

5 The present invention relates generally to scheduling asynchronous transmissions and, more particularly, to scheduling asynchronous transmission, based upon timing offset information received for each of the subscriber units.

BACKGROUND OF THE INVENTION

10 Wireless communication systems are commonly put in place to provide voice and data communications. These systems often are deployed in accordance with one or more of several well known standards, which have been developed to more readily allow for the interoperability of equipment produced by different manufacturers. While earlier systems were more principally concerned with voice communications,
15 there has been a more recent effort to increasingly accommodate the transmission of data at ever increasing rates.

 Several third generation standards have emerged, which attempt to accommodate the anticipated demands for increasing data rates. At least some of these standards support synchronous communications between the system elements,
20 while at least some of the other standards support asynchronous communications. At least one example of a standard that supports synchronous communications includes CDMA2000. At least one example of a standard that supports asynchronous communications includes Wideband CDMA (W-CDMA).

 While systems supporting synchronous communications can sometimes allow
25 for reduced search times for handover searching and improved availability and reduced time for position location calculations, systems supporting synchronous communications generally require that the base stations be time synchronized. One such common method employed for synchronizing base stations includes the use of global positioning system (GPS) receivers, which are co-located with the base
30 stations, that rely upon line of sight transmissions between the base station and one or more satellites located in orbit around the earth. However, because line of sight

transmissions are not always possible for base stations that might be located within buildings or tunnels, or base stations that may be located under the ground, sometimes the time synchronization of the base stations is not always readily accommodated.

However, asynchronous transmissions are not without their own set of
5 concerns. For example, the timing of uplink transmissions in an environment supporting autonomous scheduling by the individual subscribers can be quite sporadic and/or random in nature. While traffic volume is low, the autonomous scheduling of uplink transmissions is less of a concern, because the likelihood of a collision (i.e. overlap) of data from data being simultaneously transmitted by multiple subscribers is
10 lower. Furthermore, in the event of a collision, there is spare bandwidth available to accommodate the need for any retransmissions. However, as traffic volume increases, the likelihood of data collisions (overlap) also increases. The need for any retransmissions also correspondingly increases, and the availability of spare bandwidth to support the increased amount of retransmissions correspondingly
15 diminishes. Consequently, the introduction of explicit scheduling by a scheduling controller can be beneficial.

However even with explicit scheduling, given the disparity of start and stop times of asynchronous communications and more particularly the disparity in start and stop times relative to the start and stop times of different uplink transmission
20 segments for each of the non-synchronized base stations, gaps and overlaps can still occur. Gaps correspond to periods of time where no subscriber is transmitting. Overlaps correspond to periods of time where multiple subscribers are transmitting simultaneously. Both gaps and overlaps represent inefficiencies in the usage of the available bandwidth and the management of rise over thermal (ROT), which if
25 managed more precisely can lead to more efficient usage of the available spectrum resources and a reduction in the amount of rise over thermal (ROT).

Consequently, there is a need for a method and apparatus, which more precisely schedules asynchronous communications, in a manner that minimizes and/or eliminates gaps and overlaps thus reducing the rise over thermal (ROT).

SUMMARY OF THE INVENTION

The present invention provides a method of scheduling asynchronous transmissions for a plurality of subscriber units. The method includes receiving information associated with a plurality of subscriber units that have uplink data to transmit including uplink timing offset information associated with each of the
5 subscriber units. Two or more subscriber units are then selected from a set of subscriber units having a timing offset differential, that is below a predetermined threshold, where the timing offset differential is the difference between the timing offset of a first subscriber unit and the timing offset of a second subscriber unit further
10 selectively offset by a multiple of the transmission segment size, which minimizes the difference. The transmission segments, which are available for the uplink of data, are then allocated between the selected two or more subscriber units, which limits the number of transmission segments that have at least one of an overlap or a gap, and the amount of the at least one of overlap and gap.

15 In at least one embodiment, selecting two or more subscriber units includes selecting two or more subscriber units from a list of subscriber units having the highest scheduling priority.

In at least a still further embodiment, selecting two or more subscriber units having the highest scheduling priority includes selecting the subscriber unit from the
20 list having the highest scheduling priority and selecting at least another subscriber unit from the list, which minimizes the offset differential.

In yet a still further embodiment, the power of a scheduled uplink transmission is based upon the indicated presence and the amount of any anticipated overlap.

The present invention further provides a scheduling controller for scheduling
25 asynchronous transmissions in a plurality of sub-frames of one or more channels for a plurality of subscriber units. The scheduling controller includes a receiver for receiving information associated with a plurality of subscriber units, each having uplink data to transmit, the information including uplink timing offset information. The scheduling controller further includes a controller adapted for selecting two or
30 more subscriber units having offset differentials, where the size of any one of an overlap and a gap is below a predetermined threshold, when adjacent transmission

segments of a channel are allocated to different ones of the two or more subscriber units, and for allocating the transmission segments between the two or more selected subscriber units in accordance with the selection. The scheduling controller additionally includes a transmitter for transmitting to the selected two or more
5 subscriber units the transmission segment allocations.

The present invention still further provides a subscriber unit including an uplink transmission controller for use in a subscriber unit for controlling the asynchronous transmission of uplink data. The uplink transmission controller includes a priority status module adapted for producing priority status information.
10 The subscriber unit further includes a transmitter coupled to the priority status module for transmitting priority status information to a scheduling controller, and a receiver for receiving scheduling information. The uplink transmission controller further includes an uplink transmission timing module, coupled to the transmitter and the receiver, and adapted for selectively enabling the transmitter to asynchronously
15 transmit the uplink data, in accordance with the received scheduling information.

These and other features, and advantages of this invention are evident from the following description of one or more preferred embodiments of this invention, with reference to the accompanying drawings.

20 BRIEF DESCRIPTION OF THE DRAWINGS

FIG. 1 is a wireless communication network, in accordance with at least one exemplary embodiment in which the present invention can be implemented;

FIG. 2 is a block diagram of the subscriber unit and a scheduling controller, in accordance with at least one embodiment of the present invention;

25 FIG. 3 is a more detailed block diagram of a subscriber unit, incorporating an uplink transmission controller for controlling the asynchronous transmission of uplink data;

FIG. 4 is a more detailed block diagram of a scheduling controller;

30 FIG. 5 is an exemplary timing diagram for asynchronous communication, in accordance with at least one transmission format;

FIG. 6 is an exemplary relative timing diagram for multiple subscribers, relative to a common downlink channel;

FIG. 7 is a flow diagram of a method for scheduling asynchronous transmissions for a plurality of subscriber units, in accordance with at least one
5 embodiment of the present invention;

FIG. 8 is a more detailed flow diagram for selecting subscriber units for the allocation of transmission segments;

FIG. 9 is a more detailed flow diagram for allocating transmission segments, which are available for the uplink of data; and

10 FIG. 10 is a flow diagram of a method for managing the transmission of uplink data.

DETAILED DESCRIPTION OF THE PREFERRED EMBODIMENT(S)

While the present invention is susceptible of embodiment in various forms,
15 there is shown in the drawings and will hereinafter be described presently preferred embodiments with the understanding that the present disclosure is to be considered an exemplification of the invention and is not intended to limit the invention to the specific embodiments illustrated.

FIG. 1 illustrates at least one example of an asynchronous wireless
20 communication network 10 in which it would be suitable to incorporate the present invention. Examples of asynchronous wireless communication networks include networks, which conform to several well known standards including Global System for Mobile Communications (GSM) and Wide band CDMA (WCDMA).

The communication network 10 illustrates a pair of subscriber units 12, which
25 communicate with at least one of a pair of base stations 14. In the same or alternative embodiments, a subscriber unit can be sometimes alternatively referred to as User Equipment (UE). In the same or alternative embodiments, a base station can be sometimes alternatively referred to as node-B or Base Transceiver Station (BTS).

In the illustrated embodiment, the base stations 14 are each coupled to a
30 corresponding one of a plurality of radio network controller 15. In turn, the radio network controllers 15 are each coupled to network 16, which can include wired

elements as well as other wireless elements. The wired elements of network 16 can include all or portions of a public switched telephone network (PSTN). The other wireless elements can include other types of wireless communications such as paging systems, radio broadcast systems, and other cellular systems including cellular systems incorporating synchronous communications. The network 10 additionally includes one or more scheduling controllers 18. In at least one embodiment, the scheduling controllers 18 are integrated as part of and/or are coupled to one or more of the base stations 14. While the illustrated embodiment includes a scheduling controller, which is integrated with a base station, at least one embodiment is envisioned where the scheduling controller 14 could be a separate stand alone device, that separately communicates within the network. Still further, the scheduling controller could alternatively be partially or entirely integrated as part of a radio network controller 15. While a particular network configuration is illustrated, one skilled in the art will readily appreciate that alternative network configurations, including alternative coupling arrangements between the various network elements are possible without departing from the teachings of the present invention.

FIG. 2 illustrates a block diagram of each of a subscriber unit 12 and a scheduling controller 18. As previously noted, the scheduling controller 18 can be incorporated as part of a base station 14. Incorporation of the scheduling controller 18 as part of a base station 14, enables the scheduling controller 18 to share transmitter 20 and receiver 22 resources with the other wireless communication capabilities of the base station. Both the transmitter 20 and the receiver 22 are each coupled to an antenna 24, which is used to receive and transmit wireless signals. Both the transmitter 20 and the receiver 22 are additionally coupled to controller 25, which facilitates the scheduling of asynchronous communications. The controller 25 can additionally be coupled to a network interface 29, which facilitates communication between the scheduling controller 18 and network resources.

In at least one embodiment, the controller includes a processor 26 and a storage unit 28. The processor 26 can include one or more microprocessors. The storage unit 28 can include one or more volatile or non-volatile, fixed or removable storage devices for storing programming instructions to be executed by the processor

26 and any corresponding program data. In some instances, one or more of the microprocessors can include one or more integrated storage elements, which can be used to store programming instructions for execution by the microprocessor and/or other data. For example, a microprocessor may have an embedded Random Access
5 Memory (RAM) or Read Only Memory (ROM). Additionally or alternatively, the controller can incorporate logic circuitry, which manages the operation of the scheduling controller, including sequential state machines and other logic elements.

More specifically, the transmitter 20 and receiver 22 each enable the scheduling controller to communicate with a plurality of remote subscriber units 12
10 for the purpose of receiving information corresponding to the current operating condition of each of the relevant subscriber units 12, and for conveying transmission assignments including, possibly, information relevant to the amount of any anticipated overlap and gap.

In the illustrated embodiment, the subscriber unit 12 similarly includes a
15 transmitter 30 and a receiver 32, coupled to an antenna 33, for use in communicating information between the subscriber unit 12 and the scheduling controller 18. Both the transmitter 30 and the receiver 32 are additionally coupled to an uplink transmission controller 34, which manages the control of at least some of the uplink transmissions including controlling the transmission timing, based upon the transmission segments
20 allocated to the subscriber unit 12 by the scheduling controller 18, and controlling the data rates of the information transmitted, based upon the amount of any anticipated overlap and gap.

Similar to the controller 25 of the scheduling controller 18, the uplink transmission controller 34 of the subscriber unit 12 can include a processor and
25 corresponding storage unit, as well as additionally or alternatively incorporating logic circuitry including sequential state machines and other logic elements.

A more detailed block diagram of the subscriber unit 12 is illustrated in FIG. 3. In FIG. 3, the uplink transmission controller 34 includes a plurality of modules. Each module can correspond to a set of programming instructions organized into a set
30 of one or more program routines, additionally or alternatively, each module can correspond to a set of interconnected circuit elements for accomplishing a specific

task. In some instances, the modules may share all or some of the program routines, data elements, and/or circuit elements.

In the illustrated embodiment, the uplink transmission controller 34 of the subscriber unit 12 includes a priority status module 36 and a transmission control
5 module 38, which has a transmission timing module 40 and a data rate determination module 42. The priority status module 36 is coupled to the transmitter 30, and produces and manages the subscriber unit's priority status information. This information can include one or more of the delay since the subscriber unit 12 was last
10 scheduled to upload data, the current maximum achievable data rate of the subscriber unit 12, which can be a function of the current available power margin, the amount of data in the queue ready to be transmitted, relative to the queue size, and a quality of service status. Other types of information may also be suitable. All or some of this information is supplied to the scheduling controller 18 for purposes of determining the allocation of transmission segments.

15 The transmission control module 38 is coupled to both the transmitter 30 and the receiver 32, in which the included transmission timing module 40 and data rate determination module 42, are also each coupled to the transmitter 30 and the receiver 32. The transmission timing module 40 receives transmission segment assignments, based upon the transmission segment allocations made by the corresponding
20 scheduling controller 18, and provides control signals to the transmitter 30 for managing the timing of uplink transmissions. The data rate determination module 42 receives information concerning any anticipated overlap from the scheduling controller 18 during a transmission segment in which the subscriber unit 12 is assigned to transmit, and based upon the amount of any overlap, the data rate
25 determination module 42 will produce control signals for adjusting the data rate of the uplink transmission.

By decreasing the data rate, and accommodating the insertion of additional error correction bits, the uplink transmission has a better chance of successfully receiving and decoding information despite the presence of a known interference
30 source. Preferably, the amount of any overlap can be minimized to minimize the need, if any, to reduce the data rate, based upon overlap, and the likelihood that the

transmission segment will need to be retransmitted as a result of an inability to accurately decode the transmitted segment.

FIG. 4 illustrates a more detailed block diagram of the scheduling controller 18. Similar to the uplink transmission controller 34 of the subscriber unit 12, the controller 25 of the scheduling controller 18 includes a plurality of modules, which
5 similar to the modules of the uplink transmission controller 34 can correspond to one or more sets or programming routines and/or a set of circuit elements, which can be selectively shared between the different modules.

In the illustrated embodiment, the controller 25 includes an offset differential
10 determination module 44 for receiving uplink timing offset information for each of the subscriber units 12 and determining corresponding offset differentials. In at least one embodiment, the uplink timing offset information is provided to the scheduling controller 18 by the radio network controller 15, via the network interface 29. However, in one or more alternative embodiments, the timing offsets for each of the
15 subscriber units 12 is determined directly by the scheduling controller 18, from the information received from the subscriber unit 12, via the receiver 22. Where the timing offsets are determined directly, the scheduling controller may not include a network interface 29.

The determined offset differentials are received by a subscriber unit selection
20 module 46, which prioritizes and selects the subscriber units, based upon the received offset differentials and possibly other priority information received from the subscriber units 12.

The selected subscriber units 12 are then supplied to the allocation module 48,
coupled to the offset determination module 44, the subscriber unit selection module
25 46 and the transmitter 20, which allocates the transmission segments among the one or more of the selected subscriber units 12. The transmission segment allocations are then transmitted to the respective subscriber units 12. In at least a further
embodiment, the allocation module 48 additionally includes an overlap/gap estimation
module 50, which estimates any anticipated amount of overlap and gap. The amount
30 of any anticipated overlap and gap is then supplied to the respective subscriber units

12, with the transmission segment allocation information. As noted previously, the amount of any anticipated overlap and gap can be used to adjust the uplink data rate.

FIG. 5 illustrates an exemplary timing diagram 100 for the transmissions of a single subscriber using asynchronous communication, in accordance with at least one transmission format. The timing diagram 100 is consistent with the timing used in connection with Wideband CDMA (W-CDMA). Because the standard expressly provides for the use of asynchronous communication, the transmission start times relative to one another will generally not coincide. As part of managing the various start times, the base station defines a frame plus chip offset for each of the subscribers. When a subscriber is handed off to another base station, the new base station establishes its frame plus chip offset for the subscriber based on information received from the radio network controller such that the subscriber receives the downlink transmission from the new base station within its slew buffer. A new frame plus chip offset is necessary as a result of being handed off to a new base station, because the different base stations are not time synchronized, relative to one another. Consequently, a frame plus chip offset for a subscriber unit relative to one base station will not be the same relative to another base station.

For two subscribers, whose start times generally do not coincide, if adjacent transmission segments of the same uplink data channel are assigned to the two subscribers, there will most likely be either a gap or an overlap proximate the transmission segment transition point. This is because the stop time of the earlier transmitted transmission segment from the first subscriber will not coincide with the start time of the later transmitted transmission segment from the second subscriber. If a gap occurs, than no data will be transmitted during the period of time corresponding to the gap. If an overlap occurs, than during the overlap both subscriber units are transmitting portions of the corresponding transmission segments, simultaneously. During this time each transmitted signal potentially interferes with the other transmitted signal during the duration in which they are being simultaneously transmitted.

At least one embodiment attempts to minimize gaps and/or overlaps by selecting subscriber units for assignment to transmit during adjacent transmission

segments, which have minimal offset differentials, or whose offset differential coincides with as close to an even multiple of the transmission segment size. In so doing, the amount of gap and/or overlap is minimized.

In FIG. 5, the frame plus chip offset is referenced relative to the reception of a common downlink channel (P_CCCH). The transmission time difference between the start of the transmission of the downlink dedicated physical channel and the common downlink channel defines the frame plus chip offset. In the illustrated embodiment, prior to the transmission of data on an uplink data channel, the mobile subscriber receives a downlink scheduling assignment on a scheduling assignment channel. The scheduling information for each transmission segment can be transmitted, separately, or alternatively the scheduling information for multiple transmission segments can be encoded and transmitted together.

The start time of the transmission of data on an uplink data channel for a subscriber relative to the corresponding downlink dedicated physical channel is a time period that is delayed by an amount referred to as T_0 . In at least one embodiment, T_0 is 1024 chips. In the illustrated embodiment, the rate at which the subscriber unit is transmitting information to the base station is conveyed to the base station as part of a transport format rate indicator channel. The rate information is transmitted sufficiently in advance of the corresponding transmission segment, so that the base station can adapt as necessary to accommodate the indicated rate.

In the illustrated embodiment, time is broken up into 10ms segments. Each 10ms period corresponds to a frame. Each frame is divided into five 2ms sub-frames. Each sub-frame can further be broken down into three slots. Each 10ms frame includes 38,400 chips. In the illustrated embodiment, each transmission segment corresponds to each of the 2ms sub-frames. However, other transmission segment sizes can be alternatively defined without departing from the teachings of the present invention.

For purposes of timing, a 10ms segment is broken down into 75 different 512 chip segments, numbered 0-74. The 75 different 512 chip segments corresponds to the granularity with which the frame plus chip offset is defined. This insures that the timing of the subscriber unit is never more than 256 chips away from the boundaries

of one of the 512 chip segments. In order to accommodate this level of granularity, in terms of timing, a slew buffer of 256 chips corresponding to a de-skewer span is maintained (148 chips for base station offset +108 chips for delay spread). The subscriber unit will pay attention to transmissions that fall within the de-skewer span for making adjustments to the transmitter power level. While the present embodiment has been described using a particular timing granularity and slew buffer size, one skilled in the art will readily recognize that the present invention could be adapted to accommodate finer or coarser granularity in terms of offset timing, as well as accommodate different slew buffer sizes without departing from the teachings of the present invention.

After a data segment is received, a positive or negative acknowledgement is produced by the receiving base station and transmitted to the subscriber unit, whose start time corresponds to the propagation delay of the uplink data channel and the delay associated with processing the received data. The subscriber unit, when scheduled again, can then transmit a new packet or re-transmit the old packet depending on whether it decoded the acknowledgement as positive or negative.

FIG. 6 illustrates a timing diagram 200 illustrating an example of the timing relationship between three subscriber units. As noted above, the frame plus chip offset is measured relative to a common timing reference. In the illustrated embodiment, the common timing reference is the common downlink channel (P_CCPCH).

FIG. 6 further illustrates a timing offset differential, which corresponds to the difference between the start time of a transmission segment for a first subscriber unit and the start time of a transmission segment for a second subscriber unit, that is transmitted closest in time to the start time of the transmission segment of the first subscriber unit.

An exemplary overlap/gap is illustrated relative to each of the subscriber pairs. While the timing offset difference between subscriber 1 and subscriber 2 is identified as an overlap, the timing differential would only produce an overlap if subscriber 2 transmitted in the adjacent segment after the preceding transmission segment transmitted by subscriber 1. If the transmission segment transmitted by subscriber 2

preceded the adjacent transmission segment transmitted by subscriber 1, than a corresponding gap would occur. In the present example, among the three subscribers, subscriber 1 and subscriber 3 have the smallest timing differential. Consequently, subscriber 3 could transmit a transmission segment in an adjacent transmission
5 segment after subscriber 1 and minimize the relative amount of overlap.

Furthermore, if subscriber 1 was assigned to transmit transmission segments on sub-frames 1 through 3 (CH1-CH3), and if the next adjacent transmission segment was to be assigned to subscriber 3, then subscriber 3 would be instructed to transmit the transmission segments beginning with sub-frame 2 (CH2), which would coincide
10 with sub-frame 4 (CH4) of subscriber 1. As noted above, the subscriber units may accommodate any overlap by adjusting transmission rates for the particular segments in which overlap is anticipated to occur.

In selecting the multiple subscribers that will be assigned to transmit using adjacent transmission segments an attempt is made to minimize any resulting overlap.
15 However the decision to allocate a transmission segment can additionally take into account priority information. In at least one embodiment, the first subscriber unit selected for allocation of transmission segments will be the subscriber unit having the highest priority. A second subscriber unit can then be selected for the allocation of subsequent transmission segments, which minimizes the timing offset differential
20 relative to first selected subscriber unit, from among the other subscriber units that have data to be uploaded. Alternatively, the second subscriber can be selected from a more limited subset of the other subscriber units, which includes the subscriber units that have the highest priorities.

In at least a still further alternative embodiment, the two or more subscriber
25 units for allocation of transmission segments are the subscriber units having the smallest timing offset differential, which are both included in a subset of the subscriber units having the highest priorities.

The priority of a subscriber unit can be affected by the delay since the subscriber unit last transmitted a timing segment. The priority of a subscriber unit can
30 also be affected by amount of data in the queue, which in at least some instances will take into consideration the amount of data in the queue relative to the queue size. The

priority status of a subscriber unit may also take into consideration the power level information, power margin information, and the requested/required quality of service. In at least one embodiment, there is generally a goal to minimize wasted scheduling opportunities.

5 FIG. 7 illustrates a flow diagram of a method 300 for scheduling asynchronous transmissions for a plurality of subscriber units, in accordance with at least one embodiment of the present invention. Generally, the flow diagrams, illustrated in FIGS. 7-10, can be implemented in circuitry or as prestored sets of programming instructions, which can be executed on a microprocessor.

10 The method 300 includes receiving information associated with a plurality of subscriber units that have uplink data to transmit, the information including uplink timing offset information 305. Two or more subscriber units are then selected 310, which have a timing offset differential that is below a predetermined threshold. Transmission segments, which are available for the uplink of data, are then allocated
15 between the selected two or more subscriber units, which limits the number of transmission segments that have at least one of an overlap or a gap, and the amount of any overlap and gap 315.

 Generally, the predetermined threshold corresponds to a preselected limit defining a maximum allowable timing offset differential. In some instances the
20 selected value of predetermined threshold can be a function of other conditions or elements. For example, the predetermined threshold can be a function of the available noise margin. In other instances, the predetermined threshold might be determined experimentally, relative to one or more sets of expected operating conditions. In at least one embodiment, the predetermined threshold is generally smaller than the
25 transmission segment size.

 In at least one embodiment, the scheduling of asynchronous transmissions is performed by a scheduling controller, which can be incorporated as part of a cellular base station.

 FIG. 8 is a more detailed flow diagram for selecting subscriber units for the
30 allocation of transmission segments 310, in accordance with at least one embodiment. The selection of subscriber units 310 includes ordering the subscriber units based

upon scheduling priority 320. The subscriber units are then selected from the list of subscriber units having the highest scheduling priorities 325. Subscriber units from the subset are then selected, which minimizes wasted scheduling opportunities, maximizes fairness, and/or minimizes noise rise variations 330.

5 FIG. 9 is a more detailed flow diagram for allocating transmission segments 315, which are available for the uplink of data, in accordance with at least one embodiment. The allocation of transmission segments 315 includes assigning as the first selected subscriber unit, the subscriber unit having the earliest frame timing 335. A number of transmission segments to be allocated are then identified and scheduled
10 340, using noise rise budget, signal-to-noise margin, and the traffic volume report for the presently assigned subscriber unit. A determination is then made 345, whether any of the transmission segments have any remaining noise rise budget. If there is no remaining noise rise budget, then the scheduling priority information is updated 350. Otherwise, the next subscriber unit is assigned 355.

15 A determination is then made 360, as to whether there is any remaining noise rise budget in the last scheduled transmission segment. If there is remaining noise rise budget in the last scheduled transmission segment, then the transmission segment, which overlaps or is closest to the transmission segment last scheduled is used for allocation 370. If there is not any remaining noise rise budget in the last scheduled
20 transmission segment, then the transmission segment, which is closest to and does not overlap the last scheduled transmission segment, is used for allocation 365. The identification and scheduling of the number of transmission segments to be allocated 340 is repeated, until none of the transmission segments have any remaining noise rise budget.

25 FIG. 10 is a flow diagram of a method 400 for managing the transmission of uplink data, in accordance with at least one embodiment. Generally, the method for managing the transmission of uplink data is performed by one or more of the subscriber units. The method 400 includes producing and maintaining priority status information 405. The priority status information is then transmitted 410 to the
30 scheduling controller. Scheduling information including the amount of any anticipated overlap is then received 415 from the scheduling controller.

The data rate is determined and adjusted 420 for accommodating any anticipated overlap in any of the corresponding transmission segments. The uplink data is then transmitted 425, in accordance with the received scheduling information.

5 While the preferred embodiments of the invention have been illustrated and described, it is to be understood that the invention is not so limited. Numerous modifications, changes, variations, substitutions and equivalents will occur to those skilled in the art without departing from the present invention as defined by the appended claims. For example, while the present examples largely are directed to over the air asynchronous data communications, the present invention may similarly
10 be beneficial to asynchronous data communications that are generally confined to physical point to point connections. Such physical point to point connections can include wired connections, which conduct electrical signals, optical fiber, which conduct optical signals, or any other suitable form for facilitating the transmission of information. Still further the present embodiment has largely been directed to
15 asynchronous type communication, however, the teachings of the present invention may also be beneficial to the scheduling of synchronous data transmission from multiple sources, where there is a possibility that the start and stop times of the data transmissions from the multiple sources can cause significant gaps and/or overlaps, if the transmissions are not suitably managed.

20

WHAT IS CLAIMED IS:

1. A method for scheduling asynchronous transmissions for a plurality of subscriber units, the method comprising:
 - receiving information associated with a plurality of subscriber units that have
 - 5 uplink data to transmit, the information including uplink timing offset information associated with each of the subscriber units;
 - selecting two or more subscriber units from a set of subscriber units having a timing offset differential, that is below a predetermined threshold, where the timing offset differential is the difference between the timing offset of a first subscriber unit
 - 10 and the timing offset of a second subscriber unit further selectively offset by a multiple of the transmission segment size, which minimizes the difference; and
 - allocating transmission segments, which are available for the uplink of data, between the selected two or more subscriber units, which limits the number of transmission segments that have at least one of an overlap or a gap, and the amount of
 - 15 the at least one of overlap and gap.
2. A method in accordance with claim 1 wherein the uplink timing offset information includes a frame offset and a chip offset.
- 20 3. A method in accordance with claim 1 wherein selecting two or more subscriber units includes selecting two or more subscriber units from a list of subscriber units having the highest scheduling priorities.
4. A method in accordance with claim 3 wherein the scheduling priority is based
- 25 upon the delay since the subscriber unit was last scheduled to upload data.
5. A method in accordance with claim 3 wherein the scheduling priority is based upon the current maximum achievable data rate of the subscriber unit.

6. A method in accordance with claim 5 wherein the maximum achievable data rate of the subscriber unit is determined by the current available power margin of the subscriber unit.
- 5 7. A method in accordance with claim 6 wherein the current available power margin of the subscriber unit is the difference between the maximum allowable power level of the subscriber unit and the power level of one or more reference channels.
8. A method in accordance with claim 7 wherein the reference channel is a
10 dedicated physical control channel.
9. A method in accordance with claim 7 wherein the reference channel is a pilot channel.
- 15 10. A method in accordance with claim 6 wherein the current available power margin of the subscriber unit is the difference between the maximum allowable power level of a data channel and the power level of one or more reference channels.
11. A method in accordance with claim 3 wherein the scheduling priority is based
20 upon the amount of data ready to be uploaded.
12. A method in accordance with claim 11 wherein the amount of data ready to be uploaded corresponds to the amount of the data in the queue.
- 25 13. A method in accordance with claim 3 wherein selecting two or more subscriber units from a list of subscriber units having the highest scheduling priorities includes selecting the subscriber unit from the list having the highest scheduling priority and selecting at least another subscriber unit from the list, which minimizes the offset differential.

30

14. A method in accordance with claim 13 wherein prior to selecting at least another subscriber unit from the list, verifying that there is sufficient noise margin, in any unassigned transmission segments or any transmission segments in which overlap would occur, to support the selection of the additional subscriber unit from the list for
5 transmitting uplink data on at least one of the unassigned transmission segments.

15. A method in accordance with claim 14 wherein the noise margin includes an interference rise over thermal noise margin.

10 16. A method in accordance with claim 14 wherein the verified available noise margin is used to determine a maximum uplink data rate.

17. A method in accordance with claim 3 wherein the scheduling priority is based upon the signal-to-noise ratio of a signal received from the subscriber unit.

15

18. A method in accordance with claim 3 wherein the scheduling priority is based upon a quality of service status received from the subscriber unit.

19. A method in accordance with claim 1 wherein allocating transmission
20 segments includes transmitting on a downlink control channel to the subscriber units the transmission segment allocations.

20. A method in accordance with claim 19, wherein the transmission segment allocations transmitted on a downlink control channel includes an indication of the
25 presence of anticipated overlap on one or more of the transmission segments.

21. A method in accordance with claim 20 wherein the transmission segment allocations transmitted on a downlink control channel includes an indication of the amount of any anticipated overlap on one or more of the transmission segments.

30

22. A method in accordance with claim 21 further comprising adjusting the data rate of the uplink transmission during the assigned transmission segment based upon the indicated presence and amount of any anticipated overlap.
- 5 23. A method in accordance with claim 21 further comprising adjusting the power level of the uplink transmission during the assigned transmission segment based upon the indicated presence and amount of any anticipated overlap.
- 10 24. A method in accordance with claim 19, wherein the transmission segment allocations are made by a cellular base station, and the subscriber units include cellular radio telephones.
- 15 25. A scheduling controller for scheduling asynchronous transmissions in a plurality of sub-frames of one or more channels for a plurality of subscriber units comprising:
a receiver for receiving information associated with a plurality of subscriber units, each having uplink data to transmit, the information including uplink timing offset information;
a controller adapted for selecting two or more subscriber units having offset
20 differentials, where the size of any one of an overlap and a gap is below a predetermined threshold, when adjacent transmission segments of a channel are allocated to different ones of the two or more subscriber units, and for allocating the transmission segments between the two or more selected subscriber units in accordance with the selection; and
25 a transmitter for transmitting to the selected two or more subscriber units the transmission segment allocations.
- 30 26. A scheduling controller in accordance with claim 25 wherein the received information associated with the plurality of subscriber units additionally includes one or more of power level information, power margin information, quality of service information, and queue size.

27. A scheduling controller in accordance with claim 25 wherein at least the first one of the two or more selected subscriber units is based upon a determined scheduling priority.
- 5
28. A scheduling controller in accordance with claim 27 wherein the first one of the two or more selected subscriber units is the subscriber unit having the highest scheduling priority.
- 10
29. A scheduling controller in accordance with claim 25 wherein the two or more selected subscriber units are selected from a list of a predetermined number of subscriber units having the highest scheduling priorities.
- 15
30. A scheduling controller in accordance with claim 25 wherein the transmitted transmission segment allocations includes at least one of the presence and amount of at least one of gap and overlap.
31. A scheduling controller in accordance with claim 25 wherein the scheduling controller is incorporated as part of a cellular base station.
- 20
32. A subscriber unit comprising:
an uplink transmission controller for controlling the asynchronous transmission of uplink data including a priority status module adapted for producing priority status information;
25 a transmitter, coupled to the priority status module of the uplink transmission controller, for transmitting priority status information to a scheduling controller; and
a receiver for receiving scheduling information; and
wherein the uplink transmission controller further includes an uplink transmission timing module, coupled to the transmitter and receiver, adapted for
30 selectively enabling the transmitter to asynchronously transmit the uplink data, in accordance with the received scheduling information.

33. A subscriber unit in accordance with claim 32 wherein the priority status information includes one or more of quality of service information, and queue information.

5

34. A subscriber unit in accordance with claim 33 wherein the queue information includes one or more of the amount of data in the queue ready to be uploaded and the queue size.

10 35. A subscriber unit in accordance with claim 32 wherein the transmitter additionally transmits a transmit format rate indicator.

36. A subscriber unit in accordance with claim 32 wherein the transmitter additionally transmits any hybrid automatic repeat requests.

15

37. A subscriber unit in accordance with claim 32 wherein the transmitter additionally transmits the available power margin.

38. A subscriber unit in accordance with claim 32 wherein the decoded scheduling
20 information includes any anticipated transmission overlap information relative to each transmission segment.

39. A subscriber unit in accordance with claim 38 wherein the uplink transmission
25 controller additionally includes a data rate determination module, coupled to the transmitter and the receiver, which is adapted to control the transmission data rate for each transmission segment, in response to any anticipated transmission overlap information.

40. A subscriber unit in accordance with claim 32 where the subscriber unit is a
30 cellular radio telephone.

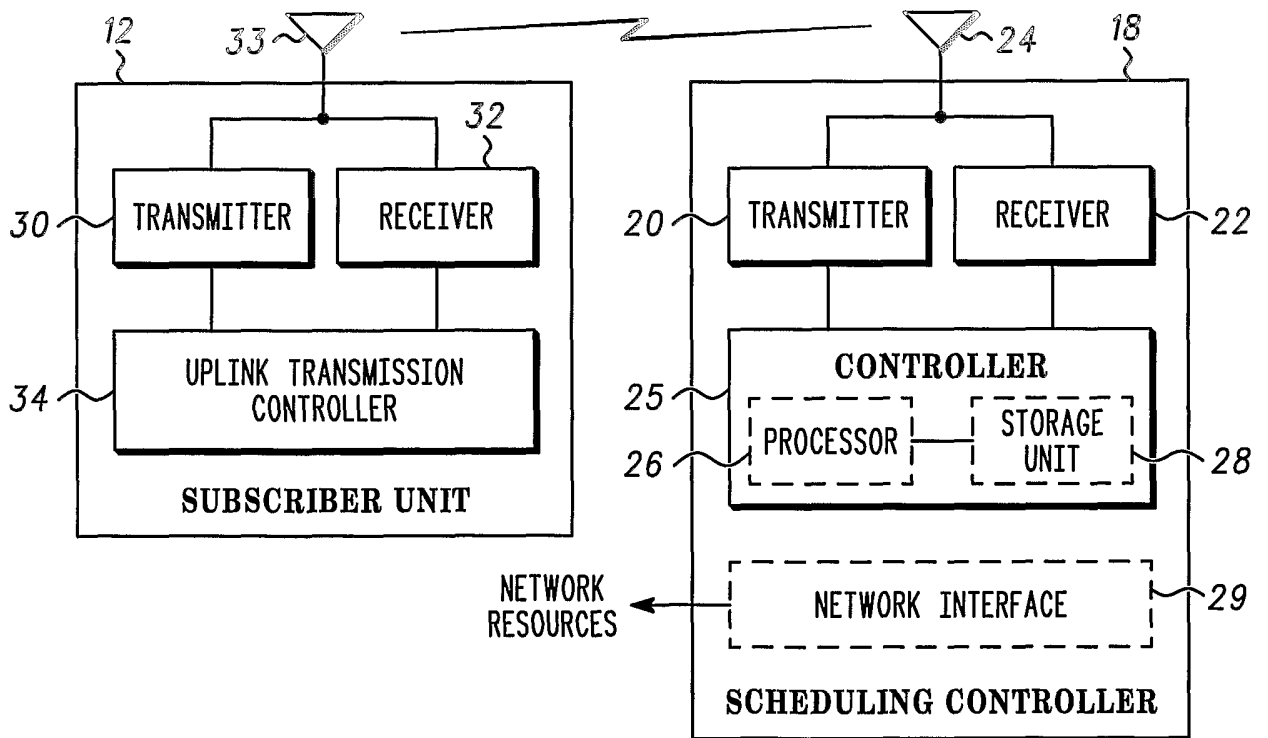
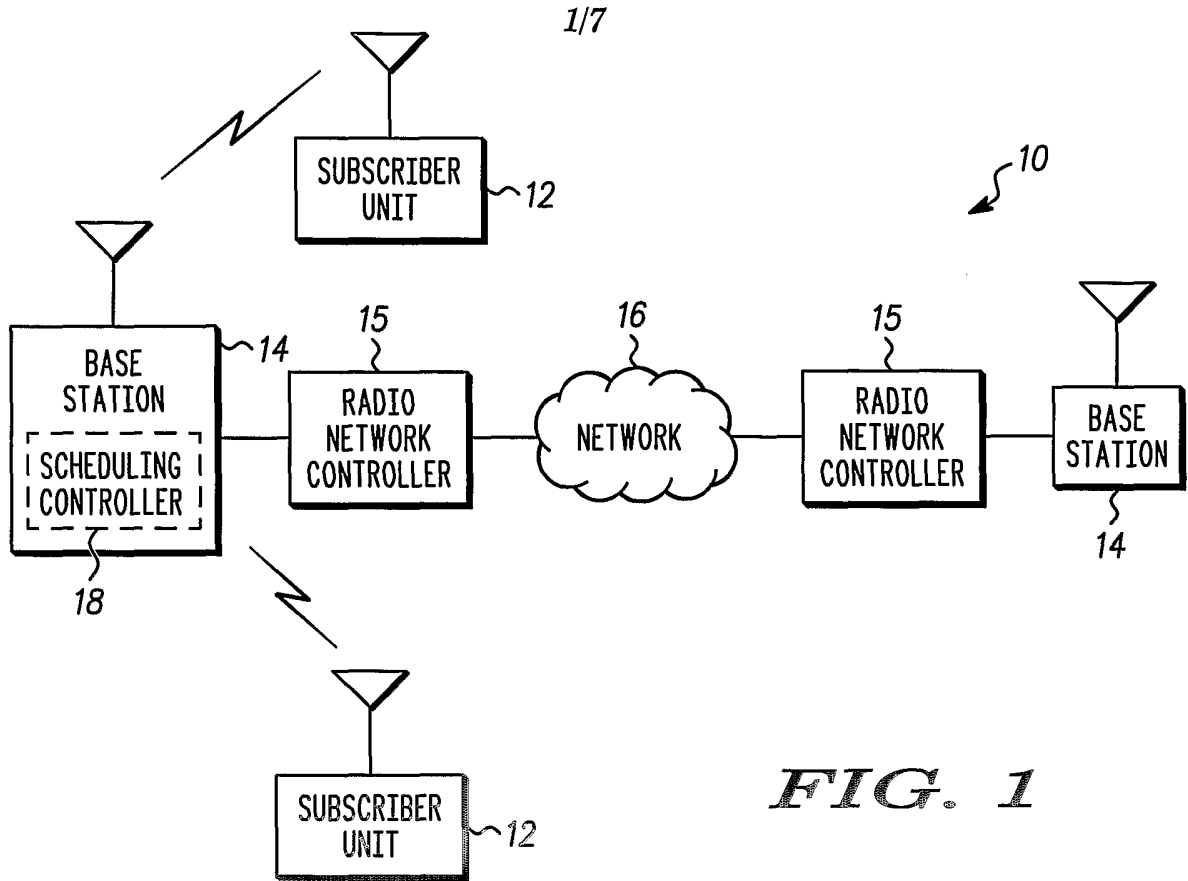

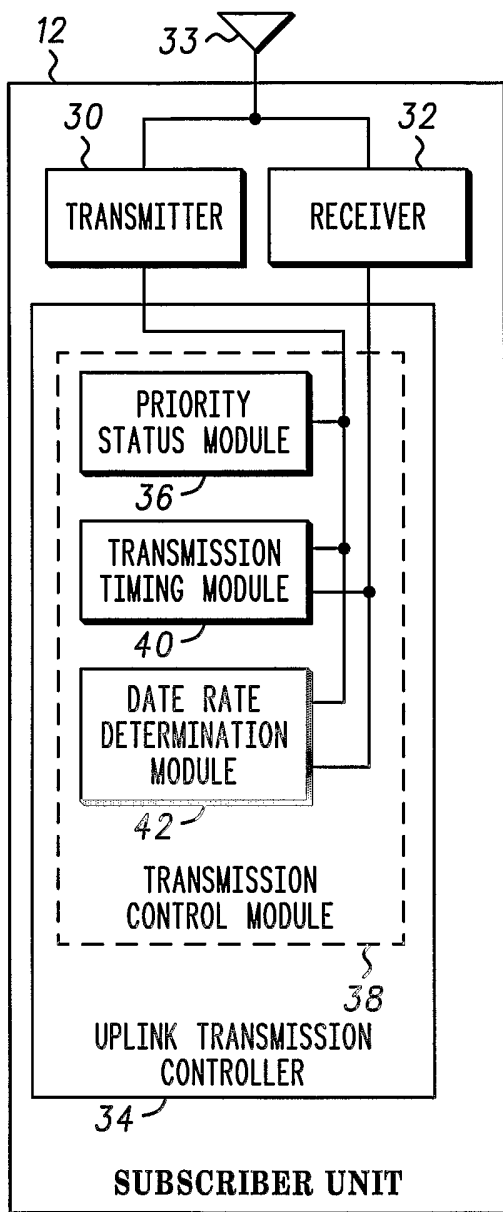

FIG. 3

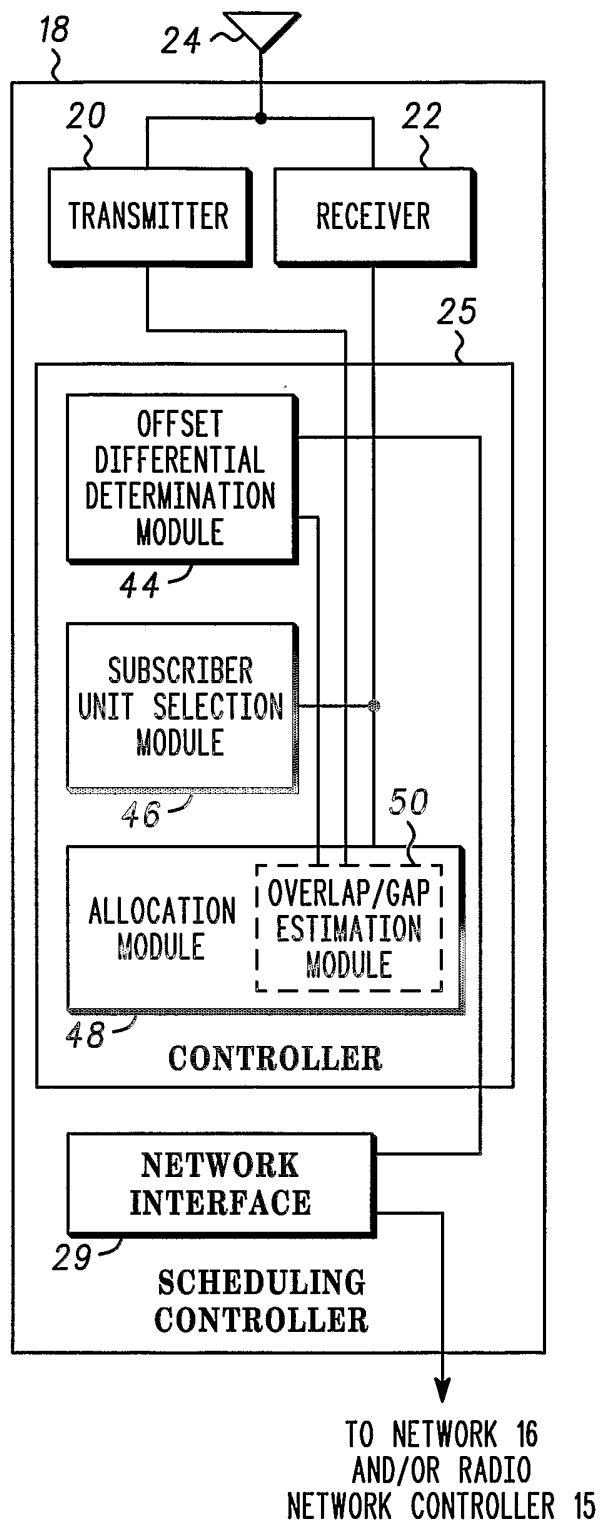

FIG. 4

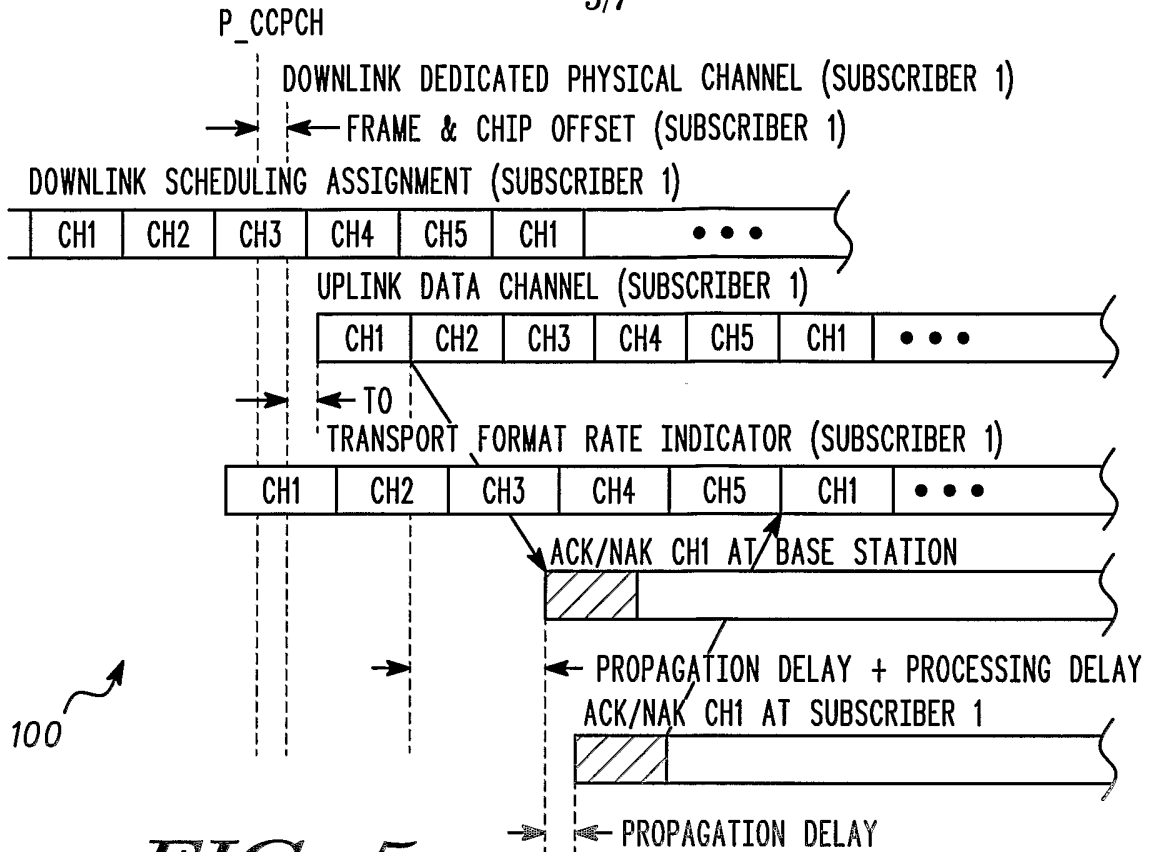

FIG. 5

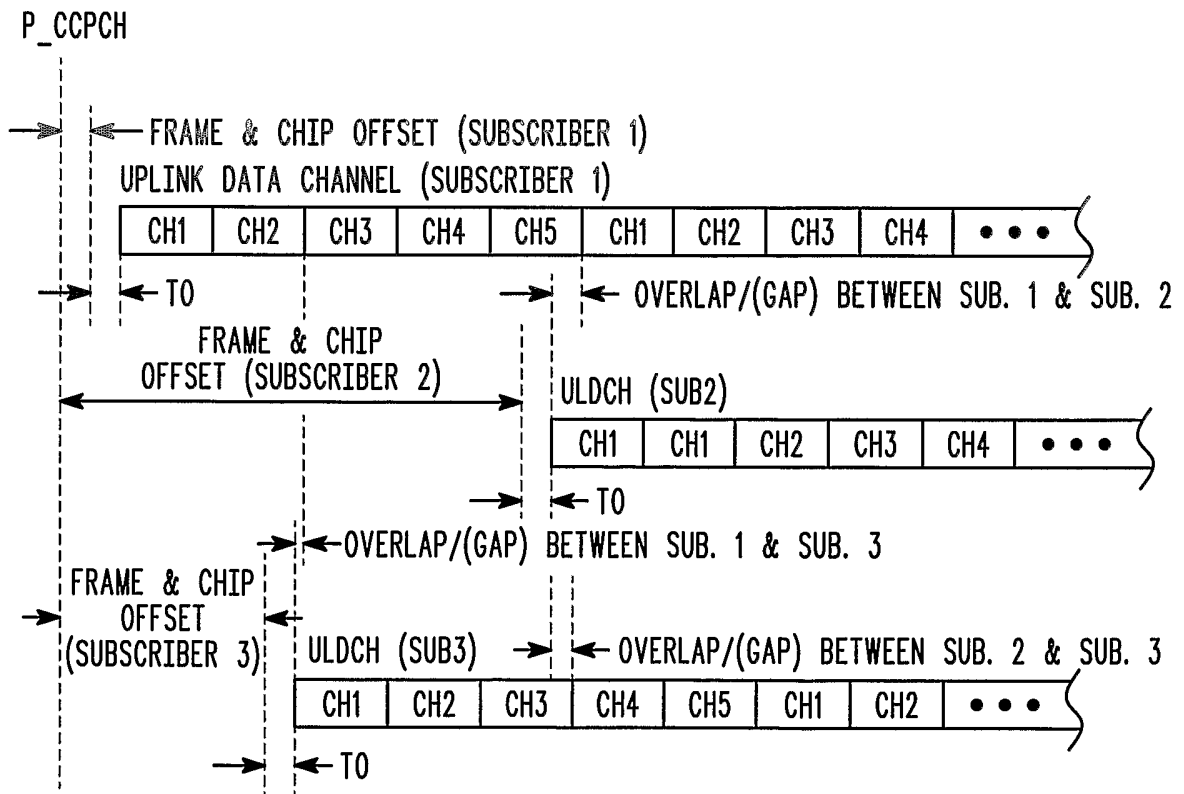
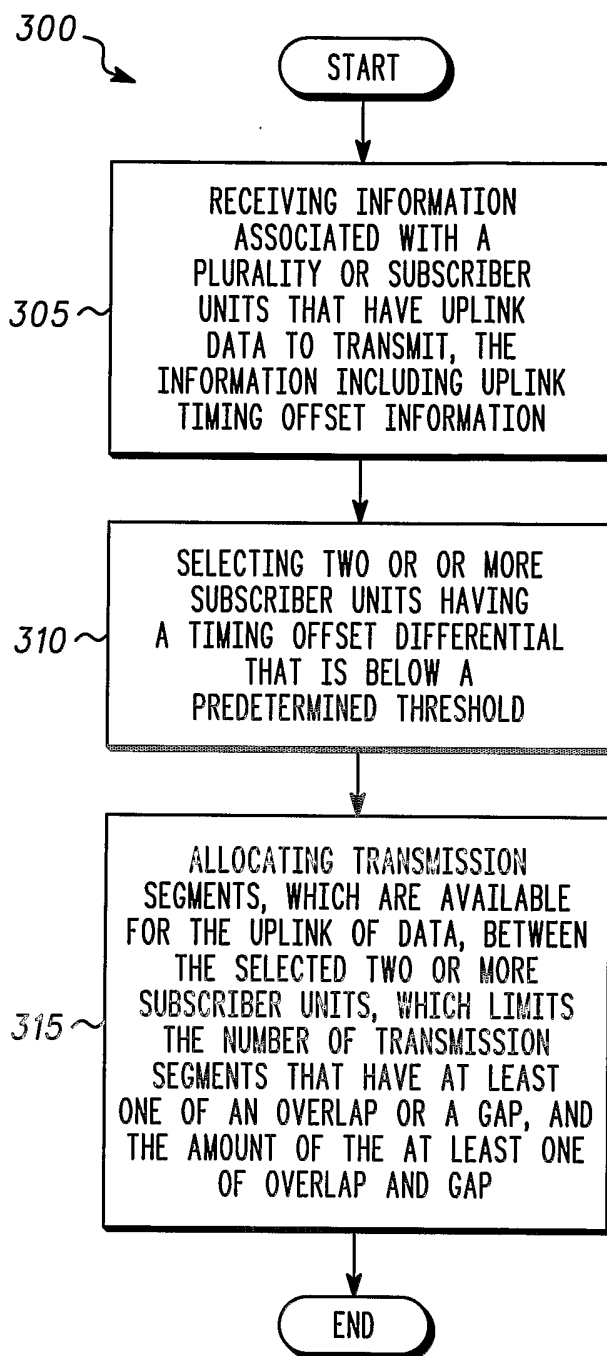

FIG. 6

100

200

4/7

**FIG. 7**

5/7

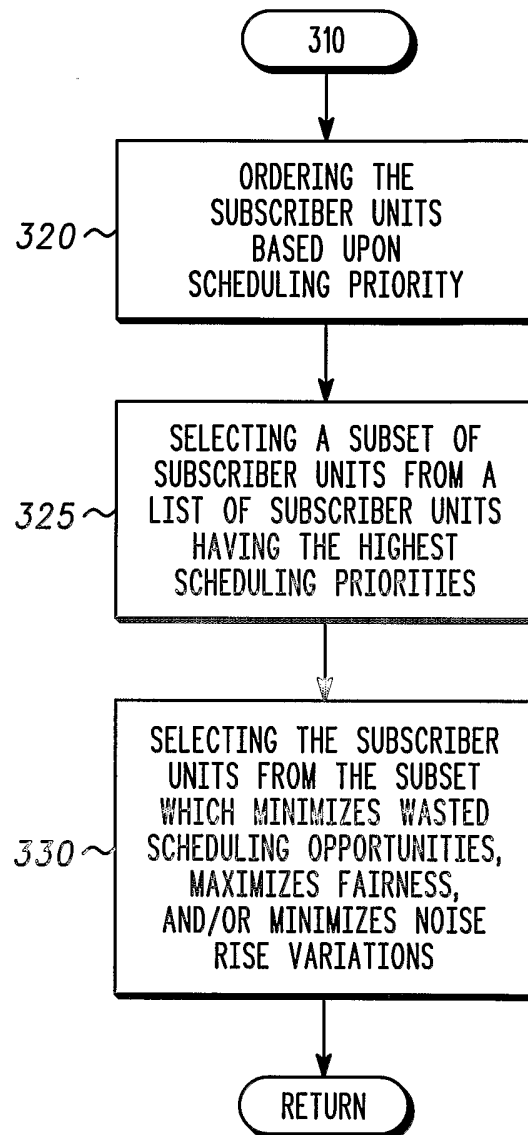
**FIG. 8**

FIG. 9

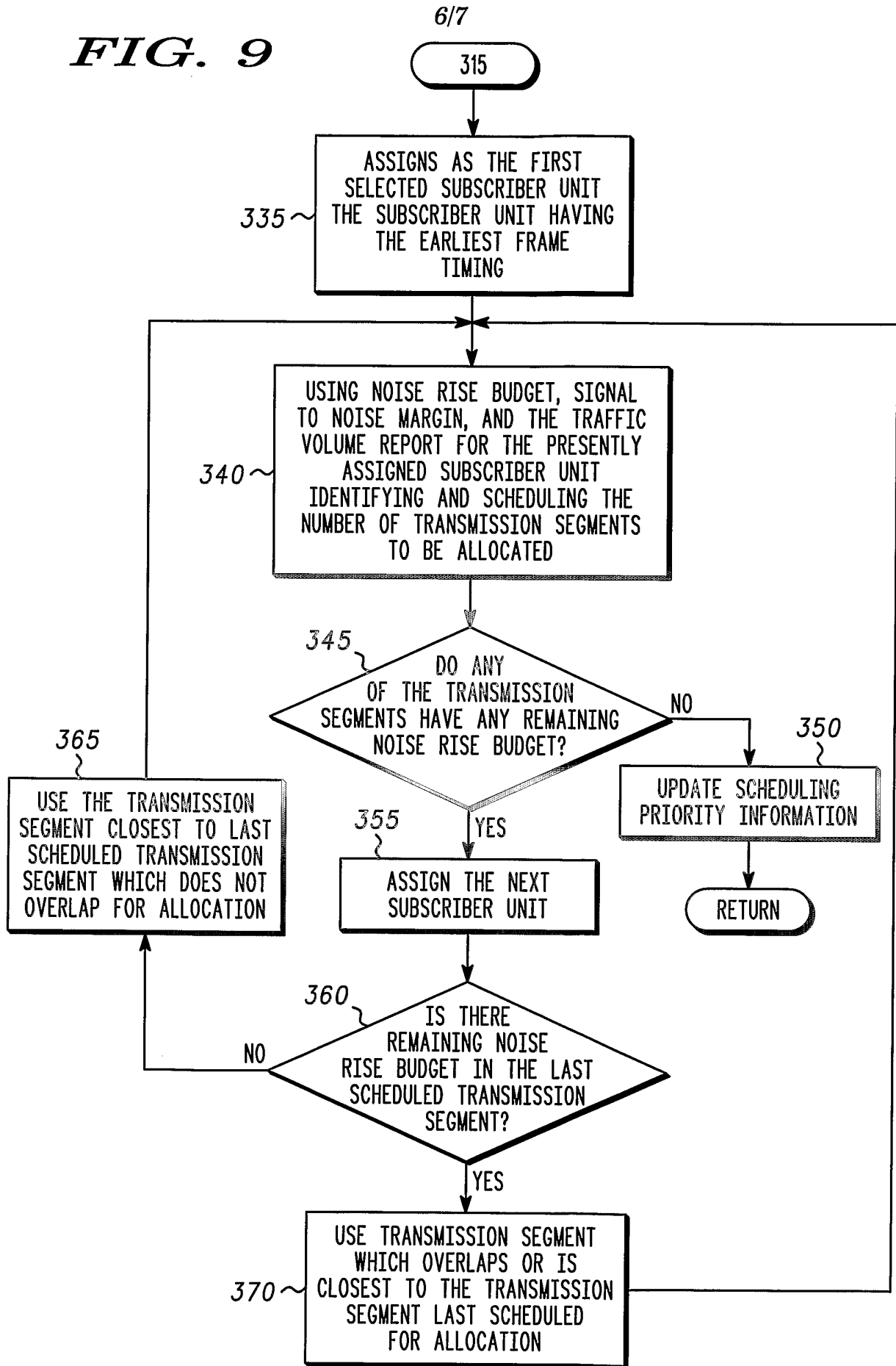
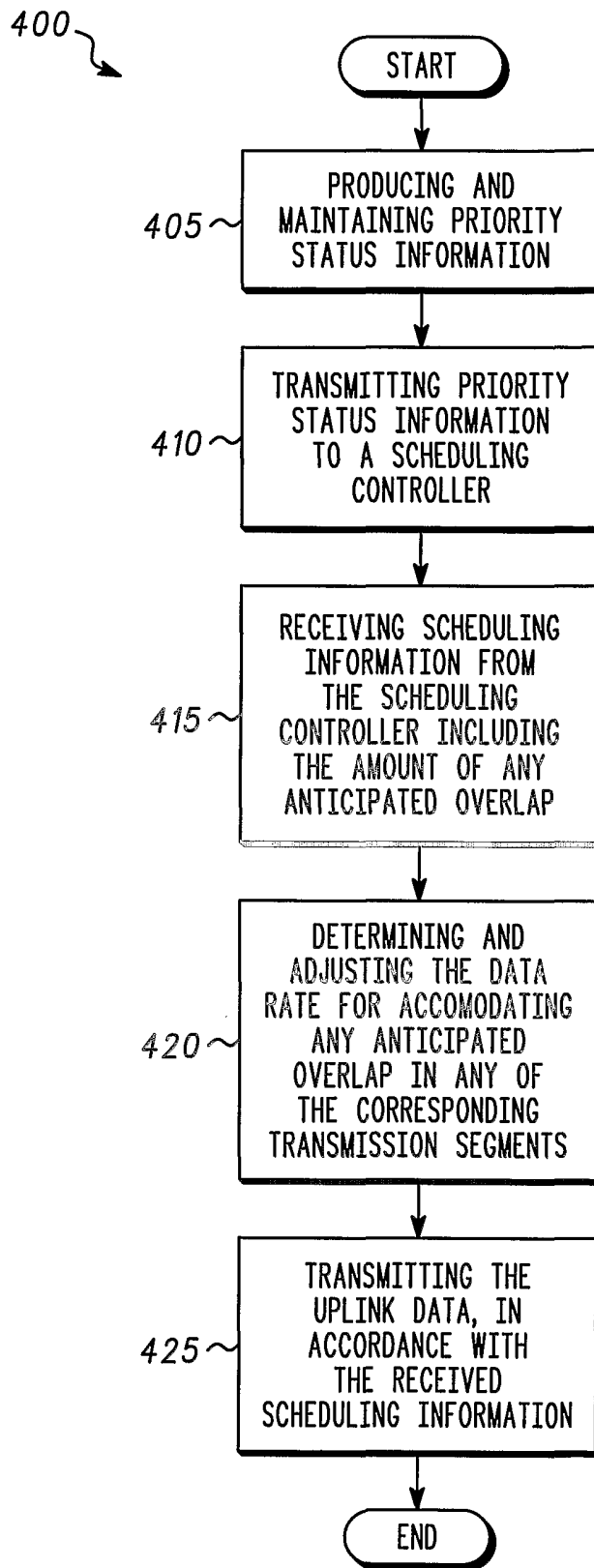

7/7

**FIG. 10**