

*J. Ross.*

*Double-Acting Pump.*

*No. 61,468.*

*Patented Jan. 22, 1867.*

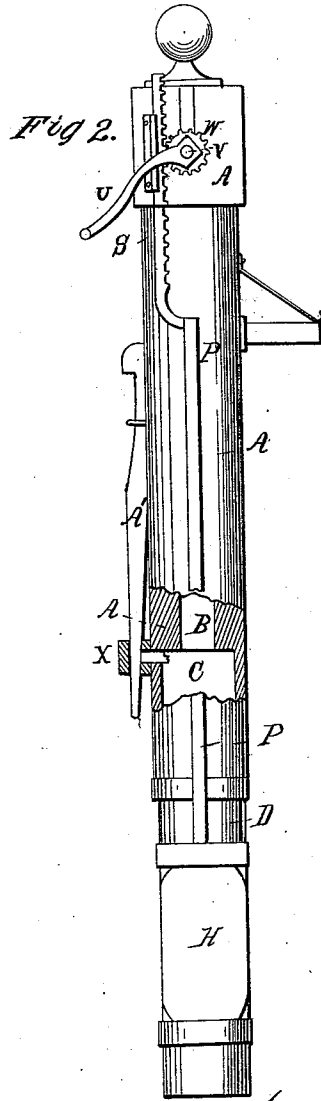
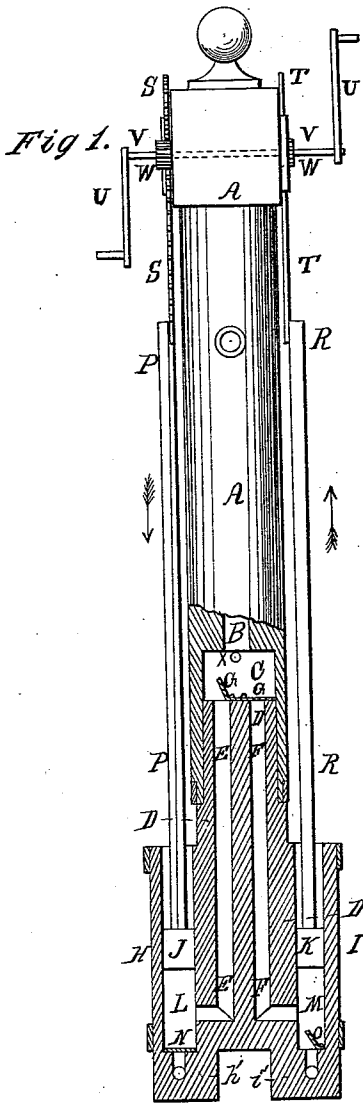

*Witnesses.*

*Geo. A. Sevier*  
*J. W. Huntington*

*Inventor*

*J. Ross*  
*Per Murray*  
*Attorney*

# United States Patent Office.

JOHN ROSS, OF GREENVILLE, MICHIGAN.

Letters Patent No. 61,468, dated January 22, 1867.

## IMPROVEMENT IN PUMPS.

The Schedule referred to in these Letters Patent and making part of the same.

### TO ALL WHOM IT MAY CONCERN:

Be it known that I, JOHN ROSS, of Greenville, in the county of Montcalm, and State of Michigan, have invented a new and useful Improvement in Pumps; and I do hereby declare that the following is a full, clear, and exact description thereof, which will enable others skilled in the art to make and use the same, reference being had to the accompanying drawings, forming a part of this specification, in which—

Figure 1 is a front view of my improved pump, part being broken away to show the construction.

Figure 2 is a side view of the same, part being broken away to show the construction.

Similar letters of reference indicate like parts.

My invention has for its object to furnish an improved pump by means of which water can be raised from deep wells quicker and easier than with the pumps now in use; and it consists, first, in the combination of a crank, pinion-wheel, and rack with each other, with the valve rod, and with the head of the pump stock; second, the combination and arrangement of the centre piece and valve cylinders with each other and with the pump stock; and third, in making the piston rod of such a size as to very nearly balance the weight of the column of water in the pump so that the power required to work a single pump is very little.

A is the pump stock, the bore B of which is made smaller than is usual in other pumps. At the lower end of the pump stock the bore B is enlarged with a chamber, C, into the lower end of which fits the upper end of the centre piece, D. This centre piece D has two bores, E and F, one on each side, as shown in fig. 1, the upper end or mouth of each of which is covered with a valve, G, opening upwards into the chamber C, as shown. Near the bottom of the centre piece D the bores E and F turn at right angles and lead through the sides of the piece D into the valve cylinders H and I. The chambers L and M of these cylinders, in which the pistons J and K work, may be made of sufficient capacity to contain a pailful of water. From the lower parts of these chambers holes or openings lead into the bores E and F of the centre piece D, as above described. In the bottom of the chambers L and M are placed box valves N and O, opening upwards, as shown in fig. 1. From below these valves smaller tubes lead through the lower parts *h'* and *i'* of the cylinders H and I, through which the water enters the cylinders. The lower parts *h'* and *i'* of the cylinders H and I, which project below the lower end of the centre piece D, should be from four to six feet long, so that the piston chambers may, in general, be above the surface of the water. The pistons J and K may be made with a cap at both ends, to be used as forcing or lifting pistons, as may be required. P and R are the piston rods, which pass up outside of the pump stock and terminate in racks S and T. These piston rods should be of such a size as to nearly balance the weight of the column of water within the pump. The racks S and T should be of about the same length as the piston chambers L and M, so that the pump may discharge a pailful of water at each stroke of the piston. U is the crank by which the pump is operated, and which is attached to the end of a shaft, V, revolving in suitable bearings in the head of the pump stock. When the pump is made double, as represented in the drawings, this shaft V may extend through the head of the pump stock and have a crank at each end, as shown. Upon this shaft are placed one or two pinion-wheels, W, according as the pump is made single or double, which mesh into the teeth of the racks S and T and operate the pump. X is a vent tube, which leads into the chamber C of the pump stock, and which is below the freezing point. This vent is closed by the lower end of the rod A', which extends so far up as to be reached and operated from the platform of the pump. By drawing up this rod the vent X is opened and all the water above the freezing point flows from the pump stock.

What I claim as new, and desire to secure by Letters Patent, is—

1. The arrangement of the bore B, bores E F, chamber C, chambers L M, and piston rods P R, secured to racks S T, in combination with the stock A and valve cylinders H I, and operating substantially as described for the purpose specified.

2. In combination therewith the vent tube X of the chamber C, and notched rod A', arranged to operate substantially as and for the purpose specified.

JOHN ROSS.

Witnesses:

CHARLES PARKER,

D. O. BLAKE.