

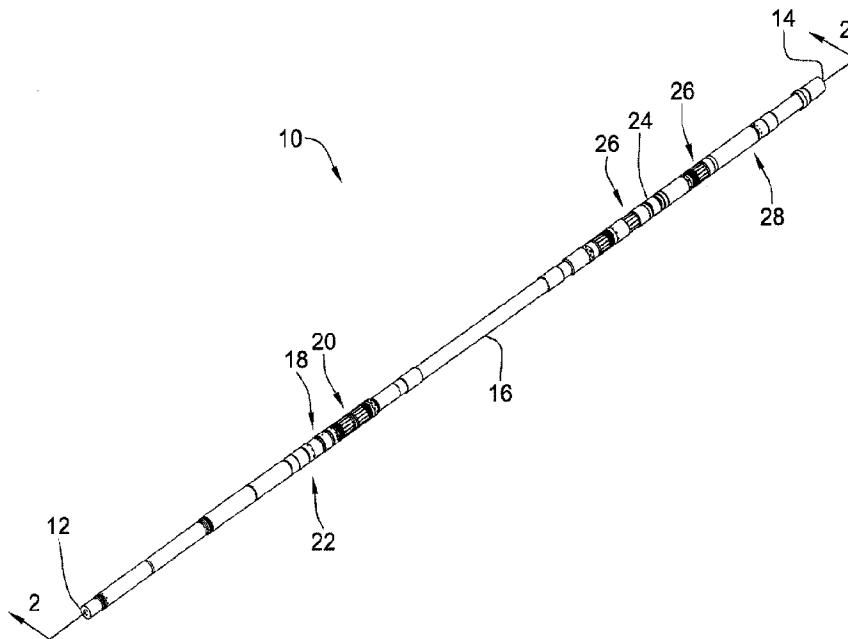

(86) Date de dépôt PCT/PCT Filing Date: 2017/04/10
 (87) Date publication PCT/PCT Publication Date: 2017/10/12
 (45) Date de délivrance/Issue Date: 2023/04/11
 (85) Entrée phase nationale/National Entry: 2018/10/05
 (86) N° demande PCT/PCT Application No.: CA 2017/050440
 (87) N° publication PCT/PCT Publication No.: 2017/173554
 (30) Priorité/Priority: 2016/04/08 (US62/320,209)

(51) Cl.Int./Int.Cl. *E21B 29/10* (2006.01),
F16L 55/165 (2006.01)
 (72) Inventeurs/Inventors:
GEORGE, GRANT, CA;
MCCARTHY, MATTHEW, CA
 (73) Propriétaire/Owner:
TORSCH INC., CA
 (74) Agent: OKIMAW, RICHARD D.

(54) Titre : **PIECE DE TUBAGE DE FOND DE TROU**
 (54) Title: **DOWNHOLE CASING PATCH**



(57) **Abrégé/Abstract:**

An apparatus for bridging a section of ruptured casing within an oil well comprising a length of bridging pipe extending between first and second ends sized to be located within the casing so as to span the section of ruptured casing, a first seal located around the bridging pipe proximate to the first end thereof, a second seal located around the bridging pipe proximate to the second end thereof, an installation assembly extending through the bridging pipe operably engaged with the first and second ends of the bridging pipe, wherein the installation assembly is operable to extend each of the first and second seals into engagement with the oil well and wherein the installation assembly is further operable to selectably disengage from the bridging pipe.

-33-

ABSTRACT

An apparatus for bridging a section of ruptured casing within an oil well comprising a length of bridging pipe extending between first and second ends sized to be located within the casing so as to span the section of ruptured casing, a first seal located around the bridging pipe proximate to the first end thereof, a second seal located around the bridging pipe proximate to the second end thereof, an installation assembly extending through the bridging pipe operably engaged with the first and second ends of the bridging pipe, wherein the installation assembly is operable to extend each of the first and second seals into engagement with the oil well and wherein the installation assembly is further operable to selectably disengage from the bridging pipe.

DOWNHOLE CASING PATCH**BACKGROUND OF THE INVENTION****1. Field of Invention**

5 The present invention relates generally to a method and apparatus for bridging and sealing a compromised downhole casing.

2. Description of Related Art

10 In hydrocarbon production, many casings or production tubes may be prone to fatigue and/or wear. These stresses on the casing may cause such casing to crack or rupture leading to loss of integrity of the well bore. Such operations may occur in the case of steam assisted gravity drainage or SAGD operations or primary operations.

15 One method of repairing such a rupture is to provide a bridging pipe or liner inside of the ruptured casing with seals on each end. However present methods of installing and activating such bridges are time consuming and difficult to install. Such conventional bridging pipes have also suffered from short service lives and have been unable to be retrieved from the well.

20

SUMMARY OF THE INVENTION

According to a first embodiment of the present invention, there is disclosed an apparatus for bridging a section of ruptured casing within an oil well comprising a length of bridging pipe extending between first and second ends sized to be
25 located within the casing so as to span the section of ruptured casing, a first seal located around the bridging pipe proximate to the first end thereof, a second seal located around the bridging pipe proximate to the second end thereof, an installation assembly extending through the bridging pipe operably engaged with the first and second ends of the bridging pipe, wherein the installation assembly
30 is operable to extend each of the first and second seals into engagement with the oil well and wherein the installation assembly is further operable to selectably disengage from the bridging pipe.

-2-

5 The first seal may comprise top and bottom first seal collet arms extending away from a first seal retaining ring disposed around the bridging pipe, each of the top and bottom first seal collet arms extending to distal ends having outwardly oriented pipe engagement surfaces, top and bottom first seal cones positioned adjacent to the distal ends of the top and bottom first seal collet arms around the bridging pipe, first seal engagement sleeve surrounding the bridging pipe proximate to the first end thereof and a first seal element extending around the bridging pipe between the top first seal cone and the first seal engagement sleeve

10

The first seal retaining ring, the top first seal cones and the first seal engagement sleeve may be temporarily secured to the bridging pipe with shear pins. The shear pins securing the first seal retaining ring, the top first seal cones and the first seal engagement sleeve may be sheared in order from top to bottom as the bridging pipe moves therethrough. The first seal retaining ring, the top first seal cones and the first seal engagement sleeve may be removed from engagement with the oil well by retrieval rings adapted to engage thereupon. The first seal retaining ring, the top first seal cones and the first seal engagement sleeve may be engaged upon in order from top to bottom by the retrieval rings.

20

25 The second seal may comprise top second seal collet arms extending downwardly from a top collet retaining ring disposed around the bridging pipe, the top second seal collet arms extending to distal ends having outwardly oriented pipe engagement surfaces, top and bottom second seal cones positioned below the top second seal collet arms around the bridging pipe, a second seal element extending around the bridging pipe between the top and bottom second seal cones, bottom second seal collet arms extending upwardly from a bottom collet retaining ring disposed around the bridging pipe, the bottom second seal collet arms extending to distal ends having outwardly oriented pipe engagement surfaces, second seal engagement sleeve surrounding the bridging pipe proximate to the second end thereof and The top collet retaining ring, the top and bottom second seal cones, the bottom retaining ring and the

30

-3-

second seal engagement sleeve are temporarily secured to the bridging pipe with shear pins.

5 The shear pins securing the top collet retaining ring, the top and bottom second seal cones, the bottom retaining ring and the second seal engagement sleeve may be sheared in order from bottom to top as the bridging pipe moves therethrough. The top collet retaining ring, the top and bottom second seal cones, the bottom retaining ring and the second seal engagement sleeve may be removed from engagement with the oil well by retrieval rings adapted to
10 engage thereupon. The top collet retaining ring, the top and bottom second seal cones, the bottom retaining ring and the second seal engagement sleeve may be engaged upon in order from top to bottom by the retrieval rings. The shear pin securing the top collet retaining ring is sized larger than the shear pins securing the top and bottom second seal cones, the bottom retaining ring and
15 the second seal engagement sleeve may be temporarily secured to the bridging pipe with shear pins. The apparatus may further comprise a selectably compressible sleeve between the top second seal cone and the second seal element.

20 The selectably compressible sleeve may comprises a plurality of release arms extending from a sleeve adjacent to the second seal element, the plurality of release arms having end surfaces selectably engageable with a corresponding receptacle sleeve extending from the top second seal cone, wherein the end surfaces of the release arms are maintained in engagement with the receptacle
25 sleeve by the bridging pipe, wherein the recess is located at a position along the bridging pipe corresponding to a position at which the release arms are desired to be released from engagement with the receptacle sleeve.

30 The bridging pipe may include a plurality of longitudinal slots extending therealong and further including a carriage within each slot in engagement with the second seal engagement sleeve so as to transmit longitudinal movement of a tool inside the bridging pipe to the second seal engagement sleeve.

-4-

5 According to a further embodiment of the present invention, there is disclosed a method for bridging a section of pipe having a compromised section comprising providing a length of bridging pipe extending between first and second ends located within the casing so as to span the section of ruptured casing, locating
10 an installation assembly within the bridging pipe, positioning the bridging pipe within the pipe so as to span the section of ruptured casing, with the installation assembly, longitudinally compressing the first end of the bridging pipe so as to extend a first seal therearound located proximate to the first end of the bridging pipe, releasing the installation assembly from the first end of the bridging pipe,
15 with the installation assembly, longitudinally compressing the second end of the bridging pipe so as to extend a second seal therearound located proximate to the second end of the bridging pipe, releasing the installation assembly from the second end of the bridging pipe, removing the installation assembly from the bridging pipe.

20 According to a further embodiment of the present invention, there is disclosed an apparatus for selectively decoupling a setting tool from a pipe comprising an inner tubular body locatable within the pipe, an outer tubular body located annularly between the pipe and the inner tubular body, a plurality of collet arms
25 extending from the outer tubular body, the plurality of collet arms having an exterior gripping surface engagable upon the pipe and a catch extending between the inner tubular body and the outer tubular body so as to selectably lock the inner and outer tubular bodies together.

30 The catch may comprise at least one radially movable pin extending between aid inner and outer tubular bodies wherein the at least one pin engages the inner and outer tubular body at a first radially extended position and disengages from the outer tubular body at a second radially compressed position. The apparatus may further comprise a sleeve longitudinally displaceable within a
central bore of the inner tubular body so as to retain the at least one pin at the first position. The sleeve is longitudinally displaceable to permit the at least one pin to move to the second position.

-5-

The inner tubular body includes a cone at a position to bias the plurality of collet arms into engagement with the pipe at an initial position.

5 According to a further embodiment of the present invention, there is disclosed a method for selectively decoupling a setting tool from a pipe comprising locating an inner tubular body within the pipe, locating an outer tubular body annularly between the pipe and the inner tubular body, biasing a plurality of collet arms extending from the outer tubular body into engagement with the pipe and selectably longitudinally retaining inner and outer tubular bodies relative to each other with a catch extending between the inner tubular body and the outer tubular body so as to selectably.

10

According to a further embodiment of the present invention, there is disclosed an apparatus for selectively retaining and releasing a dropped ball within a down hole tool comprising a body locatable within the down hole tool having a central passage therethrough, the central passage having an enlarged cavity section, a slidably tubular member having a central passage therethrough located within the cavity section, a plurality of collet arms longitudinally extending upwardly from the tubular member, each collet arm extending to a free distal end wherein the free distal arms define a ball seat and a retaining ring positioned to surround the free distal ends of the collet arms so as to retain the free distal ends at a radially compressed configuration, wherein the slidably tubular member is slidable between a first position wherein the retaining ring compresses the free distal ends of the plurality of collet arms and second position wherein the collet arms are disengaged from the retaining ring so as to be permitted to radially expand.

15

20

25

The apparatus may further comprise at least one shear pin adapted to selectably retain the slidable tubular member at the first position.

30

According to a further embodiment of the present invention, there is disclosed a method for selectively retaining and releasing a dropped ball within a down hole tool comprising providing a body within the down hole tool having a central

-6-

5 passage therethrough, the central passage having an enlarged cavity section, locating a slidably tubular member having a central passage therethrough within the cavity section, providing a plurality of collet arms longitudinally extending upwardly from the tubular member, each collet arm extending to a free distal end wherein the free distal arms define a ball seat and locating a retaining ring around the free distal ends of the collet arms to as to retain the free distal ends at a radially compressed configuration, slidably displacing the tubular member from a first position wherein the retaining ring compresses the free distal ends of the plurality of collet arms and second position wherein the collet arms are disengaged from the retaining ring so as to be permitted to radially expand thereby permitting the ball to pass therethrough.

15 According to a further embodiment of the present invention, there is disclosed a packer setting tool comprising an inner cylinder having an inner passage extending therethrough, the inner cylinder being securable to an inner housing of the packer, an outer cylinder annularly surrounding the inner cylinder, the outer cylinder being slidably relative to the inner cylinder and having a diameter selected to longitudinally engage an outer longitudinally movable sleeve of the packer, at least one annular piston located within an annular cavity between the inner and outer cylinders, the at least one annular piston connected to the outer cylinder, at least one port extending between the inner passage and the annular cavity so as to transmit a pressure within the inner passage to the annular cavity thereby displacing the at least one annular piston and the outer cylinder in a direction towards the packer so as to bear thereupon.

25 According to a further embodiment of the present invention, there is disclosed a method for setting a packer comprising securing an inner cylinder having an inner passage extending therethrough, the inner cylinder being to an inner housing of the packer, slidably locating an outer cylinder annularly around the inner cylinder, the outer cylinder having a diameter selected to longitudinally engage an outer longitudinally movable sleeve of the packer, transmitting a pressureized fluid within the inner passage through the inner cylinder to an annular cavity between the inner and outer cylinders thereby displacing at least

30

one annular piston located within the annular cavity, wherein the at least one annular piston are connected to the outer cylinder thereby displacing the at least one annular piston and the outer cylinder in a direction towards the packer so as to bear thereupon.

5

According to a further embodiment of the present invention, there is disclosed an apparatus for coupling a top down hole assembly to a bottom down hole assembly for removal from a well bore comprising a first pipe extending longitudinally upward from the bottom down hole assembly, a second pipe extending longitudinally downwards from the top down hole assembly sized to be received within the first pipe, an end assembly on a distal end of the first pipe assembly and a tag ring located within the first pipe coupled to the end assembly, the tag ring sized to longitudinally abut the second pipe to as to prevent the second pipe from passing therethrough.

10

15

The second pipe may includes a stinger tube extending from a bottom end thereof sized to pass through the tag ring. The tag ring may be releasably secured to the end assembly by at least one radial pin extending from the tag ring engagable within a j-shaped slot within the end assembly. The tag ring and a distal end of the second pipe may include castellations adapted to engage upon each other permitting the second pipe to rotate the tag ring out of engagement with the end assembly. The second pie may include a plurality of angularly oriented rings therearound wherein the end assembly includes a corresponding angularly oriented ring so as to permit the second pipe to be passed therethrough in a direction towards the bottom down hole assembly and prevent movement of the second pipe away from the bottom down hole assembly.

20

25

30

According to a further embodiment of the present invention, there is disclosed a method for coupling a top down hole assembly to a bottom down hole assembly for removal from a well bore comprising providing a first pipe extending longitudinally upward from the bottom down hole assembly, providing an end assembly on a distal end of the first pipe assembly and slidably inserting a

-8-

second pipe extending longitudinally downwards from the top down hole assembly within the first pipe, abutting a distal end of the second pipe against a tag ring located within the first pipe coupled to the end assembly and rotating the second pipe relative to the first pipe so as to engage castellations on each of the distal end of the second pipe and the tag ring and disengage at least one pin from the tag ring from j-shaped slots in the end assembly.

Other aspects and features of the present invention will become apparent to those ordinarily skilled in the art upon review of the following description of specific embodiments of the invention in conjunction with the accompanying figures.

BRIEF DESCRIPTION OF THE DRAWINGS

In drawings which illustrate embodiments of the invention wherein similar characters of reference denote corresponding parts in each view,

- Figure 1 is a perspective view of a casing patch assembly according to a first embodiment of the present invention.
- Figure 2 is a cross sectional view of the casing patch assembly of Figure 1 as taken along the line 2-2.
- Figure 3 is a detailed cross sectional view of the setting tool for use in the casing patch assembly of Figure 1.
- Figure 4 is a detailed cross sectional view of the top seal and running tool for use in the casing patch assembly of Figure 1 at a first or run in position.
- Figure 5 is a detailed cross sectional view of a middle portion and a portion of the bottom seal of the casing patch assembly of Figure 1 at a first or run in position.
- Figure 6 is a detailed cross sectional view of a portion of the bottom seal and release tool for use in the casing patch assembly of Figure 1 at a first or run in position.
- Figure 7 is an illustration of an assembly for patching a casing according to a further embodiment at a first or run in position.

- Figure 8 is an illustration of the assembly of Figure 7 at a second or setting position.
- Figure 9 is an illustration of the assembly of Figure 7 at a third or released position.
- 5 Figure 10 is detailed cross sectional view of the setting tool for use in the casing patch assembly of Figure 1 at a second or extended position.
- Figure 11 is a detailed cross sectional view of the running tool for use in the casing patch assembly of Figure 1 at a first or run in position.
- 10 Figure 12 is detailed cross sectional view of the running tool for use in the casing patch assembly of Figure 1 at a second position with a ball engaged upon the ball seat.
- Figure 13 is detailed cross sectional view of the running tool for use in the casing patch assembly of Figure 1 at a third or release position shifted down to expand the collet arms and release the ball.
- 15 Figure 14 is detailed cross sectional view of the collet arms of the running tool for use in the casing patch assembly of Figure 1 at the third or release position.
- Figure 15 is a detailed cross sectional view of the top seal for use in the casing patch assembly of Figure 1 at a first or run in position.
- 20 Figure 16 is a detailed cross sectional view of the top seal for use in the casing patch assembly of Figure 1 at a second or expanded position.
- Figure 17 is a detailed cross sectional view of the release tool for use in the casing patch assembly of Figure 1 according to a further embodiment of the present invention at a first or run in position.
- 25 Figure 18 is a detailed cross sectional view of the release tool of Figure 17 with the shifting release sleeve removed for clarity at the first position.
- 30 Figure 19 is a detailed cross sectional view of the release tool of Figure 17 with the shifting release sleeve removed for clarity at a second or activated position.

-10-

- Figure **20** is a detailed cross sectional view of the second seal for use in the casing patch assembly of Figure **1** at a second or extended position.
- 5 Figure **21** is detailed side view of the ball seat body showing the passages for passing the shear release pins.
- Figure **22** is detailed cross sectional view of the upper collet sleeve for use in the casing patch assembly of Figure **1**.
- Figure **23** is side view of a first assembly for use in forming the casing patch assembly of Figure **1**.
- 10 Figure **24** is side view of a second assembly for use in forming the casing patch assembly of Figure **1**.
- Figure **25** is detailed cross sectional view of an end assembly for coupling the first assembly of Figure **23** to the second assembly of Figure **24** with the connection pipe approaching the end assembly.
- 15 Figure **26** is detailed cross sectional view of the end assembly of Figure **25** with the connection pipe engaged in the tag ring and removed from the end assembly.
- Figure **27** is detailed cross sectional view of the release collet arms of the running tool.
- 20

DETAILED DESCRIPTION

Referring to Figure **1**, an assembly for bridging a compromised section of a down-well casing according to a first embodiment of the invention is shown generally at **10**. The assembly **10** extends between first and second ends, **12** and **14**, respectively and includes a central bridging pipe **16** adapted to be located within the compromised section of casing and sealed therein as will be more fully described below. The bridging pipe **16** of the apparatus **10** includes a first seal **18** and first pair of gripping collet arms **20** located proximate to a first end **22** thereof and a second seal **24** and a second pair of gripping collet arms **26** located proximate to a second end **28** thereof. In operation, the first and second collet arms and seals are extended into engagement with the casing after the bridging pipe portion is located in the

25

30

-11-

desired location so as to seal the compromised portion of the pipe and repair any perforations or ruptures therein.

5 Turning now to Figures 2 through 20, a cross sectional view of the assembly of Figure 1 is shown. The assembly includes a bridging pipe 16 having an inner pipe assembly 80 extending through in interior thereof. As illustrated in greater detail in Figure 3, the assembly includes a setting tool 40 at the first end thereof. The setting tool 40 includes the first end 12 of the assembly which may include an internal threading for connection to a tool string as is commonly known. The setting tool is adapted to utilize pressure within the tool string or the annulus between the tool string and the casing to extend the seals into engagement with the casing.

15 As shown in Figures 3 and 10, the setting tool 40 comprises an outer tubular portion 42 and an inner tubular portion 44 forming an annular chamber 46 therebetween. The annular chamber 46 is sealed at the leading edge by an end body 48 of the setting tool and includes an annular piston 50 therein. The annular piston 50 is operably connected to the outer tubular portion 42 and slidably sealed to the inner tubular portion 44. A passage 52 extends between the interior of the inner tubular portion 44 and a boundary between the annular piston 50 and the end body 48 so as to convey pressure within the interior of the tool string therebetween. In operation when a user desires to extend the seals, an increasing pressure is applied to the interior of the tool string so as to pressurize the location between the annular piston 50 and the end body 48 so as to move the annular piston 50 and thereby the outer tubular portion 42 in a direction towards the second end 14 of the assembly. Details of the extension of such seals will be provided further below. As illustrated in Figure 3, the setting tool 40 may include a second set of pistons generally indicated at 53 secured to each of the inner tubular portion 44 and outer tubular portion 42 so as to increase the force which the setting tool may apply. As illustrated in figure 3, the setting tool includes a transfer sleeve 43 sized to correspond to the matching first end sleeve 17 of the bridging pipe 16.

-12-

Turning now to Figure 4 and 11, a detailed view of an auto tripping ball seat 60 for forming the desired pressure within the setting tool 40 is illustrated. The auto tripping ball seat 60 is secured to the inner tubular portion 44 of the setting tool so as to be run into and retrieved from the well as a single component. In particular, the auto tripping ball seat 60 may comprise an upper slidable tubular member 62 located within a ball seat body 64. The upper slidable tubular member 62 includes a plurality of collet arms 66 at a leading edge thereof forming a ball seat 67 at a leading edge of the slidable tubular member 62. The upper slidable tubular member 62 is sealably secured within a cavity 68 in the ball seat body 64 by set screws or the like and the collet arms 66 are adapted to be retained in the reduced orientation as shown to retain a dropped ball by engagement upon the cavity 68 as illustrated in Figure 12. The cavity 68 includes an expanded portion 70 downstream of the initial position of the collet arms 66 such that at a sufficiently high enough pressure, the set screws 69 will be broken and the upper slidable tubular member 62 is permitted to shift in a direction towards the second end 14 of the assembly thereby also permitting the collet arms to expand and release the ball to pass therethrough as illustrated in Figure 13. The upper slidable tubular member 62 also includes an annular recess 72 in an exterior thereof wherein the ball seat body 64 include a plurality of keys 74 extending therethrough into engagement with an upper collet sleeve 73 inside the first end sleeve 17 and engages upon the first end 22 of the bridging pipe 16. As the upper slidable tubular member 62 shifts toward the second end 14 of the assembly 10, the keys 74 are permitted to retract into the annular recess 72 and out of engagement with the upper collet sleeve 73 thereby decoupling the ball seat body from the upper collet sleeve 73 and bridging pipe 16. As a safety precaution if sufficient pressure does not shift the ball seat downwardly, the setting tool may be rotated to shear release pins 200 thereby releasing collet arms 120. As illustrated in Figures 21 and 22, the shear release pins 200 pass through bores 202 in the ball seat body 64 and bores 204 in the upper collet sleeve 73. The shear release pins 200 prevent rotation between the ball seat body 64 and the upper collet sleeve 73 thereby

-13-

retaining the keys **74** within notches **206** in the upper collet sleeve **73**. Upon shearing of the shear release pins **200**, the keys **74** may be rotated into enlarged portions **208** in the bore of the upper collet sleeve **73** thereby permitting longitudinal movement therebetween. As illustrated in Figure **27**,
5 the release collet arms **120** may have a dovetailed profile received within corresponding dovetail slots on the cone so as to retract the release collet arms **120** as the cone is moved down hole.

As illustrated in Figures **4** and **5**, the assembly includes an inner pipe
10 assembly **80** extending between the ball seat body **64** and the release apparatus **90** as will be more fully described below. The inner pipe assembly **80** ensures that the entire contents of the interior of the bridging pipe **16** may be removed after setting the bridging pipe. With reference to Figure **6**, the release apparatus **90** is illustrated which includes the second end **14** of the
15 assembly. The release apparatus **90** includes a release body **92** extending from and connected to the inner pipe assembly **80**. The release body forms an inner passage having a bottom cavity **94** adapted to sealably receive a lower tubular sliding member **96** therein. The lower tubular sliding member **96**
20 includes a ball catch surface **97** at a leading edge thereof adapted to receive and retain a dropped ball thereon. The lower tubular sliding member **96** is secured to the release body **92** through the use of shear pins **99**.

As illustrated in Figure **6** the release apparatus **90** further includes a plurality
25 of retaining arms **98** extending from the release body **92** into engagement with the interior of the bridging pipe **16** which are retained in engagement therewith by a backing body **100**. The backing body **100** is slidably located around the release body **92** and secured thereto with a plurality of lower keys **102** or the like. The lower keys **102** are retained in such engagement by the lower tubular sliding member. As illustrated in Figure **6**, the lower tubular sliding
30 member **96** includes an annular recess **104** therein adapted to release the lower keys **102** from engagement with the backing body **100**. In operation, a sufficiently high enough pressure applied to a ball on the lower tubular sliding member **96** will rupture or shear the shear pins **99** thereby allowing the lower

-14-

tubular sliding member **96** to shift towards the second end **14** of the assembly. If the ball cannot seat on the bottom seat due to damage from the first seat or any other reason, then a second larger ball can be dropped to land in ball catch surface **97**. At such position, the lower keys **102** will be permitted to retract into the annular recess **104** thereby disengaging the release body **92** from the backing body **100** and thereby permitting any movement of the inner pipe assembly **80** and therefore the release body **92** in a direction towards the first end **12** of the assembly to disengage the retaining arms **98** from the bridging pipe **16**. After such disengagement, the release apparatus **90** may be removed from the interior of the bridging pipe **16** along with the inner pipe assembly **80**. If pressure cannot shear pins **99** and the release apparatus **90** then an over pull condition may be applied to shear a weakened location on the collet arms **98** that will allow the inner pipe assembly **80** and release apparatus **90** to be pulled out of the hole.

Turning now to Figures **7** through **9**, a sequence of operation for utilizing the assembly is illustrated. In operation, the assembly **10** may be located within a ruptured casing with the first and second seals **18** and **24** to either side thereof. To extend the seals, a ball may be dropped down the tool string to engage upon the ball seat **67** on the first slidable tubular member **62**. Applying pressure to the tool string will urge the annular piston **50** and the end body **48** apart until the transfer sleeve **43** engages the bridging pipe **16**. As the inner pipe assembly **80** and thereby the release apparatus are connected to the second end **28** of the bridging pipe **16**, such engagement and further movement will urge the top edge of the bridging pipe **16** in a direction towards the second end **14** of the assembly and extend the first seal **18** and gripping collet arms **20**.

After the first seal **18** has been set, further increasing the pressure within the tool string will thereafter shear the set screws between the first slidable tubular member **62** and the ball seat body **64** thereby permitting the first slidable tubular member to shift as set out above which will release the ball to pass therethrough to the lower tubular sliding tubular member **96**.

-15-

Furthermore, a downward force upon the setting tool **40** towards the second end **14** of the apparatus will further cause the collets arms **120** to retract from engagement with the bridging pipe **16**.

5 As illustrated in Figure **17**, a bottom seal activation assembly **400** may include a release mechanism in an alternative embodiment to the release mechanism **90** shown in Figure **6**. The bottom seal activation assembly **400** may include a further auto tripping ball seat **60** as set out above for providing a second
10 extending force to the setting tool. It will be appreciated that the second auto tripping ball seat **60** may be located at any location within the assembly so as to provide a pressure increase thereto. Additionally, it will be appreciated that at such time, the retrieval collet arms **120** will have been disengaged from the bridging pipe **16** so as to permit inner pipe assembly **80** to move relative to the bridging pipe **16**. Accordingly pressuring the annular chamber **46** will pull
15 upward on the inner pipe assembly **80** relative to the bridging pipe **16** which is secured at the first seal **18** to the well bore.

As illustrated in Figure **18**, the bottom seal activation assembly **400** is included proximate to the second end **14** of the bridging pipe **16**. The bottom
20 seal activation assembly **400** includes a plurality of carriages **402** located within slots **404** through a bottom pipe extension **19**, extending from the second end **28** of the bridging pipe **16**. The inner pipe assembly **80** includes a plurality of pulling arms **406** extending therefrom which are spaced annularly around the inner pipe assembly **80** with splines **408** therebetween. The
25 pulling arms **406** are secured to a pulling sleeve **410** with shear pins **412**. As the inner pipe assembly **80** pulls upwardly in a direction generally indicated at **420**, the pulling arms **406** pull upwardly on the pulling sleeve **410** to engage upon the carriages **402** which are then moved through the slots **404** to extend the second seal **24** and second pair of gripping collet arms **26** as set out
30 below.

Thereafter further increasing the pressure through the tool string will again urge the annular piston **50** (as shown in Figures **3** and **10**) and the end body

-16-

5 **48** apart so as to pull upward on the inner tubular portion **44** against the first pair of collet arms **20**. Such movement of the inner tubular portion **44** will act through the inner pipe assembly **80** so as to pull upward on the second end **28** of the bridging pipe **16**. Such upward movement of the second end **28** of the bridging pipe **16** will compress the bridging pipe **16** so as to extend the second seal **24** and second pair of gripping collet arms **26** into engagement with the casing. At such time a test pressure may be applied to the annulus between the tool string and the casing to test the integrity of the seals. As illustrated in figure **17**, the bottom portion of the assembly may include inner packer cups **450** and outer packer cups **542** adapted to seal the annulus of the well bore to the assembly **10** as well as seal the bridging pipe **16** to the inner pipe assembly **80** thereby permitting such pressure test.

15 After the seals have been verified, the pressure within the annulus may be reduced and the pressure within the tool string again increased to shear the shear pins of the lower tubular sliding member **96**. After such shear pins have been sheared, the release apparatus and therefore the inner pipe and setting tool may be removed from the bridging pipe.

20 In operation, the first and second pairs of gripping collet arms **20** and **26** are extended by cones **25** which are urged under the ends of the pairs of gripping collet arms **20** and **26**. Each of the cones, and collet arms are initially secured to the bridging pipe by set screws which are sheared as the bridging pipe is compressed by the setting tool. The first end of the bridging pipe **16** is indexed to the first pair of gripping collet arms **20** by a ratchet **30** therebetween to permit movement therebetween caused by the shifting tool, but not thereafter whereas the bottom most cone is secured to the bridging pipe **16** by a larger set screw **34** selected to remain in place after setting of the collet arms. Furthermore, the second pair of gripping collet arms **26** are retained in position by a larger set screw **32** as illustrated in Figure **5** which will maintain the second pair of gripping collet arms **26** at a position along the bridging pipe **16** until a sufficiently large enough thermal expansion force is applied to the bridging pipe whereafter they will be sheared permitting the

-17-

second pair of gripping collet arms **26** and second seal to float along the bridging pipe so as to permit thermal expansion of the bridging pipe **16**.

5 After being set in place the setting tool **40** and release apparatus **90** can be removed from the bridging pipe **16** to permit operation of the well again as set out above. When the bridging pipe **16** is desired to be removed, the setting tool including the auto tripping ball seat **60** can again be run into the well bore to engage and release the collet arms. The setting tool **40** includes a downwardly oriented a retrieval ring **125** at a position adapted to engage upon
10 retrieval grips **127** on the release collet arms **120** as illustrated in Figures **11** and **14**. After the top seal has been set, upward motion of the inner pipe assembly **80** as set out above will pull the release collet arms **120** out of the bridging pipe as well wherein the retrieveal ring **125** prevents the release collet arms **120** from moving relative to the cone **122** so as to prevent them
15 from re-engaging upon the bridging pipe **16**.

After being located within the bridging pipe **16**, a ball may again be dropped to be located on the ball seat **67** so as to cause the inner tubular portion **44** to be moved upward relative to the outer tubular portion **42** as set out above. In
20 order to remove the bridging pipe, the auto tripping ball seat **60** with release collet arms **120** at the initial position may be inserted into the well bore so as to engage the release collet arms **120** upon the bridging pipe as illustrated in in Figure **11**. Thereafter an upward force may be applied to the auto tripping ball seat **60** so as to pull upwardly on the bridging pipe **16**.

25 Thereafter, this movement caused by the pressurized working string along with an upward force applied to the top end of the work string will further engage the retrieval collet arms **120** in the bridging pipe and pull it upwardly out of the well bore. The upward motion of the bridging pipe **16** will initially shear the larger set screw **34** securing the bottom cone on bridging pipe to release this cone therefrom. The bridging pipe includes first second and third
30 retrieval rings **124**, **126** and **128**, respectively each adapted to engage and pull upwardly on the topmost cone, the top collet arm and bottom collet arm,

-18-

5 respectively. The upward motion of the bridging pipe thereafter will engage the first second and third retrieval rings **124**, **126** and **128** in order thereby removing the cones **25** and collet arms **20** in sequence. Advantageously, the first second and third retrieval rings **124**, **126** and **128** are positioned around the bridging pipe so as to engage the top cone first, the top collet second and the bottom collet third so as to space such components along the bridging pipe as they are pulled out of the well.

10 After the top collets and seal have been released, the bottom collets and seals may then also be released. If the larger set screw **32** has not yet been sheared by thermal cycling of the upward motion of the bridging pipe **16** will then shear such set screw. Optionally the larger set screw **32** may be received within a slot **130** in the bridging pipe so as to permit the larger set screw **32** to be sheared at a different time than the larger set screw **34** above so as to reduce the total force required. Similar to the top collets and seal above, the bridging pipe **16** includes first and second retrieval rings **132** and **134** respectively for pulling upwardly on the topmost collet arms as well as upwardly on the bottom most cone. The bridging pipe also includes a compression sleeve **140** between the topmost cone and the seal **24**. The compression sleeve **140** comprises inner and outer arms **144** and **142**, respectively interlocked with each other. The bridging pipe **16** includes a recess **146** just below the interlock such that upward movement of the bridging pipe permits the inner arms to radially move inward and therefore out of engagement with the outer arms. This will then permit the compression sleeve **140** to compress and therefore permit the topmost cone to slip downwardly out from under the collet arms thereby disengaging them from the well bore. As set out above, the first and second retrieval arms **132** and **134** are spaced apart by a distance to space all components along the bridging pipe.

30 As illustrated in Figure **2** and described above, the inner pipe assembly **80** bridges the bottom portion of the present apparatus to the top portion so as to transmit movement therebetween as set out above. The inner pipe assembly

-19-

5 **80** comprises a first pipe **500** extending from a bottom pipe base **502** adapted to form an inner base for the release apparatus **90**. The first pipe **500** extends to a distal end having an end assembly **502** thereon. The end assembly comprises an end collar **504** and a selectably releasable tag ring **506** releasably secured to said end assembly within the first pipe **500**. As illustrated in Figure **26**, the tag ring **506** includes a plurality of radially extending pins **508** therefrom which are adapted to be engaged within j-shaped slots **509** in the end collar **504** and rotated therein so as to secure the tag ring therein.

10

The inner pipe assembly **80** also includes a second pipe **510** extending from the auto tripping ball seat **60**. As illustrated in Figure **4**, the second pipe **510** is secured to the auto tripping ball seat **60** by top and bottom connectors **512** and **514** respectively. In operation the top and bottom connectors may have one or more pipe sections therein so as to space the second pipe away from the auto tripping ball seat **60** by a distance required to bridge the compromised well casing section. The second pipe **510** includes a plurality of grooves **516** around an exterior surface thereof stepped so as to permit movement of the end collar **504** in a direction towards the first end **12** of the assembly **10** only. As illustrated in Figure **25**, the end collar **504** includes a corresponding indexed ring **520** therein adapted to engage upon the grooves **516** so as to permit such movement only. As illustrated in Figure **25**, the tag ring **506** includes an entrance end having a profile defined by a series of rectangular blocks or castellations **530** therearound. The distal end of the second pipe **532** includes a corresponding end surface so as to be engageable therein.

15

20

25

In operation, as illustrated in Figure **23**, the bottom assembly comprising the bottom seal, bottom seal activation assembly **400** and first pipe **500** along with the end assembly **502** is located within a well bore. Thereafter, a plurality of pipes are secured thereto to form the bridging pipe **16** of a desired length. The second pipe **510** along with the stinger tube **540** may be introduced into the bore and inserted until the distal end **532** of the second pipe **510** engages

30

upon the tag ring **506** to confirm matching lengths of the inner pipe assembly **80** and bridging pipe **16**. It will be appreciated that a number of pipes may be located between the top and bottom connectors **512** and **514** to provide the desired length. Thereafter, the top assembly may be completed as illustrated in Figure **24**, comprising the setting tool **40**, auto tripping ball seat **60** and second pipe **510** along with the stinger tube **540** and reinserted into the well until the distal end **532** of the second pipe **510** encounters the tag ring **506**. Thereafter the top assembly may be rotated to engage the castellations in the second pipe with the corresponding castellations in the tag ring and thereafter rotating the tag ring **506** such that the pins **508** out of the j-shaped slots **509** so as to permit the second pipe **510** to pass therethrough. The top assembly may then be further inserted therein to complete the bridging pipe **16** at which point the completed assembly **10** may be inserted in to the well bore to the desired location. As illustrated in Figure **17**, the slidable member **60** and collet arms **66** may be positioned to cover a release hole **440**. When the slidable member **60** is shifted downwards as set out above, the release hole **440** may be positioned to be uncovered so as to fluidically connect the interior of the assembly with the annulus thereby preventing pressure build up from removing the assembly from the well bore.

As utilized herein “pipe” shall be defined to include at least one pipe section which may be connected to additional pipe sections of commonly provided lengths which may be joined in any conventional means such as, by way of non-limiting example, welding, couplers or pipe joints as are commonly known. As utilized herein castellation shall be used to describe an end surface of a pipe or other body having a series of rectangular notched indented portions.

While specific embodiments of the invention have been described and illustrated, such embodiments should be considered illustrative of the invention only and not as limiting the invention as construed in accordance with the accompanying claims.

The embodiments of the invention in which an exclusive property or privilege is claimed are defined as follows

1. An apparatus for bridging a section of ruptured casing within an oil well comprising:

a length of bridging pipe extending between first and second ends sized to be located within the casing so as to span the section of ruptured casing;

a first seal located around said bridging pipe proximate to said first end thereof;

a second seal located around said bridging pipe proximate to said second end thereof,

wherein said second seal comprises;

top second seal collet arms extending downwardly from a top collet retaining ring disposed around said bridging pipe, said top second seal collet arms extending to distal ends having outwardly oriented pipe engagement surfaces;

top and bottom second seal cones positioned below said top second seal collet arms around said bridging pipe;

a second seal element extending around said bridging pipe between said top and bottom second seal cones;

bottom second seal collet arms extending upwardly from a bottom collet retaining ring disposed around said bridging pipe, said bottom second seal collet arms extending to distal ends having outwardly oriented pipe engagement surfaces; and second seal engagement sleeve surrounding said bridging pipe proximate to said second end thereof;

an installation assembly extending through said bridging pipe operably engaged with said first and second ends of said bridging pipe, wherein said installation assembly is operable to extend each of said first and second seals into engagement with said oil well and wherein said installation assembly is further operable to selectably disengage from said bridging pipe.

2. The apparatus of claim 1 wherein said first seal comprises:
 - top and bottom first seal collet arms extending away from a first seal retaining ring disposed around said bridging pipe, each of said top and bottom first seal collet arms extending to distal ends having outwardly oriented pipe engagement surfaces;
 - top and bottom first seal cones positioned adjacent to said distal ends of said top and bottom first seal collet arms around said bridging pipe;
 - first seal engagement sleeve surrounding said bridging pipe proximate to said first end thereof; and
 - a first seal element extending around said bridging pipe between said top first seal cone and said first seal engagement sleeve.
3. The apparatus of claim 2 wherein said first seal retaining ring, said top first seal cones and said first seal engagement sleeve are temporarily secured to said bridging pipe with shear pins.
4. The apparatus of claim 3 wherein said shear pins securing said first seal retaining ring, said top first seal cones and said first seal engagement sleeve are sheared in order from top to bottom as said bridging pipe moves therethrough.

5. The apparatus of claim 3 wherein said first seal retaining ring, said top first seal cones and said first seal engagement sleeve are removed from engagement with the oil well by retrieval rings adapted to engage thereupon.
6. The apparatus of claim 5 wherein said first seal retaining ring, said top first seal cones and said first seal engagement sleeve are engaged upon in order from top to bottom by said retrieval rings.
7. The apparatus of claim 1 wherein said top collet retaining ring, said top and bottom second seal cones, said bottom retaining ring and said second seal engagement sleeve are temporarily secured to said bridging pipe with shear pins.
8. The apparatus of claim 7 wherein said shear pins securing said top collet retaining ring, said top and bottom second seal cones, said bottom retaining ring and said second seal engagement sleeve are sheared in order from bottom to top as said bridging pipe moves therethrough.
9. The apparatus of claim 7 wherein said shear pin securing said top collet retaining ring is sized larger than said shear pins securing said top and bottom second seal cones, said bottom retaining ring and said second seal engagement sleeve.
10. The apparatus of claim 1 wherein said top collet retaining ring, said top and bottom second seal cones, said bottom retaining ring and said second seal engagement sleeve are removed from engagement with the oil well by retrieval rings adapted to engage thereupon.
11. The apparatus of claim 10 wherein said top collet retaining ring, said top and bottom second seal cones, said bottom retaining ring and said second seal engagement sleeve are engaged upon in order from top to bottom by said retrieval rings.

12. The apparatus of claim 1 further comprising a selectably compressible sleeve between said top second seal cone and said second seal element.

13. The apparatus of claim 12 wherein said selectably compressible sleeve comprises a plurality of release arms extending from a sleeve adjacent to said second seal element, said plurality of release arms having end surfaces selectably engageable with a corresponding receptacle sleeve extending from said top second seal cone, wherein said end surfaces of said release arms are maintained in engagement with said receptacle sleeve by said bridging pipe, wherein said receptacle sleeve is located at a position along said bridging pipe corresponding to a position at which said release arms are desired to be released from engagement with said receptacle sleeve.

14. The apparatus of claim 1 wherein said bridging pipe includes a plurality of longitudinal slots extending therealong and further including a carriage within each slot in engagement with said second seal engagement sleeve so as to transmit longitudinal movement of a tool inside said bridging pipe to said second seal engagement sleeve.

15. A method for bridging a section of pipe casing having a compromised section comprising:

providing a length of bridging pipe extending between first and second ends located within the casing so as to span the compromised section;

locating an installation assembly within said bridging pipe;

positioning said bridging pipe within said pipe so as to span said compromised section;

with said installation assembly, longitudinally compressing said first end of said bridging pipe so as to extend a first seal therearound located proximate to said first end of said bridging pipe;

releasing said installation assembly from said first end of said bridging pipe;
with said installation assembly, longitudinally compressing said second end of
said bridging pipe so as to extend a second seal therearound located proximate to
said second end of said bridging pipe;

wherein said second seal comprises;

top second seal collet arms extending downwardly from a top collet retaining ring
disposed around said bridging pipe, said top second seal collet arms extending to
distal ends having outwardly oriented pipe engagement surfaces;
top and bottom second seal cones positioned below said top second seal collet
arms around said bridging pipe;

a second seal element extending around said bridging pipe between said top and
bottom second seal cones;

bottom second seal collet arms extending upwardly from a bottom collet retaining
ring disposed around said bridging pipe, said bottom second seal collet arms
extending to distal ends having outwardly oriented pipe engagement surfaces; and
second seal engagement sleeve surrounding said bridging pipe proximate to said
second end thereof;

releasing said installation assembly from said second end of said bridging pipe;
removing said installation assembly from said bridging pipe.

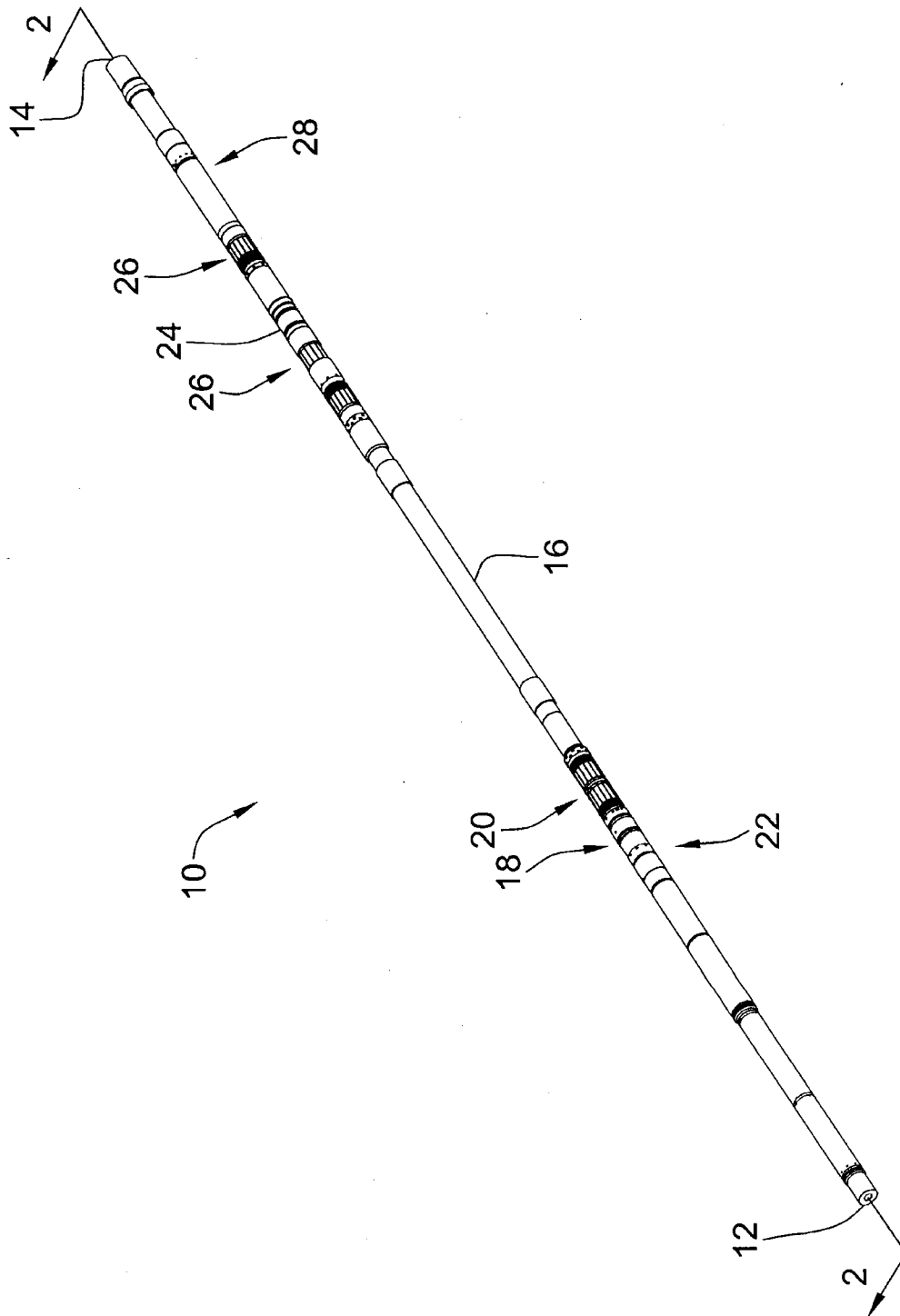

Figure 1

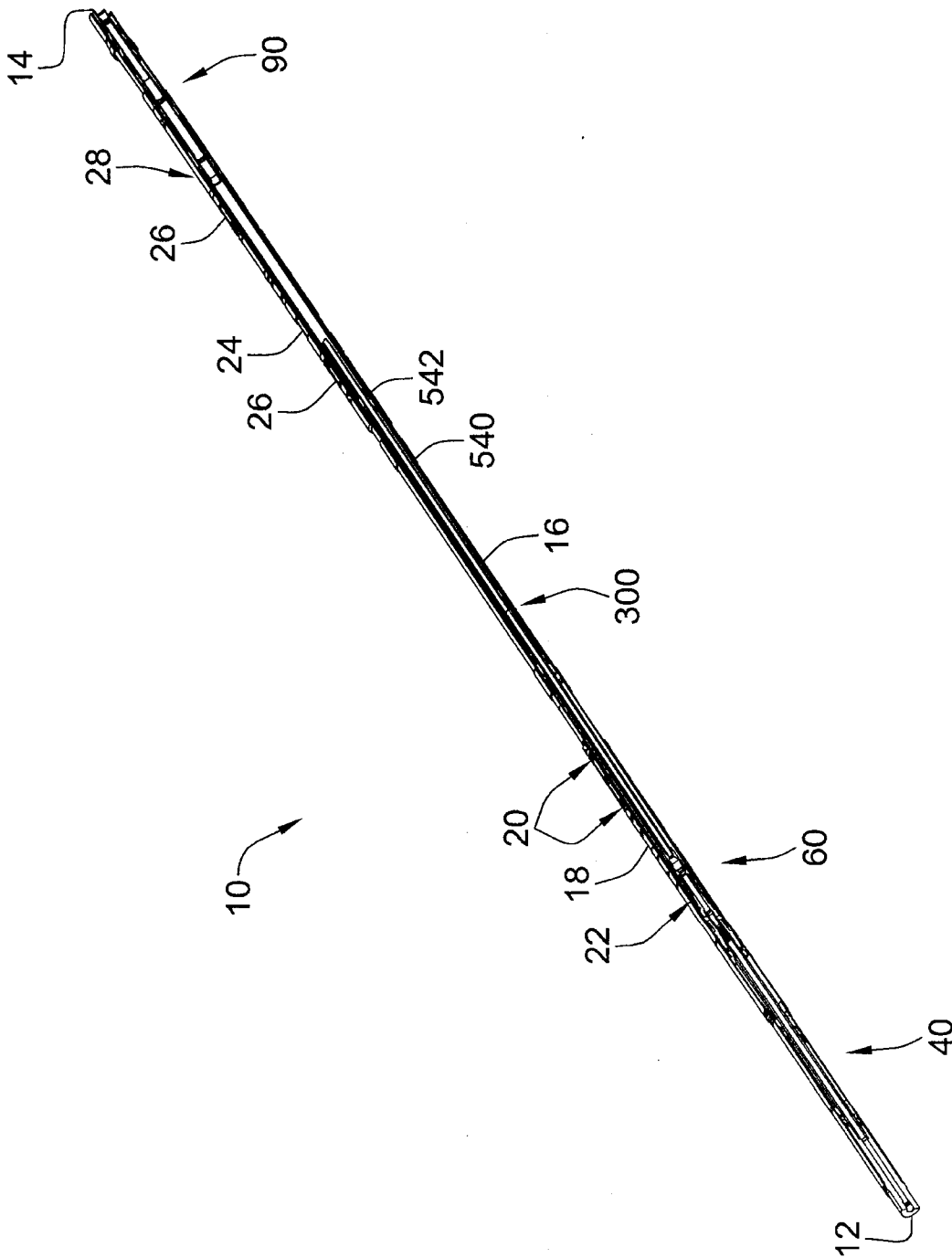

Figure 2

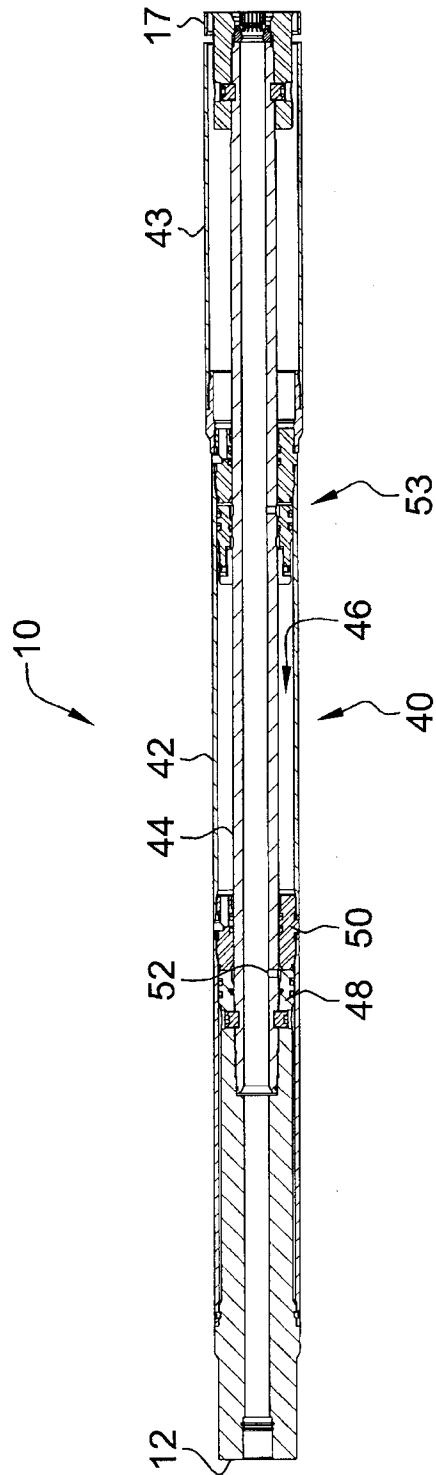

Figure 3

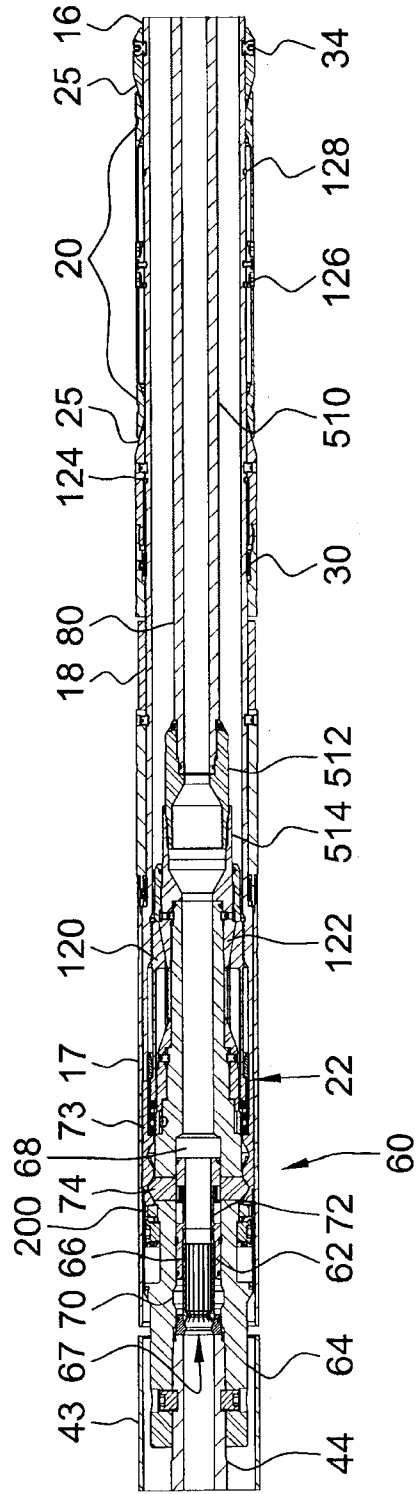

Figure 4

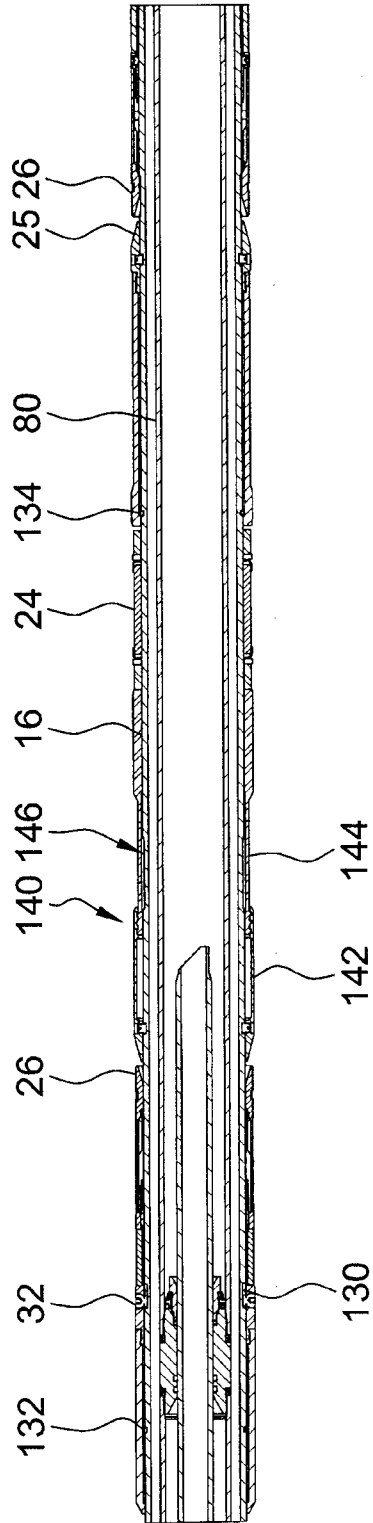

Figure 5

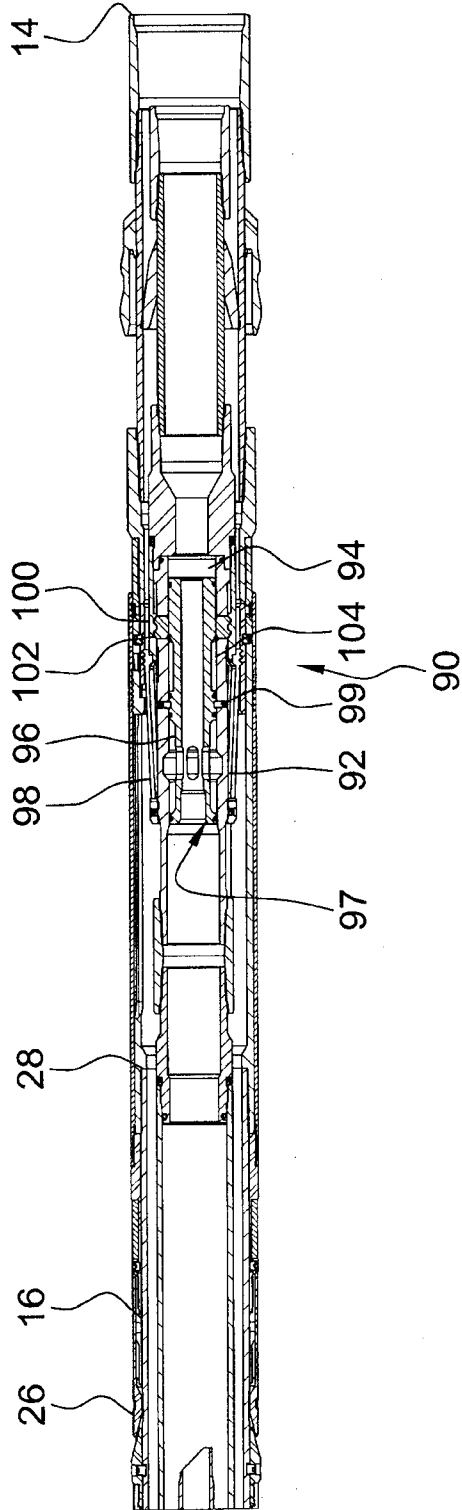
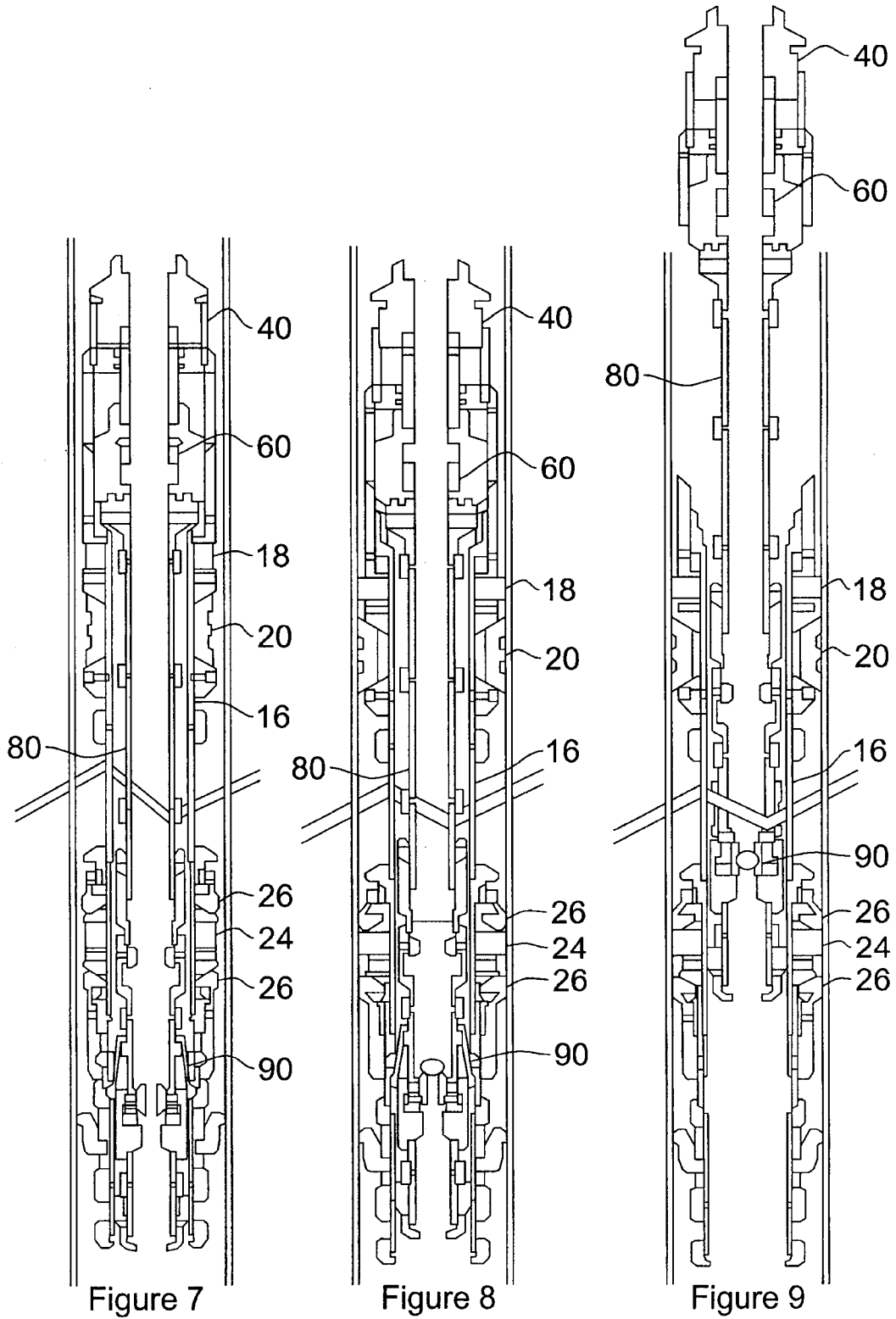

Figure 6



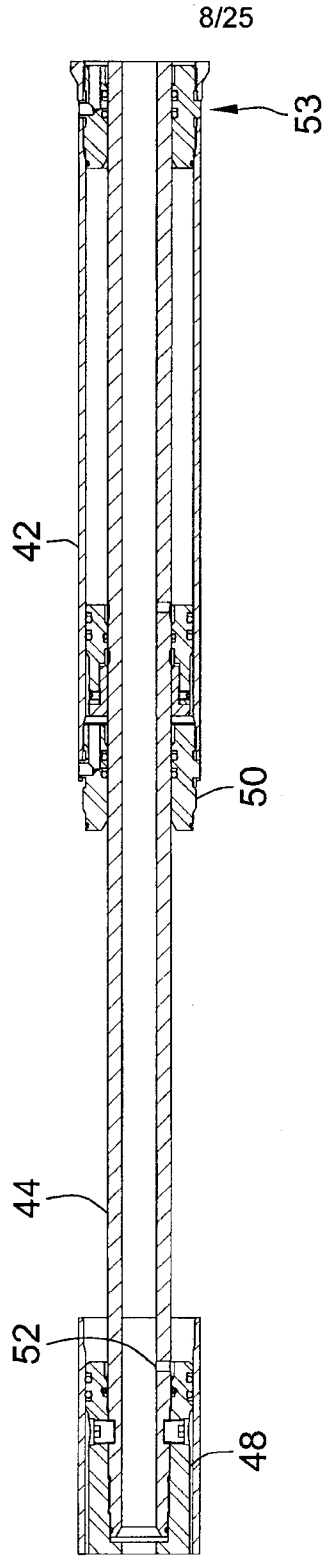

Figure 10

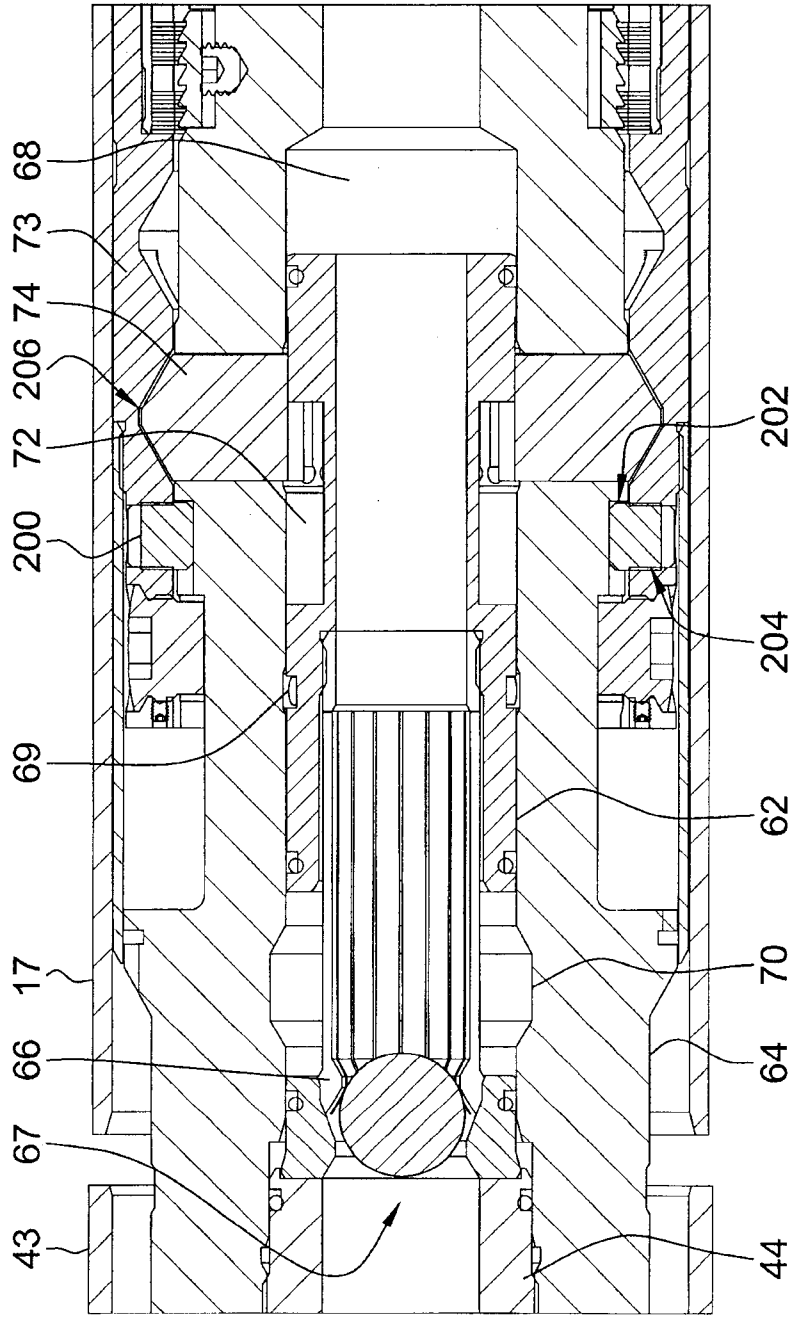

Figure 12

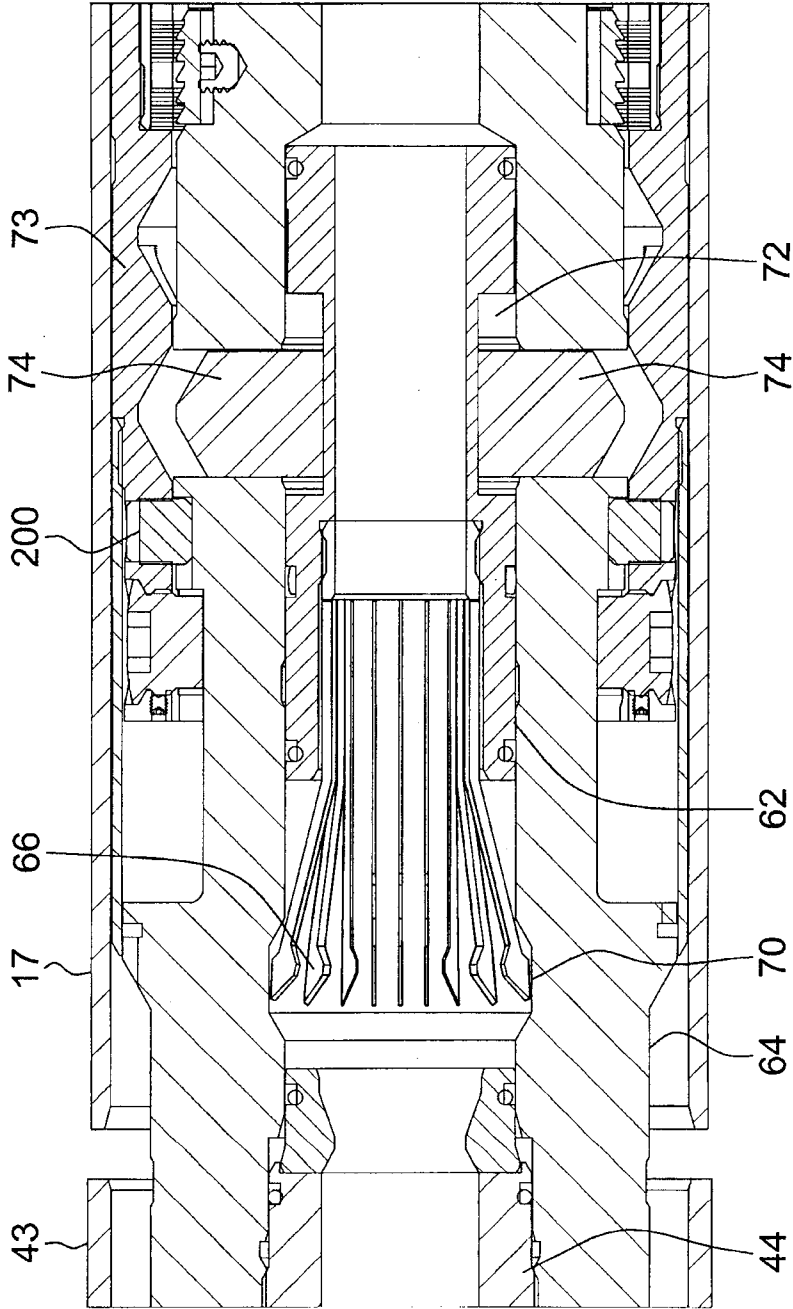

Figure 13

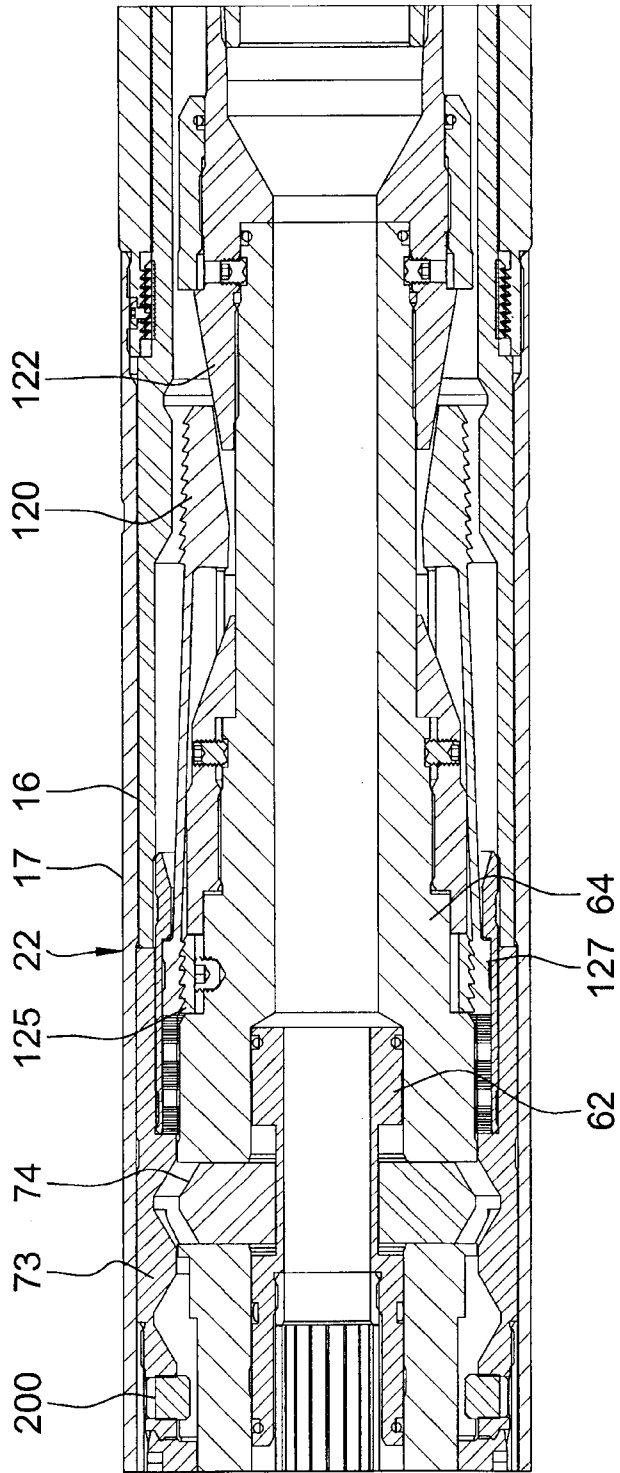

Figure 14

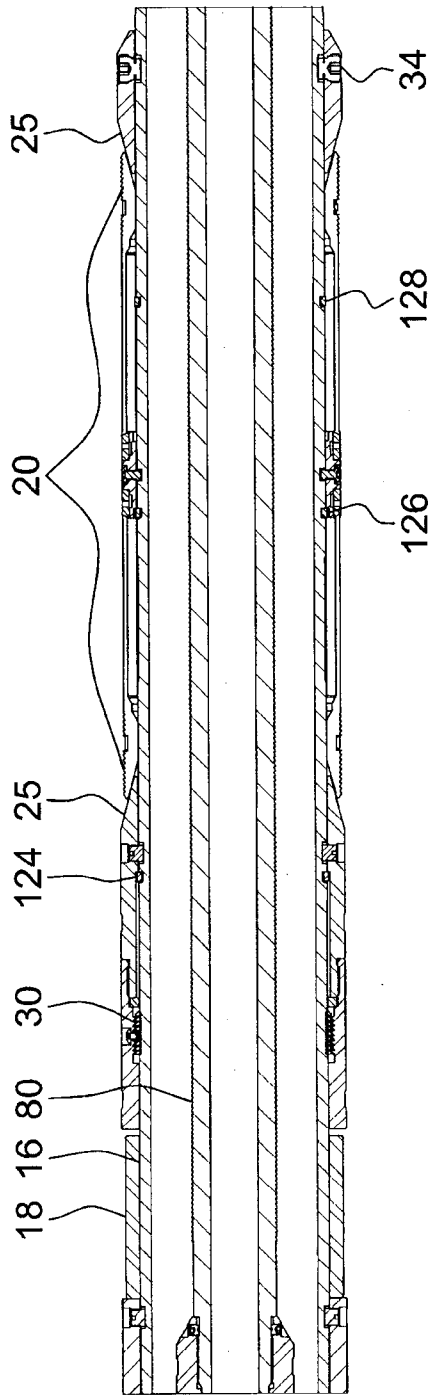

Figure 15

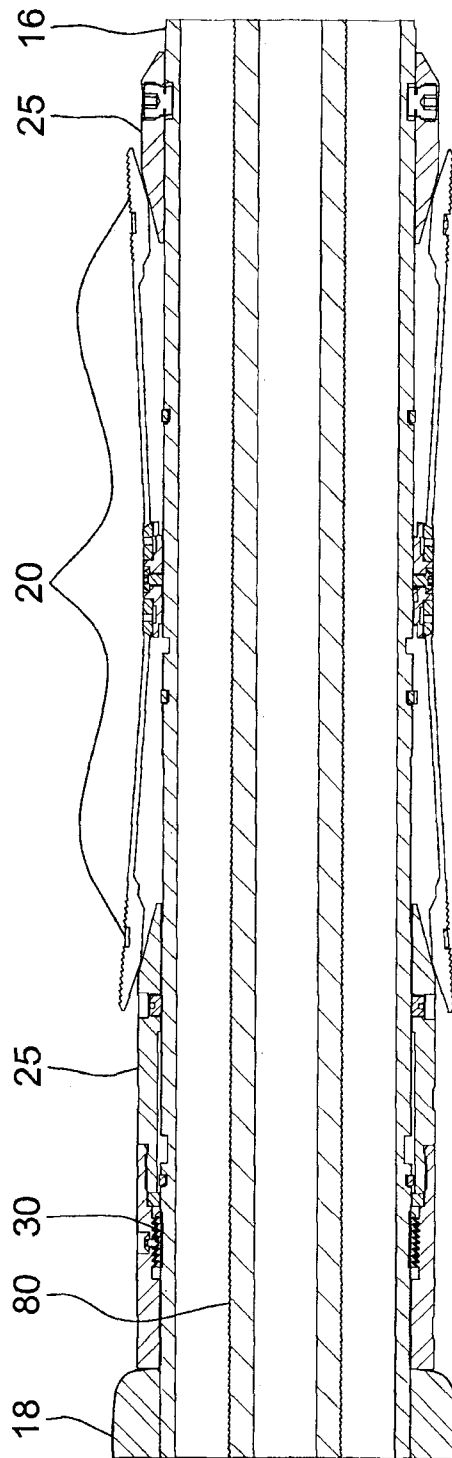

Figure 16

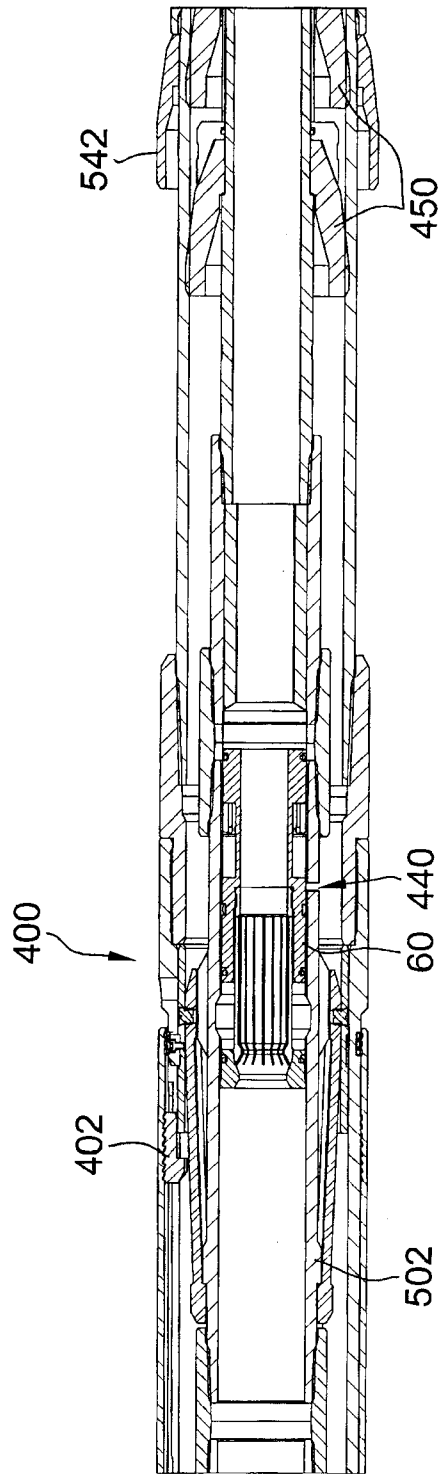

Figure 17

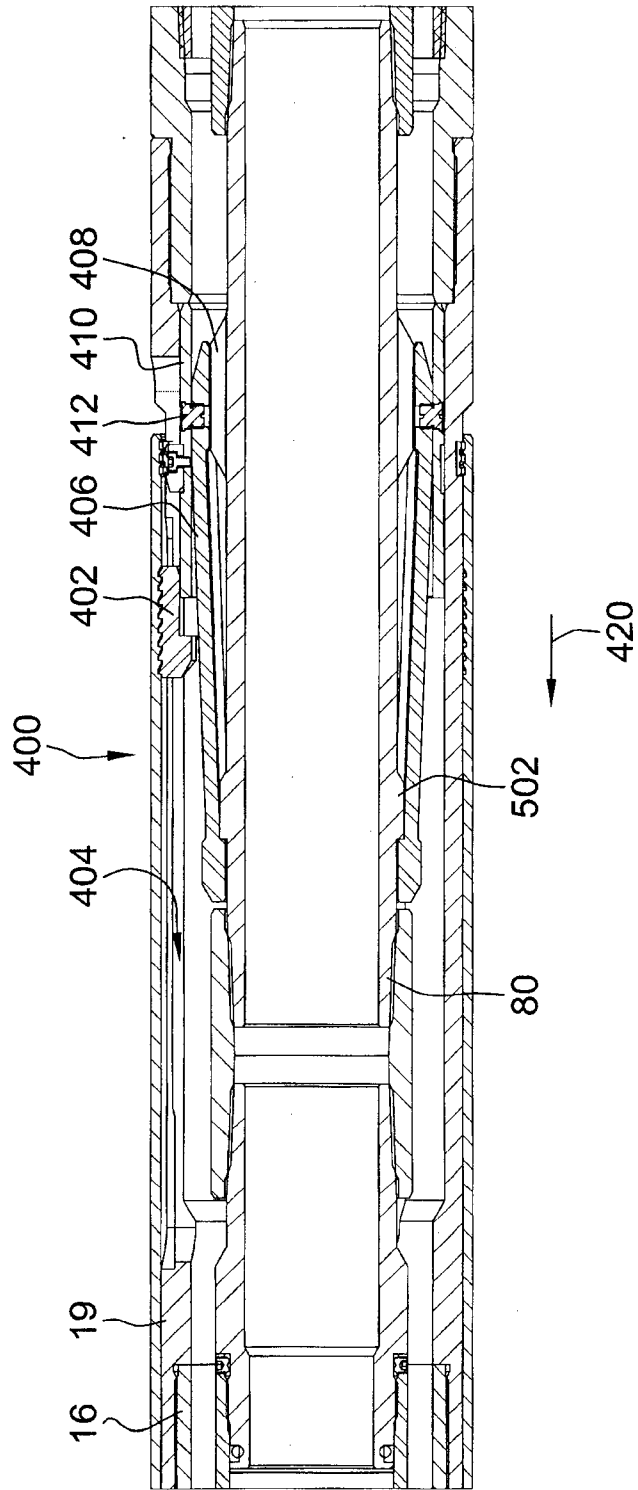

Figure 18

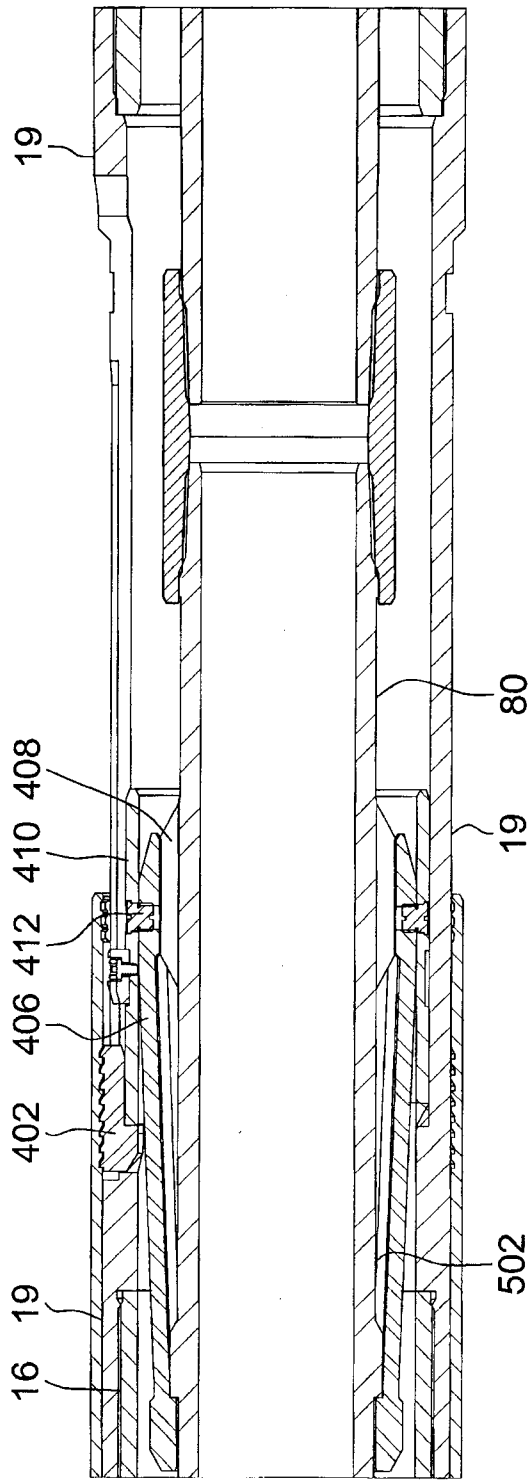

Figure 19

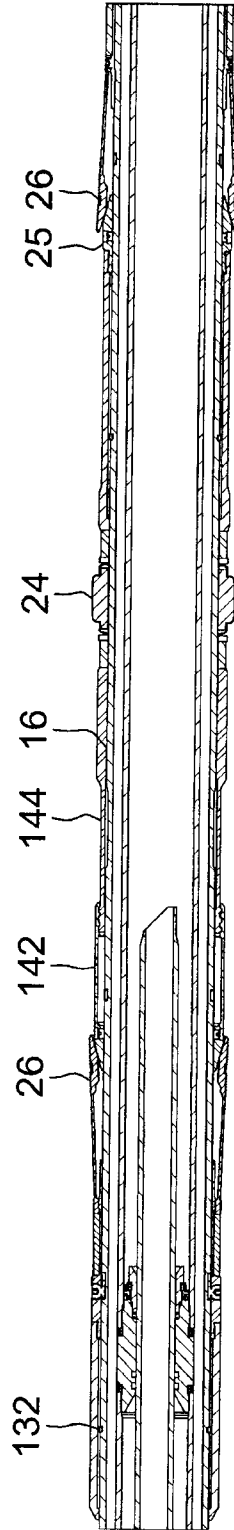

Figure 20

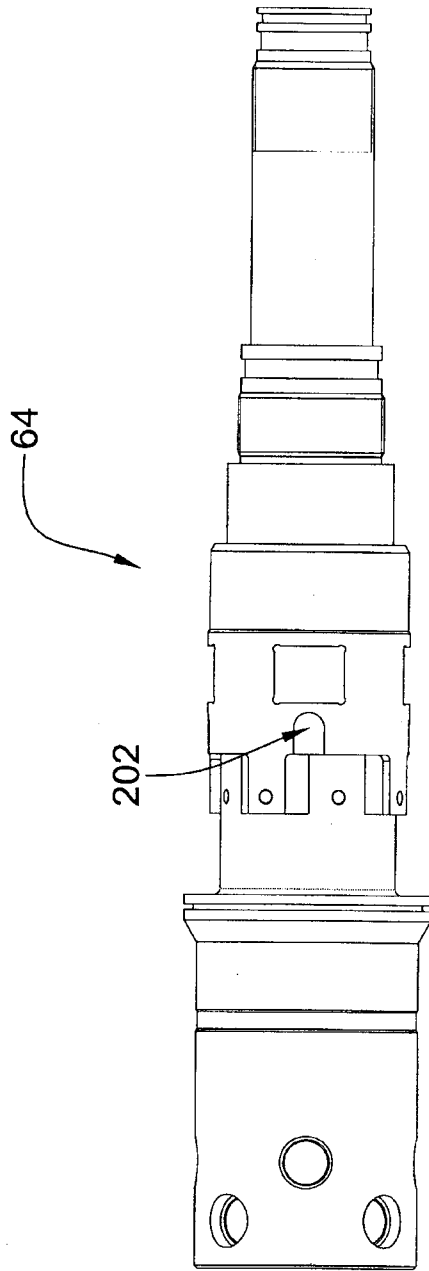

Figure 21

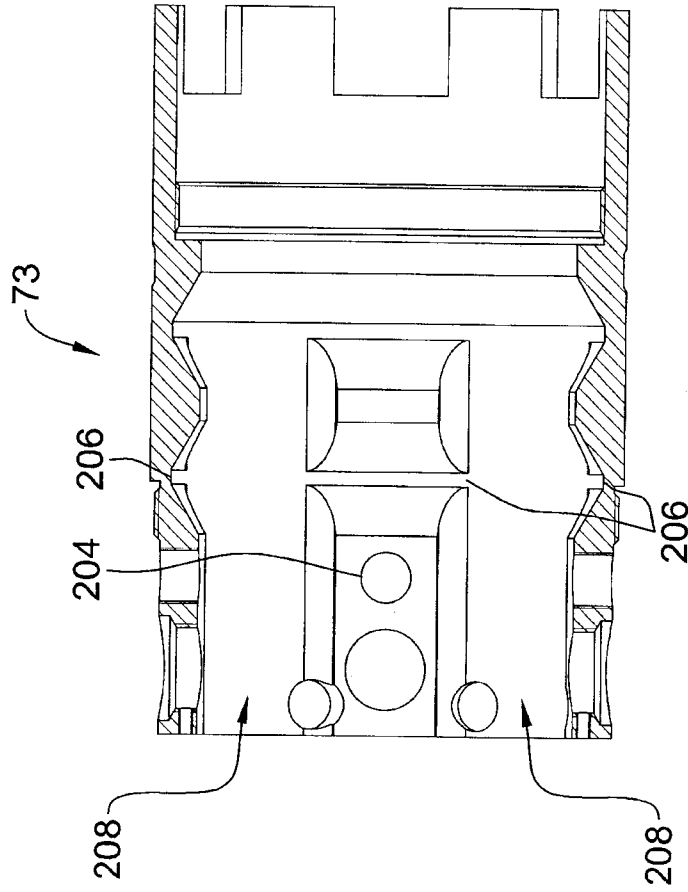

Figure 22

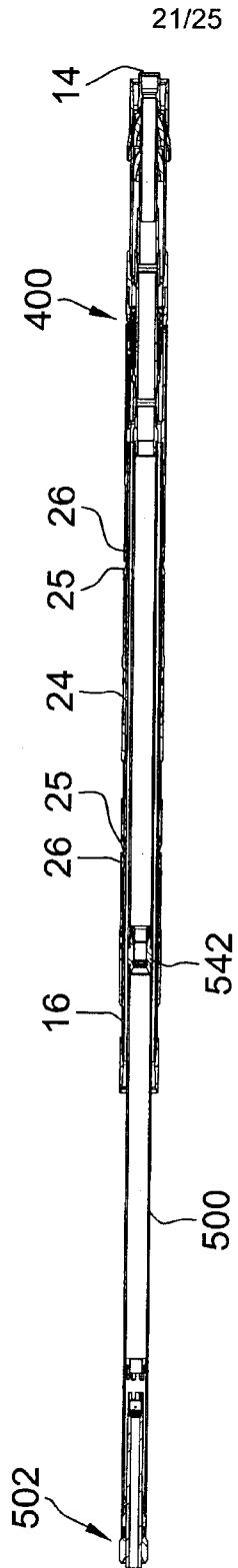

Figure 23

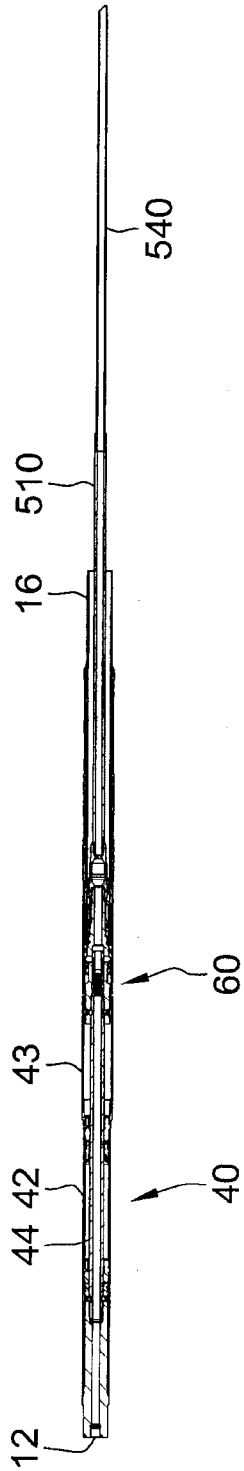

Figure 24

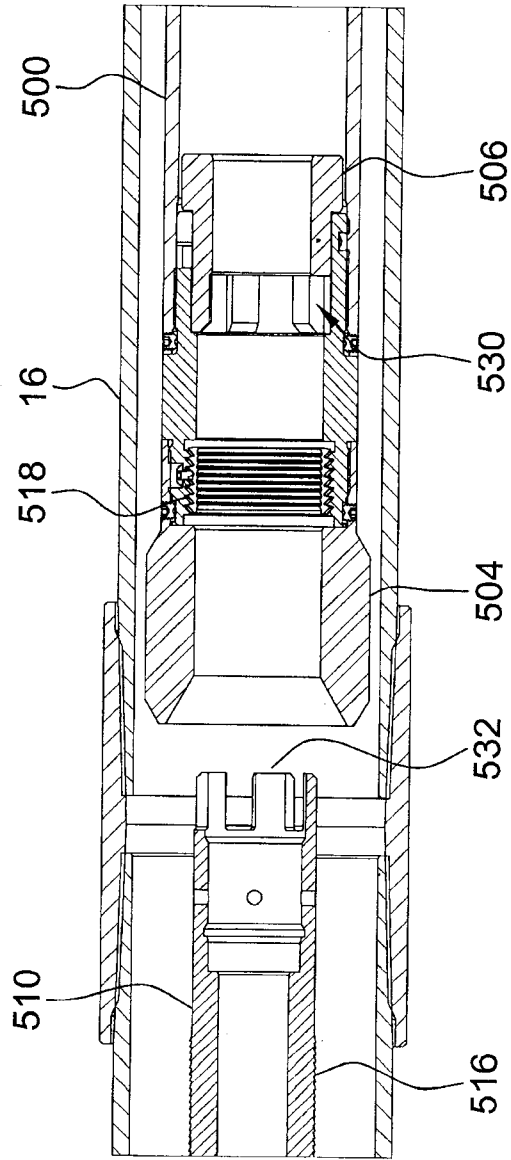

Figure 25

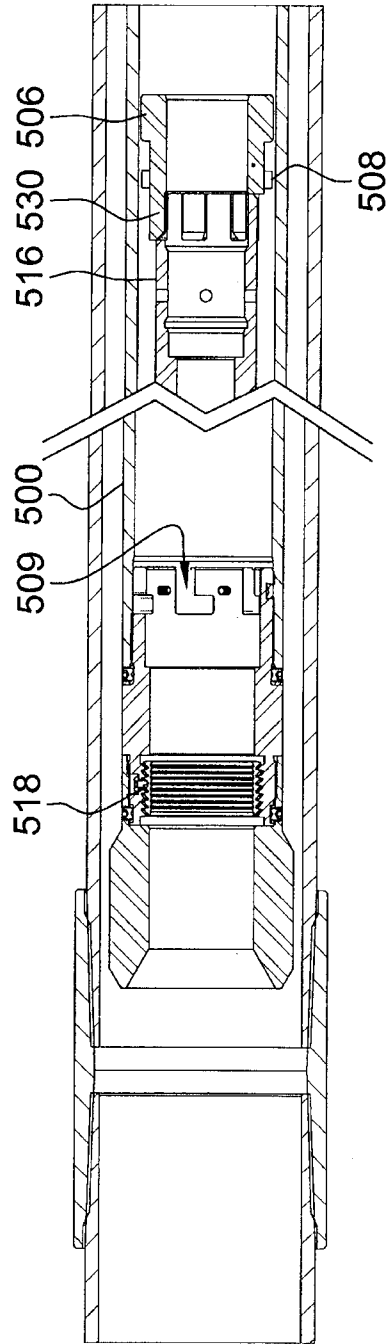

Figure 26

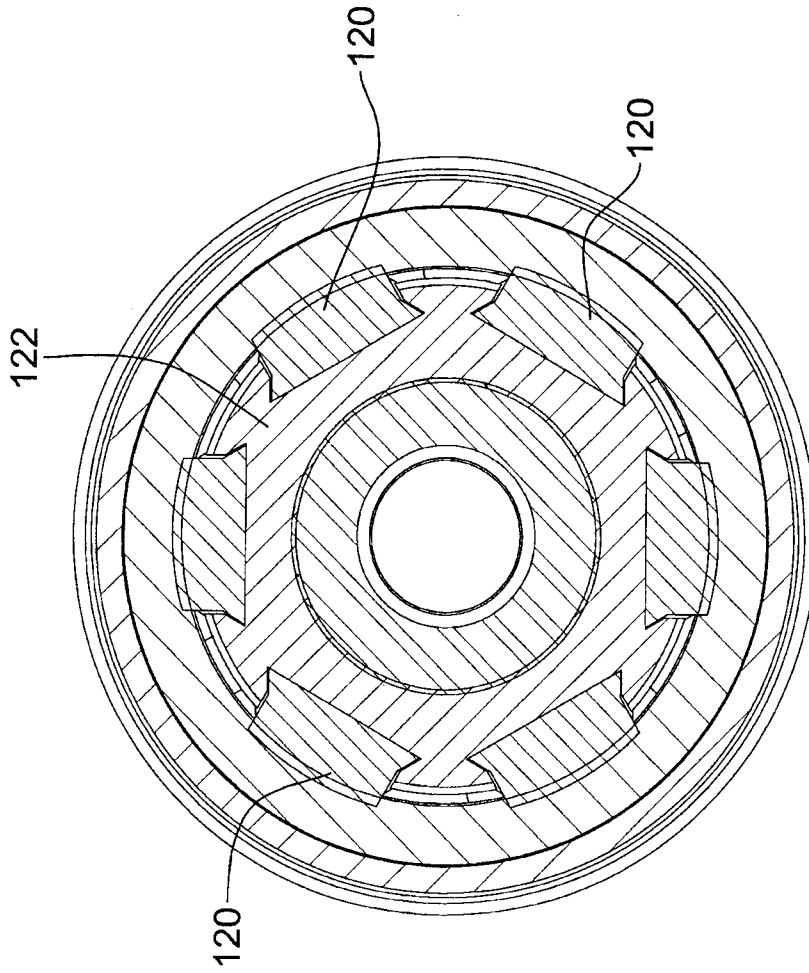

Figure 27

