

(No Model.)

Z. L. PALMER.
WAGON JACK.

No. 500,940.

Patented July 4, 1893.

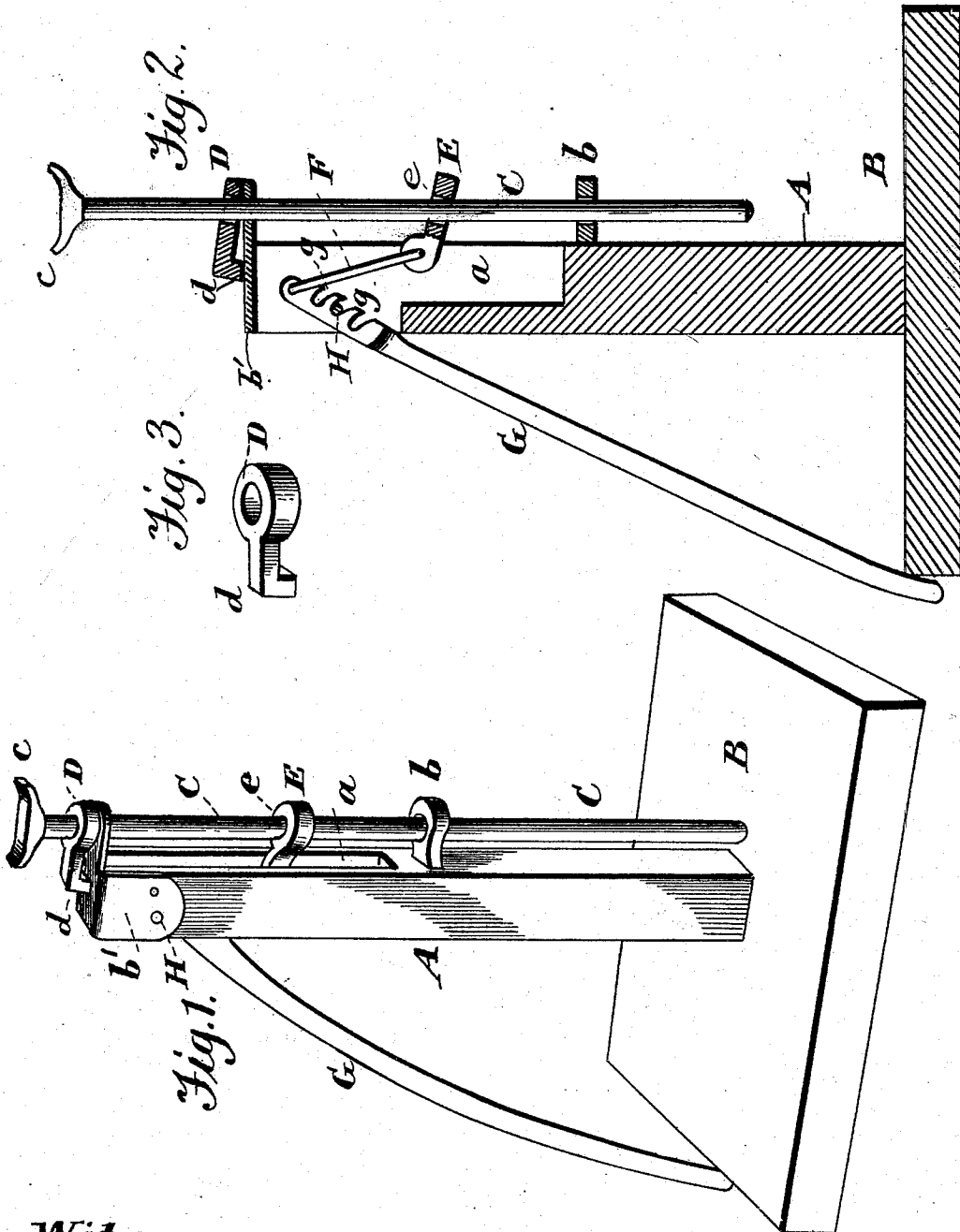

Witnesses.
A. Ruppert,
G. M. Loebkaver

Inventor.
Zenas L. Palmer,
Per
Thomas P. Simpson
Atty

UNITED STATES PATENT OFFICE.

ZENAS LEONARD PALMER, OF BAY PORT, MICHIGAN, ASSIGNOR TO
H. H. GOULD, OF SAME PLACE.

WAGON-JACK.

SPECIFICATION forming part of Letters Patent No. 500,940, dated July 4, 1893.

Application filed March 29, 1893. Serial No. 468,104. (No model.)

To all whom it may concern:

Be it known that I, ZENAS LEONARD PALMER, a citizen of the United States, residing at Bay Port, in the county of Huron and State of Michigan, have invented certain new and useful Improvements in Wagon-Jacks; and I do declare the following to be a full, clear, and exact description of the invention, such as will enable others skilled in the art to which it appertains to make and use the same, reference being had to the accompanying drawings, and to the letters of reference marked thereon, which form a part of this specification.

The special object of the invention is to make a wagon jack which can be operated with a very slight muscular exertion on the part of the wagoner by one or more lifts.

The invention will first be described in connection with the drawings and then pointed out in the claim.

Figure 1 of the drawings is a perspective view of my wagon jack with the axle-lifter rod down, resting on the base; Fig. 2 a median vertical section, with the lifter raised and held up by the clutch, and Fig. 3 a detail view of the stop or retaining clutch.

In the drawings, A represents a perpendicular post supported in the middle of the base B and provided with the vertical slot *a*. Below this slot is fastened the eyeplate *b* and above it the eyecap *D'*, in both of which, as guides, slides the lifter rod C—preferably having at the top a concave holder to receive the axle. Between the holder *c* and the cap *b'*, I arrange the clutch D through which loosely passes the lifter rod C at one end, while at the other is a leg *d* at right angles thereto. When this leg rests on the cap, the rod C may rise through it without resistance as the eye of the clutch rises to a horizontal position, but

as soon as the rod moves downward, the clutch rests on the cap at an angle and will prevent the rod from moving downward.

E is the lifting clutch having at one end the eye *e* and pivoted at the other to a loop F whose upper end is jointed to the front end of a lever G. This lever is provided with the notches *g* on the under side of the front end and in these notches fits the fulcrum pin H extending across the slot *a*. By changing the fulcrum of the lever, a better leverage may be obtained according to the weight to be lifted, while if the first lift has not raised the axle to the desired height, the clutch E may be moved down on the rod C while the clutch D retains it in position and another lift is taken. When it is desired to let the axle down, turn the clutch D until its leg *d* is off the cap, and raise the lever until the wheels of the axle rest on the ground.

Having thus described all that is necessary to a full understanding of the invention, what I claim as new, and desire to protect by Letters Patent, is—

In a lifting jack, the lever G having under its front end a series of fulcrum notches *g*, in combination with a lifting-clutch connected with said lever by a pivoted loop, a post having the slot *a*, the cross-pivot H in said slot and guide-eyes on the same side, a rod movable in said guide-eyes and adapted to support the weight to be lifted, and a loose detent clutch for the top of the post, all substantially as shown and described.

In testimony whereof I affix my signature in presence of two witnesses.

ZENAS LEONARD PALMER.

Witnesses:

FARLEY CRAW,
CHAS. F. CRAW.