

Dec. 18, 1962

E. C. HART
PRINT DRIER

3,069,002

Filed April 26, 1960

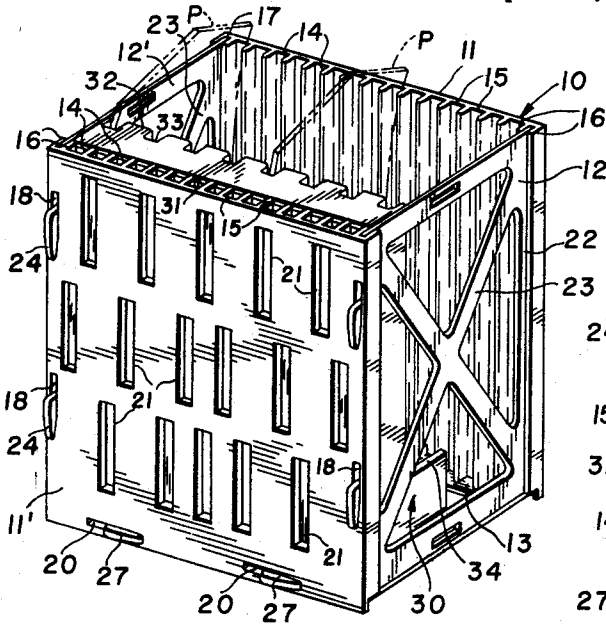

FIG. 1

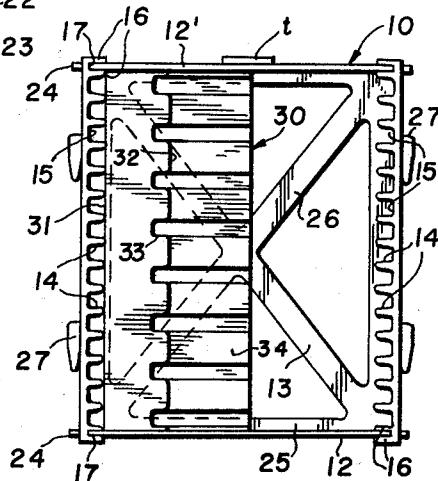

FIG. 4

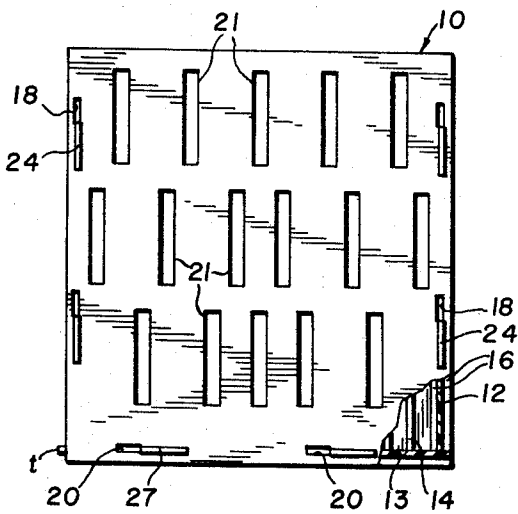

FIG. 2

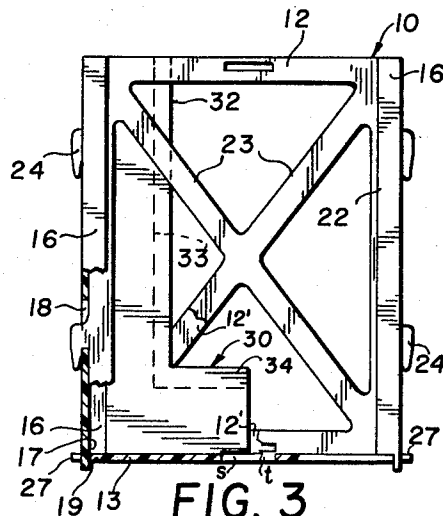

FIG. 3

INVENTOR.

EDWIN C. HART

BY

Green, McCallister & Miller

ATTORNEYS

1

3,069,002

PRINT DRIER

Edwin C. Hart, 513 Wimer Circle, Pittsburgh 37, Pa.

Filed Apr. 26, 1960, Ser. No. 24,723

6 Claims. (Cl. 206—1)

This invention relates to a drier for positioning a plurality of prints in a spaced-apart relationship to facilitate the drying thereof, and more particularly to a cross-ventilated, collapsible, and easily portable print drier.

The recent development in the photographic art of the self-developing camera, such as disclosed in U.S. Patents Nos. 2,435,717, 2,435,718, 2,435,719, 2,455,111, and 2,543,160, now make it possible for an individual to take a picture and receive the developed print in a matter of minutes. However, in order to preserve such a print, it is necessary to apply a special preservative, such as a prepared wax coating, to the surface of the print. This coating must then be dried before the surface of the print is allowed to come in contact with another object, or the picture may become smeared or disfigured. Accordingly, after the wax coating is applied to the surface of the picture, it is necessary that the print having the wet coating be very carefully handled in order to avoid contact with foreign objects.

In the past, I have found that such wet coated prints, when merely placed on a table or other flat surface while waiting for the preservative to dry, have become disfigured by an object inadvertently being set on top of it, or they have been blown off the table and against another object by an ambient breeze, thus disfiguring the picture. It therefore, becomes incumbent upon the photographer to hold the print by the edges during the drying operation in order to prevent the picture from coming into contact with other objects. However, even an inadvertent contact of the print with the hand will smear or mar the finish of the picture when in a wet condition. Further, holding the print by hand during the drying period is cumbersome if not tedious.

Accordingly, I have devised a new and improved inexpensively constructed and easily collapsible portable print drier, specifically designed to accommodate the various size prints which are produced by the known self-developing cameras. A plurality of opposed grooves formed along inner surface portions of the drier position the prints in a spaced-apart and well ventilated relationship to facilitate drying. The drier is preferably formed of light-weight plastic members having slide-in-and-out interlocking tongue and groove portions, so that the various members may be quickly and easily assembled for use and disassembled for portability.

It thus has been an object of my invention to provide a simple solution to the print drying problems which heretofore plagued the user of the self-developing type of camera;

A further object of my invention has been to provide an inexpensively manufacturable print drier which may easily be collapsed or disassembled when not in use for compactness and ease in portability;

An additional object of my invention has been to provide a print drier which may easily be adapted to accommodate the various size prints which are produced by the known types of self-developing cameras;

These and other objects of my invention will be apparent to those skilled in the art from the following disclosure and accompanying drawings in which:

FIGURE 1 is a perspective view illustrating a now preferred embodiment of my collapsible print drier showing an adapter positioned therein for accommodating small size prints;

FIGURE 2 is a side elevational view of a print drier

2

embodying my invention with the lower right-hand corner of the side member cut away to show the rib and groove connections between the end and side members;

FIGURE 3 is an end elevational view of the print drier shown in FIGURE 1 with the lower left-hand corner cut away to show the tab connections between the end members with the side members and the bottom member; and,

FIGURE 4 is a top plan view of the print drier shown in FIGURE 1.

An assembled print drier or box 10 comprises a pair of opposed side members or vertical side walls 11 and 11', a pair of opposed end members or vertical side walls 12 and 12', and a bottom member or wall 13. The side members 11 and 11' are identical with one another and have a plurality of inwardly-extending guide rails or flanges 14 forming spaced-apart print-receiving grooves 15 therebetween. The grooves 15, formed in the side members 11 and 11', are shown as diametrically or cooperatively opposed to one another so that a pair of such opposed grooves may receive opposite edge portions of a print to retain it in position within the drier. A plurality of vent slots 21 are formed through each of the side members, so that at least one such slot communicates with each of the grooves 15 for facilitating cross ventilation adjacent each print positioned within a pair of the opposed print-receiving grooves 15.

A pair of end flanges 16, forming a recess 17 therebetween, extends inwardly from end portions of the side members. Each recess 17 is adapted to receive a side edge portion of an end member 12 or 12'. A pair of spaced-apart slits 18 are formed through the side members adjacent to and in communication with each of the recesses 17 to receive locking tabs formed on the end members. A horizontal groove 19 is formed adjacent the lower edge of each of the side members to slidably receive side edge portions of the bottom member 13 therebetween. A pair of horizontal slots 20 are formed through the side members in communication with the horizontal grooves 19 to receive locking tabs or lugs formed on the bottom member. As shown in FIGURES 1, 2 and 3, the bottom member 13 is held in an elevated position by outwardly extending flanges or support means that are formed integrally with the side members 11 and 11'.

The end members 12 and 12' and the bottom member 13 have identical constructions and may be interchanged. The end members 12 and 12' have a rectangular outer frame 22 strengthened by X-shaped cross supports 23. In a like manner, the bottom member 13 has a rectangular frame 25 strengthened by X-shaped cross supports 26. The end members 12 and 12' have a pair of vertically spaced-apart lugs or tabs 24 formed on each side thereof to project through the slits 18 formed in the side members 11 and 11'. Likewise, the bottom member 13 has a pair of spaced-apart tabs or lugs 27 which are adapted to interlockingly fit within the horizontal slits 20, formed adjacent the lower edge of the side members 11 and 11'.

The end members 12 and 12' and the bottom member 13 are each provided with slots *s* adjacent their opposite ends, and a tab *t* projecting outwardly from one end. As shown particularly in FIGURE 3, the tab *t* on the end members 12 and 12' projects downwardly within the slot *s* formed in the bottom member 13 to form an interlocking connection. The tab *t*, formed on the bottom member 13, merely projects outwardly a short distance, as shown in FIGURES 2 and 4, and has no utility in this particular position, however, the bottom member 13 may be interchanged with the side members 12 or 12' when assembling the collapsed members to form the drier, and then the tab *t* will form a connecting flange with the bottom member.

For ease in portability, the drier is usually carried in a collapsed or disassembled condition. When it is desired to utilize the drier, the ends, bottom, and side members are assembled by interlocking the various lugs or tabs within the slits. Since the end and bottom members are identical, the drier is composed of only two different members, which not only facilitates ease in assembly, but also ease and economy in manufacture. The drier 10 is easily assembled by merely positioning the bottom and end members within their respective grooves, formed in the side pieces, and securing them in position by lockably positioning the lugs or tabs through the cooperating slots formed adjacent thereto. As shown in the drawings, the lugs 24 and 27 are hook-shaped and have a recessed portion which receives a wall portion of the side members therewithin when the lugs are slid into a releasably locked position therewith.

After the various members are so assembled in a locked position, the print drier is ready to receive prints for drying. As a print is removed from a self-developing camera, it may be easily positioned within a pair of cooperating oppositely-disposed grooves 15 formed within the drier 10. When the camera is set aside and the preservative opened for use, the print P may then be removed from the drier and coated with the preservative, and again repositioned within the drier to allow the preservative to dry. A plurality of such prints P may be so positioned within the drier 10 which maintains the prints in a spaced-apart relationship and facilitates the drying of the preservative, without scratching, marring, or otherwise obliterating the picture. As shown in the drawings, the prints P are not only freely accessible to air from the top and bottom of the drier, but also a cross ventilation is provided by the vent slots 21 formed in the opposed side walls 11 and 11' adjacent the grooves 15. If desired, the prints may be temporarily stored within the print drier until they may be conveniently mounted. In addition, if desired, the integrally formed slots s adjacent the top of each of the ends 12 and 12' may be employed as support means that can be provided with a suitable handle (not shown) for carrying the print drier in an assembled position.

As shown particularly in FIGURES 1, 3 and 4, the print drier 10 may be provided with an L-shaped filler 30 to facilitate the positioning of small size prints. The filler 30 frictionally fits within the drier 10 and has a flat back wall 31 which abuts against the outer ends of the guide rails 14, and a bottom surface which rests upon the bottom member 13. The side ends of the filler 30 frictionally engage the end members 12 and 12' to retain it in position in the drier. The L-shaped filler 30 has an extended vertical leg, substantially equal to the height of the drier 10, and a short horizontal leg. A plurality of lands or guide rails 32, having a plurality of grooves 33 formed therebetween, extend vertically along a forward face of the vertical leg and horizontally along an upper surface 34 of the horizontal leg. The grooves 33, formed in the vertical leg, are diametrically opposed to the grooves 15 formed in an opposite side wall 11 or 11' of the drier, and cooperate therewith for the positioning of a small size print P therewithin.

The upper surface 34 of the short leg supports the bottom edge of the smaller size prints. The horizontal section of the grooves 33 cooperates with the opposed vertical grooves 33 and 15 to maintain the prints in a spaced-apart and well ventilated relationship. Although the filler 30 is shown as having a lesser number of grooves 33 than the grooves 15 in the side members, it is apparent that the number of grooves 33 formed in the filler may be equal to the number of grooves 15 formed in the opposed side wall 11 or 11'. When the filler 30 is incorporated within the drier 10, the drier is utilized in exactly the same manner as previously described without the filler; however, with the use of the filler, small prints may be adequately positioned within the drier.

Although I have set forth a preferred embodiment of my invention, it will be apparent to those skilled in the art that various changes and modifications may be made hereto without departing from the spirit and scope of the invention as set forth in the appended claims.

I claim:

1. A collapsible print drier for spatially positioning a plurality of prints to be dried comprising, a bottom member, a pair of side members, and a pair of end members, lug and slot means removably securing said bottom, end and side members together to facilitate the assembly and disassembly of the drier, a plurality of print-receiving grooves formed along opposed inner wall surfaces of said side members, means for venting said bottom, side and end members to facilitate the drying of prints positioned within said print-receiving grooves, a filler member frictionally positioned within said drier with a bottom portion resting upon said bottom member and a back portion positioned against an inner surface portion of one of said side members, said filler member having a plurality of vertically and horizontally-extending print-receiving grooves which cooperate with the print-receiving groove formed along the inner surface of the other of said side members for positionably retaining small size prints within the print drier.

2. A print drier for retaining and drying developed prints from a camera comprising, removably interlocking bottom, side and end members, a plurality of horizontally-spaced-apart and vertically-extending inwardly-projecting flange portions formed along an inner wall of each of said side members, said flanges and said inner wall forming cooperatively-opposed print-receiving grooves formed between said flanges portion and extending substantially along the full vertical extent of said side members, a print to be dried supported within cooperating opposed print receiving grooves, means venting inner wall portions of each said cooperatively-opposed print-receiving grooves, and said side members having vertically-extending recessed portions for receiving edge portions of said end members therewithin and horizontally-extending grooves for receiving side portions of said bottom member.

3. A collapsible and easily portable print drier for holding a plurality of prints to be dried in an adequately vented spaced-apart relationship comprising a ventilated bottom member, a pair of side members, and a pair of ventilated end members; said side members having recessed portions for receiving said bottom and end members therewithin, a plurality of slots formed through said side members adjacent said recessed portions, lug means formed integral with edge portions of said bottom and end members for projecting through said slots and forming a releasable locking engagement with said side members, the recessed portions and slots formed in said side walls for receiving the lugs of the bottom member being located to maintain said bottom member in an elevated position above bottom edges of said side members to provide for the passage of air to said ventilated bottom member, a plurality of inwardly-open and horizontally-spaced-apart grooves formed along the inner surface of each side member for positionably receiving prints, flange portions extending between said grooves for maintaining the prints in a spaced-apart relationship, and means venting each of said grooves for providing cross ventilation between said side members to facilitate the drying of the prints.

4. A collapsible and easily portable print drier for holding a plurality of prints to be dried in an adequately vented, spaced-apart relationship comprising, a ventilated bottom member, a pair of side members, and a pair of ventilated end members; said side members having recessed portions for receiving said bottom and end members therewithin, a plurality of slots formed through said side members adjacent said recessed portions, lug means formed integral with edge portions of said bottom and end

5

members for projecting through said slots and forming a releasable locking engagement with said side members, a plurality of inwardly-open and horizontally-spaced-apart grooves formed along the inner surface of each side member for positionally receiving prints, flange portions extending between said grooves for maintaining the prints in a spaced-apart relationship; at least one print to be dried positioned within said grooves; and means venting each of said grooves for providing cross ventilation between said side members to facilitate the drying of the print.

5. Portable apparatus for drying photographic prints comprising, a substantially rectangular box having four normally vertical side walls and a bottom wall, opposed internal surfaces of two of said side walls having vertically-extending print-edge-gripping flanges that are securely connected thereto in a mutually-opposed cooperative relationship for providing a plurality of print-receiving grooves to support photographic prints within said box, at least one photographic print positioned within cooperating print-receiving grooves, at least one of said side walls and said bottom wall having ventilation openings extending therethrough, said ventilation openings being positioned with respect to said print-receiving grooves so as to provide communication of drying air to opposed sides of the print supported by said grooves, and box support means securely connected to and extending outwardly of said box from at least one of said side walls to provide for drying air flow freely through said ventilation openings in said bottom wall.

6

6. Portable apparatus for drying photographic prints comprising:

- A. a box having four vertical side walls and a bottom wall, box support means integrally and cooperatively associated with at least one of said walls for supporting said box while maintaining said bottom wall in free communication with the atmosphere;
- B. internally-directed cooperating flange means securely connected to opposed internal side walls of said box and forming print-receiving grooves within said box;
- C. a photographic print positioned within said box and supported by said cooperating flange means; and
- D. ventilation openings positioned in at least one of said side walls and in said bottom wall for providing a circulation of drying air into and out of said box, and past the print positioned therein.

References Cited in the file of this patent

UNITED STATES PATENTS

1,061,297	Johnson	May 13, 1913
1,120,472	Freeman	Dec. 8, 1914
2,143,638	Weidman	Jan. 10, 1939
2,530,849	Wyatt et al.	Nov. 21, 1950
2,774,472	Badalich	Dec. 18, 1956
2,801,742	Farrell	Aug. 6, 1957
2,900,074	Windman	Aug. 18, 1959
2,985,333	Kirkman	May 23, 1961