



- (51) International Patent Classification:  
C25B 3/04 (2006.01)
- (21) International Application Number:  
PCT/US2013/029425
- (22) International Filing Date:  
6 March 2013 (06.03.2013)
- (25) Filing Language: English
- (26) Publication Language: English
- (30) Priority Data:  
61/607,240 6 March 2012 (06.03.2012) US  
61/609,088 9 March 2012 (09.03.2012) US
- (71) Applicant: **LIQUID LIGHT, INC.** [US/US]; 11 Deer Park Drive, Suite 121, Monmouth Junction, NJ 08852 (US).
- (72) Inventors: **COLE, Emily, Barton**; 5353 Memorial Drive, Suite 3004, Houston, TX 77007 (US). **SIVASANKAR, Narayanappa**; 916 Aspen Drive, Plainsboro, NJ 08536 (US). **PARAJULI, Rishi**; 3500 Barrett Drive, Apt. 8M, Kendell Park, NJ 08824 (US). **KEETS, Kate A.**; G14 Shirley Lane, Lawrenceville, NJ 08648 (US). **KEYSHAR, Kunttal**; 2410 Shakespeare St. Unit #86, Houston, TX 77030 (US).
- (74) Agent: **HONZ, Daniel, J.**; Suiter Swantz PC LLO, 14301 FNB Parkway, Suite 220, Omaha, NE 68154-5299 (US).

- (81) Designated States (unless otherwise indicated, for every kind of national protection available): AE, AG, AL, AM, AO, AT, AU, AZ, BA, BB, BG, BH, BN, BR, BW, BY, BZ, CA, CH, CL, CN, CO, CR, CU, CZ, DE, DK, DM, DO, DZ, EC, EE, EG, ES, FI, GB, GD, GE, GH, GM, GT, HN, HR, HU, ID, IL, IN, IS, JP, KE, KG, KM, KN, KP, KR, KZ, LA, LC, LK, LR, LS, LT, LU, LY, MA, MD, ME, MG, MK, MN, MW, MX, MY, MZ, NA, NG, NI, NO, NZ, OM, PA, PE, PG, PH, PL, PT, QA, RO, RS, RU, RW, SC, SD, SE, SG, SK, SL, SM, ST, SV, SY, TH, TJ, TM, TN, TR, TT, TZ, UA, UG, US, UZ, VC, VN, ZA, ZM, ZW.
- (84) Designated States (unless otherwise indicated, for every kind of regional protection available): ARIPO (BW, GH, GM, KE, LR, LS, MW, MZ, NA, RW, SD, SL, SZ, TZ, UG, ZM, ZW), Eurasian (AM, AZ, BY, KG, KZ, RU, TJ, TM), European (AL, AT, BE, BG, CH, CY, CZ, DE, DK, EE, ES, FI, FR, GB, GR, HR, HU, IE, IS, IT, LT, LU, LV, MC, MK, MT, NL, NO, PL, PT, RO, RS, SE, SI, SK, SM, TR), OAPI (BF, BJ, CF, CG, CI, CM, GA, GN, GQ, GW, ML, MR, NE, SN, TD, TG).

Published:  
— with international search report (Art. 21(3))

(54) Title: REDUCING CARBON DIOXIDE TO PRODUCTS

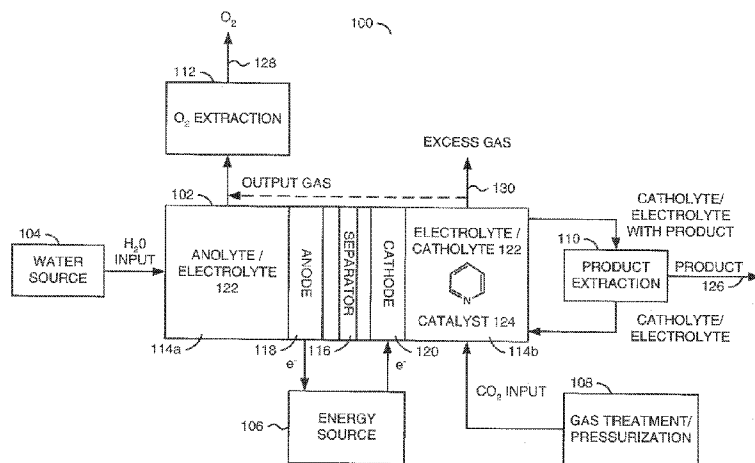

FIG. 1

(57) Abstract: A method reducing carbon dioxide to one or more products may include steps (A) to (C). Step (A) may bubble said carbon dioxide into a solution of an electrolyte and a catalyst in a divided electrochemical cell. The divided electrochemical cell may include an anode in a first cell compartment and a cathode in a second cell compartment. The cathode may reduce said carbon dioxide into said products. Step (B) may adjust one or more of (a) a cathode material, (b) a surface morphology of said cathode, (c) said electrolyte, (d) a manner in which said carbon dioxide is bubbled, (e), a pH level of said solution, and (f) an electrical potential of said divided electrochemical cell, to vary at least one of (i) which of said products is produced and (ii) a faradaic yield of said products. Step (C) may separate said products from said solution.

WO 2013/134418 A1

## **REDUCING CARBON DIOXIDE TO PRODUCTS**

### **Field**

[0001] The present invention relates to chemical reduction generally and, more particularly, to a method and/or apparatus for implementing reducing carbon dioxide to products.

### **Background**

[0002] The combustion of fossil fuels in activities such as the electricity generation, transportation, and manufacturing produces billions of tons of carbon dioxide annually. Research since the 1970s indicates increasing concentrations of carbon dioxide in the atmosphere may be responsible for altering the Earth's climate, changing the pH of the ocean and other potentially damaging effects. Countries around the world, including the United States, are seeking ways to mitigate emissions of carbon dioxide.

[0003] A mechanism for mitigating emissions is to convert carbon dioxide into economically valuable materials such as fuels and industrial chemicals. If the carbon dioxide is converted using energy from renewable sources, both mitigation of carbon dioxide emissions and conversion of renewable energy into a chemical form that can be stored for later use will be possible. Electrochemical and photochemical pathways are means for the carbon dioxide conversion.

### **Summary of the Preferred Embodiments**

[0004] The present disclosure concerns methods for reducing carbon dioxide to one or more products. The methods may include steps (A) to (C). Step (A) may bubble the carbon dioxide into a solution of an electrolyte and a catalyst in a divided electrochemical cell. The divided electrochemical cell may include an anode in a first cell compartment and a cathode in a second cell compartment. The cathode generally reduces the carbon dioxide into the products. Step (B) may adjust one or more of (a) a cathode material, (b) a surface morphology of said cathode, (c) said electrolyte, (d) a manner in which said carbon dioxide is bubbled, (e), a pH level of said solution, and (f) an electrical potential of said divided electrochemical cell, to vary at least one of (i) which of said products is produced and (ii) a faradaic yield of said products. Step (C) may separate the products from the solution.

[0005] The present disclosure concerns a system for electrochemical reduction of carbon dioxide. The system may include an electrochemical cell, which may include a first cell compartment, an anode positioned within said first cell compartment, a second cell compartment, a separator interposed between said first cell compartment and said second cell compartment. The second cell compartment may contain an electrolyte. The electrochemical cell may include a cathode within said second cell compartment. The cathode may be selected from the group consisting of n-GaAs, SS304, n-Ge, NiCo<sub>2</sub>O<sub>4</sub>, Rh, and mixtures thereof. The system may also include an energy source operably coupled with said anode and said cathode. The energy source may be configured to apply a voltage between said anode and said cathode to reduce carbon dioxide at said cathode to at least one of acetate, acetic acid, glycolate, and glycolic acid.

[0006] The present disclosure concerns a system for electrochemical reduction of carbon dioxide. The system may include an electrochemical cell, which may include a first cell compartment, an anode positioned within said first cell compartment, a second cell compartment, a separator interposed between said first cell compartment and said second cell compartment. The second cell compartment may contain an electrolyte. The electrochemical cell may include a cathode and a homogenous catalyst positioned within said second cell compartment. The cathode may comprise tin (Sn). The catalyst may include at least one of pyridine, 2-picoline or 2,6-lutidine. The system may also include an energy source operably coupled with said anode and said cathode. The energy source may be configured to apply a voltage between said anode and said cathode to reduce carbon dioxide at said cathode to at least one of formate or formic acid.

[0007] The present disclosure concerns a method for reducing carbon dioxide to one or more organic products may include steps (A) to (C). Step (A) may introduce an anolyte to a first compartment of an electrochemical cell, said first compartment including an anode. Step (B) may introduce a catholyte and carbon dioxide to a second compartment of said electrochemical cell. The second compartment may include a tin cathode and a catalyst. The catalyst may include at least one of pyridine, 2-picoline or 2,6-lutidine. Step (C) may apply an electrical potential between said anode and said cathode sufficient for said cathode to reduce said carbon dioxide to at least one of formate or formic acid.

### **Brief Description of the Drawings**

[0008] These and other objects, features and advantages of the present invention will be apparent from the following detailed description and the appended claims and drawings in which:

FIG. 1 is a block diagram of a system in accordance with a preferred embodiment of the present invention;

FIGS. 2A-2C are tables illustrating relative product yields for different cathode material, catalyst, electrolyte and pH level combinations;

FIG. 3 is a formula of an aromatic heterocyclic amine catalyst;

FIGS. 4-6 are formulae of substituted or unsubstituted aromatic 5-member heterocyclic amines or 6-member heterocyclic amines;

FIG. 7 is a flow diagram of an example method used in electrochemical examples; and

FIG. 8 is a flow diagram of an example method used in photochemical examples.

### **Detailed Description of the Preferred Embodiments**

[0009] In accordance with some embodiments of the present invention, an electro-catalytic system is provided that generally allows carbon dioxide to be converted at modest overpotentials to highly reduced species in an aqueous solution. Some embodiments generally relate to simple, efficient and economical conversion of carbon dioxide to reduced organic products, such as methanol, formic acid and formaldehyde. Inorganic products such as polymers may also be formed. Carbon-carbon bonds and/or carbon-hydrogen bonds may be formed in the aqueous solution under mild conditions utilizing a minimum of energy. In some embodiments, the energy used by the system may be generated from an alternative energy source or directly using visible light, depending on how the system is implemented.

[00010] The reduction of carbon dioxide may be suitably catalyzed by aromatic heterocyclic amines (e.g., pyridine, imidazole and substituted derivatives). Simple organic compounds have been found to be effective and stable homogenous electrocatalysts and photoelectrocatalysts for the aqueous multiple electron, multiple proton reduction of carbon dioxide to organic products, such as formic acid, formaldehyde and methanol. For

production of methanol, the reduction of carbon dioxide may proceed along a electron (e-) transfer pathway. High faradaic yields for the reduced products have generally been found in both electrochemical and photoelectrochemical systems at low reaction overpotentials.

**[00011]** Metal-derived multi-electron transfer was previously thought to achieve highly reduced products such as methanol. Currently, simple aromatic heterocyclic amine molecules may be capable of producing many different chemical species on route to methanol through multiple electron transfers, instead of metal-based multi-electron transfers.

**[00012]** Some embodiments of the present invention thus relate to environmentally beneficial methods for reducing carbon dioxide. The methods generally include electrochemically and/or photoelectrochemically reducing the carbon dioxide in an aqueous, electrolyte-supported divided electrochemical cell that includes an anode (e.g., an inert conductive counter electrode) in a cell compartment and a conductive or p-type semiconductor working cathode electrode in another cell compartment. A catalyst may be included to produce a reduced product. Carbon dioxide may be continuously bubbled through the cathode electrolyte solution to saturate the solution.

**[00013]** For electrochemical reductions, the electrode may be a suitable conductive electrode, such as Al, Au, Ag, Bi, C, Cd, Co, Cr, Cu, Cu alloys (e.g., brass and bronze), Ga, Hg, In, Mo, Nb, Ni, NiCo<sub>2</sub>O<sub>4</sub>, Ni alloys (e.g., Ni 625, NiHX), Ni-Fe alloys, Pb, Pd alloys (e.g., PdAg), Pt, Pt alloys (e.g., PtRh), Rh, Sn, Sn alloys (e.g., SnAg, SnPb, SnSb), Ti, V, W, Zn, stainless steel (SS) (e.g., SS 2205, SS 304, SS 316, SS 321), austenitic steel, ferritic steel, duplex steel, martensitic steel, Nichrome (e.g., NiCr 60:16 (with Fe)), elgiloy (e.g., Co-Ni-Cr), degenerately doped p-Si, degenerately doped p-Si:As, degenerately doped p-Si:B, degenerately doped n-Si, degenerately doped n-Si:As, and degenerately doped n-Si:B. Other conductive electrodes may be implemented to meet the criteria of a particular application. For photoelectrochemical reductions, the electrode may be a p-type semiconductor, such as p-GaAs, p-GaP, p-InN, p-InP, p-CdTe, p-GaInP<sub>2</sub> and p-Si, or an n-type semiconductor, such as n-GaAs, n-GaP, n-InN, n-InP, n-CdTe, n-GaInP<sub>2</sub> and n-Si. Other semiconductor electrodes may be implemented to meet the criteria of a particular application including, but not limited to, CoS, MoS<sub>2</sub>, TiB, WS<sub>2</sub>, SnS, Ag<sub>2</sub>S, CoP<sub>2</sub>, Fe<sub>3</sub>P, Mn<sub>3</sub>P<sub>2</sub>, MoP, Ni<sub>2</sub>Si, MoSi<sub>2</sub>, WSi<sub>2</sub>, CoSi<sub>2</sub>, TiO<sub>7</sub>, SnO<sub>2</sub>, GaAs, GaSb, Ge, and CdSe.

[00014] The catalyst for conversion of carbon dioxide electrochemically or photoelectrochemically may be a substituted or unsubstituted aromatic heterocyclic amine. Suitable amines are generally heterocycles which may include, but are not limited to, heterocyclic compounds that are 5-member or 6-member rings with at least one ring nitrogen. For example, pyridines, imidazoles and related species with at least one five-member ring, bipyridines (e.g., two connected pyridines) and substituted derivatives were generally found suitable as catalysts for the electrochemical reduction and/or the photoelectrochemical reduction. Amines that have sulfur or oxygen in the rings may also be suitable for the reductions. Amines with sulfur or oxygen may include thiazoles or oxazoles. Other aromatic amines (e.g., quinolines, adenine, azoles, indoles, benzimidazole and 1,10-phenanthroline) may also be effective electrocatalysts.

[00015] Carbon dioxide may be photochemically or electrochemically reduced to formic acid with formaldehyde and methanol being formed in smaller amounts. Catalytic hydrogenation of carbon dioxide using heterogeneous catalysts generally provides methanol together with water as well as formic acid and formaldehyde. The reduction of carbon dioxide to methanol with complex metal hydrides, such as lithium aluminum hydrides, may be costly and therefore problematic for bulk production of methanol. Current reduction processes are generally highly energy-consuming and thus are not efficient ways for a high yield, economical conversion of carbon dioxide to various products.

[00016] On the other hand, the use of processes for converting carbon dioxide to reduced organic and/or inorganic products in accordance with some embodiments of the invention generally has the potential to lead to a significant reduction of carbon dioxide, a major greenhouse gas, in the atmosphere and thus to the mitigation of global warming. Moreover, some embodiments may advantageously produce methanol and related products without adding extra reactants, such as a hydrogen source. The resultant product mixture may use little in the way of further treatment. For example, a resultant 1 molar (M) methanol solution may be used directly in a fuel cell. For other uses, simple removal of the electrolyte salt and water may be readily accomplished.

[00017] Before any embodiments of the invention are explained in detail, it is to be understood that the embodiments may not be limited in application per the details of the structure or the function as set forth in the following descriptions or illustrated in the figures

of the drawing. Different embodiments may be capable of being practiced or carried out in various ways. Also, it is to be understood that the phraseology and terminology used herein is for the purpose of description and should not be regarded as limiting. The use of terms such as "including," "comprising," or "having" and variations thereof herein are generally meant to encompass the item listed thereafter and equivalents thereof as well as additional items.

Further, unless otherwise noted, technical terms may be used according to conventional usage.

**[00018]** In the following description of methods, process steps may be carried out over a range of temperatures (e.g., approximately 10°C (Celsius) to 50°C) and a range of pressures (e.g., approximately 1 to 10 atmospheres) unless otherwise specified. Numerical ranges recited herein generally include all values from the lower value to the upper value (e.g., all possible combinations of numerical values between the lowest value and the highest value enumerated are considered expressly stated). For example, if a concentration range or beneficial effect range is stated as 1% to 50%, it is intended that values such as 2% to 40%, 10% to 30%, or 1% to 3%, etc., are expressly enumerated. The above may be simple examples of what is specifically intended.

**[00019]** A use of electrochemical or photoelectrochemical reduction of carbon dioxide, tailored with certain electrocatalysts, may produce methanol and related products in a high yield of about 60% to about 100%, based on the amount of carbon dioxide, suitably about 75% to 90%, and more suitably about 85% to 95%. At an electric potential of about -0.50 to -2 volts (V) with respect to a saturated calomel electrode (SCE), methanol may be produced with good faradaic efficiency at the cathode.

**[00020]** An example of an overall reaction for the reduction of carbon dioxide may be represented as follows:

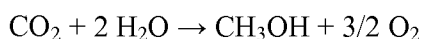

For a 6 e- reduction, the reactions at the cathode and anode may be represented as follows:

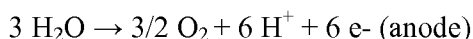

**[00021]** The reduction of the carbon dioxide may be suitably achieved efficiently in a divided electrochemical or photoelectrochemical cell in which (i) a compartment contains an

anode that is an inert counter electrode and (ii) another compartment contains a working cathode electrode and a catalyst. The compartments may be separated by a porous glass frit or other ion conducting bridge. Both compartments generally contain an aqueous solution of an electrolyte. Carbon dioxide gas may be continuously bubbled through the cathodic electrolyte solution to saturate the solution.

**[00022]** In the working electrode compartment, carbon dioxide may be continuously bubbled through the solution. In some embodiments, if the working electrode is a conductor, an external bias may be impressed across the cell such that the potential of the working electrode is held constant. In other embodiments, if the working electrode is a p-type semiconductor, the electrode may be suitably illuminated with light. An energy of the light may be matching or greater than a bandgap of the semiconductor during the electrolysis. Furthermore, either no external source of electrical energy may be used or a modest bias (e.g., about 500 millivolts) may be applied. The working electrode potential is generally held constant relative to the SCE. The electrical energy for the electrochemical reduction of carbon dioxide may come from a normal energy source, including nuclear and alternatives (e.g., hydroelectric, wind, solar power, geothermal, etc.), from a solar cell or other nonfossil fuel source of electricity, provided that the electrical source supply at least 1.6 volts across the cell. Other voltage values may be adjusted depending on the internal resistance of the cell employed.

**[00023]** Advantageously, the carbon dioxide may be obtained from any sources (e.g., an exhaust stream from fossil-fuel burning power or industrial plants, from geothermal or natural gas wells or the atmosphere itself). Most suitably, the carbon dioxide may be obtained from concentrated point sources of generation prior to being released into the atmosphere. For example, high concentration carbon dioxide sources may frequently accompany natural gas in amounts of 5% to 50%, exist in flue gases of fossil fuel (e.g., coal, natural gas, oil, etc.) burning power plants and nearly pure carbon dioxide may be exhausted from cement factories and from fermenters used for industrial fermentation of ethanol. Certain geothermal steams may also contain significant amounts of carbon dioxide. The carbon dioxide emissions from varied industries, including geothermal wells, may be captured on-site. Separation of the carbon dioxide from such exhausts is known. Thus, the capture and use of existing atmospheric carbon dioxide in accordance with some embodiments of the present invention generally allow the carbon dioxide to be a renewable and unlimited source of

carbon.

**[00024]** For electrochemical conversions, the carbon dioxide may be readily reduced in an aqueous medium with a conductive electrode. Faradaic efficiencies have been found high, some reaching about 100%. For photoelectrochemical conversions, the carbon dioxide may be readily reduced with a p-type semiconductor electrode, such as p-GaP, p-GaAs, p-InP, p-InN, p-WSe<sub>2</sub>, p-CdTe, p-GaInP<sub>2</sub> and p-Si.

**[00025]** The electrochemical/photoelectrochemical reduction of the carbon dioxide generally utilizes one or more catalysts in the aqueous solution. Aromatic heterocyclic amines may include, but are not limited to, unsubstituted and substituted pyridines and imidazoles. Substituted pyridines and imidazoles may include, but are not limited to mono and disubstituted pyridines and imidazoles. For example, suitable catalysts may include straight chain or branched chain lower alkyl (e.g., C1-C10) mono and disubstituted compounds such as 2-methylpyridine, 4-tertbutyl pyridine, 2,6-dimethylpyridine (2,6-lutidine); bipyridines, such as 4,4'-bipyridine; amino-substituted pyridines, such as 4-dimethylamino pyridine; and hydroxyl-substituted pyridines (e.g., 4-hydroxy-pyridine) and substituted or unsubstituted quinoline or isoquinolines. The catalysts may also suitably include substituted or unsubstituted dinitrogen heterocyclic amines, such as pyrazine, pyridazine and pyrimidine. Other catalysts generally include azoles, imidazoles, indoles, oxazoles, thiazoles, substituted species and complex multi-ring amines such as adenine, pterin, pteridine, benzimidazole, phenanthroline and the like.

**[00026]** Referring to FIG. 1, a block diagram of a system 100 is shown in accordance with a preferred embodiment of the present invention. The system (or apparatus) 100 generally comprises a cell (or container) 102, a liquid source 104, a power source 106, a gas source 108, an extractor 110 and an extractor 112. A product may be presented from the extractor 110. An output gas may be presented from the extractor 112. Another output gas may be presented from the cell 102.

**[00027]** The cell 102 may be implemented as a divided cell. The divided cell may be a divided electrochemical cell and/or a divided photochemical cell. The cell 102 is generally operational to reduce carbon dioxide (CO<sub>2</sub>) and protons into one or more organic products and/or inorganic products. The reduction generally takes place by bubbling carbon dioxide

into an aqueous solution of an electrolyte in the cell 102. A cathode in the cell 102 may reduce the carbon dioxide into one or more compounds.

**[00028]** The cell 102 generally comprises two or more compartments (or chambers) 114a-114b, a separator (or membrane) 116, an anode 118 and a cathode 120. The anode 118 may be disposed in a given compartment (e.g., 114a). The cathode 120 may be disposed in another compartment (e.g., 114b) on a side of the separator 116 opposite the anode 118. An aqueous solution 122 may fill both compartments 114a-114b. A catalyst 124 may be added to the compartment 114b containing the cathode 120.

**[00029]** The liquid source 104 may implement a water source. The liquid source 104 may be operational to provide pure water to the cell 102.

**[00030]** The power source 106 may implement a variable voltage source. The source 106 may be operational to generate an electrical potential between the anode 118 and the cathode 120. The electrical potential may be a DC voltage.

**[00031]** The gas source 108 may implement a carbon dioxide source. The source 108 is generally operational to provide carbon dioxide to the cell 102. In some embodiments, the carbon dioxide is bubbled directly into the compartment 114b containing the cathode 120 and the electrolyte 122. In a preferred embodiment, a carbon dioxide-saturated electrolyte is introduced to the cell 102. The electrolyte 122 may include one or more of Na<sub>2</sub>SO<sub>4</sub>, KHCO<sub>3</sub>, KCl, NaNO<sub>3</sub>, NaCl, NaF, NaClO<sub>4</sub>, KClO<sub>4</sub>, K<sub>2</sub>SiO<sub>3</sub>, CaCl<sub>2</sub>, a guanidinium cation, a H<sup>+</sup> ion, an alkali metal cation, an ammonium cation, an alkylammonium cation, a halide ion, an alkyl amine, a borate, a carbonate, a guanidinium derivative, a nitrite, a nitrate, a phosphate, a polyphosphate, a perchlorate, a silicate, a sulfate, and a tetraalkyl ammonium salt.

**[00032]** The extractor 110 may implement an organic product and/or inorganic product extractor. The extractor 110 is generally operational to extract (separate) products (e.g., formic acid, acetone, glyoxal, isopropanol, formaldehyde, methanol, polymers and the like) from the electrolyte 122. The extracted products may be presented through a port 126 of the system 100 for subsequent storage and/or consumption by other devices and/or processes.

[00033] The extractor 112 may implement an oxygen extractor. The extractor 112 is generally operational to extract oxygen (e.g., O<sub>2</sub>) byproducts created by the reduction of the carbon dioxide and/or the oxidation of water. The extracted oxygen may be presented through a port 128 of the system 100 for subsequent storage and/or consumption by other devices and/or processes. Chlorine and/or oxidatively evolved chemicals may also be byproducts in some configurations. The organic pollutants may be rendered harmless by oxidization. Any other excess gases (e.g., hydrogen) created during the reduction of the carbon dioxide may be vented from the cell 102 via a port 130.

[00034] In the process described, water may be oxidized (or split) to protons and oxygen at the anode 118 while the carbon dioxide is reduced to organic products at the cathode 120. The electrolyte 122 in the cell 102 may use water as a solvent with any salts that are water soluble and with a pyridine or pyridine-derived catalyst 124. The catalysts 124 may include, but are not limited to, nitrogen, sulfur and oxygen containing heterocycles. Examples of the heterocyclic compounds may be pyridine, imidazole, pyrrole, thiazole, furan, thiophene and the substituted heterocycles such as amino-thiazole and benzimidazole. Cathode materials generally include any conductor. Any anode material may be used. The overall process is generally driven by the power source 106. Combinations of cathodes 120, electrolytes 122, catalysts 124, introduction of carbon dioxide to the cell 102, introduction of divalent cations (e.g., Ca<sup>2+</sup>, Mg<sup>2+</sup>, Zn<sup>2+</sup>) to the electrolytes 122, pH levels and electric potential from the power source 106 may be used to control the reaction products of the cell 102. For instance, the pH of electrolyte solution may be maintained between about pH 1 and pH 8 with a suitable range depending on what product or products are desired. Organic products and inorganic products resulting from the reaction may include, but are not limited to, acetaldehyde, acetate, acetic acid, acetone, 1-butanol, 2-butanol, 2-butanone, carbon, carbon monoxide, carbonates, ethane, ethanol, ethylene, formaldehyde, formate, formic acid, glycolate, glycolic acid, glyoxal, glyoxylate, glyoxylic acid, graphite, isopropanol, lactate, lactic acid, methane, methanol, oxalate, oxalic acid, a polymer containing carbon dioxide, 1-propanal, 1-propanol, and propionic acid.

[00035] In particular implementations, the cell 102 includes a tin (Sn) cathode for the production of formate. A catalyst is preferably used, with the catalyst preferably including one or more of pyridine, 2-picoline and 2,6-lutadine. The preferred catalyst concentration is between about 1ppm and 100mM, and more preferably between about 0.01mM and 30mM.

The electrolyte in the cell 102 may include potassium chloride with a concentration of 0.5 M, however other electrolytes may be utilized, including but not limited to, another chloride electrolyte (e.g., LiCl, CsCl, NH<sub>4</sub>Cl), a perchlorate electrolyte, a phosphate electrolyte, a bicarbonate electrolyte, and a sulfate electrolyte. During operation of the cell, a surface hydroxide may develop on the surface of the tin cathode. Such surface hydroxide development may lead to a decrease in current density of the cell, but product yields may remain stable for an extended period of time. For example, in one preferred embodiment, stable yields were obtained in a duration that exceeded 145 hours. To address the surface hydroxide development, an acidic solution may be introduced to the cathode compartment, where additional protons may be made available at the cathode surface to neutralize the hydroxide to water. A pH buffer may be utilized to maintain a preferred pH range in the cathode compartment of between about 1 and 7, with a more preferable pH range of between 3 and 6, and even more preferable pH range of between 3 and 4.5. In one embodiment, the pH buffer is a phosphate buffer, which may be a 0.2M phosphate buffer. A cation mixture may also be introduced to the catholyte compartment which also may address the formation of the surface hydroxide development. Preferred cations include mixture of cations such as K<sup>+</sup>/Cs<sup>+</sup>, Li<sup>+</sup>/K<sup>+</sup> and Li<sup>+</sup>/Cs<sup>+</sup> combinations, which may be introduced in a molar ratio between about 1:1000 and 1000:1. Na<sup>+</sup> works equally good in place of K<sup>+</sup>.

**[00036]** In some nonaqueous embodiments, the solvent may include methanol, acetonitrile, and/or other nonaqueous solvents. The electrolytes 122 generally include tetraalkyl ammonium salts and a heterocyclic catalyst. A primary product may be oxalate in a completely nonaqueous system. In a system containing a nonaqueous catholyte and an aqueous anolyte, the products generally include all of the products seen in aqueous systems with higher yields.

**[00037]** Experiments were conducted in one, two and three-compartment electrochemical cells 102 with an SCE as the reference electrode. The experiments were generally conducted at ambient temperature and pressure. Current densities were observed to increase with increased temperature, but the experiments were generally operated at ambient temperature for best efficiency. Carbon dioxide was bubbled into the cells during the experiments. A potentiostat or DC power supply 106 provided the electrical energy to drive the process. Cell potentials ranged from 2 volts to 4 volts, depending on the cathode material. Half cell potentials at the cathode ranged from -0.7 volts to -2 volts relative to the SCE,

depending on the cathode material used. Products from the experiments were analyzed using gas chromatography and a spectrometer.

**[00038]** The process is generally controlled to get a desired product by using combinations of specific cathode materials, catalysts, electrolytes, surface morphology of the electrodes, introduction of reactants relative to the cathode, introduction of divalent cations to the electrolyte, adjusting pH levels and/or adjusting electrical potentials. Faradaic yields for the products generally range from less than 1% to more than 90% with the remainder being hydrogen, though methane, carbon monoxide and/or ethylene may also be produced as gaseous byproducts.

**[00039]** Referring to FIGS. 2A-2C, tables illustrating relative product yields for different cathode material, catalyst, electrolyte, pH level and cathode potential combinations are shown. The combinations listed in the tables generally are not the only combinations providing a given product. The combinations illustrated may demonstrate high yields of the products at the lowest potential. The cathodes tested generally include all conductive elements on the periodic table, steels, nickel alloys, copper alloys such as brass and bronze and elgiloy. Most of the conductors may be used with heterocyclic catalysts 124 to reduce the carbon dioxide. The products created may vary based on which cathode material is used. For instance, a W cathode 120 with pyridine catalyst 124 may give acetone as a product whereas a Sn cathode 120 with pyridine may primarily give formic acid and methanol as products. A product yield may also be changed by the manner in which the carbon dioxide was bubbled into the cell 102. For instance, with a stainless steel 2205 cathode 120 in a KCl electrolyte 122, if the carbon dioxide bubbles directly contact the cathode 120, the product mix may switch to methanol and isopropanol, rather than formic acid and acetone when the carbon dioxide bubbles avoid contact with the cathode 120 (i.e., the carbon dioxide bubbles circumvent the cathode 120 in the cell 102).

**[00040]** Cell design and cathode treatment (e.g., surface morphology or surface texture) may affect both product yields and current density at the cathode. For instance, a divided cell 102 with a stainless steel 2205 cathode 120 in a KCl electrolyte 122 generally has higher yields with a heavily scratched (rough) cathode 120 than an unscratched (smooth) cathode 120. In some embodiments, the roughness or smoothness of a cathode surface may be determined by a comparison between a surface area measurement and the geometric

surface area of the cathode, where the greater the difference between the surface area measurement and the geometric surface area, the rougher the cathode. Matte tin generally performs different than bright tin. Maintaining carbon dioxide bubbling only on the cathode side of the divided cell 102 (e.g., in compartment 114b) may also increase yields.

**[00041]** Raising or lowering the cathode potential may also alter the reduced products. For instance, ethanol is generally evolved at lower potentials between -0.8 volts and -1 volt using the duplex steel/pyridine/KCl, while methanol is favored beyond -1 volt.

**[00042]** Faradaic yields for the products may be improved by controlling the electrical potential of the reaction. By maintaining a constant potential at the cathode 120, hydrogen evolution is generally reduced and faradaic yields of the products increased. Addition of hydrogen inhibitors, such as acetonitrile, certain heterocycles, alcohols, and other chemicals may also increase yields of the products.

**[00043]** With some embodiments, stability may be improved with cathode materials known to poison rapidly when reducing carbon dioxide. Copper and copper-alloy electrodes commonly poison in less than an hour of electrochemically reducing carbon dioxide. However, when used with a heterocyclic amine catalyst, copper-based alloys were operated for many hours without any observed degradation in effectiveness. The effects were particularly enhanced by using sulfur containing heterocycles. For instance, a system with a copper cathode and 2-amino thiazole catalyst showed very high stability for the reduction of carbon dioxide to carbon monoxide and formic acid.

**[00044]** Heterocycles other than pyridine may catalytically reduce carbon dioxide in the electrochemical process using many aforementioned cathode materials, including tin, steels, nickel alloys and copper alloys. Nitrogen-containing heterocyclic amines shown to be effective include azoles, indoles, 4,4'-bipyridines, picolines (methyl pyridines), lutidines (dimethyl pyridines), hydroxy pyridines, imidazole, benzimidazole, methyl imidazole, pyrazine, pyrimidine, pyridazine, pyridazineimidazole, nicotinic acid, quinoline, adenine and 1,10-phenanthroline. Sulfur containing heterocycles include thiazole, aminothiazoles, thiophene. Oxygen containing heterocycles include furan and oxazole. As with pyridine, the combination of catalyst, cathode material and electrolyte may be used to control product mix.

[00045] Some process embodiments of the present invention for making/converting hydrocarbons generally consume a small amount of water (e.g., approximately 1 to 3 moles of water) per mole of carbon. Therefore, the processes may be a few thousand times more water efficient than existing production techniques.

[00046] Referring to FIG. 3, a formula of an aromatic heterocyclic amine catalyst is shown. The ring structure may be an aromatic 5-member heterocyclic ring or 6-member heterocyclic ring with at least one ring nitrogen and is optionally substituted at one or more ring positions other than nitrogen with R. L may be C or N. R1 may be H. R2 may be H if L is N or R2 is R if L is C. R is an optional substituent on any ring carbon and may be independently selected from H, a straight chain or branched chain lower alkyl, hydroxyl, amino, pyridyl, or two R's taken together with the ring carbons bonded thereto are a fused six-member aryl ring and n = 0 to 4.

[00047] Referring to FIGS. 4-6, formulae of substituted or unsubstituted aromatic 5-member heterocyclic amines or 6-member heterocyclic amines are shown. Referring to FIG. 4, R3 may be H. R4, R5, R7 and R8 are generally independently H, straight chain or branched chain lower alkyl, hydroxyl, amino, or taken together are a fused six-member aryl ring. R6 may be H, straight chain or branched chain lower alkyl, hydroxyl, amino or pyridyl.

[00048] Referring to FIG. 5, one of L1, L2 and L3 may be N, while the other L's may be C. R9 may be H. If L1 is N, R10 may be H. If L2 is N, R11 may be H. If L3 is N, R12 may be H. If L1, L2 or L3 is C, then R10, R11, R12, R13 and R14 may be independently selected from straight chain or branched chain lower alkyl, hydroxyl, amino, or pyridyl.

[00049] Referring to FIG. 6, R15 and R16 may be H. R17, R18 and R19 are generally independently selected from straight chain or branched chain lower alkyl, hydroxyl, amino, or pyridyl.

[00050] Suitably, the concentration of aromatic heterocyclic amine catalysts is about 1 millimolar (mM) to 1 M. The electrolyte may be suitably a salt, such as KCl, KHCO<sub>3</sub>, NaNO<sub>3</sub>, Na<sub>2</sub>SO<sub>4</sub>, NaClO<sub>4</sub>, NaF, NaClO<sub>4</sub>, KClO<sub>4</sub>, K<sub>2</sub>SiO<sub>3</sub>, or CaCl<sub>2</sub> at a concentration of about 0.5 M. Other electrolytes may include, but are not limited to, all group 1 cations (e.g., H, Li, Na, K, Rb and Cs) except Francium (Fr), Ca, ammonium cations,

alkylammonium cations and alkyl amines. Additional electrolytes may include, but are not limited to, all group 17 anions (e.g., F, Cl, Br, I and At), borates, carbonates, nitrates, nitrites, perchlorates, phosphates, polyphosphates, silicates and sulfates. Na generally performs as well as K with regard to best practices, so NaCl may be exchanged with KCl. NaF may perform about as well as NaCl, so NaF may be exchanged for NaCl or KCl in many cases. Larger anions tend to change the chemistry and favor different products. For instance, sulfate may favor polymer or methanol production while Cl may favor products such as acetone. The pH of the solution is generally maintained at about pH 3 to 8, suitably about 4.7 to 5.6.

**[00051]** At conductive electrodes, formic acid and formaldehyde were found to be intermediate products along the pathway to the 6 e<sup>-</sup> reduced product of methanol, with an aromatic amine radical (e.g., the pyridinium radical, playing a role in the reduction of both intermediate products). The intermediate products have generally been found to also be the final products of the reduction of carbon dioxide at conductive electrodes or p-type semiconductor electrodes, depending on the particular catalyst used. Other C-C couple products may also be possible. For example, reduction of carbon dioxide may suitably yield formaldehyde, formic acid, glyoxal, methanol, isopropanol, or ethanol, depending on the particular aromatic heterocyclic amine used as the catalyst. The products of the reduction of carbon dioxide are generally substitution-sensitive. As such, the products may be selectively produced. For example, use of 4,4'-bipyridine as the catalyst may produce methanol and/or 2-propanol. Lutidines and amino-substituted pyridines may produce 2-propanol. Hydroxypyridine may produce formic acid.

**[00052]** The effective electrochemical/photoelectrochemical reduction of carbon dioxide disclosed herein may provide new methods of producing methanol and other related products in an improved, efficient, and environmentally beneficial way, while mitigating carbon dioxide-caused climate change (e.g., global warming). Moreover, the methanol product of reduction of carbon dioxide may be advantageously used as (1) a convenient energy storage medium, which allows convenient and safe storage and handling, (2) a readily transported and dispensed fuel, including for methanol fuel cells and (3) a feedstock for synthetic hydrocarbons and corresponding products currently obtained from oil and gas resources, including polymers, biopolymers and even proteins, that may be used for animal feed or human consumption. Importantly, the use of methanol as an energy storage and transportation material generally eliminates many difficulties of using hydrogen for such

purposes. The safety and versatility of methanol generally makes the disclosed reduction of carbon dioxide further desirable.

**[00053]** Some embodiments of the present invention may be further explained by the following examples, which should not be construed by way of limiting the scope of the invention.

Example 1: General Electrochemical Methods.

Chemicals and materials. All chemicals used were > 98% purity and used as received from the vendor (e.g., Aldrich), without further purification. Either deionized or high purity water (Nanopure, Barnstead) was used to prepare the aqueous electrolyte solutions.

Electrochemical system. The electrochemical system was composed of a standard two-compartment electrolysis cell 102 to separate the anode 118 and cathode 120 reactions. The compartments were separated by a porous glass frit or other ion conducting bridge 116. The electrolytes 122 were used at concentrations of 0.1 M to 1 M, with 0.5 M being a typical concentration. A concentration of between about 1 mM to 1 M of the catalysts 124 were used. The particular electrolyte 122 and particular catalyst 124 of each given test were generally selected based upon what product or products were being created.

**[00054]** Referring to FIG. 7, a flow diagram of an example method 140 used in the electrochemical examples is shown. The method (or process) 140 generally comprises a step (or block) 142, a step (or block) 144, a step (or block) 146, a step (or block) 148 and a step (or block) 150. The method 140 may be implemented using the system 100.

**[00055]** In the step 142, the electrodes 118 and 120 may be activated where appropriate. Bubbling of the carbon dioxide into the cell 102 may be performed in the step 144. Electrolysis of the carbon dioxide into organic and/or inorganic products may occur during step 146. In the step 148, the products may be separated from the electrolyte. Analysis of the reduction products may be performed in the step 150.

**[00056]** The working electrode was of a known area. All potentials were measured with respect to a saturated calomel reference electrode (Accumet). Before and during all electrolysis, carbon dioxide (Airgas) was continuously bubbled through the electrolyte to saturate the solution. The resulting pH of the solution was maintained at about pH 3 to pH 8 with a suitable range depending on what product or products were being made. For example,

under constant carbon dioxide bubbling, the pH levels of 10 mM solutions of 4-hydroxy pyridine, pyridine and 4-tertbutyl pyridine were 4.7, 5.28 and 5.55, respectively. For Nuclear Magnetic Resonance (NMR) experiments, isotopically enriched  $\text{NaH}^{13}\text{CO}_3$  (99%) was obtained from Cambridge Isotope Laboratories, Inc.

Example 2: General Photoelectrochemical Methods.

Chemicals and materials. All chemicals used were analytical grade or higher. Either deionized or high purity water (Nanopure, Barnstead) was used to prepare the aqueous electrolyte solutions.

Photoelectrochemical system. The photoelectrochemical system was composed of a Pyrex three-necked flask containing 0.5 M KCl as supporting electrolyte and a 1 mM to 1 M catalyst (e.g., 10 mM pyridine or pyridine derivative). The photocathode was a single crystal p-type semiconductor etched for approximately 1 to 2 minutes in a bath of concentrated  $\text{HNO}_3:\text{HCl}$ , 2:1 v/v prior to use. An ohmic contact was made to the back of the freshly etched crystal using an indium/zinc (2 wt. % Zn) solder. The contact was connected to an external lead with conducting silver epoxy (Epoxy Technology H31) covered in glass tubing and insulated using an epoxy cement (Loctite 0151 Hysol) to expose only the front face of the semiconductor to solution. All potentials were referenced against a saturated calomel electrode (Accumet). The three electrode assembly was completed with a carbon rod counter electrode to minimize the reoxidation of reduced carbon dioxide products. During all electrolysis, carbon dioxide gas (Airgas) was continuously bubbled through the electrolyte to saturate the solution. The resulting pH of the solution was maintained at about pH 3 to 8 (e.g., pH 5.2).

[00057] Referring to FIG. 8, a flow diagram of an example method 160 used in the photochemical examples is shown. The method (or process) 160 generally comprises a step (or block) 162, a step (or block) 164, a step (or block) 166, a step (or block) 168 and a step (or block) 170. The method 160 may be implemented using the system 100.

[00058] In the step 162, the photoelectrode may be activated. Bubbling of the carbon dioxide into the cell 102 may be performed in the step 164. Electrolysis of the carbon dioxide into the products may occur during step 166. In the step 168, the products may be separated from the electrolyte. Analysis of the reduction products may be performed in the step 170.

[00059] Light sources. Four different light sources were used for the illumination of

the p-type semiconductor electrode. For initial electrolysis experiments, a Hg-Xe arc lamp (USHIO UXM 200H) was used in a lamp housing (PTI Model A-1010) and powered by a PTI LTS-200 power supply. Similarly, a Xe arc lamp (USHIO UXL 151H) was used in the same housing in conjunction with a PTI monochromator to illuminate the electrode at various specific wavelengths.

**[00060]** A fiber optic spectrometer (Ocean Optics S2000) or a silicon photodetector (Newport 818-SL silicon detector) was used to measure the relative resulting power emitted through the monochromator. The flatband potential was obtained by measurements of the open circuit photovoltage during various irradiation intensities using the 200 watt (*W*) Hg-Xe lamp ( $3 \text{ W/cm}^2$  -  $23 \text{ W/cm}^2$ ). The photovoltage was observed to saturate at intensities above approximately  $6 \text{ W/cm}^2$ .

**[00061]** For quantum yield determinations, electrolysis was performed under illumination by two different light-emitting diodes (LEDs). A blue LED (Luxeon V Dental Blue, Future Electronics) with a luminous output of 500 milliwatt (mW) +/- 50 mW at 465 nanometers (nm) and a 20 nm full width at half maximum (FWHM) was driven at to a maximum rated current of 700 mA using a Xitanium Driver (Advance Transformer Company). A Fraen collimating lens (Future Electronics) was used to direct the output light. The resultant power density that reached the window of the photoelectrochemical cell was determined to be  $42 \text{ mW/cm}^2$ , measured using a Scientech 364 thermopile power meter and silicon photodetector. The measured power density was assumed to be greater than the actual power density observed at the semiconductor face due to luminous intensity loss through the solution layer between the wall of the photoelectrochemical cell and the electrode.

#### Example 3: Analysis of Products of Electrolysis.

Electrochemical experiments were generally performed using a CH Instruments potentiostat or a DC power supply with current logger to run bulk electrolysis experiments..

Gas Chromatography. The electrolysis samples were analyzed using a gas chromatograph (HP 5890 GC) equipped with a FID detector.

Ion Chromatography. The presence of formaldehyde and formic acid was also determined by the chromotropic acid assay.

Mass spectrometry. Mass spectral data was also collected to identify all organic compounds.

Nuclear Magnetic Resonance. NMR spectra of electrolyte volumes after bulk electrolysis were also obtained using an automated Bruker Ultrashield™ 500 Plus spectrometer.

[00062] The following Table may provide other examples of embodiments of the present invention.

Table 1

<u>Cathode</u>	<u>Catalyst</u>	<u>Electrolyte</u>	<u>Results</u>
Pt	10mM pyr	0.5M KCl	
Cu	10mM pyr	0.5M KCl	
SS2205 (E=-0.9V)	10mM pyr	0.5M KCl	IC: 0.44 % acetate + 0.14% formate (-0.9V), ~2% acetate (-0.4mA/cm <sup>2</sup> ) NMR: acetate
Ni625 (E=-0.8V)	10mM pyr	0.5M KCl	IC: acetate(0.04%). GC: Trace 1-Pyr-Al (0.002%) NMR: Me-OH
PdAg (-1.13V)	10mM pyr	0.1M CaCl <sub>2</sub>	IC: 2.3% acetate
PdAg (-1 V)	10mM pyr	0.1M CaCl <sub>2</sub>	IC: 69% acetate GC: trace 1-Bu-OH(~0.1%) NMR: acetate
NiCr (-1 V)	10mM pyr	0.5M KCl	IC: Acetate(<0.01%) GC: 0.44%IPA + 0.4% 1-Pyr-Al NMR: Et-OH
CoNiCr (-0.9 V)	10mM pyr	0.5M KCl	NMR: Me-OH
ss 316 (-1 V)	10mM pyr	0.1M TMAC	GC: 3% 1-pyr-OH, 0.2%Me-OH + 0.47%Bu-OH

Mo (-0.85 V)	10mM pyr	0.1M TMAC	IC: 0.25% Acetate GC: 0.15% 2-Bu-OH
Pb (-1.57 V)	10mM pyr	40 wt% TEAC	IC: 17% Formate and 0.2% glycolate GC: 0.3%Et-OH NMR: Et-OH
C (-1.6 V)	10mM pyr	40 wt% TEAC	IC: Trace Formate : 0.2% GC: 0.2% 1pyr-Al NMR: Et-OH
Bi (-1.33 V)	10mM pyr	40 wt% TEAC	IC: Trace Formate : 0.4% GC: 1.5%Me-OH + 0.08% Acetone NMR: Me-OH
SnPb (-1.46 V)	10mM pyr	40 wt% TEAC	IC: 7% Formate GC: 1.4%Et-OH + <1%acetone NMR: Et-OH
Pb	30mM 4- aminopyr	0.5M KCl high pH	
C (-1.6 V)	30mM 4- aminopyr	0.5M KCl high pH	IC: trace formate NMR: acetate
Bi (-1.2 V)	30mM 4- aminopyr	0.5M KCl high pH	IC: trace formate
SnPb (-1.46 V)	30mM 4- aminopyr	0.5M KCl high pH	IC: 0.88% acetate+1.64% formate NMR: Acetate
Pb -1.744V	-	0.1M TMAC-High pH	IC: 0.26% glycolate
Pb -1.944V	-	0.1M TMAC-High pH	IC: 4% formate + 0.1% glyolate NMR: Me-OH
C -0.945V	-	0.1M	IC: Trace Formate + 24% acetate

		<b>TMAC/TMAOH</b>	
<b>Pb</b> <b>-1.745V</b>	<b>-</b>	<b>0.1M</b>	<b>IC: Trace formate</b>
		<b>TMAC/MeOH</b>	
<b>C</b> <b>(-1.6 V)</b>	<b>10mM</b> <b>pyr</b>	<b>0.5M KCl</b>	<b>IC: Acetate (FY 1%)</b> <b>GC: 1 -Pyr-Al (0.0056%)</b> <b>NMR: acetate and Me-OH</b>
<b>Pb</b> <b>(-1.57 V)</b>	<b>10mM</b> <b>pyr</b>	<b>0.5M KCl</b>	<b>IC: formate(20%) + lactate (~0.58%FY)</b> <b>GC: MeOH ( 0.4%) +1 -Pyr-Al (0.08%)</b>
<b>Au</b> <b>(-1.07 V)</b>	<b>10mM</b> <b>pyr</b>	<b>0.5M KCl</b>	<b>IC: Trace formate</b>
<b>Zn</b> <b>(-1.5 V)</b>	<b>10mM</b> <b>pyr</b>	<b>0.5M KCl</b>	<b>IC: 5% formate</b> <b>GC: 0.026% 2-Bu-OH</b>
<b>Bi</b> <b>(-1.33 V)</b>	<b>10mM</b> <b>pyr</b>	<b>0.5M KCl</b>	<b>IC: 16% formate</b>
<b>In</b> <b>(-1.32 V)</b>	<b>10mM</b> <b>pyr</b>	<b>0.5M KCl</b>	<b>IC: 8% formate</b>
<b>Sn</b> <b>(-1.33 V)</b>	<b>10mM</b> <b>pyr</b>	<b>0.5M KCl</b>	<b>IC: 25% formate</b>
<b>SnAg</b> <b>(-1.33 V)</b>	<b>10mM</b> <b>pyr</b>	<b>0.5M KCl</b>	<b>IC: 11% formate</b> <b>GC: 4.45% acetone + 2.77% 1pyr-Al +</b> <b>0.15% Et-OH</b> <b>NMR: acetone</b>
<b>SnSb</b> <b>(-1.41 V)</b>	<b>10mM</b> <b>pyr</b>	<b>0.5M KCl</b>	<b>IC: 9% formate</b> <b>GC: 2.76% Me-OH</b> <b>NMR: acetate and MeOH</b>
<b>SnPb</b> <b>(-1.46 V)</b>	<b>10mM</b> <b>pyr</b>	<b>0.5M KCl</b>	<b>IC: 5% formate</b> <b>GC: 23% acetone</b> <b>NMR: acetone</b>

Ni625 (-1.13 V)	10mM pyr	0.5M KCl	IC: Trace Formate
Mo (-1 V)	10mM pyr	0.5M KCl	IC: Trace formate(< 0.1%)
PdAg (-0.87 V)	10mM pyr	0.5M KCl	GC: 0.04% Acetone+ 0.06% 2- Bu-OH NMR: acetate
NiFe (-1.1 V)	10mM pyr	0.5M KCl	IC: Trace formate<0.1%
ss316 (-0.94 V)	10mM pyr	0.5M KCl	NMR: Me-OH
ss304 (-0.97 V)	10mM pyr	0.5M KCl	IC: Trace oxlate,formate (~0.01% each), 3.97% acetate NMR: Me-OH and acetate
ss321 (-1 V)	10mM pyr	0.5M KCl	IC: 0.11% Oxlate, 0.17% acetate + trace Formate NMR: acetate and Me-OH
NiHX (-1 V)	10mM pyr	0.5M KCl	GC: 0.22% Me-OH + 0.01% 2-Bu-OH NMR: acetate
Rh (-0.85 V)	10mM pyr	0.5M KCl	GC: 0.57% Me-OH + 0.05% Acetone + 0.06% 2-Bu-OH NMR: acetate and Me-OH
Co (-1.08 V)	10mM pyr	0.5M KCl	IC: Trace formate + 0.19% acetate NMR: acetate
PtRh	10mM pyr	0.5M KCl	10% CE acetic acid with trace formic acid and methanol

ss304 (-0.7 V)	10mM pyr	0.5M KCl	2.2%acetate, 3.65% Me-OH
Rh (-0.65 V)	10mM pyr	0.5M KCl	0.8%- 12.6% acetate, .06%- 7.7% glycolate, 0.02-0.07% IPA, 0.005-1.09% Bu-OH, 0-0.41 % acetone
NiCr 60:16 (with Fe) (-0.7 V)	10mM pyr	0.5M KCl	IC: Trace fomate, 0.7% acetate
PdAg (-0.55 V)	10mM pyr	0.5M KCl	IC: Trace formate, 4% acetate
CoS (-1.2 V)	10mM pyr	0.5M KCl	IC: 0.3% FA, trace oxalate, 1.4% Acetate GC: Trace IPA, EtOH, acetone, prAL, 1-BuOH NMR: 1-BuOH, piperidine
MoS <sub>2</sub> (-1.4 V)	10mM pyr	0.5M KCl	IC: 1.1% FA, 0.02% Oxalate NMR: MeOH, (EtOH or BuOH)
TiB (-1.0 V)	10mM pyr	0.5M KCl	IC: 0.1% FA, 0.08% Oxalate, 0.005% glycolate
WS <sub>2</sub> (-1.0 V)	10mM pyr	0.5M KCl	IC: 0.2% FA, 1.6% acetate
SnS (-1.2 V)	10mM pyr	0.5M KCl	IC: 0.64% FA, 14% FY acetate GC: 0.77% acetone, 0.8% 1-BuOH NMR: MeOH, 1-BuOH, Propylene glycol
Ag <sub>2</sub> S (-1.2 V)	10mM pyr	0.5M KCl	IC: 0.04%FA, 2.8% acetate
CoP <sub>2</sub> (-1.2 V)	10mM pyr	0.5M KCl	IC: 0.2% FA, 0.005% oxalate, 4% acetate GC: trace 1-BuOH, acetone NMR: 2-BuOH, propylene glycol.

<b>Fe<sub>3</sub>P</b> (-1.1V or 5 mA)	<b>10mM</b> <b>pyr</b>	<b>0.5M KCl</b>	<b>IC: 0.27% FA, 1.5% Acetate</b> <b>GC: trace amounts of EtOH, acetone, PrAl</b> <b>NMR: EtOH, MeOH, acetone</b>
<b>Mn<sub>3</sub>P<sub>2</sub></b> (-1.0 V)	<b>10mM</b> <b>pyr</b>	<b>0.5M KCl</b>	<b>IC: 3% FY glycolate, 30% FY acetate, 0.6% FA</b> <b>GC: trace acetone PrAl</b>
<b>MoP</b> (-0.8 V)	<b>10mM</b> <b>pyr</b>	<b>0.5M KCl</b>	<b>IC: 0.32% FA, 35% acetate, 0.8% Oxalate</b> <b>GC: trace Acetone, MeOH</b> <b>NMR : MeOH, 1-BuOH</b>
<b>Ni<sub>2</sub>Si</b> (-1.0 V)	<b>10mM</b> <b>pyr</b>	<b>0.5M KCl</b>	<b>IC: 0.08% FA, 0.4% acetic</b>
<b>MoSi<sub>2</sub></b> (-1.0 V)	<b>10mM</b> <b>pyr</b>	<b>0.5M KCl</b>	
<b>WSi<sub>2</sub></b> (-1.0 V)	<b>10mM</b> <b>pyr</b>	<b>0.5M KCl</b>	<b>IC: 0.6%FA, 0.2% Glycolate, 4.5% Acetate</b>
<b>CoSi<sub>2</sub></b> (-1.1 V)	<b>10mM</b> <b>pyr</b>	<b>0.5M KCl</b>	<b>IC: 1.02% FA, 15.8% Acetate</b>
<b>Ebonex (TiO<sub>7</sub>)</b> (-1.0 V or 500uA)	<b>10mM</b> <b>pyr</b>	<b>0.5M KCl</b>	<b>IC: 4.3% FA, 99% acetate</b> <b>GC: 2.1% MeOH, 0.33% acetone, 1.2% 1-BuOH, 0.2% Butanone</b> <b>NMR: 1-butanol, propylene glycol, MeOH</b>
<b>SnO<sub>2</sub></b> (-1.0 V or 500 uA)	<b>10mM</b> <b>pyr</b>	<b>0.5M KCl</b>	<b>IC: 1.75% FA, 0.09% oxalate, 65% acetate</b> <b>GC: 0.5% Et-OH, 0.4% acetone, 0.3% IPA</b> <b>NMR: IPA, 1-BuOH, MeOH, propylene glycol</b>
<b>GaAs</b> (130uA/cm <sup>2</sup> )	<b>10mM</b> <b>pyr</b>	<b>0.5M KCl</b>	<b>IC: 12-23% CE acetic acid, 0.3-2% CE formic</b>
<b>p-GaAs</b>			<b>IC: 7.3% FA, 37.5% acetate</b>

(130uA/cm <sup>2</sup> )	10mM pyr	0.5M KCl	GC: 0.8% Et-OH, 0.19% acetone, 0.2% prAl, 1.32 IPA, 1.2 1-BuOH
p-GaAs epoxy control	10mM pyr	0.5M KCl	4ppm MeOH, 1ppm IPA, 0.2 ppm Et-OH, 0.15 ppm 2-BuOH
GaSb (-1.4 V)	10mM pyr	0.5M KCl	5% CE acetic acid, 0.6-4.5% formic acid
Ge (130uA/cm <sup>2</sup> )	10mM pyr	0.5M KCl	IC: 4-19% CE acetic acid, 0.6-1.2% CE formic GC: 0.4% IPA, 0.1 1-buOH NMR: propylene glycol, acetone
CdSe (-1.6 V)	10mM pyr	0.5M KCl	IC: 7% FA

[00063] The following tables provide additional examples of embodiments of the present invention. In particular, Table 2 shows faradaic efficiencies for formate (HCOO<sup>-</sup>) production, with a system employing a controlled potential electrolysis at -1.37V vs. SCE in CO<sub>2</sub> saturated water with a 0.5M KCl electrolyte. The catalyst concentration in the cathode compartment was 30mM. The anode compartment contained water with 0.17M K<sub>2</sub>SO<sub>4</sub>. The electrolysis was carried out in a three chambered glass cell with separated cathode and anode chambers. Carbon dioxide was continuously bubbled on the cathode chamber. In Table 2, j(mA/cm<sup>2</sup>) represents average current density, and FY(%) represents Faradaic Yield, which was calculated from the ppm of the formate measured by IC analysis on the catholyte solution collected after the electrolysis, and the total charge passed during the electrolysis.

Table 2

Catalysts	Time (hrs)	j(mA/cm <sup>2</sup> )	FY (%)
pyridine	6	0.78	20.4-21.6
4-picoline	6	1.96	19.3-39.1
Imidazole	6	0.26	1.7-4.8
2-picoline	6	1.02	36.4-42.2
2,6-Lutadine	6	0.73	30-43.8
Benzamidazole	6	0.32	0.4-1.0
2,2'-bipyridine	6	0.07	1.7-3.1
Nicotinic acid	6	0.21	13.2-13.3

[00064] Table 3 illustrates faradaic efficiencies for formate production using tin cathodes with 30mM 2-picoline catalyst in the cathode compartment, with various electrolytes. The electrolytes were saturated with carbon dioxide and present in 0.5M concentrations.

Table 3

Electrolytes	pH	HCOO <sup>-</sup> FY (%)
KCl	6.0	40.0
LiCl	5.9	30.1
CsCl	5.8	40.1
NH <sub>4</sub> Cl	5.9	34.8
Na <sub>2</sub> B <sub>4</sub> O <sub>7</sub> ·10H <sub>2</sub> O	6.0	0.7
NaH <sub>2</sub> PO <sub>4</sub>	6.0	26.4
NaClO <sub>4</sub>	5.74	34.5

[00065] Table 4 illustrates faradaic efficiencies for formate production using tin cathodes obtained from electrolysis in a divided H-Cell, with a controlled potential at -1.37V vs. SCE, in SCE in CO<sub>2</sub> saturated water with a 0.5M KCl electrolyte. The cathode compartment included a catalyst of 30mM 2-picoline, with the anode compartment including water with 0.17M K<sub>2</sub>SO<sub>4</sub>. The cathode compartment and anode compartment were separated by a proton exchange membrane (Selemion HSF). The pH was monitored continuously *in situ* by a glass electrode immersed in the cathode compartment.

Table 4

Time (hr)	pH <sup>b</sup>	j/(mA/cm <sup>2</sup> )	FY (%)
3	6.0	0.80	42.0
22	5.88	0.31	40.7
30	5.94	0.26	41.3
47	-----	0.17	38.4
53	-----	0.13	39.4
77	5.93	0.11	38.5
145	5.97	0.08	43.0

[00066] Table 5 illustrates the effects of 2-picoline concentrations on faradaic efficiencies for formate production using tin electrodes. Without use of 2-picoline as a catalyst, the average faradaic yield may be about 25% for the electrolysis in the CO<sub>2</sub> saturated KCl solution.

Table 5

[2- picoline]	Electrolyte	FY (%)
1mM	0.5M KCl	37.7
5mM	0.5M KCl	40.5
30mM	0.5M KCl	40.0
100mM	0.5M KCl	28.6

[00067] Table 6 illustrates the effects of pH for formate production using tin cathodes. The pH was adjusted using HCl or KOH solution after saturating with CO<sub>2</sub>.

Table 6

Electrolytes	pH	FY (%)
0.5M KCl	3	27
0.5MKCl	4	30
0.5MKCl	5	28
0.5MKCl	6	40

[00068] Table 7 illustrates faradaic efficiencies for formate production using tin cathodes buffered at 4.5 pH. The system employed a controlled potential electrolysis (-1.37V vs. SCE) in CO<sub>2</sub> saturated 0.5M KCl prepared in 0.2M phosphate buffer pH 4.5 (Alfa Aesar). The catalyst in the cathode compartment was 1mM 2-picoline, with 0.17M K<sub>2</sub>SO<sub>4</sub> in the anode compartment. The cathode compartment and anode compartment were separated by a proton exchange membrane.

Table 7

Time(hr)	pH		j (mA/cm <sup>2</sup> )		FY (%)	
	<i>With 2-picoline</i>	<i>Without 2-picoline</i>	<i>With 2-picoline</i>	<i>Without 2-picoline</i>	<i>With 2-picoline</i>	<i>Without 2-picoline</i>
3	4.69	4.86	1.16	3.94	37.1	5.8
6.5	4.71	5.10	1.08	3.01	30.0	2.4
23	4.55	5.17	0.97	2.90	28.5	3.0
28	4.57	-----	1.01	-----	33.5	----

**[00069]** Table 8 illustrates faradaic efficiencies for formate production using tin cathodes in water with an electrolyte including 0.25M KCl and 0.25M CsCl. The cathode compartment included 30mM 2-picoline as a homogenous catalyst. The system employed a controlled potential electrolysis (-1.37V vs. SCE) in CO<sub>2</sub> saturated 0.5M KCl. The anode compartment included 0.17M K<sub>2</sub>SO<sub>4</sub>. The cathode compartment and anode compartment were separated by a proton exchange membrane. Without use of 2-picoline as a catalyst, the average faradaic yield may be about 17.2% for the electrolysis in the CO<sub>2</sub> saturated KCl and CsCl solution.

Table 8

Time (hrs)	pH	(mA/cm <sup>2</sup> )	FY (%)
24	5.98	0.26	44.9
30	5.98	0.25	63.8
96	6.1	0.14	45.2

**[00070]** Carbon dioxide may be efficiently converted to value-added products, using either a minimum of electricity (that may be generated from an alternate energy source) or directly using visible light. Some processes described above may generate high energy density fuels that are not fossil-based as well as being chemical feedstock that are not fossil or biologically based. Moreover, the catalysts for the processes may be substituents-sensitive and provide for selectivity of the value-added products.

**[00071]** By way of example, a fixed cathode (e.g., stainless steel 2205) may be used in an electrochemical system where the electrolyte and/or catalyst are altered to change the product mix. In a modular electrochemical system, the cathodes may be swapped out with different materials to change the product mix. In a hybrid photoelectrochemical system, the anode may use different photovoltaic materials to change the product mix.

**[00072]** Some embodiments of the present invention generally provide for new cathode

materials, new electrolyte materials and new sulfur and oxygen-containing heterocyclic catalysts. Specific combinations of cathode materials, electrolytes, catalysts, pH levels and/or electrical potentials may be used to get a desired product. The organic products may include, but are not limited to, acetaldehyde, acetone, carbon, carbon monoxide, carbonates, ethanol, ethylene, formaldehyde, formic acid, glyoxal, glyoxylic acid, graphite, isopropanol, methane, methanol, oxalate, oxalic acid. Inorganic products may include, but are not limited to, polymers containing carbon dioxide. Specific process conditions may be established that maximize the carbon dioxide conversion to specific chemicals beyond methanol.

**[00073]** Cell parameters may be selected to minimize unproductive side reactions like H<sub>2</sub> evolution from water electrolysis. Choice of specific configurations of heterocyclic amine pyridine catalysts with engineered functional groups may be utilized in the system 100 to achieve high faradaic rates. Process conditions described above may facilitate long life (e.g., improved stability), electrode and cell cycling and product recovery. The organic products created may include methanol, formaldehyde, formic acid, glyoxal, acetone, and isopropanol using the same pyridine catalyst with different combinations of electrolytes, cathode materials, bubbling techniques and cell potentials. Heterocyclic amines related to pyridine may be used to improve reaction rates, product yields, cell voltages and/or other aspects of the reaction. Heterocyclic catalysts that contain sulfur or oxygen may also be utilized in the carbon dioxide reduction.

**[00074]** Some embodiments of the present invention may provide cathode and electrolyte combinations for reducing carbon dioxide to products in commercial quantities. Catalytic reduction of carbon dioxide may be achieved using steel or other low cost cathodes. High faradaic yields (e.g., >20%) of organic products with steel and nickel alloy cathodes at ambient temperature and pressure may also be achieved. Copper-based alloys used at the electrodes may remain stable for long-term reduction of carbon dioxide. The relative low cost and abundance of the combinations described above generally opens the possibility of commercialization of electrochemical carbon dioxide reduction.

**[00075]** Various process conditions disclosed above, including cathode materials, cathode surface morphology, electrolyte choice, catalyst choice, cell voltage, pH level and manner in which the carbon dioxide is bubbled, generally improve control of the reaction so that different products or product mixes may be made. Greater control over the reaction

generally opens the possibility for commercial systems that are modular and adaptable to make different products. The new materials and process conditions combinations generally have high faradaic efficiency and relatively low cell potentials, which allows an energy efficient cell to be constructed.

**[00076]** While the invention has been particularly shown and described with reference to the preferred embodiments thereof, it will be understood by those skilled in the art that various changes in form and details may be made without departing from the scope of the invention.

### CLAIMS

1. A method for reducing carbon dioxide to one or more products, comprising:
  - (A) bubbling said carbon dioxide into a solution of an electrolyte and a catalyst in a divided electrochemical cell, wherein (i) said divided electrochemical cell comprises an anode in a first cell compartment and a cathode in a second cell compartment, (ii) said cathode reducing said carbon dioxide into said products, and (iii) said cathode is selected from the group consisting of Al, Au, Ag, Bi, C, Cd, Co, Cr, Cu, a Cu alloy, Ga, Hg, In, Mo, Nb, Ni, NiCo<sub>2</sub>O<sub>4</sub>, a Ni alloy, a Ni-Fe alloy, Pb, Rh, Sn, a Sn alloy, Ti, V, W, Zn, elgiloy, Nichrome, austenitic steel, duplex steel, ferritic steel, martensitic steel, stainless steel, degenerately doped p-Si, degenerately doped p-Si:As, degenerately doped p-Si:B, degenerately doped n-Si, degenerately doped n-Si:As, degenerately doped n-Si:B, and mixtures thereof;
  - (B) adjusting one or more of (a) a cathode material, (b) a surface morphology of said cathode, (c) said electrolyte, (d) a manner in which said carbon dioxide is bubbled, (e), a pH level of said solution, and (f) an electrical potential of said divided electrochemical cell, to vary at least one of (i) which of said products is produced and (ii) a faradaic yield of said products; and
  - (C) separating said products from said solution.
2. The method according to claim 1, wherein said surface morphology of said cathode comprises a smooth surface.
3. The method according to claim 1, wherein said surface morphology of said cathode comprises a rough surface.
4. The method according to claim 1, wherein said catalyst is one or more of adenine, an amine containing sulfur, an amine containing oxygen, an azole, benzimidazole, a bipyridine, furan, an imidazole, an imidazole-related species with at least one five-member ring, an indole, methylimidazole, an oxazole, phenanthroline, pterin, pteridine, a pyridine, a pyridine-related species with at least one six-member ring, pyrrole, quinolone, and a thiazole.
5. The method according to claim 1, wherein said products comprise one or more of acetaldehyde, acetate, acetic acid, acetone, 1-butanol, 2-butanol, 2-butanone, carbon,

carbon monoxide, carbonates, ethane, ethanol, ethylene, formaldehyde, formate, formic acid, glycolate, glycolic acid, glyoxal, glyoxylate, glyoxylic acid, graphite, isopropanol, lactate, lactic acid, methane, methanol, oxalate, oxalic acid, a polymer containing carbon dioxide, 1-propanal, 1-propanol, and propionic acid.

6. The method according to claim 1, wherein said electrolyte is at least one of  $\text{Na}_2\text{SO}_4$ ,  $\text{KHCO}_3$ ,  $\text{KCl}$ ,  $\text{NaNO}_3$ ,  $\text{NaCl}$ ,  $\text{NaF}$ ,  $\text{NaClO}_4$ ,  $\text{KClO}_4$ ,  $\text{K}_2\text{SiO}_3$ ,  $\text{CaCl}_2$ , a guanidinium cation, a H cation, an alkali metal cation, an ammonium cation, an alkylammonium cation, a halide ion, an alkyl amine, a borate, a carbonate, a guanidinium derivative, a nitrite, a nitrate, a phosphate, a polyphosphate, a perchlorate, a silicate, a sulfate, and a tetraalkyl ammonium salt.

7. The method according to claim 6, further comprising:  
introducing to said solution of said electrolyte at least one of a divalent cation including at least one of calcium, magnesium, or zinc.

8. The method according to claim 1, wherein said manner in which said carbon dioxide is bubbled comprises:  
bubbling said carbon dioxide to contact said cathode.

9. The method according to claim 1, wherein said manner in which said carbon dioxide is bubbled comprises:  
bubbling said carbon dioxide to avoid contact with said cathode.

10. The method according to claim 1, wherein said pH level is between approximately 1 and approximately 8.

11. The method according to claim 1, wherein said electrical potential is between approximately -0.7 volts and -2 volts.

12. The method according to claim 1, wherein said stainless steel includes at least one of SS 2205, SS 304, SS 316, and SS 321; and wherein said Sn alloy includes at least one of SnAg, SnPb, SnSb.

13. A method for reducing carbon dioxide to one or more products, comprising:

(A) bubbling said carbon dioxide into a solution of an electrolyte in a divided electrochemical cell, wherein (i) said divided electrochemical cell comprises an anode in a first cell compartment and a cathode in a second cell compartment, (ii) said cathode reducing said carbon dioxide into said products, and (iii) said cathode is selected from the group consisting of p-GaAs, p-GaP, p-InN, p-InP, p-CdTe, p-GaInP<sub>2</sub>, p-Si, n-GaP, n-InN, n-InP, n-CdTe, n-GaInP<sub>2</sub>, n-Si, CoS, MoS<sub>2</sub>, TiB, WS<sub>2</sub>, SnS, Ag<sub>2</sub>S, CoP<sub>2</sub>, Fe<sub>3</sub>P, Mn<sub>3</sub>P<sub>2</sub>, MoP, Ni<sub>2</sub>Si, MoSi<sub>2</sub>, WSi<sub>2</sub>, CoSi<sub>2</sub>, TiO<sub>7</sub>, SnO<sub>2</sub>, n-GaAs, n-GaSb, n-Ge, n-CdSe, and mixtures thereof;

(B) adjusting one or more of (a) a cathode material, (b) a surface morphology of said cathode, (c) said electrolyte, (d) a manner in which said carbon dioxide is bubbled, (e), a pH level of said solution, and (f) an electrical potential of said divided electrochemical cell, to vary at least one of (i) which of said products is produced and (ii) a faradaic yield of said products; and

(C) separating said products from said solution.

14. The method of claim 13, further comprising a homogenous catalyst in the second cell compartment.

15. The method according to claim 14, wherein said homogenous catalyst is one or more of adenine, an amine containing sulfur, an amine containing oxygen, an azole, benzimidazole, a bipyridine, furan, an imidazole, an imidazole-related species with at least one five-member ring, an indole, methylimidazole, an oxazole, phenanthroline, pterin, pteridine, a pyridine, a pyridine-related species with at least one six-member ring, pyrrole, quinolone, and a thiazole.

16. The method according to claim 13, wherein said surface morphology of said cathode comprises a smooth surface.

17. The method according to claim 13, wherein said surface morphology of said cathode comprises a rough surface.

18. The method according to claim 13, wherein said products comprise one or more of acetaldehyde, acetate, acetic acid, acetone, 1-butanol, 2-butanol, 2-butanone, carbon,

carbon monoxide, carbonates, ethane, ethanol, ethylene, formaldehyde, formate, formic acid, glycolate, glycolic acid, glyoxal, glyoxylate, glyoxylic acid, graphite, isopropanol, lactate, lactic acid, methane, methanol, oxalate, oxalic acid, a polymer containing carbon dioxide, 1-propanal, 1-propanol, and propionic acid.

19. The method according to claim 13, wherein said electrolyte is at least one of  $\text{Na}_2\text{SO}_4$ ,  $\text{KCl}$ ,  $\text{NaNO}_3$ ,  $\text{NaCl}$ ,  $\text{NaF}$ ,  $\text{NaClO}_4$ ,  $\text{KClO}_4$ ,  $\text{K}_2\text{SiO}_3$ ,  $\text{CaCl}_2$ , a guanidinium cation, a H cation, an alkali metal cation, an ammonium cation, an alkylammonium cation, a halide ion, an alkyl amine, a borate, a carbonate, a guanidinium derivative, a nitrite, a nitrate, a phosphate, a polyphosphate, a perchlorate, a silicate, a sulfate, and a tetraalkyl ammonium salt.

20. The method according to claim 13, wherein said manner in which said carbon dioxide is bubbled comprises:

bubbling said carbon dioxide to contact said cathode.

21. The method according to claim 13, wherein said manner in which said carbon dioxide is bubbled comprises:

bubbling said carbon dioxide to avoid contact with said cathode.

22. The method according to claim 13, wherein said pH level is between approximately 1 and approximately 8.

23. The method according to claim 13, wherein said electrical potential is between approximately -0.7 volts and -2 volts.

24. A system for electrochemical reduction of carbon dioxide, comprising:  
an electrochemical cell including:  
a first cell compartment;  
an anode positioned within said first cell compartment;  
a second cell compartment;  
a separator interposed between said first cell compartment and said second cell compartment, said second cell compartment containing an electrolyte;  
a cathode positioned within said second cell compartment, said cathode selected from the group consisting of n-GaAs, SS304, n-Ge, NiCo<sub>2</sub>O<sub>4</sub>, Rh, and mixtures thereof; and  
an energy source operably coupled with said anode and said cathode, said energy source configured to apply a voltage between said anode and said cathode to reduce carbon dioxide at said cathode to at least one of acetate, acetic acid, glycolate, and glycolic acid.

25. The system of claim 24, further including a homogenous catalyst in the second cell compartment.

26. A system for electrochemical reduction of carbon dioxide, comprising:  
an electrochemical cell including:  
a first cell compartment;  
an anode positioned within said first cell compartment;  
a second cell compartment;  
a separator interposed between said first cell compartment and said second cell compartment, said second cell compartment containing an electrolyte;  
a cathode and a homogenous catalyst positioned within said second cell compartment, said cathode comprising tin (Sn), said catalyst including at least one of pyridine, 2-picoline or 2,6-lutidine; and  
an energy source operably coupled with said anode and said cathode, said energy source configured to apply a voltage between said anode and said cathode to reduce carbon dioxide at said cathode to at least one of formate or formic acid.
27. The system of claim 26, wherein said catalyst is present in said second cell compartment in a concentration of between about 1mM and 100mM.
28. The system of claim 27, wherein said catalyst is present in said second cell compartment in a concentration of about 30mM.
29. The system of claim 26, wherein said second cell compartment further includes an acidic solution.
30. The system of claim 29, wherein said second cell compartment further includes a phosphate buffer.
31. The system of claim 30, wherein said phosphate buffer is a 0.2M phosphate buffer.
32. The system of claim 29, wherein said second cell compartment has a pH range of between about 1 and 7.
33. The system of claim 32, wherein said second cell compartment has a pH range of between about 3 and 6.

34. The system of claim 26, wherein said second cell compartment further includes a mixture of cations, said mixture of cations including at least one of a mixture of potassium ions and cesium ions, a mixture of lithium and potassium ions, a mixture of lithium and cesium ions, a mixture of sodium and cesium ions, or a mixture of lithium and sodium ions.

35. The system of claim 34, wherein said at least one of a mixture of potassium ions and cesium ions, a mixture of lithium and potassium ions, a mixture of lithium and cesium ions, a mixture of sodium and cesium ions, or a mixture of lithium and sodium ions includes a molar ratio of between about 1:1000 and 1000:1.

36. A method for reducing carbon dioxide to one or more organic products, comprising:

(A) introducing an anolyte to a first compartment of an electrochemical cell, said first compartment including an anode;

(B) introducing a catholyte and carbon dioxide to a second compartment of said electrochemical cell, said second compartment including a tin cathode and a catalyst, said catalyst including at least one of pyridine, 2-picoline or 2,6-lutidine; and

(C) applying an electrical potential between said anode and said cathode sufficient for said cathode to reduce said carbon dioxide to at least one of formate or formic acid.

37. The method of claim 36, wherein said catalyst is present in said second cell compartment in a concentration of between about 1mM and 100mM.

38. The system of claim 37, wherein said catalyst is present in said second cell compartment in a concentration of about 30mM.

39. The method of claim 36, further comprising:  
introducing an acidic solution to said second cell compartment.

40. The method of claim 39, further comprising:  
introducing a phosphate buffer to said second cell compartment.

41. The method of claim 40, wherein said phosphate buffer is a 0.2M phosphate buffer.

42. The method of claim 39, further comprising:  
maintaining said second cell compartment at a pH range of between about 1 and 7.

43. The method of claim 42, wherein maintaining said second cell compartment at a pH range of between about 1 and 7 includes:  
maintaining said second cell compartment at a pH range of between about 3 and 6.

44. The method of claim 36, further comprising:  
introducing a mixture of cations to said second cell compartment, said mixture of

cations including at least one of a mixture of potassium ions and cesium ions, a mixture of lithium and potassium ions, a mixture of lithium and cesium ions, a mixture of sodium and cesium ions, or a mixture of lithium and sodium ions.

45. The method of claim 44, wherein said at least one of a mixture of potassium ions and cesium ions, a mixture of lithium and potassium ions, a mixture of lithium and cesium ions, a mixture of sodium and cesium ions, or a mixture of lithium and sodium ions includes a molar ratio of between about 1:1000 and 1000:1.

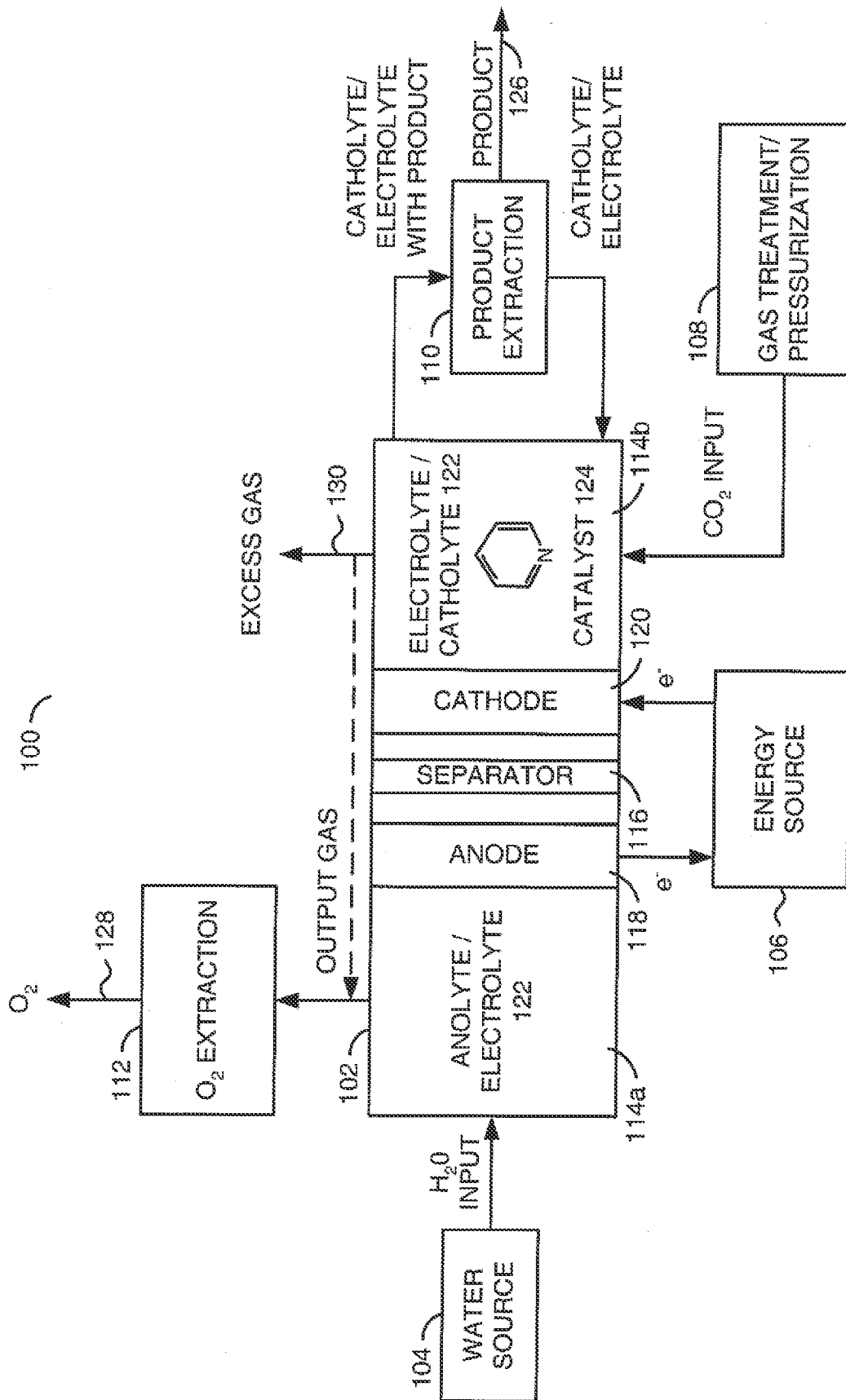

FIG. 1

PRODUCT	SYSTEM	CATALYST CONCENTRATION	ELECTROLYTE CONCENTRATION	CATHODE POTENTIAL	pH
CARBON MONOXIDE	Sn/PYRIDINE/KCl QUINOLINE ALSO EFFECTIVE	10 TO 100mM	0.25 TO 1M	-1 TO -1.4	5-7
CARBONATE	STEEL/IMIDAZOLE/KCl WITH CaCl <sub>2</sub>	10 TO 100mM	0.5M KCl W/ 0.1M CaCl <sub>2</sub>	-0.9 TO -1.2	4-7
FORMIC ACID	Sn/IMIDAZOLE/KCl OR STAINLESS STEEL/IMIDAZOLE/CsCl SUBSTITUTED IMIDAZOLES, THIAZOLES, AND ADENINE ALSO EFFECTIVE	10 TO 100mM	0.25 TO 1M	-0.8 TO -1.4	4-8
FORMALDEHYDE	ELGILOY/PYRIDINE/Na <sub>2</sub> SO <sub>4</sub>	10mM TO 100mM	0.25 TO 1M	-0.8 TO -1.2	4-7
METHANOL	Mo/PYRIDINE/ Na <sub>2</sub> SO <sub>4</sub>	10mM TO 100mM	0.25 TO 1M	-0.8 TO -1.2	4-7
OXALIC ACID	FERRITIC STEEL/IMIDAZOLE/CaCl <sub>2</sub>	10mM TO 100mM	0.25 TO 1M	-0.8 TO -1.2	5-7
GLYOXYLIC ACID	FERRITIC STEEL/IMIDAZOLE/KCl	10mM TO 100mM	0.25 TO 1M	-0.8 TO -1.2	5-7
GLYOXAL	Co/PYRIDINE/KCl	10mM TO 100mM	0.25 TO 1M	-0.8 TO -1.2	5-7
ACETALDEHYDE	Ni ALLOYS/ PYRIDINE/ Na <sub>2</sub> SO <sub>4</sub>	10mM TO 100mM	0.25 TO 1M	-0.8 TO -1.2	4-7
ETHANOL	DUPLEX STEEL/ IMIDAZOLE/KCl	50mM TO 300mM	0.25 TO 1M	-0.8 TO -1	4-6
ACETONE	DUPLEX STEEL/ PYRIDINE/KCl	10mM TO 100mM	0.25 TO 1M	-0.8 TO -1	4-6
ISOPROPANOL	DUPLEX STEEL/ PYRIDINE/KCl, STAINLESS STEEL/ METHYLIMIDAZOLE/KCl, STAINLESS STEEL/ 2,2' BIPYRIDINE/KCl	10mM TO 100mM	0.25 TO 1M	-0.8 TO -1.2	4-8
POLYMERS	P-Si:As/PYRIDINE/Na <sub>2</sub> SO <sub>4</sub>	10mM TO 100mM	0.25 TO 1M	-1.6 TO -2	4-8

FIG. 2A

CATHODE-ELECTROLYTE COMBINATIONS  
(WITH 10mM PYRIDINE CATALYST)

CATHODE MATERIAL	ELECTROLYTE	REL YIELD ORGANICS
TIN (Sn)	Na <sub>2</sub> SO <sub>4</sub>	81% METHANOL, 19% FORMIC ACID
MOLYBDENUM (Mo)	KCl OR Na <sub>2</sub> SO <sub>4</sub>	100% METHANOL
COBALT (Co)	KCl	36% METHANOL, 74% FORMIC ACID
NICKEL (Ni)	KCl	50% METHANOL, 50% FORMIC ACID
CHROMIUM (Cr)	KCl	100% ACETONE
VANADIUM (V)	KCl	100% METHANOL
NIوبيUM (Nb)	KCl	100% FORMIC ACID
TUNGSTEN (W)	KCl	100% ACETONE
SILVER (Ag)	Na <sub>2</sub> SO <sub>4</sub>	54% METHANOL, 46% ACETONE
STAINLESS STEEL 304	Na <sub>2</sub> SO <sub>4</sub>	100% METHANOL
STAINLESS STEEL 316	Na <sub>2</sub> SO <sub>4</sub>	100% METHANOL
STAINLESS STEEL 316	KCl	100% FORMIC ACID
STAINLESS STEEL 430	KCl	X% GLYOXAL, Y% FORMIC ACID
STAINLESS STEEL 2205	Na <sub>2</sub> SO <sub>4</sub>	100% METHANOL
STAINLESS STEEL 2205	KCl	UP TO 99% ACETONE, 1% FORMIC ACID
NICHROME (80% Ni, 20% Cr)	KCl	100% ACETONE
Ni-Fe (45% Ni, 55% Fe)	Na <sub>2</sub> SO <sub>4</sub>	100% METHANOL
NICKEL 625 (INCONEL)	Na <sub>2</sub> SO <sub>4</sub>	100% METHANOL
NICKEL 625 (INCONEL)	KCl	99% ACETONE, 1% FORMIC ACID

FIG. 2B

CATHODE-ELECTROLYTE COMBINATIONS  
(WITH 10mM PYRIDINE CATALYST)

CATHODE MATERIAL	ELECTROLYTE	REL YIELD ORGANICS
NICKEL 600	KCl	55% METHANOL, 45% FORMIC ACID
NICKEL HX	Na <sub>2</sub> SO <sub>4</sub>	X% GLYOXAL, Y% METHANOL
NICKEL HX	KCl	100% FORMIC ACID
ELGILOY (Co, Ni, Cr)	Na <sub>2</sub> SO <sub>4</sub>	89% METHANOL, 11% FORMIC ACID
ELGILOY (Co, Ni, Cr)	KCl	95% ACETONE, 5% FORMIC ACID
BRASS 464 (39% Zn)	Na <sub>2</sub> SO <sub>4</sub>	81% METHANOL, 19% FORMIC ACID
BRONZE 510 (5% Sn)	Na <sub>2</sub> SO <sub>4</sub>	100% METHANOL
Cu-Mn-Ni	KCl	100% ACETONE
Cu-Ni	KCl	100% ACETONE
BRASS 260	KCl	100% ACETONE

FIG. 2C

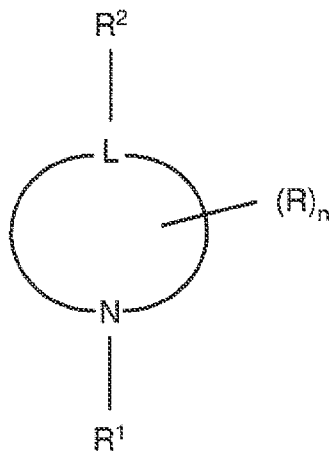

FIG. 3

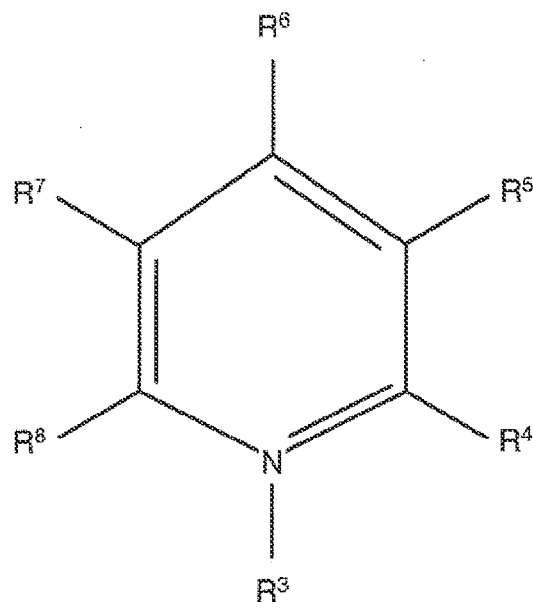

FIG. 4

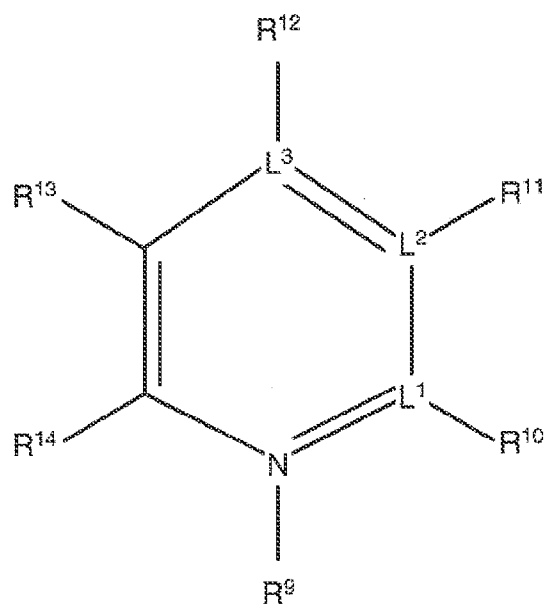

FIG. 5

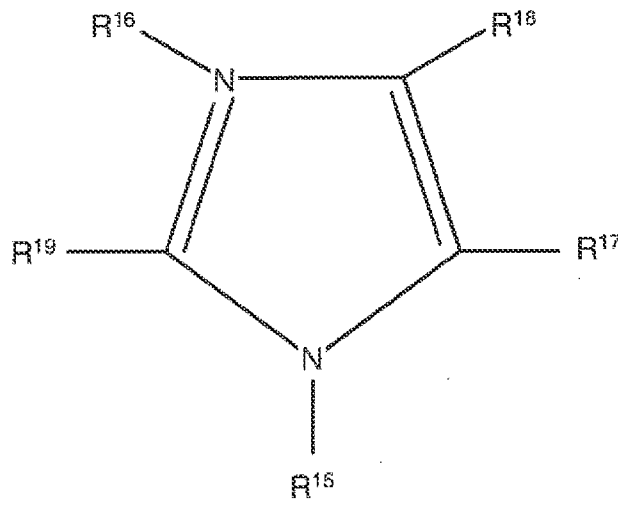

FIG. 6

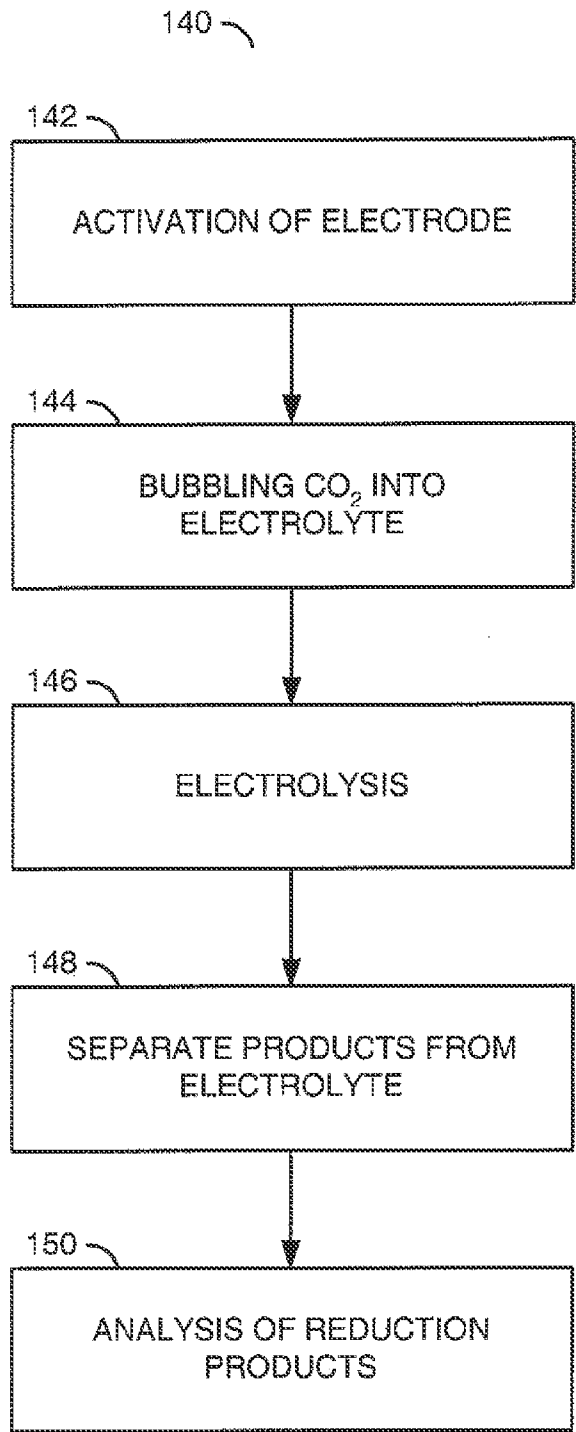

FIG. 7

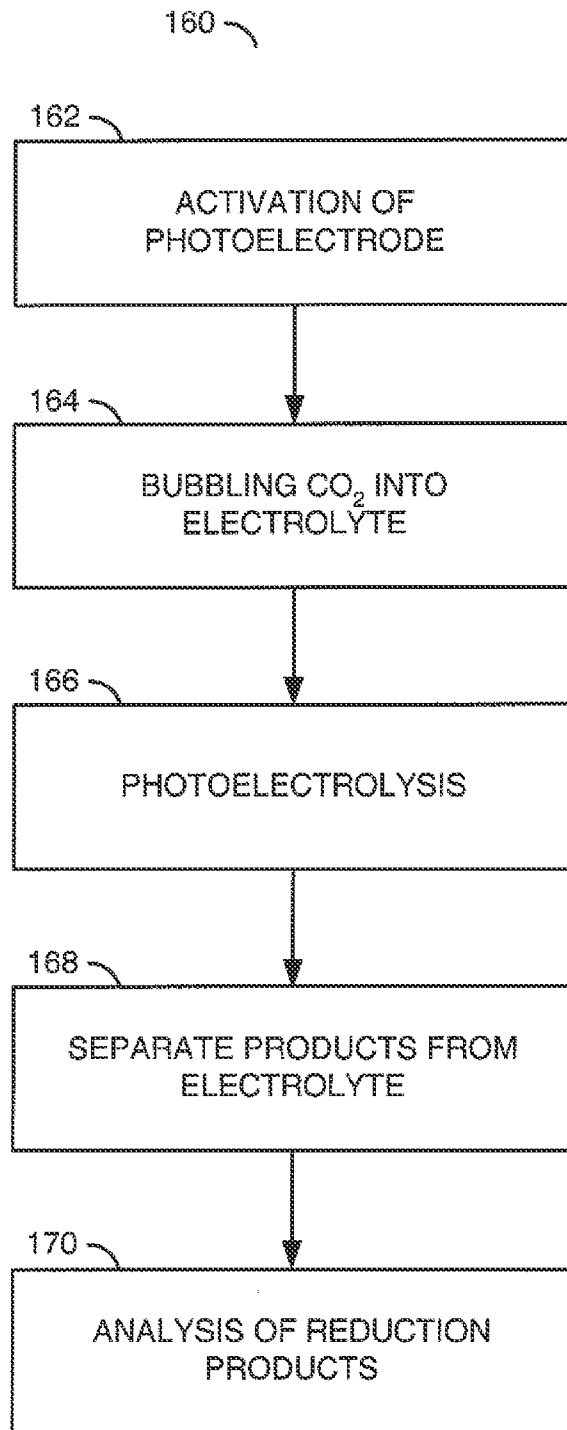

FIG. 8