

T. E. DILLEY.
 COMBINED VENTILATOR AND FLY ESCAPE.
 APPLICATION FILED MAY 24, 1909.

974,863.

Patented Nov. 8, 1910.

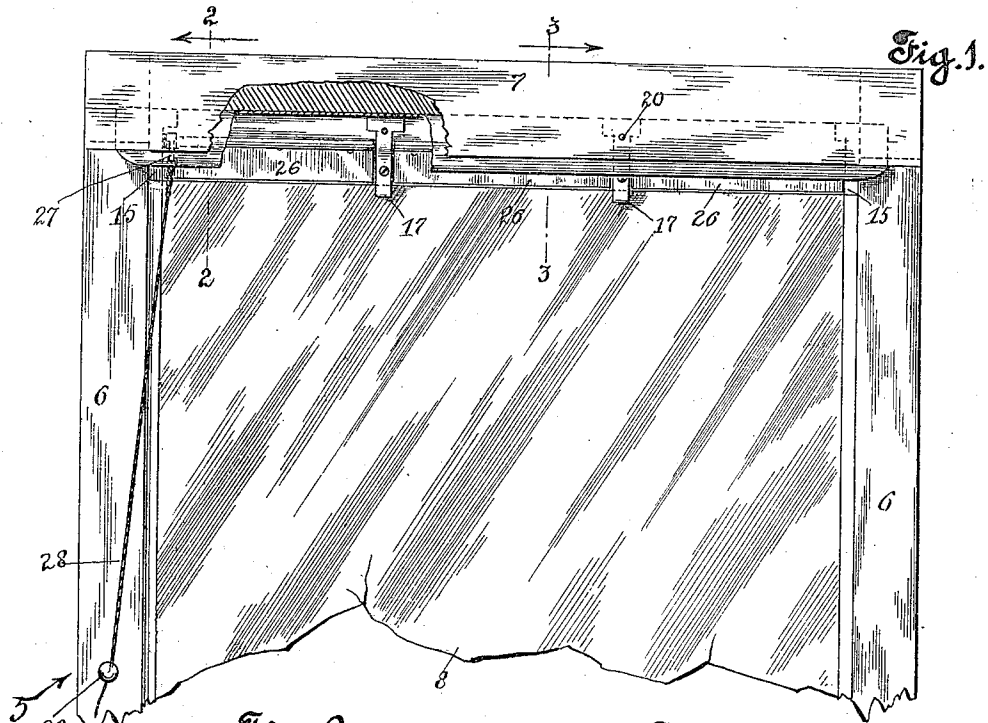

Fig. 2.

Fig. 3.

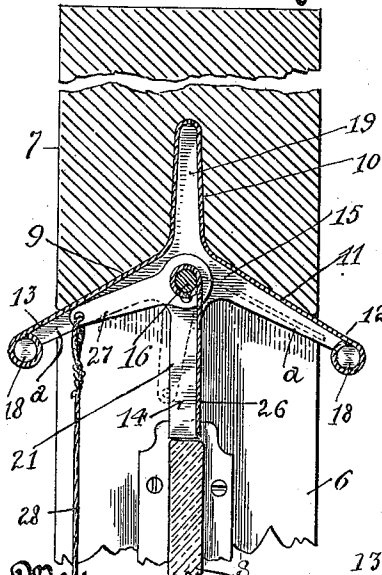
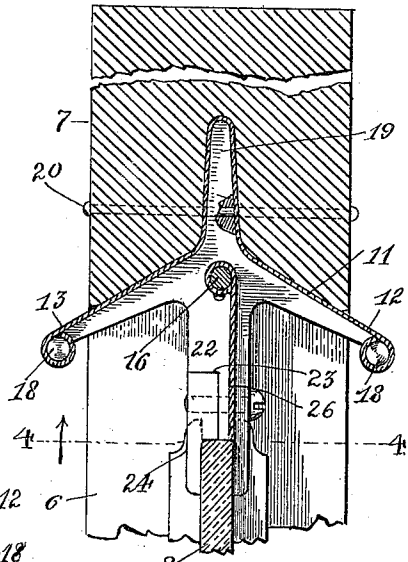
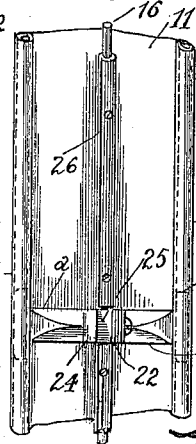

Fig. 4.



Witnesses,
W. Monteverde
 M. A. Palmer.

Inventor,
 Thomas E. Dilley,

Howard & House
 Attorneys

UNITED STATES PATENT OFFICE.

THOMAS E. DILLEY, OF LOS ANGELES, CALIFORNIA.

COMBINED VENTILATOR AND FLY-ESCAPE.

974,863.

Specification of Letters Patent.

Patented Nov. 8, 1910.

Application filed May 24, 1909. Serial No. 498,030.

To all whom it may concern:

Be it known that I, THOMAS E. DILLEY, a citizen of the United States, residing at Los Angeles, in the county of Los Angeles and State of California, have invented new and useful Improvements in Combined Ventilators and Fly-Escapes, of which the following is a specification.

This invention relates to a combined ventilator and fly escape designed to be secured to stationary window sashes, display windows and like structures, and a prime object thereof is to provide a ventilator that may be readily secured in place along the entire upper horizontal edge of a stationary window-frame, or show window, and that will effectually ventilate at all times the upper area of the room inclosed by the frame without exposing the room to untoward elements.

A further and important object is to provide a ventilator that may be readily adjusted to suit the varying temperatures, and that will provide a convenient means of exit for flies and other insects from the interior of the room to the outside thereof.

I accomplish the above objects by means of the device described herein and shown in the accompanying drawings, in which:—

Figure 1— is a partial front elevation of a stationary window frame provided with my improved ventilator, parts being broken away and parts in section to disclose the construction. Fig. 2— is an enlarged cross section taken on line 2—2 of Fig. 1. Fig. 3— is a view similar to Fig. 2, but taken on line 3—3 of Fig. 1. Fig. 4— is a partial plan view on a reduced scale of the ventilator frame and supports therefor taken on line 4—4 of Fig. 3.

In a practical embodiment of my invention, 5 designates a stationary window sash, consisting of vertical rails or side-pieces 6 that are joined together at the top thereof by a horizontally disposed lintel rail or plate 7, in the lower edge of which my improved ventilator is mounted, as will be more particularly described hereinafter. Frame 5 is supplied with the usual glass pane 8, that extends from the bottom upwardly to within a short distance of the top of the frame, as clearly illustrated in the various views of the drawings. Lintel 7 is grooved as at 9 on its under face from its two lower edges toward the center in a general inverted V-shape. At the apex of the groove 9 a sec-

ond substantially wedge-shaped groove 10 opens into the first, this groove being designed to accommodate the upper fingers of a plurality of preferably metal bearings that will be described later on. The faces of grooves 9 and 10 are provided with a protective metal sheathing or hood 11 that extends beyond the inner and outer faces of the lintel 8 to form a storm shield 12 on the outside, and a shield and finish 13 for the inside of the frame. The inside shield also acts as a means of guiding insects, such as flies, out through the opening 14 formed at the top of the glass pane. The metal sheathing preferably extends the entire length of the groove, and the ends are secured to the vertical side rails in the manner illustrated in Fig. 1. On its central axis the sheathing is bent to form a longitudinal tongue 12^a received in groove 10.

Mounted adjacent each side rail is a bearing 15, preferably formed of a non-corrosive metal, such as brass or aluminum. These bearings or brackets are designed to support a rotatively mounted shaft 16, other bearings 17 being provided at suitable intervals, the number depending entirely upon the length of the opening 14. Bearings 15 are preferably of the configuration shown in Fig. 2 of the drawings, the laterally extending arms *a* terminating in circular ends 18 that are engaged by the rolled outer edges of the metal shields and rigidly supporting them. These bearings are also provided with upwardly extending arms 19 that enter groove 10, transversely disposed pins 20 securing them in rigid engagement with the groove and metal facing. The bearings are also provided with downwardly extending arms 21 that rest against the upper edge of glass 8. Intermediate bearings 17 are similar to bearings 15, except that the lower central arms 22 are provided with bearing shoulders 23 that form with blocks 24, that are held in screw-threaded engagement therewith, a groove 25 for the reception of the upper edge of the glass pane. Shaft 16, as heretofore stated, extends the entire length of the opening 14 and is provided with a closure or shutter 26, preferably formed of aluminum, or other non-corrosive metal, and rigidly secured to the shaft in any suitable manner. The lower horizontal edge of closure 26 contacts with the upper edge of the glass pane, so as to close the opening 14. Closure 26 is here illustrated as consisting

of a number of wings interposed between the bearings, but if the space between the side rails is comparatively short, bearings 17 may be dispensed with and the closure 26
5 may be formed in one part. At one end of the shaft, and rigidly secured thereto, is an operating arm 27 from which depends a cord 28 that is secured to a button 29 mounted on rail 6. It will be observed that by
10 securing the arm 27 rigidly to the shaft and at an angle to the closure 26, that by a simple pull on cord 28 the closure may be adjusted at any desired angle.

From the foregoing description it will be
15 apparent that I have produced a novel form of ventilator and fly escape, by means of which the interior of a room or show-window may be efficiently ventilated, and which will effectually rid the room or window of flies,
20 or other insects that may be therein.

It is well known that flies in a room usually congregate around the window where there is light and warmth, and also that they usually seek the higher levels, crawling upwardly on the glass pane. By locating my
25 improved ventilator at the upper edge of the window, the flies that crawl upwardly will naturally make their exit therethrough.

Having described my invention what I
30 claim as new and desire to secure by Letters Patent is:—

1. A window frame having a lintel, a pane of glass mounted in said frame arranged with its upper edge disposed below
35 said lintel and removed from said lintel, said edge extending completely across said window frame whereby a ventilating opening is formed under said lintel, and a shutter attached at the upper edge to said lintel
40 normally lying in the same plane with said pane adapted to swing laterally and adapted to have its lower edge lie adjacent to the upper edge of said pane to close said ventilating opening the upper edge of said pane
45 forming the lower edge of said opening.

2. The combination of a window-frame provided with an opening therein at the top thereof, of a ventilator mounted in said
50 opening, said ventilator comprising a transversely extending metallic frame secured in said opening at the top thereof, a plurality of bearings mounted in said frame, said bearings mounted transversely of said opening and engaging the material forming the
55 lower edge of the opening, a shaft revolubly mounted in said bearings at the top of said opening, a closure rigidly secured to said shaft and operating therewith, and an arm provided with a pull cord rigidly secured
60 to said shaft and adapted to operate said closure.

3. A window-frame having a lintel, a ventilator attached to the under side of said lintel and having a laterally projecting

shield, a pane of glass mounted in said
65 frame and having its upper edge disposed below said lintel whereby a ventilator opening is formed, brackets in connection with said ventilator having downwardly extending arms engaging the upper edge of said
70 pane of glass, and a ventilator shutter rotatably mounted in said brackets and adapted to close said opening.

4. A window-frame having a lintel with a groove therein extending upwardly from
75 the under face thereof, a ventilator having a tongue disposed in said groove and forming shields on the under side of said lintel below said groove, fastening devices passing in a substantially horizontal plane
80 through said lintel and engaging said tongue to secure said ventilator to said lintel, and a shutter movably mounted on said ventilator under said lintel.

5. A window-frame having a lintel with
85 a longitudinal groove in the under side thereof, a ventilator in the form of a plate having a longitudinally extending tongue on the upper side thereof seating in said groove, and having shields extending laterally
90 at the lower portion thereof, brackets to which said ventilator plate attaches, a pane of glass mounted in said window frame and having its upper edge disposed below said ventilator whereby an opening is
95 formed, said brackets having arms receiving the upper edge of said pane, and a shutter rotatably mounted in said brackets and adapted to close said opening.

6. A window-frame having a lintel, a ventilator comprising a plate seating against the
100 under side of said lintel, brackets in connection with said plate having outwardly extending arms reinforcing said plate, a pane of glass mounted in said frame and
105 having its upper edge disposed below said lintel whereby an opening is formed, said brackets having arms extending downwardly in said opening and attached to the upper edge of said pane, a shaft rotatably mounted
110 in said brackets and a shutter carried by said shaft adapted to close said opening.

7. The combination of a window-frame having a lintel, of a ventilator attached to
115 the under side of said lintel, said ventilator comprising oppositely disposed parts projecting beyond both faces of the window-frame to form shields, a shutter mounted in said ventilator in a vertical plane under said lintel and adapted to close said ventilator,
120 and means to operate said shutter.

In witness that I claim the foregoing I have hereunto subscribed my name this 11th day of May, 1909.

THOS. E. DILLEY.

Witnesses:

EDMUND A. STRAUSE,
MYRTLE A. PALMER.