



- (51) International Patent Classification:
F02M 51/06 (2006.01) F02M 63/00 (2006.01)
- (21) International Application Number:
PCT/EP2012/059616
- (22) International Filing Date:
23 May 2012 (23.05.2012)
- (25) Filing Language: English
- (26) Publication Language: English
- (30) Priority Data:
11167084.0 23 May 2011 (23.05.2011) EP
- (71) Applicant (for all designated States except US): **CONTINENTAL AUTOMOTIVE GMBH** [DE/DE]; Vahrenwalder Straße 9, 30165 Hannover (DE).
- (72) Inventors; and
- (75) Inventors/Applicants (for US only): **GRANDI, Mauro** [IT/IT]; Viale Città del Vaticano N°44, I-57128 Livorno (IT). **POLIDORI, Valerio** [IT/IT]; Via Grecia 35, I-57128 Livorno (IT). **MANNUCCI, Cristiano** [IT/IT]; Via G. Lomi 74, I-57124 Livorno (IT).

(74) Common Representative: **CONTINENTAL AUTOMOTIVE GMBH**; Postfach 22 16 39, 80506 München (DE).

(81) Designated States (unless otherwise indicated, for every kind of national protection available): AE, AG, AL, AM, AO, AT, AU, AZ, BA, BB, BG, BH, BR, BW, BY, BZ, CA, CH, CL, CN, CO, CR, CU, CZ, DE, DK, DM, DO, DZ, EC, EE, EG, ES, FI, GB, GD, GE, GH, GM, GT, HN, HR, HU, ID, IL, IN, IS, JP, KE, KG, KM, KN, KP, KR, KZ, LA, LC, LK, LR, LS, LT, LU, LY, MA, MD, ME, MG, MK, MN, MW, MX, MY, MZ, NA, NG, NI, NO, NZ, OM, PE, PG, PH, PL, PT, QA, RO, RS, RU, RW, SC, SD, SE, SG, SK, SL, SM, ST, SV, SY, TH, TJ, TM, TN, TR, TT, TZ, UA, UG, US, UZ, VC, VN, ZA, ZM, ZW.

(84) Designated States (unless otherwise indicated, for every kind of regional protection available): ARIPO (BW, GH, GM, KE, LR, LS, MW, MZ, NA, RW, SD, SL, SZ, TZ, UG, ZM, ZW), Eurasian (AM, AZ, BY, KG, KZ, RU, TJ, TM), European (AL, AT, BE, BG, CH, CY, CZ, DE, DK, EE, ES, FI, FR, GB, GR, HR, HU, IE, IS, IT, LT, LU, LV, MC, MK, MT, NL, NO, PL, PT, RO, RS, SE, SI, SK, SM,

[Continued on next page]

(54) Title: INJECTOR FOR INJECTING FLUID

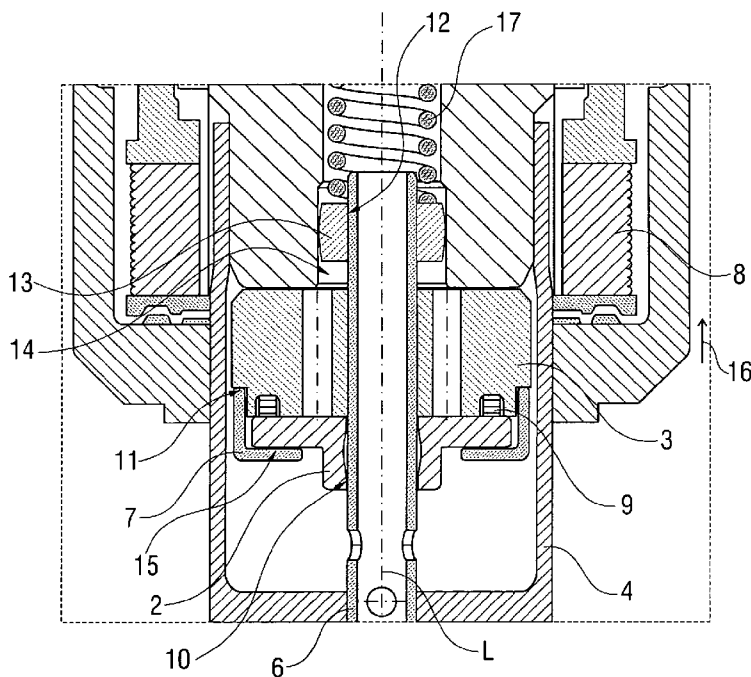

FIG 2

(57) Abstract: An injector for injecting fluid, comprises - a valve needle (6), being axially moveable with respect to a valve body (4) and being operable to prevent a fluid injection in a closing position and to permit the fluid injection in an open position, - an armature (3) for moving the valve needle (6) in a first direction (16) from the closing position towards the open position, - a needle retainer (2) that is fixed to the valve needle (6), - an armature holder (7) that is fixed to the armature (3), - the needle retainer (2) and the armature holder (2) are releasably coupleable such that when the armature (3) moves in the first direction (16) the needle (6) is moved in the first direction (16) by the movement of the armature holder (7) and the needle retainer (2).

WO 2012/160100 A1

TR), OAPI (BF, BJ, CF, CG, CI, CM, GA, GN, GQ, GW, ML, MR, NE, SN, TD, TG). **Published:**

— with international search report (Art. 21(3))

Description

Injector for injecting fluid

5 The invention relates to an injector for injecting fluid and relates particularly to an injector for injecting fuel into an internal combustion engine.

10 Injection valves are in widespread use, in particular for internal combustion engines where they may be arranged in order to dose the fluid into an intake manifold of the internal combustion engine or directly into the combustion chamber of a cylinder of the internal combustion engine.

15 Injection valves are manufactured in various forms in order to satisfy the various needs for the various combustion engines. Therefore, for example, their length, their diameter and also various elements of the injection valve being responsible for the way the fluid is dosed may vary in a wide range. In addition to
20 that, injection valves may accommodate an actuator for actuating a valve needle of the injection valve, which may, for example, be an electromagnetic actuator.

25 In order to enhance the combustion process in view of the creation of unwanted emissions, the respective injection valve may be suited to dose fluids under very high pressures. The pressures may be in case of a gasoline engine, for example, in the range of up to 200 bar and in the case of diesel engines in the range of up to 2000 bar.

30

After a desired injection during the injector closing phase a post injection can occur caused by an injector reopening. Current injector design includes very often a needle armature de-coupled feature. This design increases the impact between armature and

upper armature retainer and also allows the needle to have the so called needle overshoot behavior. The needle overshoot happens during the injector standard operating mode: there is a needle overshoot during the needle opening phase. The needle overshoot during the opening phase occurs after that the armature impacts the pole piece impact face. When the armature stops and bounces against the pole piece impact face, the needle continues its motions by the effect of its inertia. By means of this phenomenon the opening phase is controlled for the armature but it is not controlled for the needle. Since the needle movement is responsible for fuel delivery, it happens that just at the end of the opening phase the needle is not in a controlled position in respect to the injector seat. This is unfavorable injector behavior and it impacts in particular way the minimum controllable deliverable flow. Due to the opening phase needle overshoot behavior, the minimum controllable flow quantity is increased. During the closing phase the armature overshoot occurs in the opposite direction, the armature detaches from the armature upper retainer and compresses the anti bounce spring eliminating the needle bounce at closing. Once that the anti bounce spring is compressed it releases the stored energy pushing again the armature against the upper armature retainer generating the unwanted and uncontrolled operating condition of the so called post injection.

25

The object of the invention is to provide an injector for injecting fluid that works reliably.

30

According to an aspect, the invention is characterized by an injector for injecting fluid. The injector comprises a valve needle being axially movable relative to a valve body. The valve needle is operable to prevent the fluid injection in a closing position and to permit the fluid injection in an open position. The injector further comprises an armature for moving the valve

needle in a first direction from the closing position towards the open position. The injector further comprises a needle retainer that is fixed to the valve needle, and an armature holder that is fixed to the armature. The needle retainer and the armature holder are releasably coupleable such that when the armature moves in the first direction, the needle is moved in the first direction by the movement of the armature holder and the needle retainer.

10 The armature holder and the needle retainer are arranged such that the armature holder is able to apply a compressive force to the needle retainer. The armature holder is arranged to affect a pressure on the needle retainer. The armature holder and the needle retainer are arranged such that the armature holder cannot
15 apply a tractive force or a tension force to the needle retainer. The armature holder and the needle retainer are arranged such that the needle retainer needs to follow a movement of the armature holder in the first direction. The armature holder and the needle retainer are arranged such that the needle retainer is not forced
20 to follow a movement in a second direction in the direction opposite the first direction of the armature holder. The armature holder pulls the needle retainer during the movement in the first direction. Due to the arrangement of the armature holder and the needle retainer with respect to each other, the overshoot of the
25 armature and the needle during the opening and the closing phase is reduced. A maximum achievable overshoot is controllable.

According to further aspects, the armature holder and the needle retainer each are realized with a cross-section in an L-form. The
30 form of the armature holder and the form of the needle retainer correspond to each other. The armature holder and the needle retainer are formed such that the armature holder and the needle retainer comprise a common contact area. Therefore, the contact surfaces of the moving parts are larger and therefore, the contact

pressure is reduced. The armature holder and the needle retainer therefore need no protective coating in the contact area.

The armature holder is fixed to the armature such that the
5 armature holder moves when the armature moves. According to
further aspects, the armature holder is welded to the armature
such that the injector comprises a welded connection between the
armature holder and the armature to fix the armature holder to
the armature. The injector further comprises a welded connection
10 between the needle retainer and the valve needle to fix the needle
retainer to the valve needle. The needle retainer is welded to
the valve needle such that the valve needle needs to follow a
movement of the needle retainer.

15 According to further aspects, the injector comprises a spring
that is arranged between the needle retainer and the armature.

In the following, embodiments of the invention are illustrated
with reference to the schematic drawings. Elements of the same
20 construction or function are provided with the same reference
sign throughout the figures.

Figure 1 schematically shows an injector according to an
embodiment, and

25

Figure 2 schematically shows a section of the injector ac-
cording to Figure 1.

Figure 1 schematically shows an injector for injecting fluid.
30 Particularly, the injector is designed for injecting fuel into
a cylinder of an internal combustion engine of, for example, a
vehicle and particularly an automobile. The fluid injector has
a longitudinal axis L and further comprises a housing 1 and valve

body 4. The valve body 4 is coupled with the housing 1 and has a recess 5 in which a valve needle 6 is arranged axially movable.

The valve needle 6 is of the hollow needle type and comprises a
5 closing element at its downstream end arranged for closing the injector in its closed position inhibiting a fluid flow and for allowing the fluid flow otherwise in an open position. In the closing position of the fluid injector in which the fluid flow is inhibited, the valve needle 6, in particular the closing
10 element, sealingly rests on a seat and prevents in this way the fluid flow through at least one injector nozzle. The injector nozzle may, for example, be an injector hole; it may, however, also be of some other type suitable for dosing fluid. The seat may be made as one part with the valve body 4 or may also be made
15 as a separate part. A fluid injection is permitted if the valve needle 6 is in further positions.

The injector further comprises a lifting device with an actuator
8 (Figure 2) for moving the valve needle 6 in its axial direction
20 along the axis L for opening and/or closing the injector. The actuator is preferably a solenoid actuator. The actuator may alternatively be a piezo-actuator.

The housing 1 and an armature 3 form a magnetic circuit. The
25 magnetic circuit guides a magnetic flux of a magnetic field being generated by the solenoid actuator 8.

The solenoid actuator 8 comprises at least one coil. The coil is preferable overmolded. The solenoid actuator may comprise more
30 than one coil.

The actuator 8 is arranged to interact with the armature 3. The armature 3 cooperates with the valve needle 6 such that at least part of the lift generated by the actuator 8 with respect to the

armature 3 is transferred to the valve needle 6, moving the valve needle and the closing element in its open position in which fluid injection is permitted. The armature 3 and the valve needle 6 can move relatively to each other. A needle closing force is provided
5 by a calibration spring 17 (Figure 2) that applies a force to the valve needle 6 in the closing direction.

Figure 2 shows a portion of the injector according to the embodiment of Figure 1 in more detail.

10

The injector comprises a needle retainer 2 that is fixed to the valve needle 6. The needle retainer 2 is directly coupled with the valve needle 6. The needle retainer 2 is directly connected to the valve needle 6. The needle retainer 2 comprises a
15 cross-section with the form of an L. The needle retainer 2 comprises a portion which is elongated in the direction of the L-axis and is at least partly in contact with the valve needle 6. The portion of the needle retainer 2 is fixed to the valve needle 6 such that the valve needle 6 and the needle retainer 2
20 cannot move relative to each other. In particular, the needle retainer 2 is welded with the portion to the valve needle 6 by a welded connection 10.

The needle retainer 2 comprises a second portion that is elongated
25 transverse to the L-axis. The two portions form the L-shaped cross-section of the needle retainer 2.

The injector further comprises an armature holder 7 that is fixed to the armature 3. The armature holder 7 is directly coupled with the armature 3. The armature holder 7 is connected to the armature
30 3. The armature holder 7 comprises a cross-section in form of an L. The armature holder 7 comprises a portion that is elongated in the direction of the L-axis. The portion of the armature holder 7 is fixed to the armature 3. In particular, the armature holder

7 is fixed to the armature 3 by a welded connection 11. The armature holder 7 and the armature 3 are fixed to each other such that they cannot move relatively to each other.

5 The armature holder 7 comprises a further portion that is elongated transverse to the L-axis. The two portions of the armature holder 7 form the L-shaped cross-section of the armature holder 7.

10 The armature holder 7 and the needle retainer 2 are arranged inside the valve body 4 such that the respective portions that are directed transverse to the L-axis comprise a common contact area 15 at least during the opening phase of the injector. During the opening phase of the injector, the valve needle 6 moves in
15 a direction 16 along the L-axis and thus, the closing element moves away from the seat.

The movement of the valve needle 6 in the direction 16 is forced by the movement of the armature 3 in the direction 16. The armature
20 holder 7 moves along with the armature 3 in the direction 16 due to the fixed coupling of the armature holder 7 with the armature 3. A force directed in direction 16 is transmitted from the armature holder 7 to the needle retainer 2 via the contact area 15. At least during the movement of the armature in the direction
25 16, the needle retainer 2 is pushed by the armature holder 7 in the direction 16. Due to the fixed coupling of the needle retainer 2 with the valve needle 6, the valve needle 6 is moved in the direction 16 by the movement of the needle retainer 2. Such, a movement of the armature 3 causes a movement of the valve needle
30 6 via the armature holder 7 and the needle retainer 2.

The coupling of the armature 3, in particular the armature holder 7, with the needle retainer 2 is on the side of the armature 3

that is directed towards the closing element of the valve needle 6.

When the movement of the armature 3 in the direction 16 stops in the maximum open position at the maximum shift of the armature 3 in the direction 16, the valve needle 6 has very limited possibilities to move further in the direction 16 because the needle retainer 2 abuts the armature 3. Thus, the movement of the valve needle 6 in the direction 16 is stopped. This movement is further damped by springs 9 that are arranged between the needle retainer 2 and the armature 3. According to aspects, the spring 9 is a wave spring. According to further embodiments, the spring 9 is an elastic rubber. The spring 9 damps an uncontrolled movement or bouncing of the valve needle 6 when the armature 3 stops.

During the closing phase, the valve needle 6 is moved in a direction opposite the direction 16 along the L-axis. Therefore, the spring 17 applies a force on a needle guide 13 that is fixed to the valve needle 6. The needle guide 13 is fixed to the valve needle 6 by a welded connection 12. The needle guide 13 is arranged at the valve needle 6 on a side of the armature that is opposite the side on which the needle retainer 2 and the armature holder 7 are arranged.

The closing force is transmitted to the valve needle via the needle guide 13. Between the needle guide 13 and the armature 3 is a free space 14. Therefore, the armature 3 and the needle guide 13 have no common contact area. In particular, the armature 3 and the needle guide 13 have no contact during the whole closing phase and opening phase of the injector.

During the closing phase, the needle retainer 2 and the armature holder 7 can decouple. The armature holder 7 gets out of contact

with the needle retainer 2 at least during a part of the closing phase. During the closing phase, the overshoot is also limited because the movement of the valve needle 6 is restricted by the movement of the needle retainer 2 that can only move between the armature 3 and the armature holder 7 along the L-axis.

This allows setting up the maximum possible overshoot of the armature 3 and the valve needle 6 and better controlling the injector behavior under both opening and closing operating conditions. Moreover the proposed design allows the larger contact area 15 between the armature holder 7 and the needle retainer 2 and thus, the wearing between the two components is reduced and the lift value maintained, in particular for the entire injector lifetime, within an acceptable range of variation. Further, there is no need of protective coating in the contact area 15 due to the large available area 15 and due to the reduced the specific contact pressure at the contact area 15. Furthermore, the overshoot during the opening phase and the closing phase is limited and thus allows a better injector dynamic control. The armature 3 is decoupled from the valve needle 6 in a way that the needle retainer 2 and the armature holder 7 together allow the relative movement of the armature 3 with respect to the valve needle 6 and the same elements (the needle retainer 2 and the armature holder 7) are responsible for limiting the armature 3 overshoot and valve needle 6 overshoot.

Claims

1. An injector for injecting fluid, comprising
- a valve needle (6), being axially moveable with respect to a valve body (4) and being operable to prevent a fluid injection in a closing position and to permit the fluid injection in an open position,
 - an armature (3) for moving the valve needle (6) in a first direction (16) from the closing position towards the open position,
 - a needle retainer (2) that is fixed to the valve needle (6),
 - an armature holder (7) that is fixed to the armature (3),
 - the needle retainer (2) and the armature holder (2) are releasably coupleable such that when the armature (3) moves in the first direction (16) the needle (6) is moved in the first direction (16) by the movement of the armature holder (7) and the needle retainer (2).
2. An injector according to claim 1, wherein the armature holder (7) is realized with a cross section in an L-form.
3. An injector according to one of claims 1 or 2, comprising a welded connection (11) between the armature holder (7) and the armature (3) to fix the armature holder (7) to the armature (3).
4. An injector according to one of claims 1 to 3, wherein the needle retainer (2) is realized with a cross section in an L-form.
5. An injector according to one of claims 1 to 4, comprising a welded connection (10) between the needle retainer (2) and the valve needle (6) to fix the needle retainer (2) to the valve needle (6).

6. An injector according to one of claims 1 to 5, wherein the armature holder (7) and the needle retainer (2) are formed such that the armature holder (7) and the needle retainer (2) comprise a common contact area (15).

5

7. An injector according to one of claims 1 to 6, comprising a spring (9) between the needle retainer (2) and the armature (3).

8. An injector according to one of claims 1 to 7, comprising a
10 needle guide (13) that is fixed to the needle (6) such that a free space (14) is arranged between the needle guide (13) and the armature (3) during a movement of the armature (3) in the first direction (16).

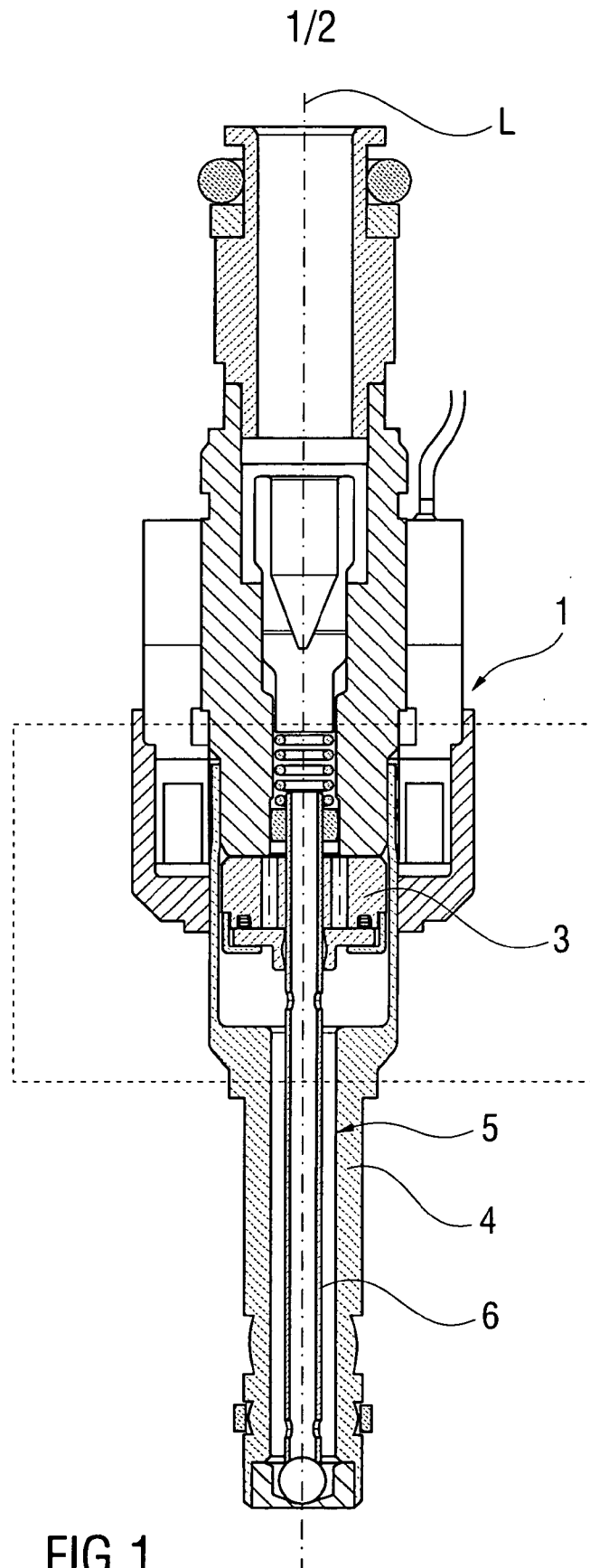

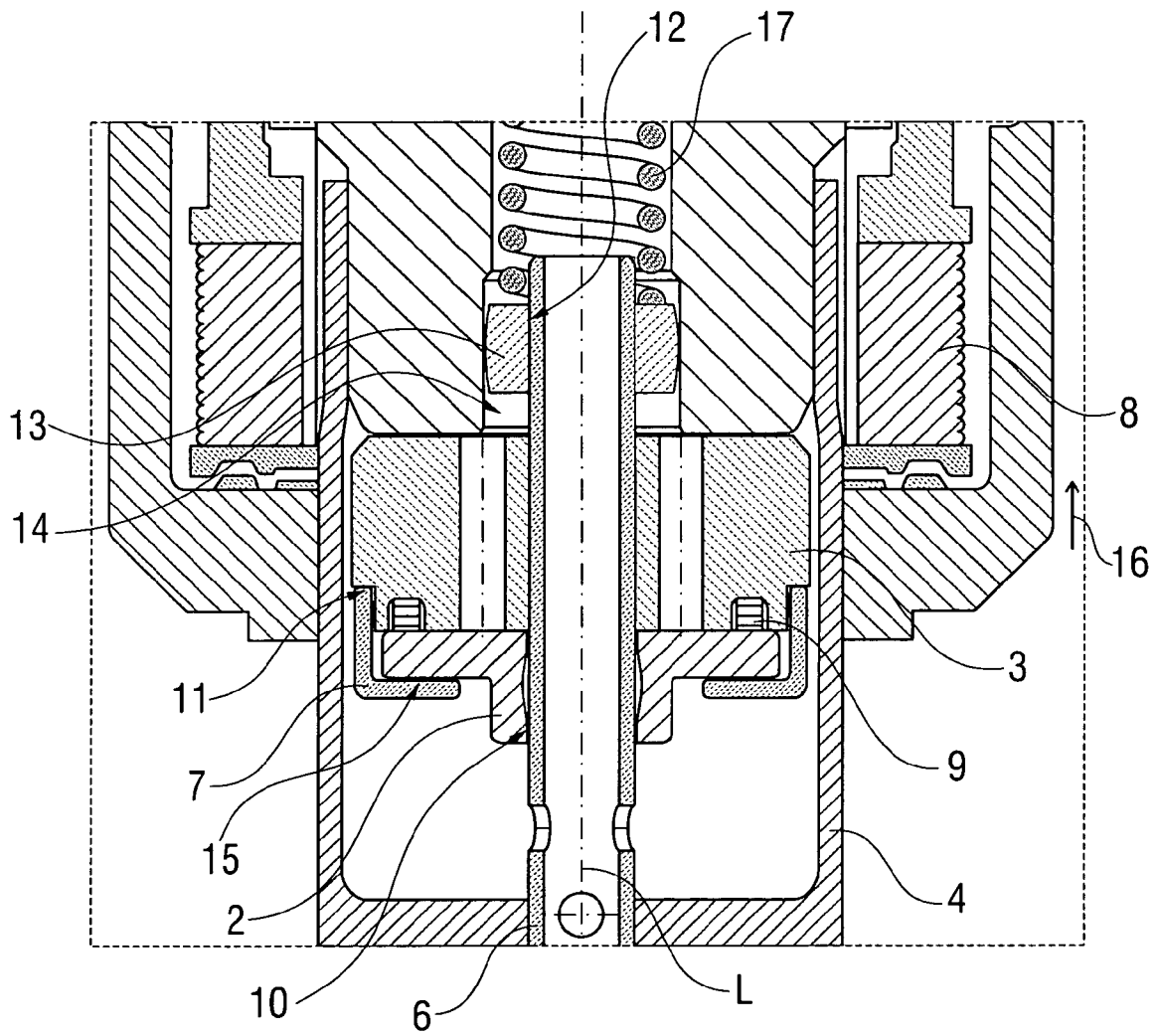

INTERNATIONAL SEARCH REPORT

International application No
PCT/EP2012/059616

A. CLASSIFICATION OF SUBJECT MATTER INV. F02M51/06 ADD. F02M63/00		
According to International Patent Classification (IPC) or to both national classification and IPC		
B. FIELDS SEARCHED		
Minimum documentation searched (classification system followed by classification symbols) F02M		
Documentation searched other than minimum documentation to the extent that such documents are included in the fields searched		
Electronic data base consulted during the international search (name of data base and, where practicable, search terms used) EPO-Internal		
C. DOCUMENTS CONSIDERED TO BE RELEVANT		
Category*	Citation of document, with indication, where appropriate, of the relevant passages	Relevant to claim No.
X	EP 1 460 263 A1 (SIEMENS AG [DE] CONTINENTAL AUTOMOTIVE GMBH [DE]) 22 September 2004 (2004-09-22) paragraphs [0019], [0020]; figure 2 abstract	1-3,6-8
X	DE 10 2004 056424 A1 (BOSCH GMBH ROBERT [DE]) 24 May 2006 (2006-05-24) paragraph [0019] - paragraph [0022]; figure 2	1,3-5,8
A	EP 1 550 804 A1 (BOSCH GMBH ROBERT [DE]) 6 July 2005 (2005-07-06) paragraph [0012] - paragraph [0020]; figure 2	1-8
<input type="checkbox"/> Further documents are listed in the continuation of Box C. <input checked="" type="checkbox"/> See patent family annex.		
* Special categories of cited documents :		
"A" document defining the general state of the art which is not considered to be of particular relevance	"T" later document published after the international filing date or priority date and not in conflict with the application but cited to understand the principle or theory underlying the invention	
"E" earlier application or patent but published on or after the international filing date	"X" document of particular relevance; the claimed invention cannot be considered novel or cannot be considered to involve an inventive step when the document is taken alone	
"L" document which may throw doubts on priority claim(s) or which is cited to establish the publication date of another citation or other special reason (as specified)	"Y" document of particular relevance; the claimed invention cannot be considered to involve an inventive step when the document is combined with one or more other such documents, such combination being obvious to a person skilled in the art	
"O" document referring to an oral disclosure, use, exhibition or other means	"&" document member of the same patent family	
"P" document published prior to the international filing date but later than the priority date claimed		
Date of the actual completion of the international search 22 June 2012	Date of mailing of the international search report 28/06/2012	
Name and mailing address of the ISA/ European Patent Office, P.B. 5818 Patentlaan 2 NL - 2280 HV Rijswijk Tel. (+31-70) 340-2040, Fax: (+31-70) 340-3016	Authorized officer Hermens, Sjoerd	

INTERNATIONAL SEARCH REPORT

Information on patent family members

International application No

PCT/EP2012/059616

Patent document cited in search report	Publication date	Patent family member(s)	Publication date
EP 1460263	A1	22-09-2004	NONE

DE 102004056424	A1	24-05-2006	NONE

EP 1550804	A1	06-07-2005	DE 10361761 A1 28-07-2005
			EP 1550804 A1 06-07-2005
			JP 2005195015 A 21-07-2005
