

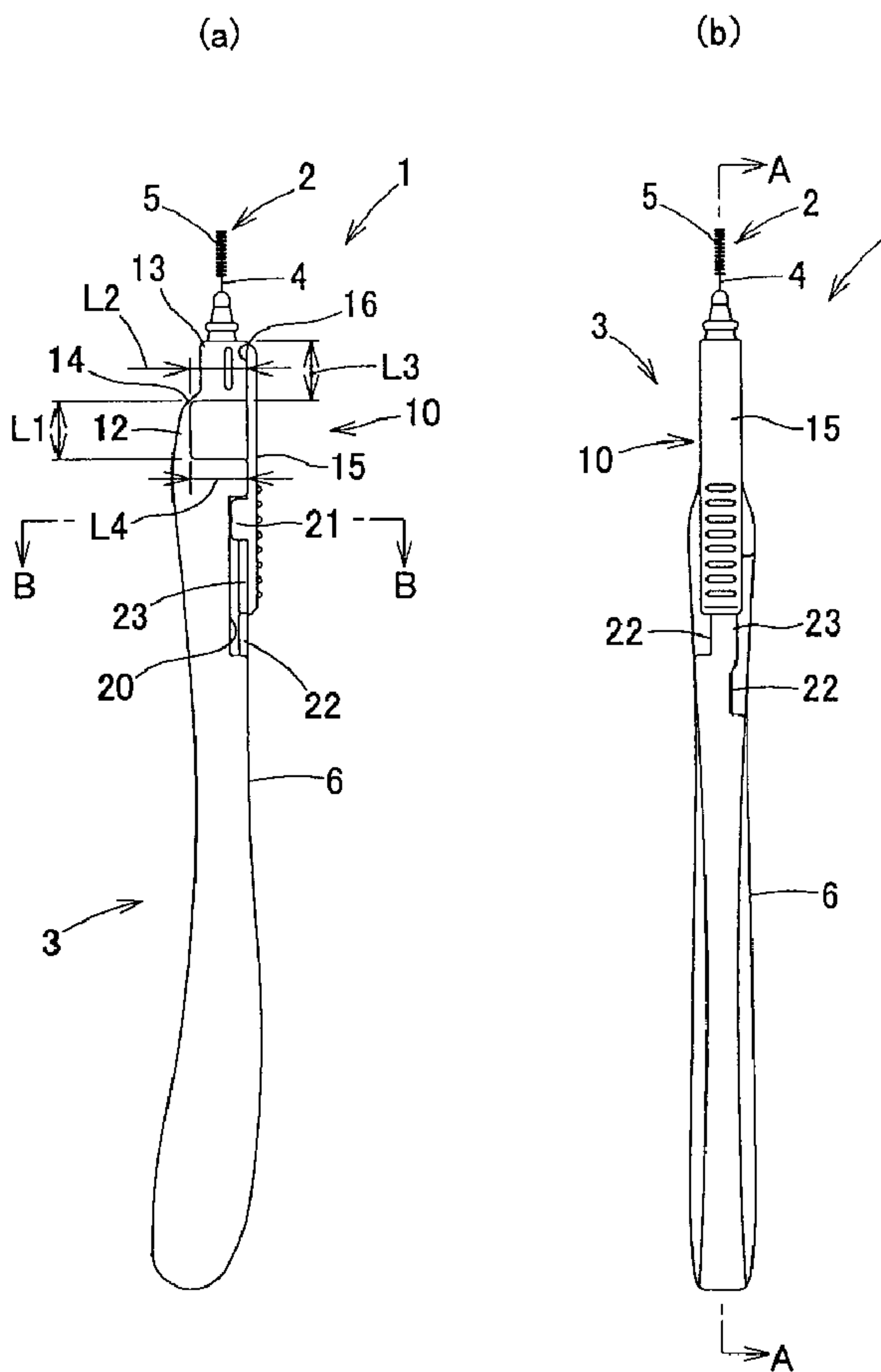

(86) Date de dépôt PCT/PCT Filing Date: 2004/11/11
 (87) Date publication PCT/PCT Publication Date: 2005/05/26
 (45) Date de délivrance/Issue Date: 2012/03/13
 (85) Entrée phase nationale/National Entry: 2006/05/08
 (86) N° demande PCT/PCT Application No.: JP 2004/016727
 (87) N° publication PCT/PCT Publication No.: 2005/046388
 (30) Priorité/Priority: 2003/11/13 (JP2003-383772)

(51) Cl.Int./Int.Cl. *A46B 5/00* (2006.01)
 (72) Inventeurs/Inventors:
 TSURUKAWA, NAOKI, JP;
 TAKANO, HIDEKUNI, JP;
 NAKATSUKA, HIROHISA, JP
 (73) Propriétaire/Owner:
 SUNSTAR INC., JP
 (74) Agent: BORDEN LADNER GERVAIS LLP

(54) Titre : BROSSE INTERDENTAIRE
 (54) Title: INTERDENTAL BRUSH



(57) Abrégé/Abstract:

The present invention provides an interdental brush and a cap, said brush having a good handling property and a low manufacturing cost, said brush being stored with the cap on while adjusting the brush body at any angle. The handle member (3)

(57) **Abrégé(suite)/Abstract(continued):**

supporting the brush body (2) includes a handle body (6), an arm (12) extending from one end of the handle body (6), a brush support (13) that holds a base of the brush body (2), a first hinge (14) that connects the tip of the arm (12) and one end of the brush support (13) in a freely rotating manner, an operating portion (15) provided slidably at the other end of the handle member (3), and a second hinge (16) that connects the tip of the operating portion (15) and the other end of the brush support (13) in a freely rotating manner.

ABSTRACT

The present invention provides an interdental brush and a cap, said brush having a good handling property and a low manufacturing cost, said brush being stored with the cap on while adjusting the brush body at any angle. The handle member (3) supporting the brush body (2) includes a handle body (6), an arm (12) extending from one end of the handle body (6), a brush support (13) that holds a base of the brush body (2), a first hinge (14) that connects the tip of the arm (12) and one end of the brush support (13) in a freely rotating manner, an operating portion (15) provided slidably at the other end of the handle member (3), and a second hinge (16) that connects the tip of the operating portion (15) and the other end of the brush support (13) in a freely rotating manner.

INTERDENTAL BRUSHTechnical Field

This invention relates to an adjustable interdental brush with a cap that can be attached and detached regardless of the brush body angle.

Background

The interdental brushes generally known and used consist of a handle and a brush body formed of a thin metal wire strand folded and twisted wherein a filament is captured between the wire. The brushes are generally cylindrical or cone-shaped and the handle is generally synthetic and often cylindrical of appropriate size to hold in the hand. A wire base of the brush body is often fixed onto the handle using methods such as insert molding and other physical joining methods including thermal fusion by high frequent and ultrasonic waves to integrate the brush body with the handle.

The problem with such conventional interdental brushes is that the base was often bent to fit into the gap between teeth to insure the best angle between the handle member and the brush. Repeating this procedure will damage the wire quite easily in a fairly short time period.

As a proposed solution, some interdental brushes have a handle, and a brush support member to fix and hold the brush body, with the tip of the handle branched in two on which the brush support member is pivotally supported in a freely rotating manner. (See Kokai Disclosure No. 9-121942 (Patent Document 1).) However, such interdental brushes have the problem of increased manufacturing costs due to the increased number of parts necessary to make the brush support member.

Another type of interdental brush has been proposed in which the handle is made of two sub-handles, right and left sub-handles symmetrically centered on a common axis to form one handle, with the tip of both sub-handles fixed via five rings with a wire support. (See Kokai Application No. 8-508179 (Patent Document 2).)

The interdental brush shown in Patent Document 2 adjusts the angle of the brush body against the handle by sliding the right and left sub-handles in the direction of the handle by which operation the cleaning action is enhanced. By forming the handle member so that these two sub-handles can open at an angle of 180° , the handle can be formed in one process whereby the number of parts and costs incurred are reduced.

[Patent Document 1] Kokai Disclosure No. 9-121942

[Patent Document 2] Kokai Application No. 8-508179

DISCLOSURE OF THE INVENTIONSubject to be solved by the invention

However, the problem with the interdental brush shown in Patent Document 2 lies in the fact that the handle member must be cast with the two sub-handles in the open position. This requires the surface area of the mold to be more than twice as large as that required for a conventional handle, negatively impacting productivity of manufacture. Moreover, to make a handle a convenient length to hold, a large mold is required, resulting again in increased cost. In addition, as this toothbrush adjusts the brush body by sliding the sub-handles, it is not easy to use due to the potential risk of accidentally sliding the sub-handle while using the interdental brush. As a result, interdental brushes made this way are generally small in size and hard to use.

According to one aspect of the present invention there is provided an interdental brush comprising: a handle; a brush body; a brush support for holding the brush body; an arm connected at one end to one side of the handle and hingedly connected at the other end to a lower portion of a first side of the brush support; and an operating portion hingedly connected to an upper portion of a second side of

the brush support and slidably connected to the handle so as to be movable along a length direction of the handle for rotating the brush support relative to the handle in a range of about 90 degrees.

According to a further aspect of the present invention there is provided an interdental brush having a brush body and a handle member, the handle member comprising: a handle having a first side and a second side; an arm extending from the first side of the handle along a length direction of the handle and having a tip; a brush support that holds the brush body and having an upper end, a lower end, a first side and a second side; a first hinge that connects the tip of the arm and the first side of the brush support at the lower end of the brush support in a freely rotating manner; an operating portion situated in a position-changeable manner at the second side of the handle and slidable along the length direction of a part of the handle, the operating portion having a tip; and a second hinge that connects the tip of the operating portion and the second side of the brush support at the upper end of the brush support in a freely rotating manner, wherein changing a position in a length direction of the operating portion against the handle enables a user to rotate the brush body relative to the handle.

Here, an adjustable brush, which is easy-to-handle, cost-competitive and has a cap attachable to the brush regardless of its angle is disclosed.

The interdental brush which meets the above requirements is one having a brush body and a handle member. The handle member consists of a handle, an arm extending from one end of the handle along the length of the handle, a brush support that holds the base of the brush body, a first hinge that connects the tip of the arm and one end of the brush support in a freely rotating manner, an operating portion situated in a position-changeable manner at the other end of the handle member and slidable along the length of the handle, and a second hinge that connects the tip of the operating portion and the other side of the brush support in a freely rotating manner. Changing a position of the operating portion along the handle's length enables the user to rotate the brush body about the hinge.

The interdental brush may have a cap comprising a cap body covering the entire brush body, a cap base that is removably attachable to the brush support, and an opening formed by the cap base and cap body to cover the brush and the brush support. The cap preferably has an opening extending the length of the cap body and cap base to cover the entire brush body and brush support from the back.

When the operating portion of the interdental brush has a sliding portion at the other end of the handle member that moves along the length of the handle, and when the above-mentioned position changing is done by sliding, moving the slide gives an optimum angle for the brush body depending on the gap between the teeth. This movement can be done easily and in a stable manner while holding the handle, with or without attaching the extension pipe. Thus, the operational performance of the interdental brush can be improved by fitting its brush angle to the gap between the teeth.

Adding the position support means between the handle and the operating portion to keep the brush support at first and second positions centered on the first hinge can hold the brush at these switch-over positions, giving stability of the brush while cleaning, and hence, the operation of the brush can be enhanced by adjusting the brush angle to the optimum position.

Connecting the tip of the arm to one end of the brush support via the first hinge and the tip of the operating portion and the other end of the brush support via the second hinge can hold the brush support at the alternative two positions centered on the first hinge, and the position of the brush body is stabilized while in operation and hence the operational performance of the brush is enhanced. In

other words, for example, depicting the brush support as a square will locate both hinges at the ends of the diagonal line of the brush support, giving a distance between both hinges larger than that for the end-to-end length of the brush base. Thus, sliding the operating portion will generate a large slide friction due to the sideways movement, resulting in the operating portion being easy to hold at either of the two positions, and the brush support to be held in the two switch-over positions.

The cap for the interdental brush comprises a cap body covering the entire brush and a detachable cap base that fit onto the brush body and brush support from the back. Thus, the cap fits quite easily and safely onto the brush body and brush support of the brush using the opening in the cap body and cap base. This is a benefit for elderly people with poor eyesight. In addition, because the cap is fitted to the brush support, the brush body angle can be adjusted easily and sanitarily while the cap is on it without using bare hands. Because the cap can be fitted to the toothbrush while holding the brush body at any angle, the brush can be stored while the brush body is disposed at any angle relative to the handle.

References to directions (e.g., left/right, up/down) refer to the orientation within the various figures shown

herein and are for convenience only. They should not be used to limit the invention.

Effect of the invention

The productivity of manufacture of this interdental brush is increased and its cost reduced, as the handle, arm, brush support, operating portion, and hinges are integral parts of the handle member and can be molded in one process using synthetic resin. In addition, the handle length can be adjusted, making it convenient to hold by changing its size and by adding an extension pipe to form the handle of the brush. As it does not require opening the handle members to 180 degrees, unlike the brush shown in Patent Document 2, it does not require a large mold and hence, an easy-to-handle brush can be manufactured quite cost-effectively. Moreover, by adjusting the position of the operating portion along the length of the handle, an optimized angle of the brush body can be obtained to fit in the gaps between teeth and cleaning performance can be improved. Also, operation of the interdental brush can be improved, as it allows to hold stably the handle or the extension pipe connected thereto by hand.

The cap for this interdental brush can fit the brush body and brush support with the cap body and cap base using the opening from the side, so that the cap can be attached

to the brush for storage, whatever the angle of the brush body. Hence, the operation of attaching and detaching the cap from the toothbrush as well as the ease of storage with the cap attached can be enhanced. As the cap is held at the brush support, the brush angle can be adjusted with its cap on without touching the brush with bare hands, and the sanitary condition of the brush is maintained.

Brief Description of Drawings

[Fig. 1] (a) is a front elevational view of the interdental brush; Fig. 1(b) is a right side elevational view of the interdental brush of Fig. 1(a).

[Fig. 2] (a) is a cross-sectional view through line A-A of Fig. 1 (b); Fig. 2(b) is a cross-sectional view through line B-B of Fig. 1(a).

[Fig. 3] (a) is a partial perspective view of the tiltable support; Fig. 3(b) is a partial perspective view of the operating portion.

[Fig. 4] is a front elevational view of the interdental brush at the second position.

[Fig 5] (a) is a partial front cross-sectional view of a second embodiment of the interdental brush; Fig. 5(b) is a right side elevational view of the interdental brush of Figure 5(a).

[Fig. 6] (a) is a front elevational view of a third embodiment of the interdental brush at the first position; Fig. 6(b) is a front elevational view of the interdental brush of Fig. 6(a) at the second position.

[Fig. 7] (a) is a partial front cross-sectional view of the cap and the interdental brush at the first position; Fig. 7(b) is a cross-sectional view through line C-C of Fig. 7(a); Fig. 7(c) is a right elevational view of the cap; and Fig. 7(d) is a partial front cross-sectional view of the cap and the interdental brush at the second position.

Description of signs

- 1 Interdental brush
- 2 Brush body
- 3 Handle member
- 4 Wire
- 5 Brush
- 6 Handle body
- 10 Tilttable support portion
- 12 Arm
- 13 Brush support
- 14 First hinge
- 15 Operating portion
- 16 Second hinge
- 20 Slide guide

- 21 Stop
- 22 Cutout
- 23 Control portion
- 1A Interdental brush
- 3A Handle member
- 6A Handle body
- 15A Operating portion
- 30 Hole
- 31 Guiding plate
- 32 Slide hole
- 33 Engagement portion
- 34 Wider hole
- 1B Interdental brush
- 3B Handle member
- 6B Handle body
- 15B Operating portion
- 35 Recessed portion
- 36 Protrusion
- 50 Cap
- 51 Cap body
- 52 Cap base
- 53 Opening
- 54 Protrusion
- 55 Recessed portion

Best mode for carrying out the invention

As Figure 1 shows, the interdental brush [1] is comprised of the brush body [2] including the brush [5] and the wire [4], and the handle member [3] supporting the brush body.

The brush body [2] shown in Figures 1 and 2 is made of thin wire [4] strands folded and twisted, and filaments captured radially by the wire [4], in a well-known configuration. The profile of the brush [5] can be either cylindrical or conical. It can also be barrel-shaped with the outer diameter of the middle portion of the brush larger than that of the top or the bottom of it. The brush body [2] and handle can be made by a one-shot molding of synthetic resin, including the brush and its core support.

As Figures 1 to 4 show, the handle member [3] comprises a elongated handle [6] of appropriate size to hold in the hand and a tiltable support portion [10] attached to the upper end of the handle [6]. The brush body [2] is connected to the handle [6] in a freely movable manner by way of the tiltable support portion [10]. The handle member [3] is made of synthetic resin having a property capable of withstanding repeated bending of an integrally formed hinge and enough strength to serve as a handle, such as polyethylene, polypropylene or thermoplastic elastomer, and

the handle member [3] is formed by one-shot molding by a method such as injection molding.

As shown in Figures 1(a) and 2(a), the tiltable support portion [10] consists of an arm [12] extending upward from the left end (one side at the tip) of the upper, roughly even surface of the handle [6], a brush support [13] with the bottom (the proximal end) of the wire [4] of the brush body [2] fixed therein, a first hinge [14] connecting the upper end of the arm [12] and left bottom end of the brush support [13] which rotate freely with respect to each other, an operating portion [15] at the right side (other side) of the handle member [3] in a manner that is freely slidable along the length of the handle [6], and a second hinge [16], comprising an integrally formed hinge, that connects the upper end of the operating portion [15] and the right upper end of the main body of the brush support [13] in a freely rotating and movable manner. The position of the brush support [13] is supported in a range of about 90 degrees centered on the first hinge [14] in a freely rotating and movable manner by operating the operating portion [15] upward or downward, between in a first position in Figure 1(a) with the brush body [2] directed upward or downward and in a second position in Figure 4 with the brush body [2] directed left or right direction.

As Figure 1 shows, the L1 length between the proximal end of the arm [12] and the first hinge [14] is almost equal to or slightly longer than the L2 length between the right end of the bottom of the brush support [13] and the first hinge [14]. The L3 length between the bottom of the brush support [13] and the second hinge [16] is almost equal to or slightly longer than the L4 length between the right end of the handle [6] and the arm [12]. In addition, the upper surface of the handle [6] and the right surface of the arm [12] almost form a right angle. The same is true in the case of the angle between the lower surface of the brush support [13] and the right surface of the brush support [13]. When the brush support [13] is in the first position shown in Figure 1(a), the angle between the lower surface of the brush support [13] and the right surface of the arm [12] is almost at a right angle, whereas when the brush support is in the second position shown in Figure 4, the lower surface of the brush support [13] is almost in contact with the right surface of the arm [12] (the lower side in Figure 1) and the bottom surface of the brush support [13] is almost in contact with the upper surface of the handle [6] (the lower right side in Figure 1). In addition, in this second position, the second hinge [16] moves closer to the right end of the upper surface of the handle [6].

In this embodiment, the lengths and angles described above are for the purpose of enabling the rotation of the brush body [2] between the first and second positions shown in Figures 1(a) and 4 over a range of rotation of approximately 90°. However, the range of rotation of the brush body [2] can be altered by changing these lengths and angles.

In order to enable the operating portion [15] to slide only upward and downward freely along the handle [6], a pair of slide guides [20] is formed extending along the upper handle [6]. A pair of stops [21] are formed on the opposite sides and at the lower end of the operating portion [15] to slidably grip and fit into slide guides [20]. The operating portion [15] is thus slidably fitted to the handle portion [6] with the stops [21] freely movable in the slide guides [20].

The front and the rear stops [21] are not disposed directly opposite each other, but are staggered a distance in an upward and a downward direction with respect to each other as are the front and the rear slide guides [20] in order to accommodate the stops [21] so that the handle member [3] can be molded by a pair of molds. It is possible to locate the stops [21] and slide guides [20] symmetrically in the front and the rear direction with respect to the

handle [6], though this would require slightly different molding configurations.

Cutouts [22] are formed in each of the upper and the lower portion of the slide guides [20], and the operating portion [15] can be fit onto the handle [6] by engaging the front and the rear stops [21] through the cutouts [22] into the slide guides [20] one after another, using the elasticity of the operating portion [15]. The control portion [23] is located between the upper and lower cutouts [22] which blocks the movement of the operating portion [15] downward by engaging the control portion [23] with the base of the stops [21], when the brush body [2] is at the first position by moving the operating portion [15] upward, and which blocks the movement of the operating portion [15] upward by engaging the control portion [23] with the base of the stops [21], when the brush body [2] is at the second position by moving the operating portion [15] downward. To move the operating portion [15] from the upper position to the lower position, or vice versa, the operating portion [15] should be forced to push upward or downward against the elasticity of the material beyond the control portion [23] to move the stops [21] to upper or lower cutouts [22]. A position maintaining means of the interdental brush [1] is structured by the cutouts [22], control portion [23] and stops [21].

The interdental brush [1] is designed so that moving the operating portion [15] upward will make the brush body [2] and the brush support [13] rotate to the first position as shown in Figure 1 about the first hinge [14], whereas moving the operating portion [15] downward will make the brush body [2] and the brush support [13] rotate to the second position about the first hinge [14]. By rotating the position of the operating portion [15], cleaning can be done by changing the position of the brush body [2] to best suit the gap between the teeth. When the brush body [2] is in the first or second positions, the stops [21] on the operating portion [15] will engage the control portion [23] and cleaning can be done by stabilizing the brush body [2] at the appropriate position. The frictional engagement of the stops and slide guides is such that there is sufficient resistance that the angle of the brush body does not readily change during use, but the angle can be readily changed by the user. The ridges shown on operating portion 15 provide a tactile way for the user to overcome the frictional engagement and change the angle.

In the preferred embodiment, an interdental brush [1] with a handle [6] of appropriate length for ease of handling is provided. However, other battery-driven interdental brushes or other handles can be used by adding a short detachable extension pipe, and the brush can substitute for

any other battery-driven interdental brush. Here, the brush body [2] is permanently fixed to the handle member [3] by embedding a wire [4] in the brush support [13]. However, it is also applicable to a system in which the brush body [2] can be replaced. It's also possible to engage a brush integrally formed with a brush body and a brush support to a handle member by using stops means.

In another embodiment, as shown in Figure 5, the interdental brush [1A] has a handle member [3A] with an elongated hole [30] extending through the front and rear sides of the body at the upper right of the handle [6A]. A guiding plate [31] is attached at the right of the hole [30]. A narrow slide hole [32] in the middle of the guiding plate [31] is in communication with hole 30 to accept the engagement portion [33] that protrudes from the free end of the operating portion [15A]. Wider holes [34] are located at the upper and lower ends of the slide hole [32]. In this embodiment, when the engagement portion [33] is fitted into the upper large hole [34], the brush body [2] together with the brush support [13] is kept in the first position. When the engagement portion [33] is engaged in the lower large hole [34], the brush body [2] together with the brush support [13] is kept at the second position. Moving the operating portion [15A] upward and downward will move the engagement portion [33] through the narrowed portion of the

slide hole [32] to move to the upper or lower large holes [34] to keep the brush body [2] at the first or second positions changeably.

In another embodiment, the handle member [3B] of the interdental brush [1B] as shown in Figure 6, has more than one recessed portion [35] in the shape of, for example, a dovetail groove. The recesses [35] are located at intervals along the upper right surface of the handle [6B] to receive the protrusion [36] on recessed portion [35]. When the protrusion [36] is engaged in one of the recesses [35], the brush [2] is held in the first or second position. To rotate the brush [2], the protrusion is disengaged from the recess and the operating portion [15B] is moved so that the protrusion [36] is engaged with the other recess [35]. Any number of recesses [35] can be formed in the handle [6B] to hold the brush [2] in a plurality of different positions. In this embodiment, the brush body [2] is structured in a position-changeable manner between the first and the second position by moving the operating portions [15], [15A] and [15B] upward or downward. But it's also possible to make a structure capable of being changed in a plurality of positions, more than one.

The cap [50] can be used for interdental brush [1], [1A] and [1B], as well as other types of interdental brushes. As Figure 7 (a) shows, the cap [50] consists of a

cap body [51] that covers the entire brush body [2] and a cap base [52] that engages the brush support [13]. An opening is provided at the right side of the cap body [51] so that the cap [50] may be placed over the brush [2] and brush support [13].

As Figures 7 (b) and (c) show, long thin protrusions [54] are formed on the front and rear opposite sides of inner surface of the cap base [52]. The front and rear sides of the brush support [13] are provided with recessed portions [55] to receive the protrusions [54]. The cap [50] is fitted to the brush support [13] by engaging the protrusions [54] with the recessed portions [55] so that the cap may be attached and detached from the brush support [13]. The cap [50] thus may cover the entire brush body [2] and the brush support [13]. Alternatively, a hook system can be used to engage the cap base [52] to the brush support [13].

The cap [50] can be fitted to the interdental brush [1] while holding the brush body [2] and the brush support [13] in the first position as shown in Figure 7 (a) or the second position as shown in Figure 7 (d) and the interdental brush [1] can be stored in these respective positions with the cap [50] on. Therefore, the ease of fitting the cap [50] onto the interdental brush [1] and the ease of storing the interdental brush [1] with the cap [50] on is significantly

enhanced. In addition, as the cap base [52] engages the brush support [13] to fix the cap [50] to the brush support [13], the angle of the brush body [2] is adjustable while the cap [50] is on, to maintain sanitary conditions without touching the brush body [2].

The embodiments described above and illustrated in the figures are presented by way of examples only and not intended as a limitation upon the concepts and principles of the present invention. As such, it will be appreciated by one having ordinary skill in the art that various changes in the elements and their configuration and arrangement are possible without departing from the spirit and scope of the present invention

CLAIMS:

1. An interdental brush comprising:
 - a handle;
 - a brush body;
 - a brush support for holding the brush body;
 - an arm connected at one end to one side of the handle and hingedly connected at the other end to a lower portion of a first side of the brush support; and
 - an operating portion hingedly connected to an upper portion of a second side of the brush support and slidably connected to the handle so as to be movable along a length direction of the handle for rotating the brush support relative to the handle in a range of about 90 degrees.

2. The interdental brush according to claim 1 including a mechanism cooperating with the operating portion for moving the brush support between a first and second position and holding the brush support at either position, said mechanism being provided on the handle.

3. The interdental brush according to claim 1 or 2
 - wherein the friction between the operating portion and the handle is sufficiently low to permit movement of the operating portion relative to the handle, but sufficiently high to prevent unwanted movement of the brush body during use of the interdental brush.

4. An interdental brush according to any one of claims 1 to 3 including a removable cap comprising a cap body which covers the brush body and a cap base which connects to the brush support, and
 - the cap body and the cap base having an opening which allows capping the brush body and brush support.

5. The interdental brush according to claim 4
wherein the opening in the cap allows capping the brush body and brush support from a side thereof.
6. The interdental brush according to claim 4 or 5
wherein the cap can be attached to the interdental brush regardless of the angle of the brush.
7. An interdental brush having a brush body and a handle member, the handle member comprising:
a handle having a first side and a second side;
an arm extending from the first side of the handle along a length direction of the handle and having a tip;
a brush support that holds the brush body and having an upper end, a lower end, a first side and a second side;
a first hinge that connects the tip of the arm and the first side of the brush support at the lower end of the brush support in a freely rotating manner;
an operating portion situated in a position-changeable manner at the second side of the handle and slidable along the length direction of a part of the handle, the operating portion having a tip; and
a second hinge that connects the tip of the operating portion and the second side of the brush support at the upper end of the brush support in a freely rotating manner,
wherein changing a position in a length direction of the operating portion against the handle enables a user to rotate the brush body relative to the handle.
8. The interdental brush of claim 7,
wherein a pair of slide guides are provided along the length of the handle and the operating portion has at least

one stop which fit into and slide within the slide guides, and

wherein the at least one stop is provided to restrict movement of the operating portion within the guides and the operating portion is situated slidably in a length direction of the handle.

9. The interdental brush according to claim 7

wherein the operating portion and handle have a plurality of cooperating protrusions and recesses that are located at intervals along the length of the handle and that allow the operating portion to be moved to these locations along the length of the handle and thereby to move the brush body through a plurality of positions.

Fig. 2

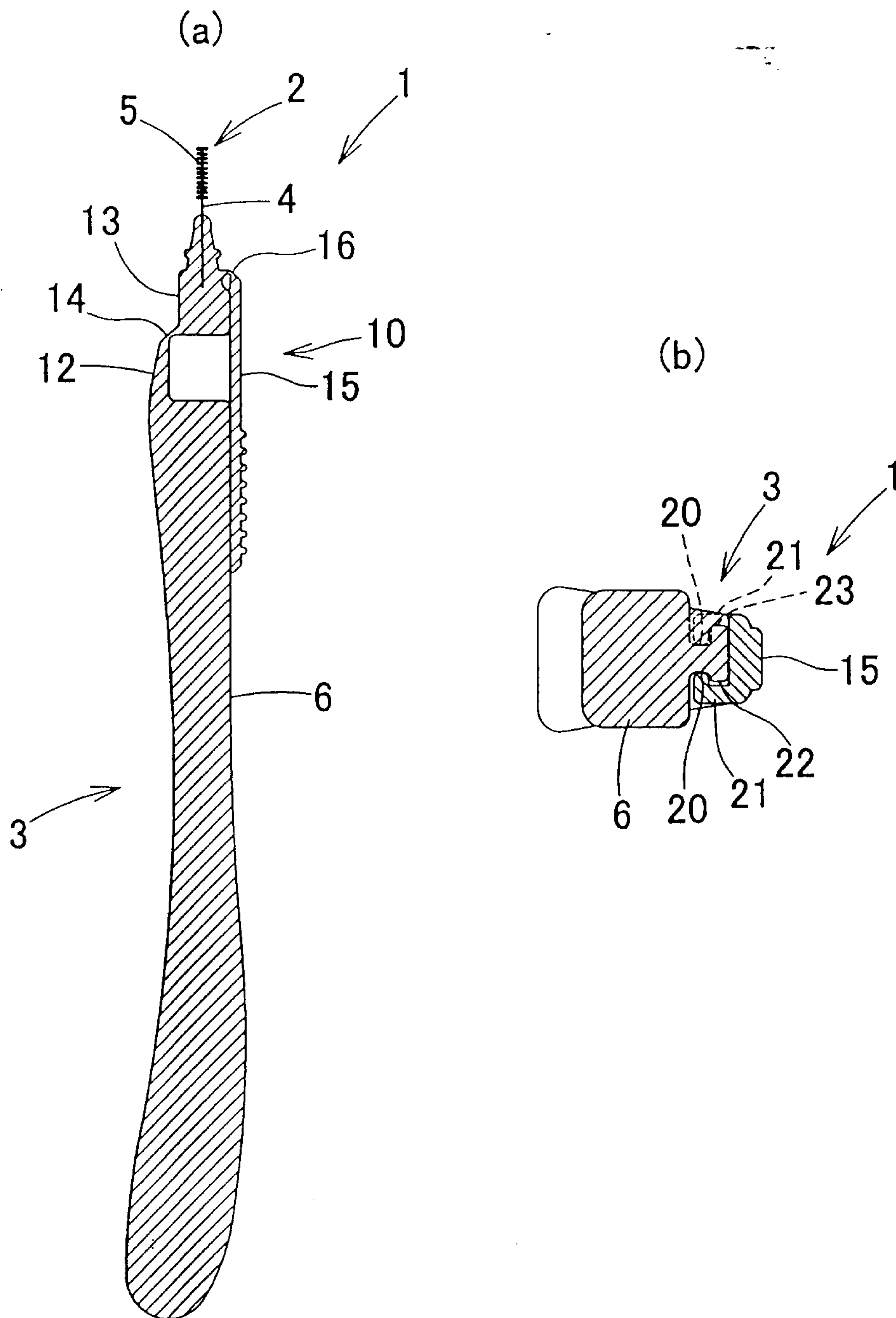
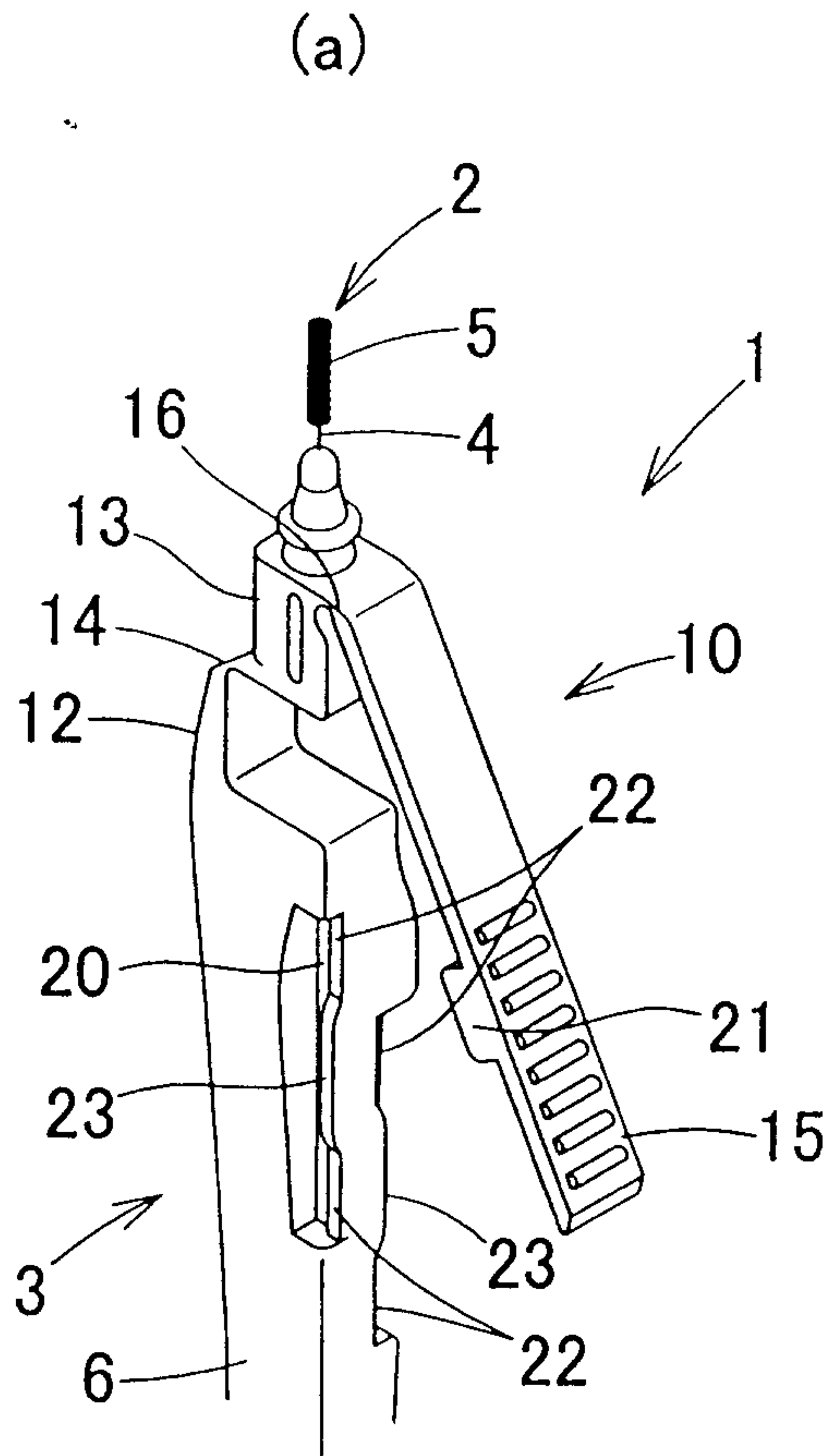

Fig. 3



(b)

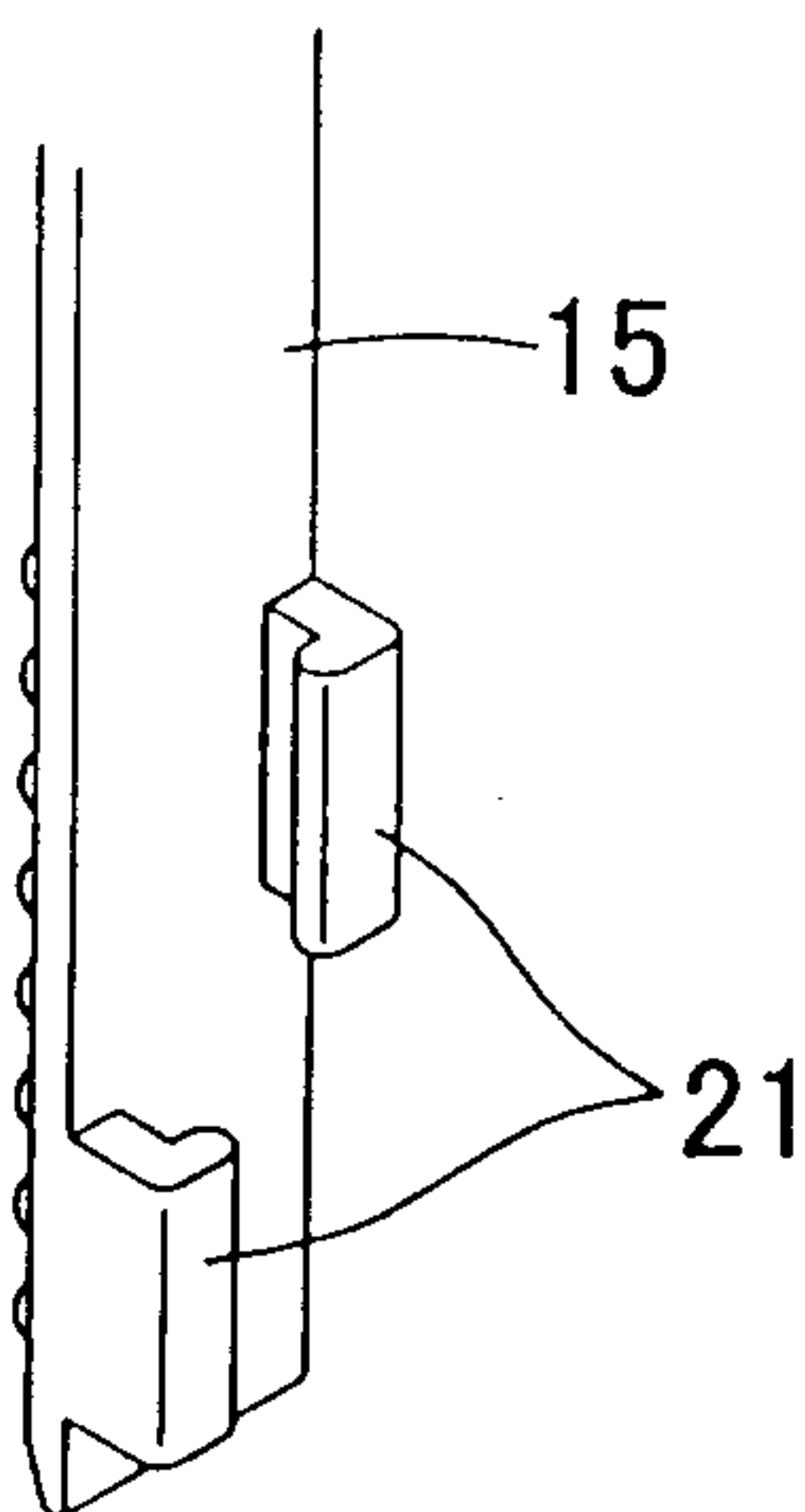

Fig. 4

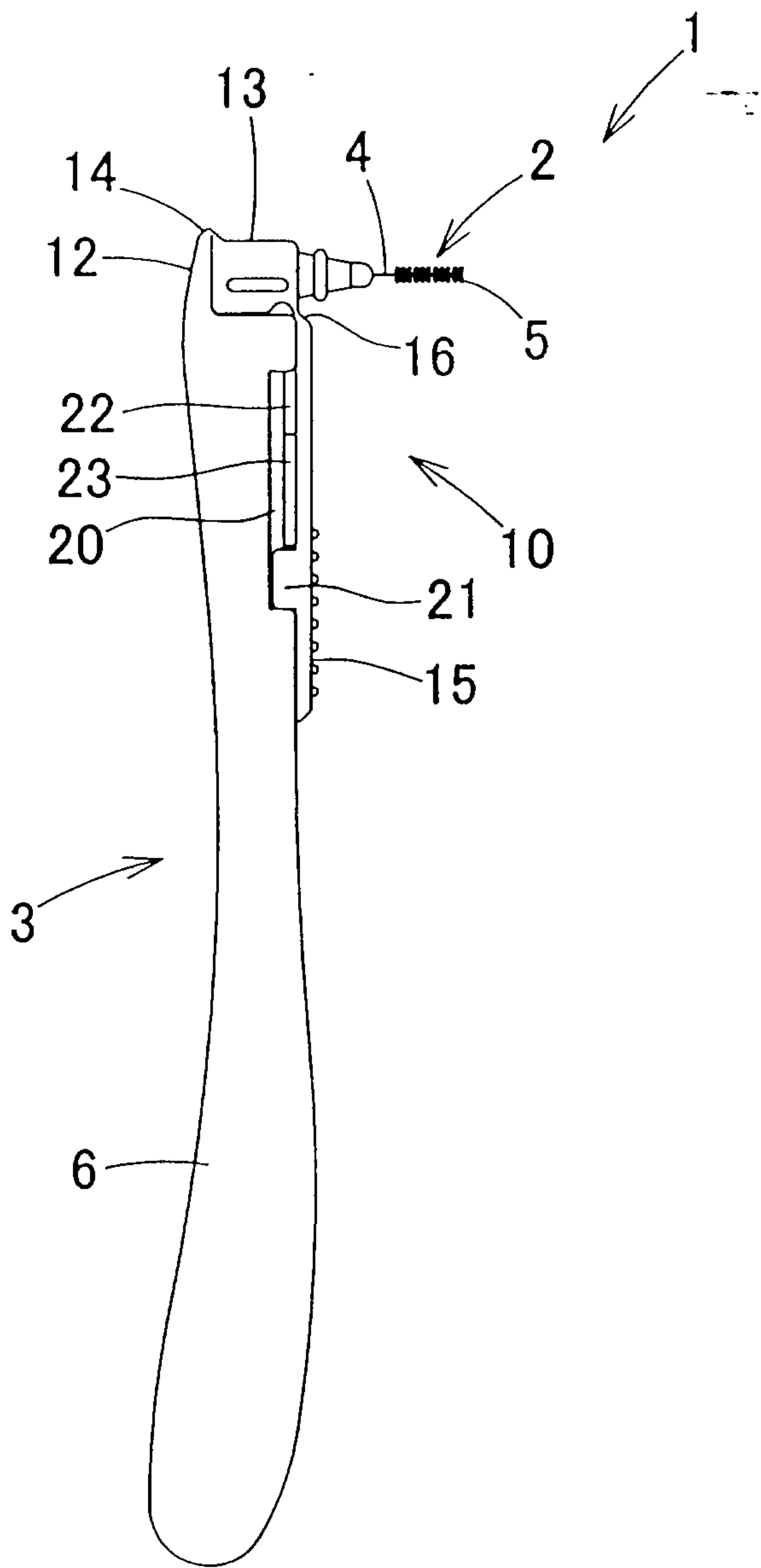

Fig. 5

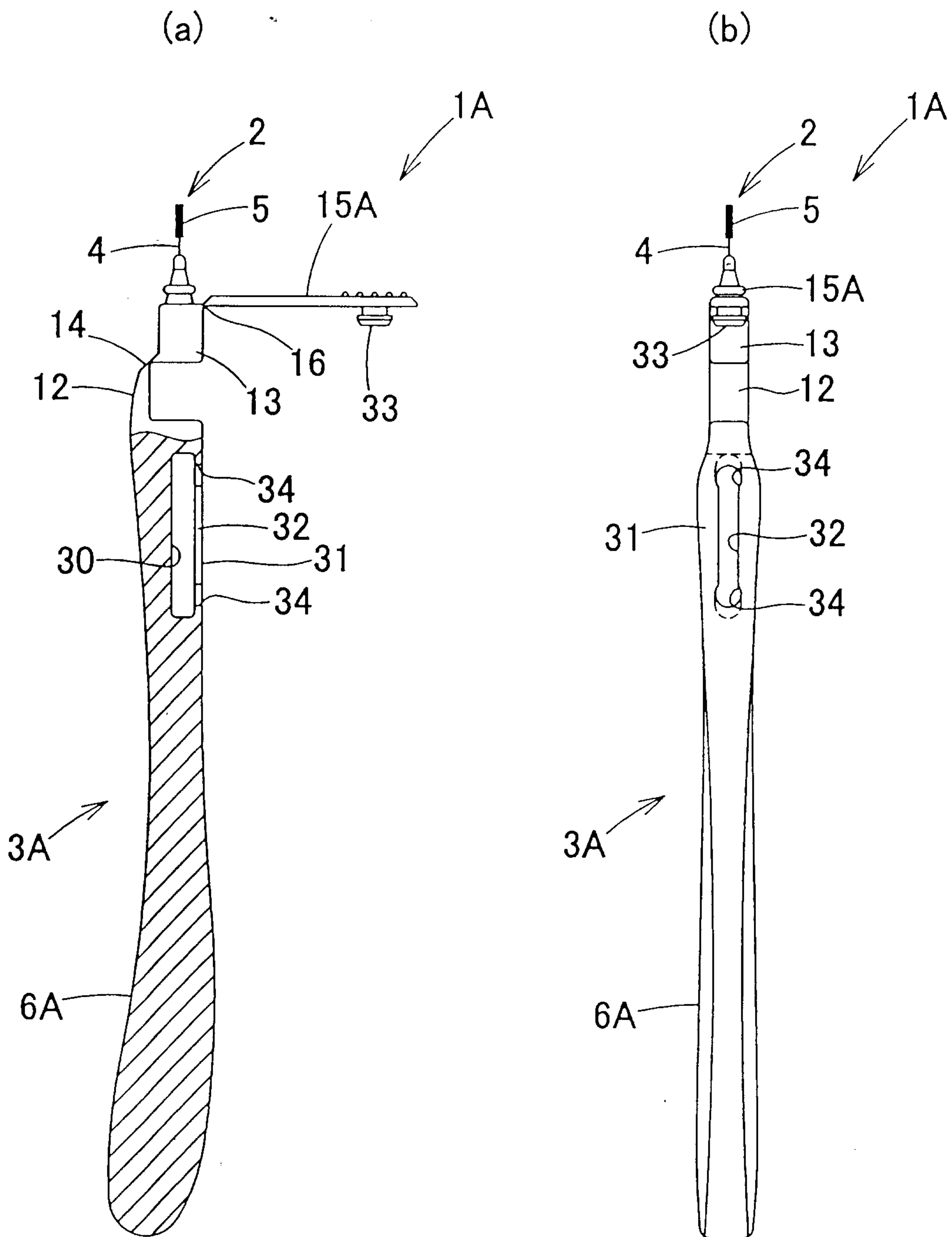

Fig. 6

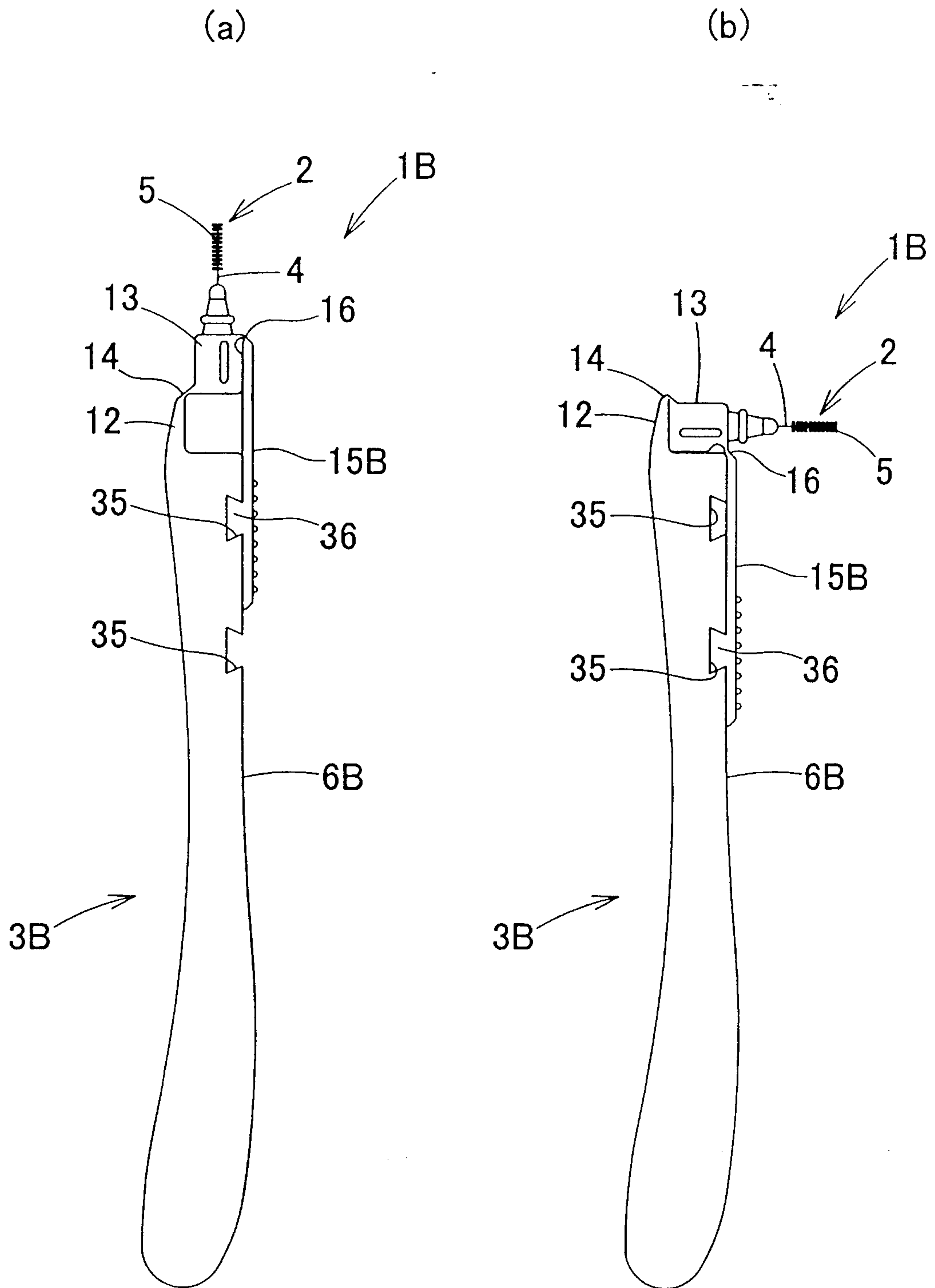

Fig. 7

