

(No Model.)

M. DUESBERG-DELREZ.
APPARATUS FOR SETTING TEETH IN CARD CLOTHING.

No. 526,564.

Patented Sept. 25, 1894.

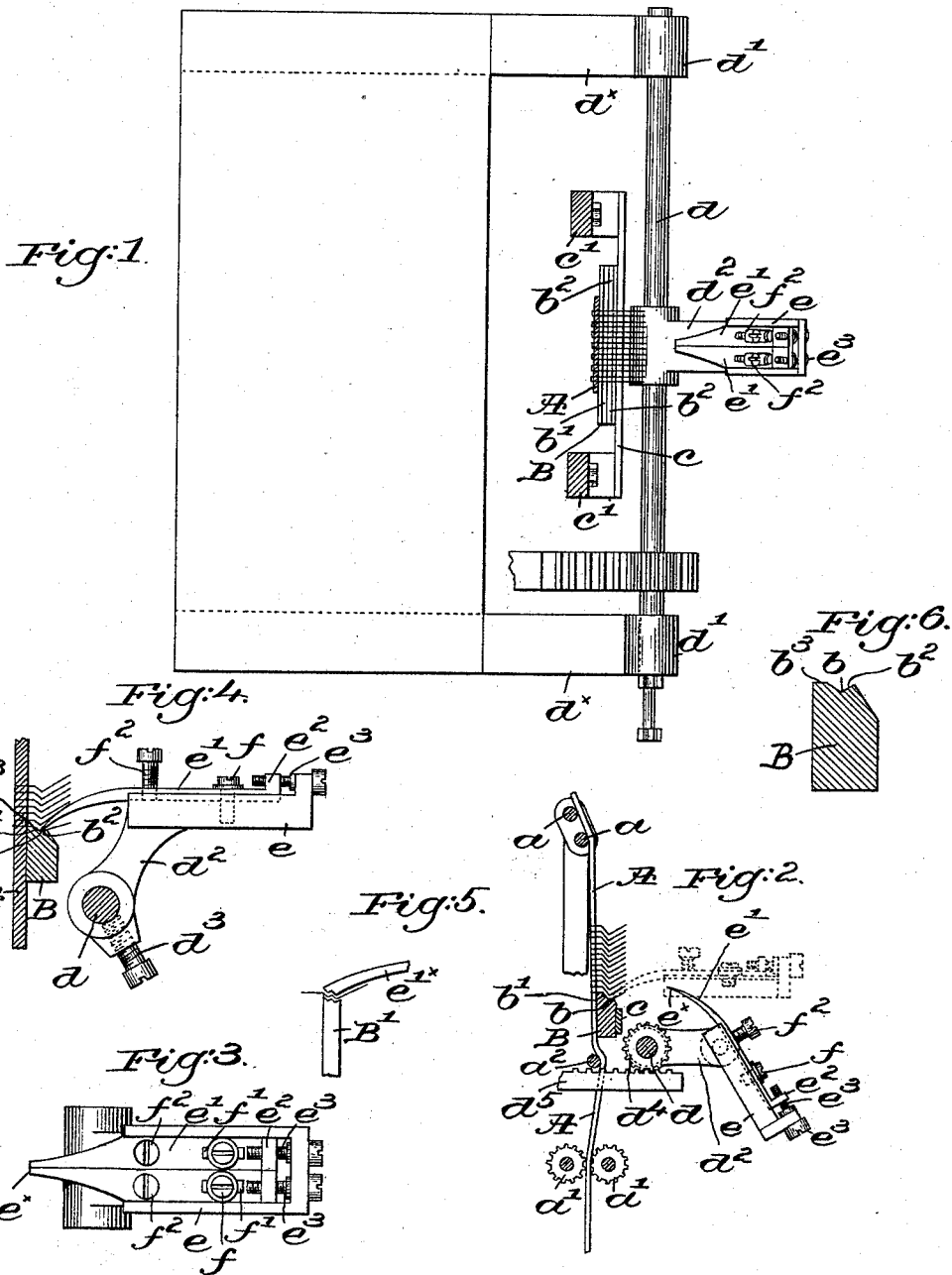

Witnesses.

Louis M. Lowell

Thomas Drummond

Inventor.

Maurice Duesberg Delrez
by Crosby & Suyor att'ys.

UNITED STATES PATENT OFFICE.

MAURICE DUESBERG-DELREZ, OF VERVIERS, BELGIUM.

APPARATUS FOR SETTING TEETH IN CARD-CLOTHING.

SPECIFICATION forming part of Letters Patent No. 526,564, dated September 25, 1894.

Application filed August 8, 1893. Serial No. 482,635. (No model.) Patented in Belgium December 31, 1890, No. 93,303, and February 28, 1891, No. 93,794; in France February 19, 1891, No. 211,538; in Italy February 23, 1891, No. 29,259; in Spain February 25, 1891, No. 11,814; in England March 5, 1891, No. 3,981; in Germany April 10, 1891, No. 60,104, and in Austria-Hungary December 5, 1891, No. 36,746 and No. 61,729.

To all whom it may concern:

Be it known that I, MAURICE DUESBERG-DELREZ, a subject of the King of Belgium, residing at Verviers, Province of Liege, Belgium, have invented an Improvement in Apparatus for Setting Teeth in Card-Clothing, (patented in Belgium December 31, 1890, No. 93,303, and February 28, 1891, No. 93,794; in Germany April 10, 1891, No. 60,104; in France February 19, 1891, No. 211,538; in Italy February 23, 1891, No. 29,259; in England March 5, 1891, No. 3,981; in Spain February 25, 1891, No. 11,814, and in Austria-Hungary December 5, 1891, No. 36,746 and No. 61,729,) of which the following description, in connection with the accompanying drawings, is a specification, like letters on the drawings representing like parts.

This invention has for its object the production of mechanism for setting teeth in card clothing such as shown in United States Patent No. 495,694, granted to me April 18, 1893, the said card clothing being composed of a flexible backing, and teeth inserted therein and having supplementary angles at their bases, and inasmuch as the feeding, cutting, and insertion of the wire into the backing of the clothing may be and are performed by any usual or suitable mechanism, forming no part of this invention, I have not illustrated the same herein. In accordance therewith my invention consists in a machine for setting card teeth, of a matrix, and means to sustain the backing adjacent thereto with the card teeth projecting over said matrix, combined with a bender, and means to move it toward the matrix to deliver a blow upon the projecting teeth, whereby the latter are forced against the matrix and bent to the shape thereof, substantially as will be described.

Other features of my invention will be hereinafter described and particularly pointed out in the claims.

Figure 1, is a top view partly in section, of a sufficient portion of a card tooth setting machine to be understood, and embodying my invention. Fig. 2 is an end view of the mechanism shown in Fig. 1, partly in section. Figs. 3 and 4 are enlarged details in plan and

side elevation, respectively, of the mechanism shown in Figs. 1 and 2. Fig. 5 is a modification of the matrix and bender to be described, and Fig. 6 an enlarged section of the matrix.

Referring to the drawings, I have shown the leather or other material forming the backing A of the card clothing as suspended over suitable guides a and passed between rolls a' , a' , see Fig. 2, preferably corrugated to more readily grasp and control the movements of the backing. The said backing is moved upward by any suitable means, such as a weight upon its leading end, the rolls a' , a' regulating the rapidity of the longitudinal movement of the backing, and being rotated intermittently in the usual manner. The backing is pressed by a guide roll a^2 against the vertical face of a matrix B, its upper surface having a longitudinal groove or depression b therein, see Figs. 1, 2, 4 and 6, formed by the intersection of the two sides b' , b^2 , for a purpose to be described, the matrix being attached to a bridge c secured to brackets c' , c' forming a part of the machine frame.

Lateral motion is imparted to the backing A step by step as each tooth is brought into position to be set, by mechanism of usual and well known construction, in order that the teeth in each horizontal row may be set successively, the backing being moved longitudinally at the completion of each row to present a new row of teeth to be acted upon by the setting mechanism. In setting the teeth each one is bent to form supplemental angles at the base, as described in the patent referred to, so as to present a broken or crooked line.

In forming ordinary card-teeth a hooked tool has been employed to pull the teeth in a downward direction over a suitable tongue and thereby bend it, but in forming the teeth in accordance with my invention, I exert sudden pressure upon the tooth by a blow, delivered by a bender or former, now to be described.

A rock shaft d is supported in suitable bearings d' in brackets d^x forming a part of the frame of the machine, to which shaft is secured an arm d^2 supporting a carrier e grooved or recessed at its upper side, see Figs. 3 and

4, to receive and guide the benders or formers e' upturned at their inner ends to form ears e^2 , through which screws e^3 are extended, by means of which the benders or formers can be adjusted longitudinally and independently. Set screws f are extended through slots f' in the benders into the carrier, whereby the benders can be rigidly secured in adjusted position, and the front ends thereof can be raised or lowered by adjusting screws f^2 . Each bender e' acts upon one of the two legs or branches of a tooth, and by means of the independent adjustment the two legs may be given a slightly different form, and wear of the parts is provided for. As shown in Fig. 4 the arm d^2 is adjustable upon the rock shaft d by a set screw d^3 . In order that the bender, having formed or set the teeth of one row, may not contact therewith improperly when forming the teeth of the next row, I oscillate the bender, and for that purpose I have shown herein a gear d^4 fast on the rock shaft d , in mesh with a reciprocating rack bar d^5 , motion being imparted thereto by a cam or otherwise, whereby the carrier is moved in a circular path toward and from the matrix B as the shaft is rocked. As will be seen by an inspection of Figs. 2 and 4 the front end of the benders e' are curved, the extremities e^x being slightly rounded. The legs of the tooth having been forced into and through the backing A, they are brought into position against the edge b^3 of the matrix, and projecting over it, whereupon the carrier e is oscillated as described and the extremities of the benders strike against the top of the wire, forcing the legs down into the groove b of the matrix and against the sides b' , b^2 thereof, bending the legs in opposite directions and forming the supplemental angles desired, at the same time directing the points upward. Owing to the convexity of the tops of the benders the points of the teeth immediately above and in the preceding row are bent upward slightly, to give them the proper final inclination, while the concave under side of the bender permits free movement of the point of the tooth receiving the blow, as the point will rise when the adjacent part is forced by the blow into the groove b of the matrix. The point is thus protected and cannot be bent during the impact, and when the bender is withdrawn it will not touch the point.

It is obvious that the bends or angles may be altered in number or amplitude by changing the form of the matrix and the end of the bender, as in Fig. 5, wherein two bends in each direction are imparted to the base of the tooth by the matrix B' and bender e'^x .

This invention is not restricted to the precise form or arrangement of parts as herein shown and described, as it is evident that they may be altered or modified without departing from the spirit and scope of my invention.

I claim—

1. In a machine for setting card teeth, a matrix, and means to sustain the backing adjacent thereto with the card teeth projecting over said matrix, combined with a bender, and means to move it toward the matrix to deliver a blow upon the projecting teeth, whereby the latter are forced against the matrix and bent to the shape thereof, substantially as described.

2. In a machine for setting card teeth, a matrix having a groove or depression therein, and means to sustain the backing adjacent thereto with the card teeth projecting over the matrix, combined with an oscillating bender, and means to move it against the teeth and force them into the groove of the matrix, to bend the teeth at their base, substantially as described.

3. In a machine for setting card teeth, a matrix having an edge b^3 , a groove with inclined walls, and means to sustain the backing with the teeth to be set extended over said edge and groove, combined with a bender adapted to deliver a blow upon the teeth and bend them over the edge and into the groove, to form supplemental angles at the base, actuating means for said bender, and adjusting devices to vary the throw of the bender, substantially as described.

4. In a machine for setting card teeth, a matrix to impart the desired shape to the teeth, combined with a bender adapted to force the teeth against said matrix and thereby shape them, the under side of the bender being concave, substantially as and for the purpose described.

5. In a machine for setting card teeth, a matrix to impart the desired shape to the teeth, combined with a bender adapted to force the teeth against the matrix, the top of said bender being convex, to act upon the point of a tooth in the preceding row and adjust its inclination, substantially as described.

6. In a machine for setting card teeth, a matrix to impart the desired shape to the teeth, combined with a bender adapted to force the teeth against the matrix, the top of said bender being convex, to act upon the point of a tooth in the preceding row and adjust its inclination, the bender being curved at its under side to permit free movement of the point of the tooth being set, substantially as described.

7. In a machine for setting card teeth, a rock shaft, a carrier thereon, and independent benders supported by said carrier, combined with means to adjust said benders independently, and a matrix to co-operate with the benders, substantially as described.

In testimony whereof I have signed my name to this specification in the presence of two subscribing witnesses.

MAURICE DUESBERG-DELREZ.

Witnesses:

FR. DEPRIERE,
J. T. LE COSTY.