



US00D679162S

(12) **United States Design Patent**
Aglassinger

(10) **Patent No.:** **US D679,162 S**

(45) **Date of Patent:** **** Apr. 2, 2013**

(54) **ROTARY HAMMER**

(75) Inventor: **Hans-Peter Aglassinger**, Esslingen (DE)

(73) Assignee: **Robert Bosch GmbH**, Stuttgart (DE)

(**) Term: **14 Years**

(21) Appl. No.: **29/415,840**

(22) Filed: **Mar. 14, 2012**

(30) **Foreign Application Priority Data**

Sep. 15, 2011 (EM) 001918087

(51) **LOC (9) Cl.** **08-03**

(52) **U.S. Cl.** **D8/69**

(58) **Field of Classification Search** D8/14.1,
D8/61-70; 81/429, 454-456, 469, 489; 173/104,
173/114, 168-171, 178, 201, 211, 213, 217;
408/20, 124, 125, 234; 388/809

See application file for complete search history.

(56) **References Cited**

U.S. PATENT DOCUMENTS

D447,032	S	*	8/2001	Schoen et al.	D8/67
D470,379	S	*	2/2003	Andriolo	D8/68
D502,377	S	*	3/2005	Aglassinger	D8/69
D555,451	S	*	11/2007	Okuda et al.	D8/69
D594,304	S	*	6/2009	Aglassinger	D8/67
D595,101	S	*	6/2009	Bast	D8/68
D615,838	S	*	5/2010	Aglassinger	D8/69
D618,529	S	*	6/2010	Stirm	D8/69
D625,981	S	*	10/2010	Stirm	D8/69

7,876,004	B2	*	1/2011	Kuhnle et al.	310/50
D645,318	S	*	9/2011	Taniguchi et al.	D8/69
2011/0127056	A1	*	6/2011	Friedrich et al.	173/162.2

FOREIGN PATENT DOCUMENTS

DE 102007026106 A1 * 12/2008

* cited by examiner

Primary Examiner — Philip S Hyder

Assistant Examiner — Darlington Ly

(74) *Attorney, Agent, or Firm* — Maginot, Moore & Beck

(57) **CLAIM**

The ornamental design for a rotary hammer, as shown and described.

DESCRIPTION

FIG. 1 is a perspective view of a rotary hammer showing my new design;
 FIG. 2 is right side elevational view showing the design for the rotary hammer of FIG. 1;
 FIG. 3 is a left side elevational view showing the design for the rotary hammer of FIG. 1;
 FIG. 4 is a front elevational view showing the design for the rotary hammer of FIG. 1;
 FIG. 5 is a rear elevational view showing the design for the rotary hammer of FIG. 1;
 FIG. 6 is a top elevational view showing the design for the rotary hammer of FIG. 1; and,
 FIG. 7 is a bottom elevational view showing the design for the rotary hammer of FIG. 1.

1 Claim, 7 Drawing Sheets

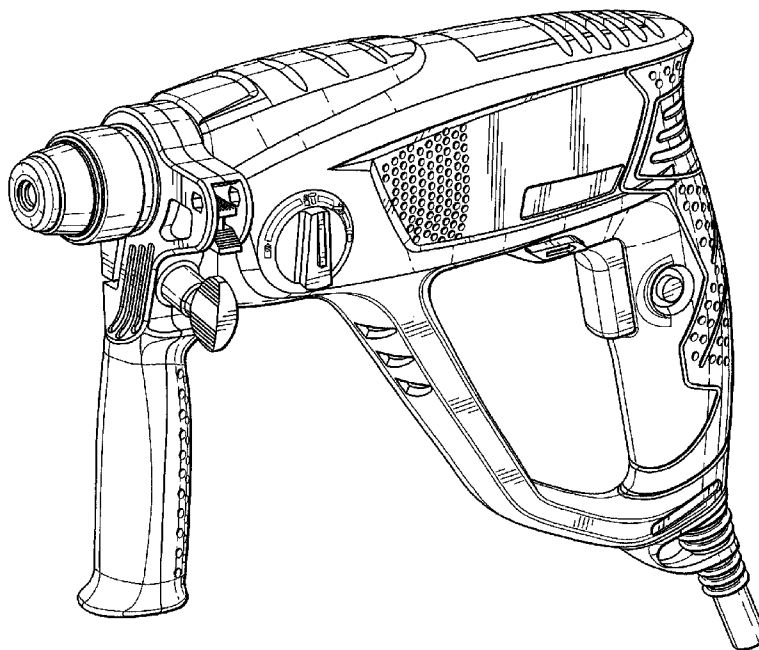

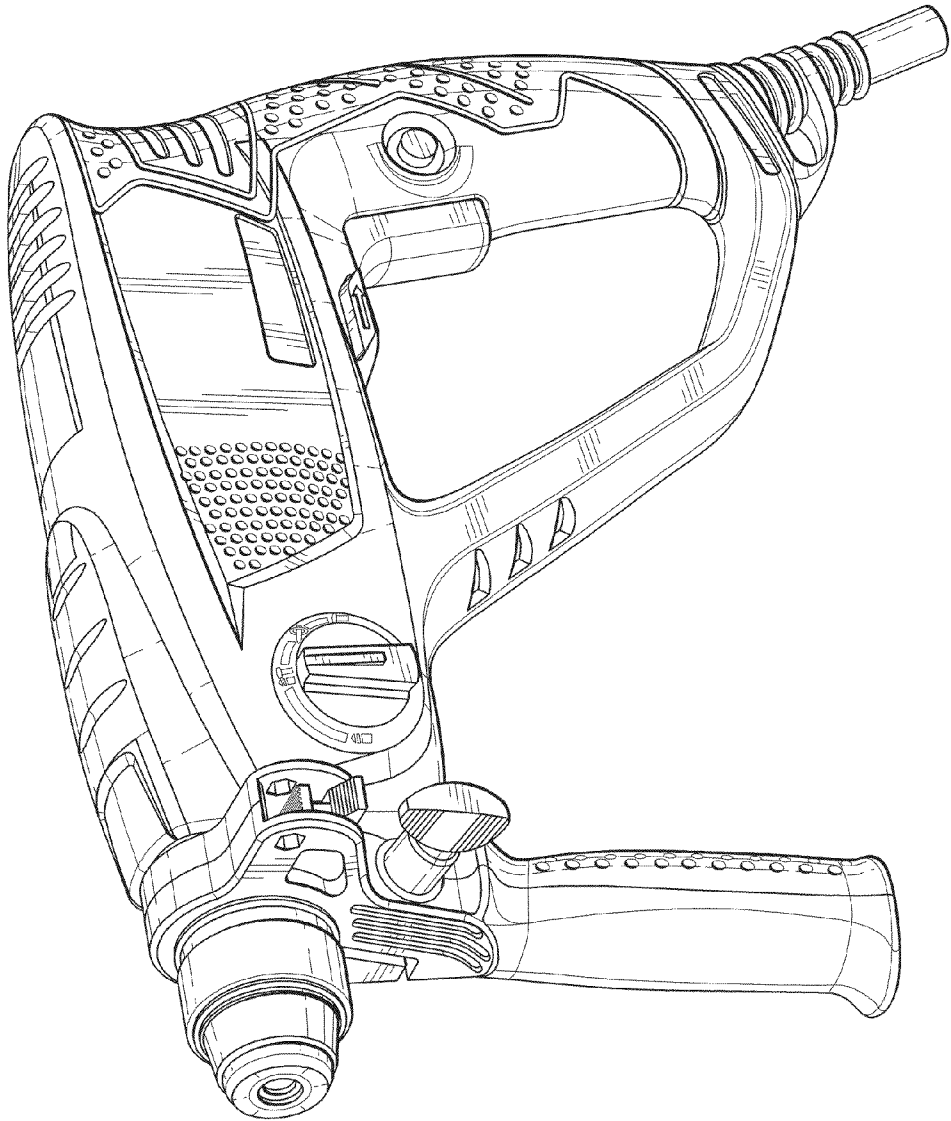

Fig. 1

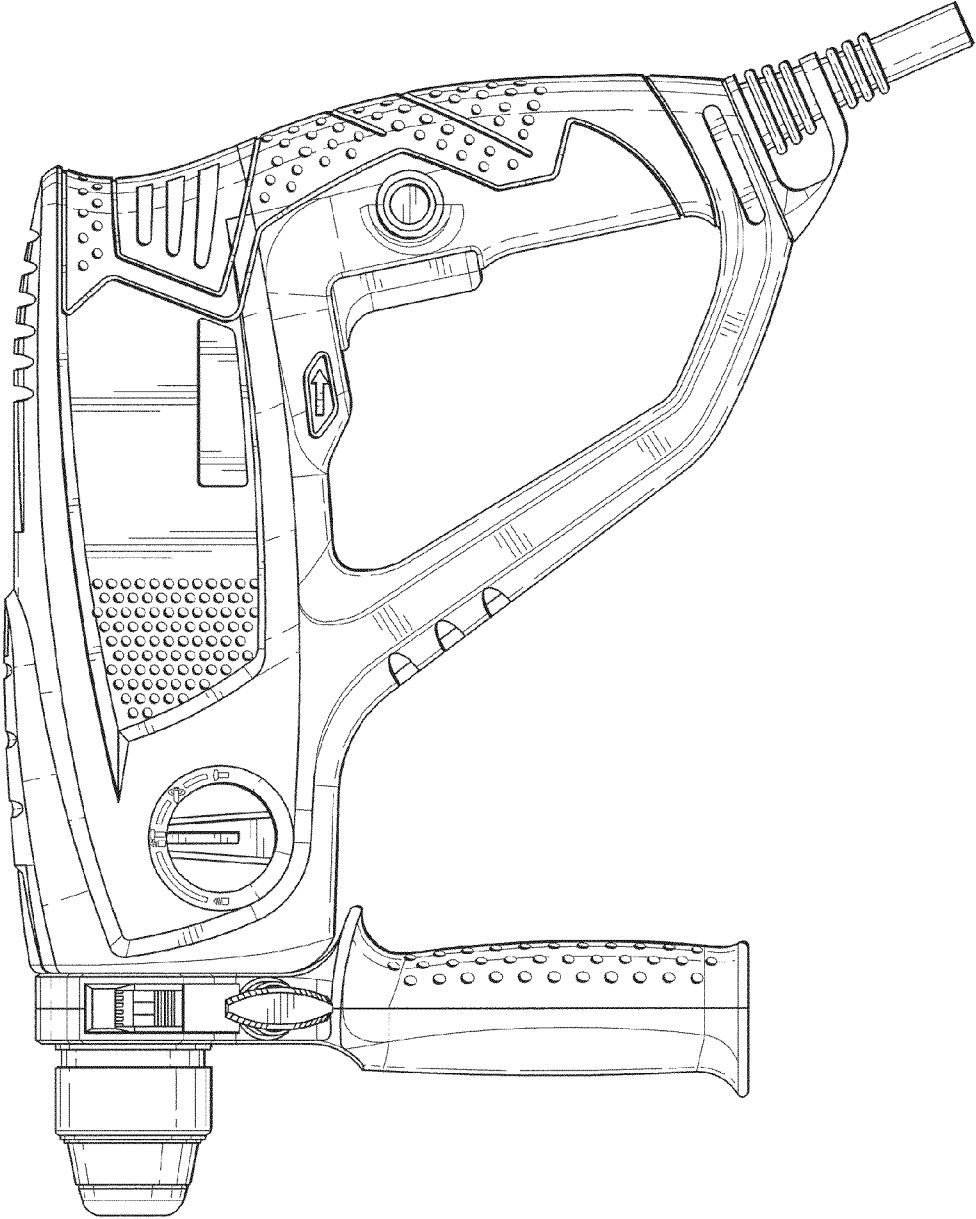

Fig. 2

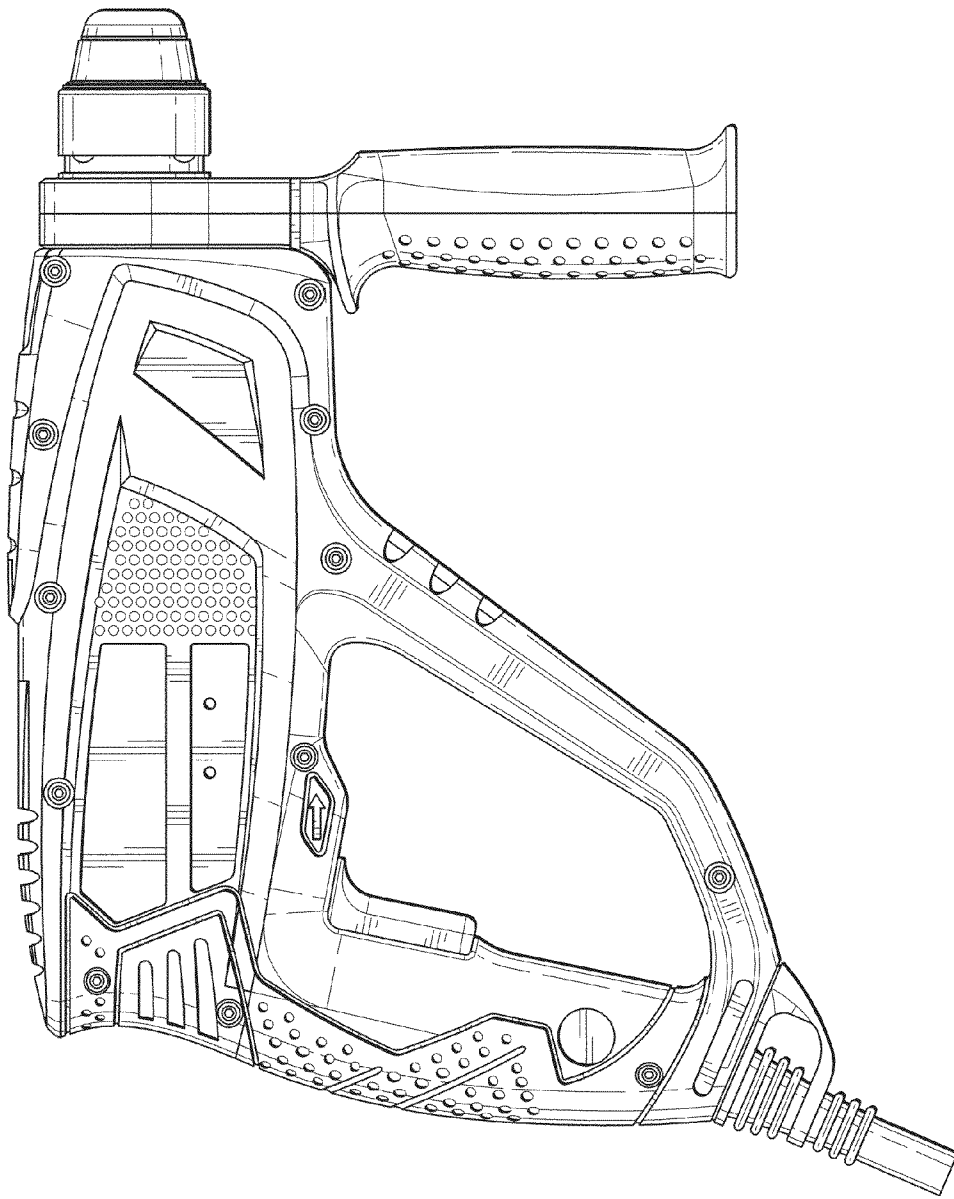

Fig. 3

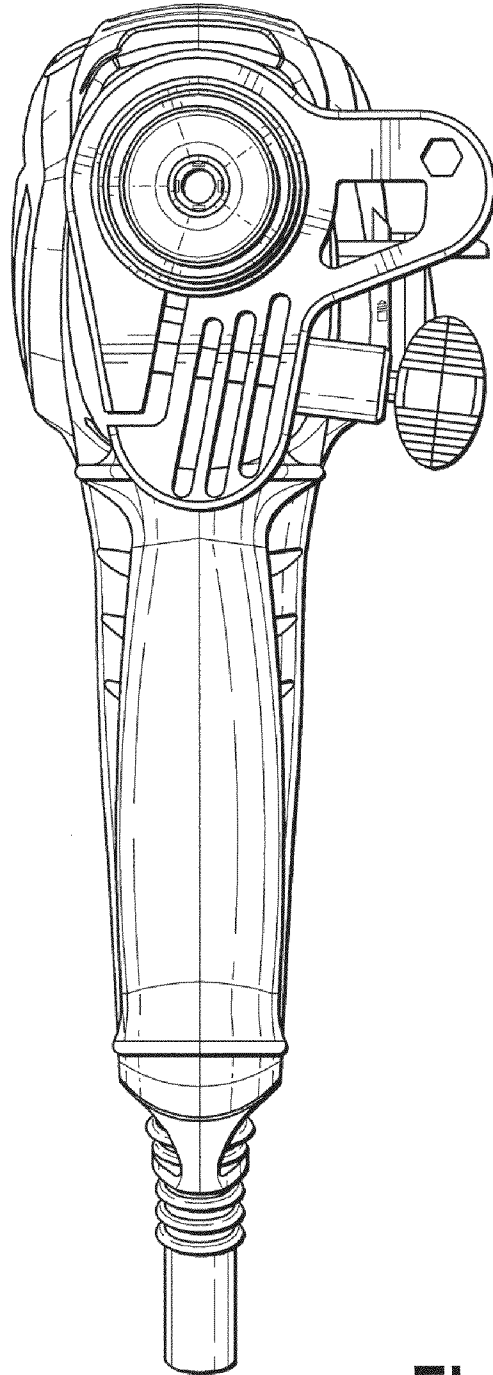

Fig. 4

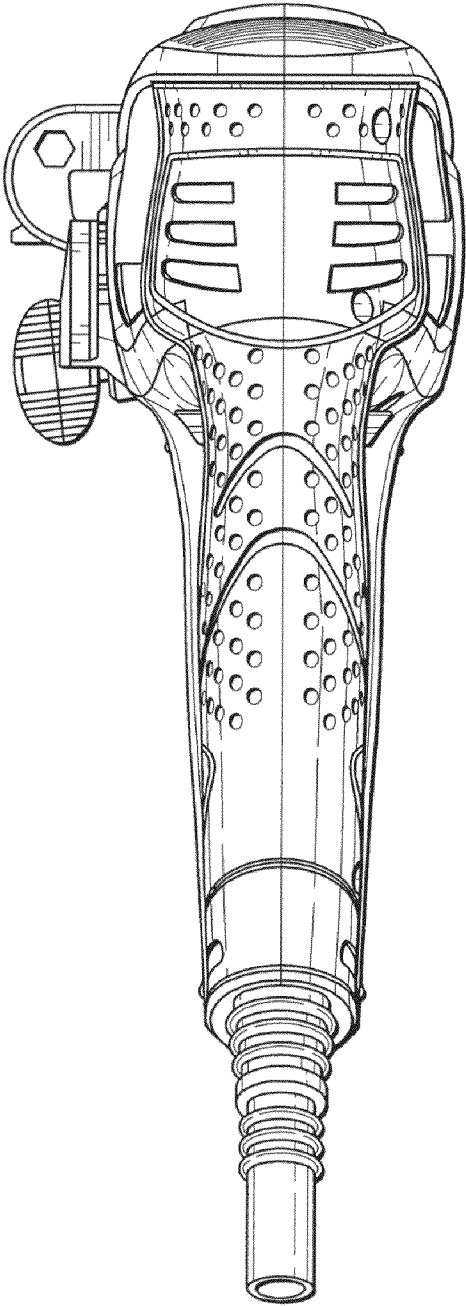

Fig. 5

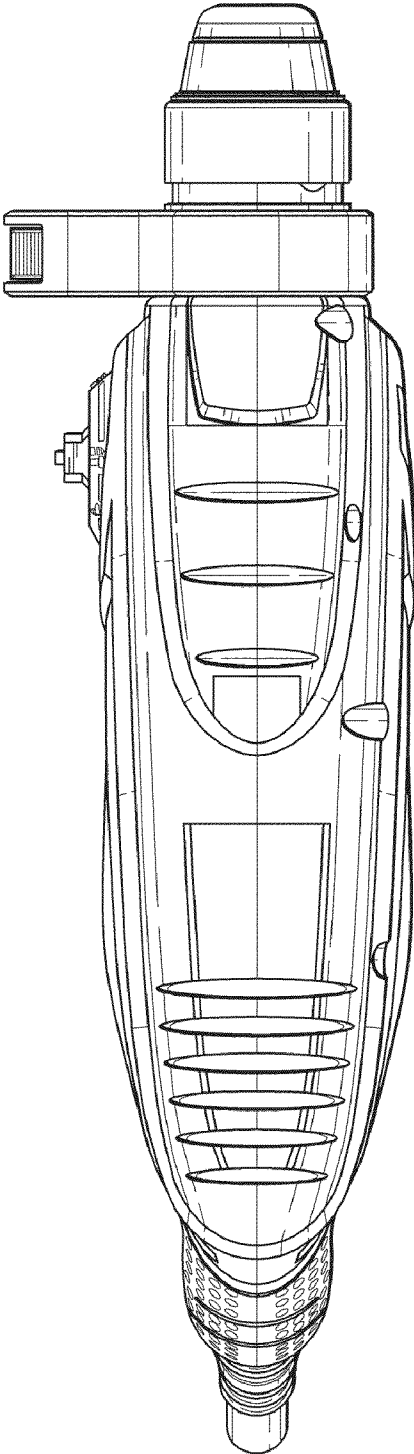

Fig. 6

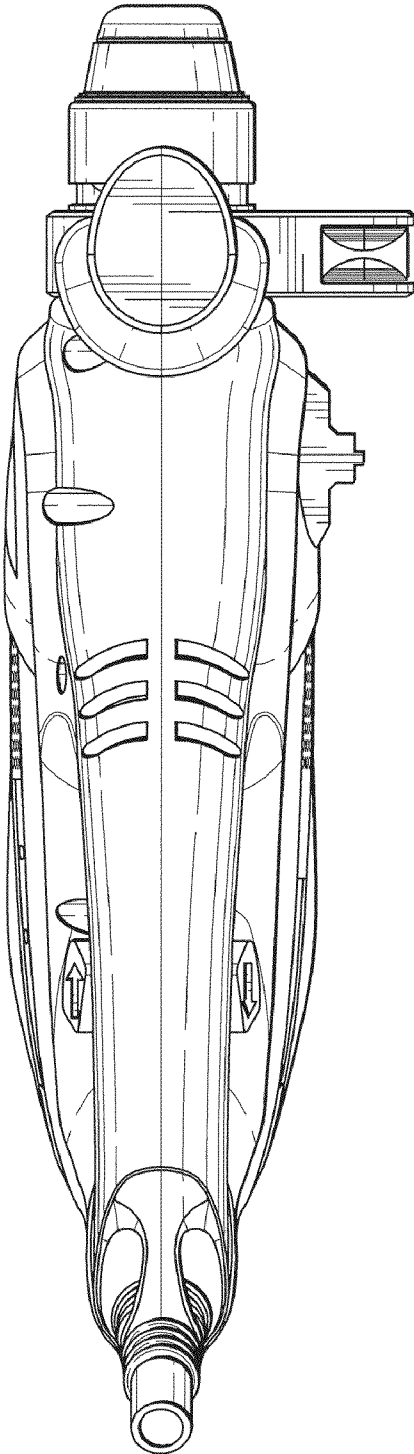

Fig. 7