

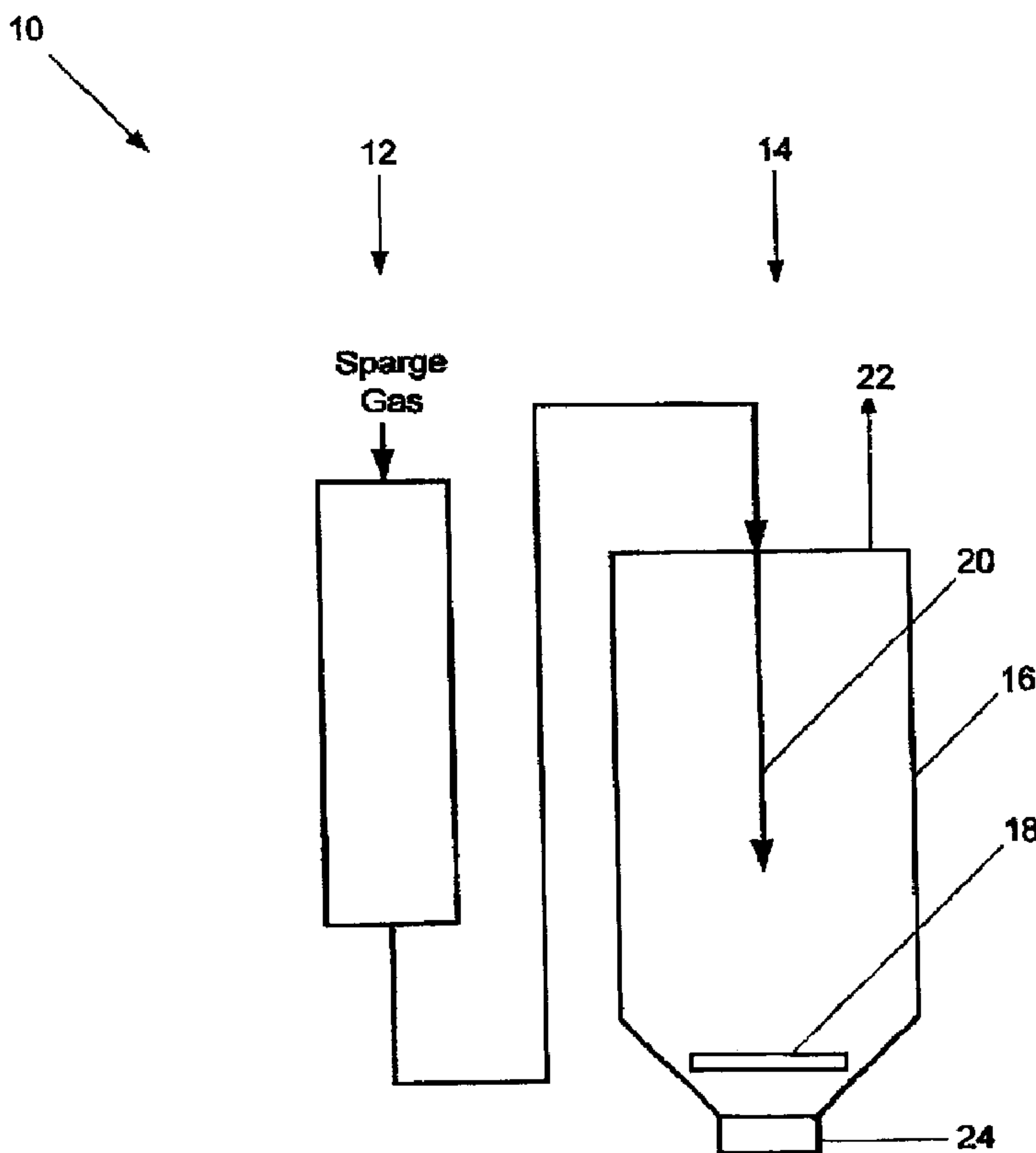

(86) Date de dépôt PCT/PCT Filing Date: 2007/05/01
 (87) Date publication PCT/PCT Publication Date: 2007/11/15
 (85) Entrée phase nationale/National Entry: 2008/10/31
 (86) N° demande PCT/PCT Application No.: US 2007/067950
 (87) N° publication PCT/PCT Publication No.: 2007/130991
 (30) Priorité/Priority: 2006/05/01 (US60/746,105)

(51) Cl.Int./Int.Cl. *B32B 27/12* (2006.01),
B01D 15/00 (2006.01), *B01D 61/00* (2006.01),
B01L 3/00 (2006.01)
 (71) Demandeur/Applicant:
 HORIZON TECHNOLOGY, INC., US
 (72) Inventeurs/Inventors:
 JOHNSON, ROBERT S., US;
 SCHEUFELE, STEPHEN, US
 (74) Agent: GOWLING LAFLEUR HENDERSON LLP

(54) Titre : SYSTEME ET PROCEDE DE PRELEVEMENT D'ECHANTILLON
 (54) Title: SAMPLE COLLECTION SYSTEM AND METHOD



(57) **Abrégé/Abstract:**

An apparatus or method for removing water and concentrating an analyte in solution, wherein the concentrated analyte sample is delivered directly to a vial, such as an autosampler vial that is capable of use in a gas chromatography autosampler.

(12) INTERNATIONAL APPLICATION PUBLISHED UNDER THE PATENT COOPERATION TREATY (PCT)

(19) World Intellectual Property Organization
International Bureau(43) International Publication Date
15 November 2007 (15.11.2007)

PCT

(10) International Publication Number
WO 2007/130991 A1

(51) International Patent Classification:

B32B 27/12 (2006.01) **B01L 3/00** (2006.01)
B01D 15/00 (2006.01) **B01D 61/00** (2006.01)**Robert, A.** [US/US]; 25 Blue Heron Avenue, Hampstead, NH 03841 (US). **SCHEUFELE, Steve** [US/US]; 8 Wheeler Lane, Northboro, MA 01532 (US).

(21) International Application Number:

PCT/US2007/067950

(74) Agents: **GROSSMAN, Steven, J.** et al.; Grossman, Tucker, Perreault & Pflieger, PLLC, 55 South Commercial Street, Manchester, NH 03101 (US).

(22) International Filing Date: 1 May 2007 (01.05.2007)

(25) Filing Language: English

(26) Publication Language: English

(30) Priority Data:

60/746,105 1 May 2006 (01.05.2006) US

(71) Applicant (for all designated States except US): **HORIZON TECHNOLOGY INC.** [US/US]; 45 Northwestern Drive, Salem, NH 03079 (US).

(81) Designated States (unless otherwise indicated, for every kind of national protection available): AE, AG, AL, AM, AT, AU, AZ, BA, BB, BG, BH, BR, BW, BY, BZ, CA, CH, CN, CO, CR, CU, CZ, DE, DK, DM, DZ, EC, EE, EG, ES, FI, GB, GD, GE, GH, GM, GT, HN, HR, HU, ID, IL, IN, IS, JP, KE, KG, KM, KN, KP, KR, KZ, LA, LC, LK, LR, LS, LT, LU, LY, MA, MD, MG, MK, MN, MW, MX, MY, MZ, NA, NG, NI, NO, NZ, OM, PG, PH, PL, PT, RO, RS, RU, SC, SD, SE, SG, SK, SL, SM, SV, SY, TJ, TM, TN, TR, TT, TZ, UA, UG, US, UZ, VC, VN, ZA, ZM, ZW.

(72) Inventors; and

(75) Inventors/Applicants (for US only): **JOHNSON,**

(84) Designated States (unless otherwise indicated, for every kind of regional protection available): ARIPO (BW, GH, GM, KE, LS, MW, MZ, NA, SD, SL, SZ, TZ, UG, ZM,

[Continued on next page]

(54) Title: SAMPLE COLLECTION SYSTEM AND METHOD

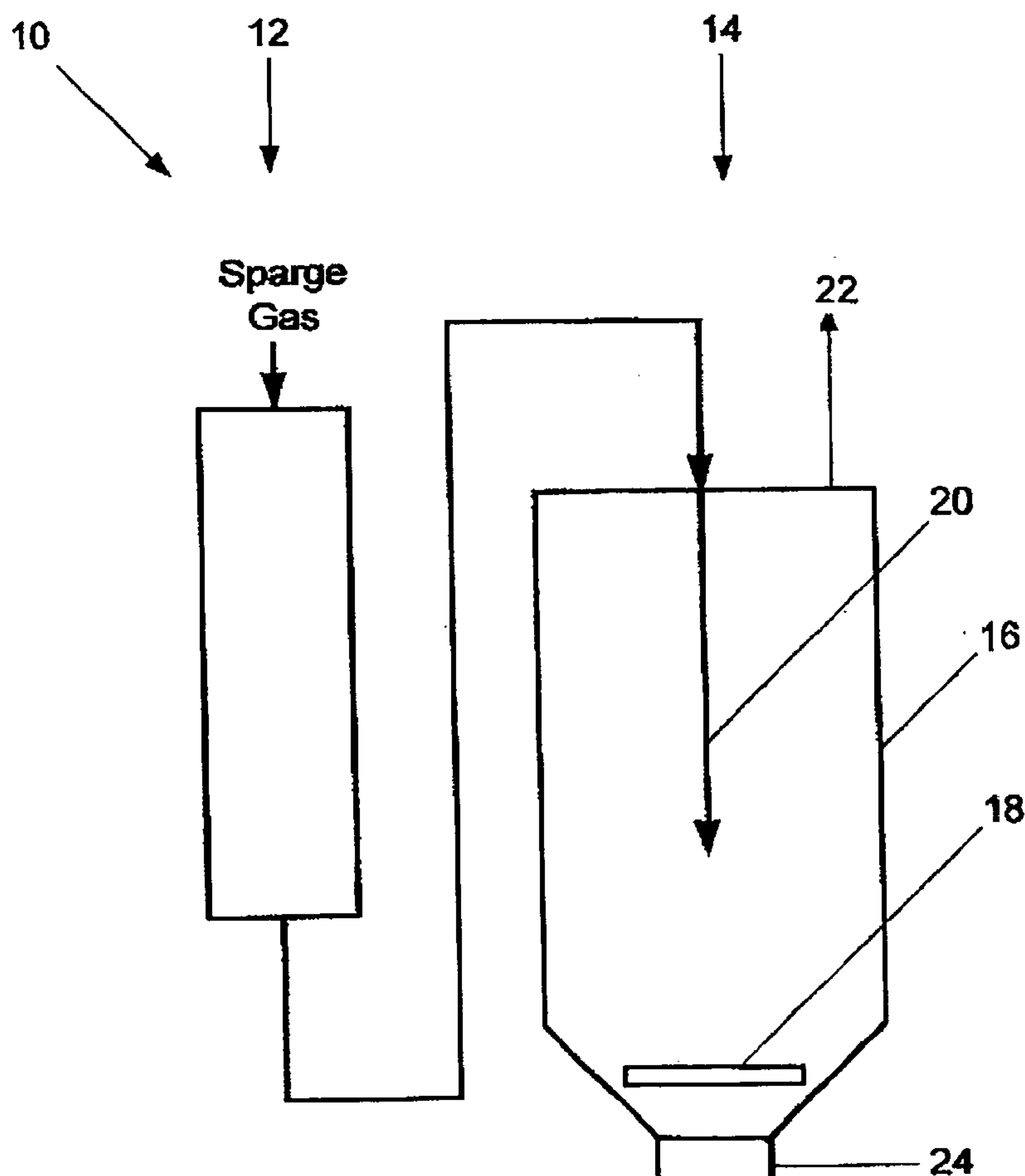

(57) Abstract: An apparatus or method for removing water and concentrating an analyte in solution, wherein the concentrated analyte sample is delivered directly to a vial, such as an autosampler vial that is capable of use in a gas chromatography autosampler.

WO 2007/130991 A1

WO 2007/130991 A1



ZW), Eurasian (AM, AZ, BY, KG, KZ, MD, RU, TJ, TM), European (AT, BE, BG, CH, CY, CZ, DE, DK, EE, ES, FI, FR, GB, GR, HU, IE, IS, IT, LT, LU, LV, MC, MT, NL, PL, PT, RO, SE, SI, SK, TR), OAPI (BF, BJ, CF, CG, CI, CM, GA, GN, GQ, GW, ML, MR, NE, SN, TD, TG).

Published:

— *with international search report*

— *before the expiration of the time limit for amending the claims and to be republished in the event of receipt of amendments*

For two-letter codes and other abbreviations, refer to the "Guidance Notes on Codes and Abbreviations" appearing at the beginning of each regular issue of the PCT Gazette.

Sample Collection System and Method

Cross Reference to Related Applications

The present application claims the benefit of the filing date of U.S. Provisional
5 Application Ser. No. 60/746,105, filed May 1, 2006, the teachings of which are incorporated
herein by reference.

Field

The present disclosure generally relates to the collection and handling of samples for
10 analysis, and more particularly directed at the collection of samples from an evaporative
concentrator system.

Background

When samples need to be analyzed for trace organic compounds, the samples are
15 typically extracted with an organic solvent. Due to selective chemistry, the organic solvents
extract organic compounds from the sample. Extracted compounds, referred to as analytes,
typically cannot be analyzed until residual water is removed from the solvent and the solvent
is evaporated down in volume. Residual water in the solvent should be removed because it
may have an adverse effect on compound analysis. The solvent should be evaporated down
20 in volume to ensure the analytes are present in a concentration within the detection range of
the analytical instrument used for analysis. The individual processes of extraction, removal
of residual water, and evaporation are time consuming and operator dependent, thereby
typically providing inconsistent recovery of analytes. Loss of analytes due to continual
evaporation in unsealed commercial evaporation units may also contribute to inconsistent
25 analyte recovery. Additionally, the need to transfer sample from an evaporation unit to an
analytical instrument may increase the risk of loss and contamination of the sample.

Summary

The present disclosure relates in one exemplary embodiment to an apparatus for
30 removing water and concentrating an analyte in a solvent comprising a reservoir for

containing a first solution of solvent, residual water and an analyte sample, the reservoir having an opening to drain from the reservoir and a hydrophobic membrane layer comprising fluoropolymer material, said membrane layer positioned in series with said opening. A vessel then may be supplied for containing a second solution passed through said membrane, wherein said vessel is capable of reducing the solvent level of said solution. A sample collection vial may be directly connected to the vessel, such as a vial capable of use in a gas chromatography collection autosampler.

The present disclosure also relates in another exemplary embodiment to an apparatus for collecting and handling an analyte sample in solution for analysis. The apparatus includes a first section for removing water from the sample solution and a second section connected to the first section for concentrating the sample in the solution. The second section may also include a neck portion wherein the neck portion is configured to be engaged to a sample collection vial wherein the sample collection vial is capable of providing a sample to, e.g. an automated gas chromatography system.

15

Brief Description of the Drawings

Features and advantages of the present invention are set forth through the description of exemplary embodiments consistent with the present invention, which description should be read in conjunction with the accompanying drawings, wherein:

20 FIG. 1 schematically depicts an embodiment of an evaporative concentration system which may be used in connection with the present invention;

FIG. 2 shows an embodiment of a sample collection system consistent with the present invention;

25 FIG. 3 is a partial sectional perspective view of an embodiment of a sample collection system consistent with the present invention; and

FIG. 4 is a partial cross-sectional illustration of an embodiment of a sample collection system consistent with the present invention.

Detailed Description

30 The present invention provides a system and method for collecting and handling a sample to be analyzed, e.g. via gas chromatography, mass spectroscopy, etc. The sample size

for such testing may generally be relatively small, and may require a specified level of sample purity or concentration. Accordingly the sample may undergo concentration to remove water and excess solvents, e.g., from an extraction process, contaminants, etc., as well as to increase the concentration of the sample. Consistent with the present invention, the sample may be directly concentrated to a desired level or volume directly into a sample vial, e.g., for use with an analytical instrument.

Referring to FIG. 1, according to one embodiment a sample may be collected directly from an evaporative concentration system 10. The evaporative concentration system 10 may generally provide a relatively concentrated sample and facilitate the removal of excess solvents, etc. As shown, in one embodiment, the evaporative concentration system 10 may generally include a first stage 12 for drying the sample, e.g., removing water from the sample. Water removal may be achieved using chemical drying agents, e.g., sodium sulfate, vacuum, dry gas sparging, membrane separation, etc. The dried sample may then be concentrated, e.g., excess solvent may be removed, etc.

Attention is therefore first directed to U.S. Patent No. 6,749,755 whose teachings are incorporated herein by reference. As disclosed therein, an apparatus and method may be provided for separating residual water from a solvent. The device may comprise a reservoir containing a solution comprising solvent containing residual water, the reservoir having an opening to allow the solution to drain from the reservoir. A membrane layer may be provided comprising a layer of fluoropolymer material, wherein the membrane material has an IPA Bubble Point of greater than or equal to 25 psi. The membrane may be positioned in series with the reservoir opening. Vacuum may be generated on one side of the membrane layer wherein the solvent containing water may pass through the membrane layer therein removing water from the solvent to provide a solvent with a water level of less than or equal to 1 ppm.

Attention is also directed to U.S. Appl. No. 11/190,513 whose teachings are also incorporated herein by reference. As disclosed therein, an apparatus and method may be provided for separating water from a solvent and removing the solvent. The method may include providing a solution containing solvent and residual water and an analyte. The solution may be passed through a membrane to reduce water content wherein an analyte is present at a first concentration. This then may be followed by removing solvent from the solution. The membrane may again comprise a material having an IPA Bubble Point of

greater than or equal to 25 psi. In particular, the membrane may include a hydrophobic membrane layer comprising a fluoropolymer material. The water content may also be reduced to less than or equal to 1.0 ppm.

Accordingly, the dried sample may be supplied to a second stage 14 for concentrating the sample, removing excess solvent, etc. For example, the sample may be delivered to an evaporation tube 16, which may include a heater 18, a supply of sparge gas 20, as well as a vacuum takeoff 22. A combination of heat, sparge gas and vacuum may be used to evaporate the solvent from the sample. The concentrated sample may be collected in a lower region 24 of the evaporation tube 16.

Turning to FIGS 2 and 3, an embodiment of a sample collection system, including an evaporation tube 16 coupled to a sample vial 26, is shown. The sample vial 26 may include, for example, a gas chromatography autosampler vial. A gas chromatography autosampler vial may contain a sample for gas chromatography analysis in an automated gas chromatography system. An autosample vial may therefore be understood as a vial that may be suitable for engagement with a robotic arm and/or suitable for use in a tray rotation technique, etc. Such vial may therefore have a threaded portion for a cap and may have an open hole for autosampler use or a solid cap for sample storage. Single piece polypropylene cap and membrane may also be utilized. It is also contemplated herein that the autosampler vials herein may include a crimp top, a snap seal vial or a shell vial. Furthermore, the autosampler vials herein may be of varying size and may utilize septums of appropriate chemical resistance.

The evaporation tube 16 may be connected to the sample vial 26 by a coupling 28. As the sample is processed by the evaporative concentrator system 10, the concentrated sample may be collected directly in the sample vial 26. Such direct collection of the sample in the sample vial 26 may eliminate the need for separately transferring the sample from the evaporation tube 16 to a sample vial 26, from which the sample may be analyzed. Accordingly, there may be a reduction in the time needed for preparing samples. The risk of losing the sample, e.g., via spillage, mishandling, etc., may be reduce or eliminated.

As shown, in one embodiment the evaporation tube 16 and the sample vial 26 may include exteriorly threaded necks 30, 32. The coupling 28 may include cooperating internal threads. The coupling 28 may, therefore secure the evaporation tube 16 and the sample vial 26 to one another. Additionally, the coupling 28 may generally align the necks 30, 32 of the

evaporation tube 16 and sample vial 26 to enable the sample to flow from the evaporation tube 16 into the sample vial 26 without waste, contamination, etc. In various other embodiments, the coupling may include features other than threads for engaging the evaporation tube and sample vial. For example, the coupling and the evaporation tube may include cooperating precision tapers. Additionally, while the coupling may be produced from any suitable material, at least the surface of the coupling engaging the evaporation tube or the sample vial may include a deformable or resilient material, e.g., a plastic material, which may allow a press fit between the coupling and the evaporation tube or sample vial. For example, the resilient material may comprise a material that has a flexural modulus of less than about 300,000 psi and/or an elongation at break of greater than about 50%. The coupling may therefore include an elastomeric material (e.g. material with an elongation of greater than or equal to about 100%) and/or may include resiliently deformable features, such as ribs, etc., for releasably engaging the evaporation tube or sample vial.

Referring also to FIG. 4, the evaporation tube 16 and sample vial 26 may be supported in a cradle 34, e.g., during concentration of the sample, e.g., in an evaporative concentration system 10. As shown, the cradle 34 may support the evaporation tube 16 and sample vial 26 relative to a sensor housing 36. The sensor housing 36 may include one or more sensors that may detect various characteristics of a sample contained in the sample vial 26 during the evaporative concentration process. For example, one or more sensors may be provided for determining a fill level of the sample vial 26 for controlling the extent of the evaporative concentration to achieve a desired final sample volume. Various other characteristics of the sample, or of the sample vial, may also be detected.

As also shown, a cradle spacer 38 may be provided between at least a portion of the evaporation tube 16 and cradle 34. The cradle spacer 38 may have a generally complimentary shape relative to the evaporation tube 16, and may include an opening for receiving at least a portion of the coupling 28 and/or the sample vial 26. More than one cradle spacer may be provided allowing sample vials having different heights to be used, while still achieving a desired positioning of the sample vial relative to the sensor housing. For example, different spacers may maintain the evaporation tube 16 at different respective heights relative to the sensor housing.

It should be understood that, while the present invention has been described by reference to an exemplary embodiment thereof, the invention can be embodied otherwise

without departing from the principles thereof, and such other embodiments are meant to come within the scope of the present invention.

What is claimed is:

1. An apparatus for removing water and concentrating an analyte in a solvent comprising:

a reservoir for containing a first solution of solvent, residual water and an analyte, the
5 reservoir having an opening to drain from the reservoir;

a hydrophobic membrane layer comprising fluoropolymer material, said membrane layer positioned in series with said opening;

a vessel for containing a second solution passed through said membrane, wherein said vessel is capable of reducing the solvent level of said solution;

10 a sample collection vial connected to said vessel.

2. The apparatus of claim 1 wherein said sample collection vial connected to said vessel comprises a gas chromatography autosampler vial which is capable of providing sample to an automated gas chromatography system.

15

3. The apparatus of claim 1 wherein said vessel for containing said second solution passed through said membrane includes a threaded neck portion containing external threads including a coupling having internal threads attached to said threaded neck portion and wherein said sample collection vial includes exterior threads also attached to said
20 coupling.

4. The apparatus of claim 3 wherein said coupling comprises a resilient material.

5. The apparatus of claim 1 further including a cradle to support said vessel and
25 said sample collection vial.

6. An apparatus for removing water and concentrating an analyte in a solvent comprising:

a reservoir for containing a first solution of solvent, residual water and an analyte, the
30 reservoir having an opening to drain from the reservoir;

a hydrophobic membrane layer comprising fluoropolymer material, said membrane layer positioned in series with said opening;

a vessel for containing a second solution passed through said membrane, wherein said vessel is capable of reducing the solvent level of said solution;

a gas chromatography autosampler vial which is capable of providing sample to an automated gas chromatography system;

5 wherein said vessel for containing said second solution passed through said membrane includes a threaded neck portion containing external threads including a coupling having internal threads attached to said threaded neck portion and wherein said gas chromatography collection autosampler vial includes exterior threads also attached to said coupling.

10

7. The apparatus of claim 6 wherein said coupling comprises a resilient material.

8. An apparatus for collecting and handling an analyte sample in solution for analysis comprising:

15

(a) a first section for removing water from said sample solution;

(b) a second section connected to said first section for concentrating the sample in said solution;

20

(c) a neck portion on said second section, wherein said neck portion is configured to be engaged to a sample collection vial wherein said sample collection vial is capable of providing a sample to an automated gas chromatography system.

25

9. The apparatus of claim 1 wherein said neck portion comprises a threaded neck portion containing external threads including a coupling having internal threads attached to said threaded neck portion and wherein said sample collection vial includes exterior threads attached to said coupling.

1/4

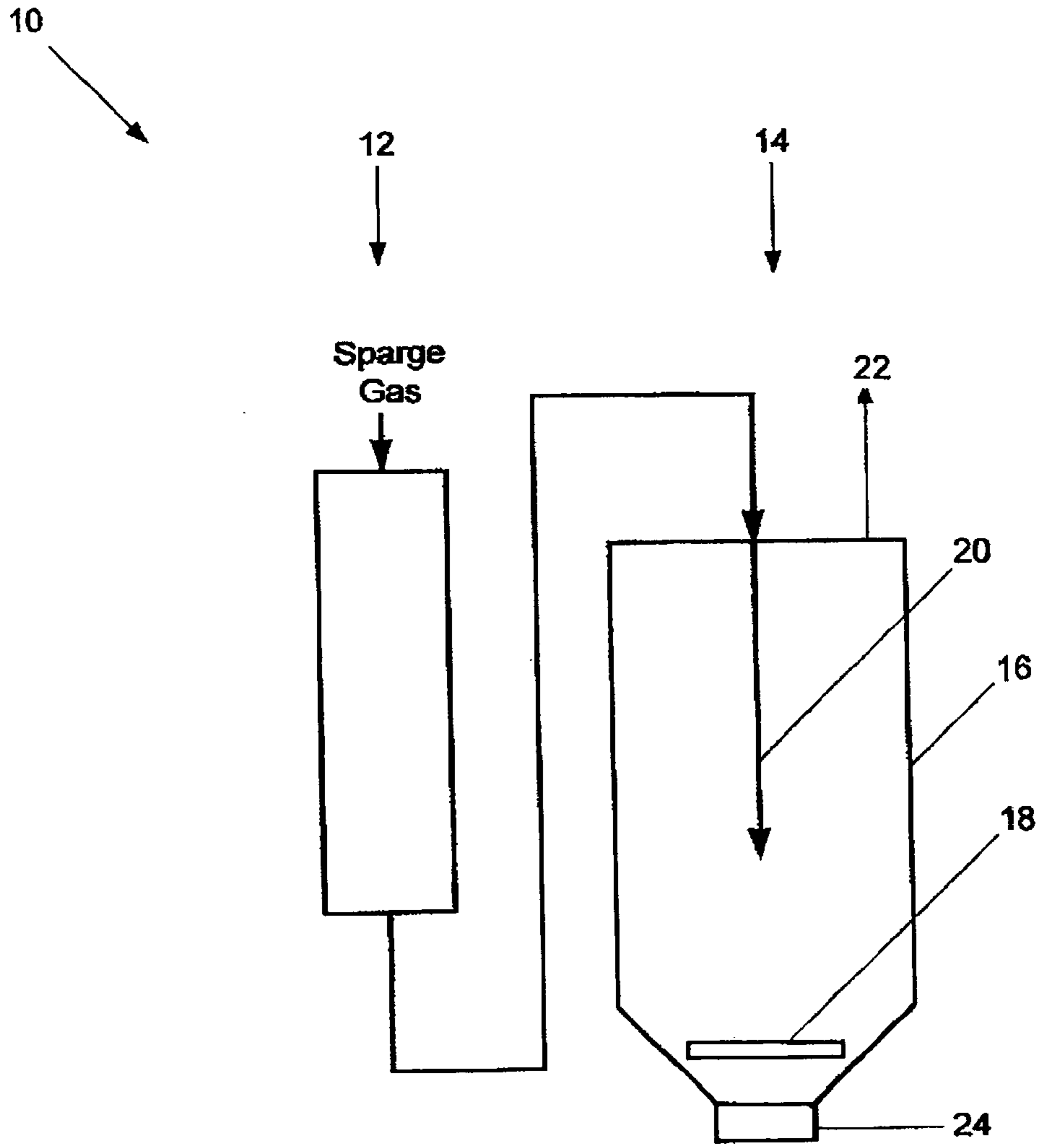

FIG. 1

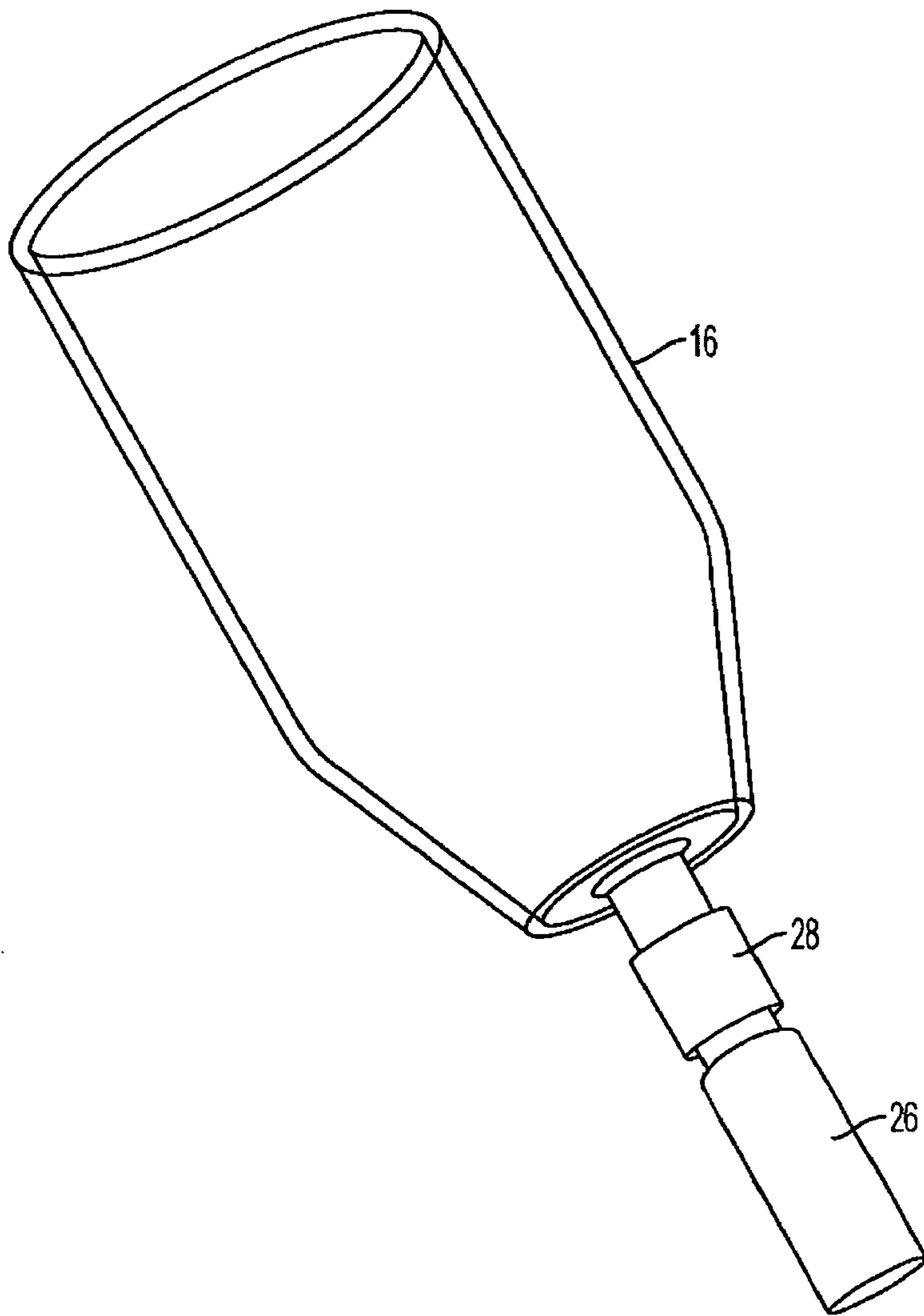

FIG. 2

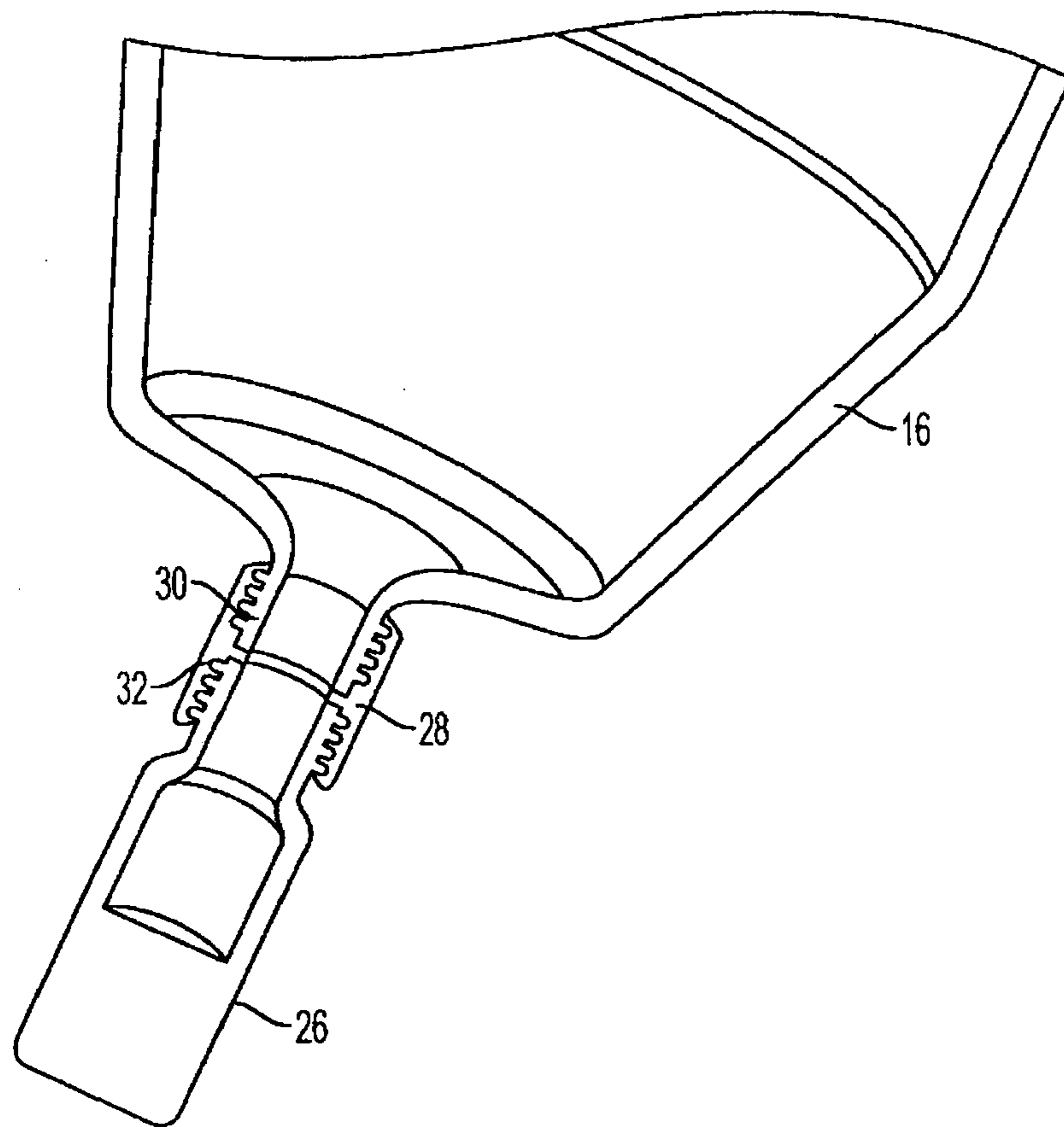

FIG. 3

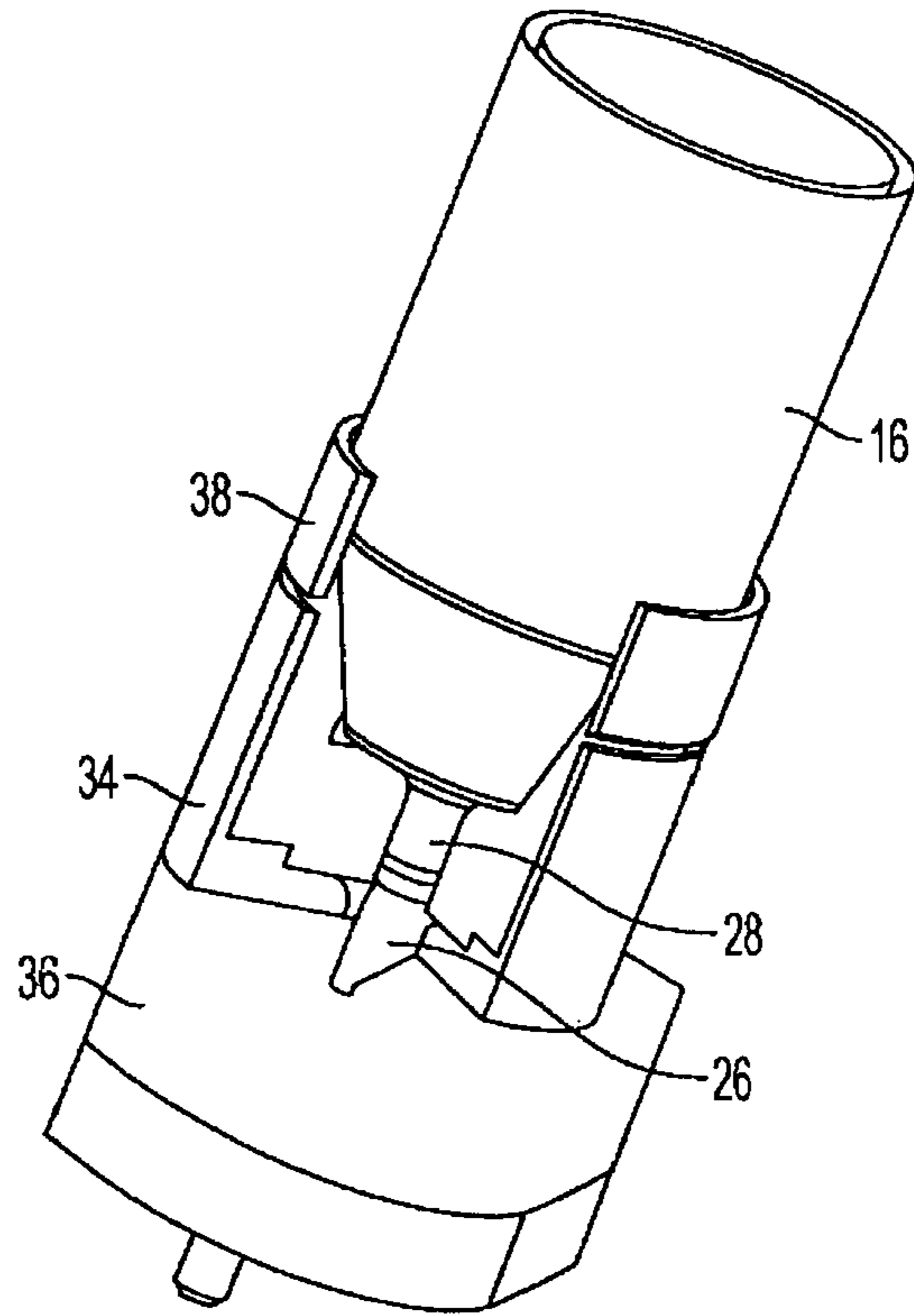

FIG. 4

10

12

14

Spurge
Gas

22

20

16

18

24

