

(19)



Europäisches Patentamt
European Patent Office
Office européen des brevets



(11)

EP 0 583 068 B1

(12)

EUROPEAN PATENT SPECIFICATION

(45) Date of publication and mention
of the grant of the patent:
19.03.1997 Bulletin 1997/12

(51) Int Cl.6: **E01F 13/00**

(21) Application number: **93305430.6**

(22) Date of filing: **09.07.1993**

(54) **Crowd control barrier**

Barriere zum Zurückhalten von Menschenmassen

Barrière pour retenir la foule

(84) Designated Contracting States:
DE ES FR GB GR IE IT NL PT

(30) Priority: **10.07.1992 GB 9214647**
05.05.1993 GB 9309193

(43) Date of publication of application:
16.02.1994 Bulletin 1994/07

(73) Proprietor: **WEMBLEY STADIUM LIMITED**
Wembley, Middlesex HA9 0DW (GB)

(72) Inventors:
• **Jeffs, Noel Lancelot**
Oxhey Watford Hertfordshire (GB)

• **Wicks, Colin**
Uxbridge Middlesex, UB8 3NA (GB)

(74) Representative: **Lerwill, John et al**
A.A. Thornton & Co.
Northumberland House
303-306 High Holborn
London, WC1V 7LE (GB)

(56) References cited:
EP-A- 0 455 410 **GB-A- 2 054 006**

EP 0 583 068 B1

Note: Within nine months from the publication of the mention of the grant of the European patent, any person may give notice to the European Patent Office of opposition to the European patent granted. Notice of opposition shall be filed in a written reasoned statement. It shall not be deemed to have been filed until the opposition fee has been paid. (Art. 99(1) European Patent Convention).

Description

This invention relates to a crowd control barrier for use in sports stadia and other locations where there is a need to avoid mass migration of people from one area to another.

It has become common practice in football stadia to erect perimeter fencing around the playing area to deter pitch invasions by spectators. This fencing is generally of welded metal construction and is frequently in the order of 2 or more metres high, with the result that it impairs the view of some spectators. The fencing may be divided into permanently installed lower sections about 1.2 metres in height and upper sections which can be removed if the stadium is to be used for an event, e.g. a musical concert, at which high fencing is not demanded. With the upper fence sections demounted, audience visibility is not impaired, but the remaining low fence sections do not always provide adequate security against large numbers of people moving from one zone to another e.g. to occupy seats providing a better view but for which they have not paid. In EP-A-0455410 there has been proposed a crowd control barrier comprising a fixed lower section, an upper section pivoted to the lower section, and hydraulic rams for moving the upper section between lowered and raised positions when there is a crowd disturbance. This barrier is relatively expensive to construct and to install, especially if a large number of barriers are needed such as to form a fence around the entire perimeter of a football pitch.

Thus, there still exists a need for a crowd control barrier which is inexpensive to construct and which will provide satisfactory crowd control without impeding clear visibility for spectators or members of an audience located near the barrier. The present invention satisfies this need by providing a crowd control barrier comprising supporting means extending upwardly from the ground and characterised in that spaced lateral frame members extending transversely to the length of the barrier are supported in a common plane above the ground, and elongate flexible elements are connected to and extend between said lateral frame members, there being longitudinal gaps formed between the elongate flexible elements.

In a preferred construction, the flexible elements are wires, cables, cords or the like stretched between the lateral frame members under light tension, these elements being sufficiently strong not to break under the weight of a person attempting to cross the barrier and being arranged to give a little, e.g. by stretching, under such loading to make the barrier very difficult for a person to traverse. The elements are substantially parallel to each other and can be spaced apart by a distance of 15 to 25 cms. Tensioning means may be provided for adjusting the tension in each element.

The lateral frame members can have first ends connected to pivotal mountings, for example carried by fixed support posts, enabling the barrier to be positioned ei-

ther side of the posts. Longitudinal frame members interconnecting the ends of the lateral frame members may be adjustable in length, and the longitudinal and/or lateral members may be fitted with freely rotatable means, e.g. rollers or sleeves to make them difficult for a person to stand on.

The barrier of the invention is not intended positively to prevent a person climbing across it, but it will discourage people from attempting to cross and at least substantially slow the progress of a person determined to cross the barrier whereby stewards deployed within a stadium will have adequate time to deal with a crowd disturbance situation before a mass migration of people occurs. Of course, from a safety aspect, it is beneficial that the barrier is not impossible to cross as this may be desirable in an emergency situation where crowd safety might be threatened.

A clear understanding of the invention will be gained from the following detailed description of some embodiments, reference being made to the accompanying drawings, in which:-

Figure 1 shows in perspective two barriers arranged to define a gateway to provide controlled access between two areas, e.g. between playing and spectator areas within a sports stadium.

Figure 2 is a top plan view illustrating a second embodiment and showing a series of barrier sections with a gateway formed between two adjacent sections;

Figure 3 is a front elevation showing the gate of the second embodiment;

Figure 4 is a partially exploded perspective view of a series of barrier sections, including the gate section, according to the second embodiment;

Figure 5 is a detail plan view showing the attachment of the flexible cables to the lateral barrier frame members;

Figure 6 is an enlarged cross-section taken along the line V-V in Figure 5; and

Figure 7 is a sketch illustrating an alternative arrangement for attachment of the cables to the lateral frame members.

The barrier assembly illustrated in the Figure 1 forms just one part of a perimeter fence extending around an area 10 enclosed by the fence. The perimeter fence includes spaced vertical posts 11 fixed into the ground, and low panels e.g. 0.9 metres in height, which may be permanently mounted between the posts (only the top and bottom rails 12, 13 of the panels have been shown in the drawing). Solid panels between the posts are not essential and one or more horizontal bars would be adequate. Two adjacent posts are separated by a smaller distance and the space between them may be closed by a hinged gate 14. Two barriers 15, 16 each constructed in accordance with the present invention, are respectively associated with the fence sections on

either side of the gate. Each barrier includes a frame with a pair of lateral members 19, 20 extending transversely of the fence. The inner ends of the lateral frame members are releasably interlocked with respective fence posts 11, e.g. by downwardly directed projections on the frame members engaging in sockets in the tops of the posts, and the outer ends of these members are connected by a longitudinal frame member 21. The outer side of the frame is supported by legs 22 which may be adjustable in height. The leg height is substantially the same as the height of the fence posts 11 so that the frame members 19, 20, 21 lie in a substantially horizontal plane about 1.2 metres above ground level. Diagonal struts are fixed between the lateral frame members 19, 20 and the lower ends of the legs for strengthening the frame. In addition the legs are connected by horizontal bars 23 at approximately mid height to add further strength and to deter persons from entering under the frame from the area 10. Extending between the lateral frame members 19, 20 is a series of longitudinally extending parallel flexible elements 24 spaced from each other at a distance, e.g. 15-25 cms, so that they can only be walked across with considerable skill and a person can not readily pass between adjacent elements to reach the space on the underside of the barrier. The exact number and form of the elements 24 is not crucial. They may be wires, cables, cords, chains or the like. Preferably they will be arranged to stretch or give slightly in some other way under the weight of a person, but without any risk of breaking, so as to increase the difficulty of crossing the barrier. The elements may be elastic or sprung in some way to impart this resilience. In an especially convenient construction the elements 24 are formed by a single length of metal wire cable threaded through holes in the lateral frame members and suitably secured at its ends.

As shown, the confronting lateral frame members of the adjacent barriers are non-linear and bent in complimentary shape to define a non-linear passageway leading to the gate. Shaping the passage in this way can assist in slowing down flow of people passing through the gate which may be desirable in the interest of crowd control. It will be appreciated that in other barriers not required to define gateways, the lateral frame members 19, 20 will both be rectilinear and normal to the fence. Barriers according to the invention may be associated with each and every fence panel around the enclosed area 10. Alternatively they may be provided only at those fence sections where crowd control is anticipated to be necessary. Of course adjacent barriers will be in close proximity to avoid gaps through which persons climbing over the fence might pass.

In the illustrated installation each of the barriers 15, 16 has an additional frame 28 extending to the side of the fence remote from the first frame. In similar fashion this additional frame includes lateral members 29, 30 releasably interlocked with the fence posts 11 and interconnected by a longitudinal frame member 31, legs 32

and bracing struts between the legs and lateral frame members. This additional frame 28 acts to deter spectators from approaching the main barrier and provides a zone within which a steward may be stationed.

Because the barrier frames are merely slotted into the fence posts, the barriers can easily be removed in such a case where crowd disturbance is unlikely and the space immediately inside the fence within the area 10 is required for the particular event taking place.

As previously explained, the barrier of the invention is not intended to present an insurmountable obstacle to a determined person wanting to cross the fence. Nonetheless, it will deter and impede persons so that rapid crossings by large numbers of people should not occur and stewards will have time to deal with crowd disturbances in a controlled manner.

The fact that the barrier of the invention allows unimpeded view of an event taking place can also be of financial benefit in that higher prices may be charged for seats located where visibility would be affected by a high fence.

Another form of control barrier in accordance with the invention is illustrated in Figures 2 to 7. As with the first embodiment, the crowd control barrier assembly shown in these Figures forms just part of a perimeter fence extending around an area enclosed by the fence, and the barrier is adapted for installation with an existing perimeter fence having spaced vertical posts fixed into the ground and panels mounted between the posts. Two of the posts 11 (Figure 3) are separated by a shorter distance and the gap between them can be closed by a hinged gate 14. Barrier sections 115, 116, 117 (only three shown) are located on either side of the gateway, each section being associated with a respective section of fence extending between adjacent fence posts 11. Each barrier section includes a rectangular frame with a pair of lateral members 119, 120 extending substantially horizontally and transversely to the fence, and a pair of longitudinal members 118, 121, each frame member consisting of a tubular rod or bar of circular cross-section, and the ends of the bars being interconnected by tubular corner elements 140, 141 of L, T and + form as appropriate for each connection into and/or onto which elements the bars are fixed by transverse bolts. It will be noted that barrier sections immediately adjacent each other share a lateral frame member so that along a continuous run of barrier sections the number of lateral frame members 119, 120 is only one more than the number of sections. The frame corner elements 140 connecting the inner longitudinal members 118 and lateral members 119, 120 have additional laterally projecting limbs 143 which are pivotally connected to respective brackets 144 which are fixed to the fence posts 11, by spigots fastened to the brackets being inserted into sockets provided in the upper ends of the posts. This pivotal connection between the barrier and the fence means that the barrier can be swung through 180° from a position extending to one side of the fence,

which may be appropriate for some events taking place in the stadium or arena in which the fence and barrier are located, to a position extending laterally to the other side of the fence which may be more suitable for other events.

Mounted on the outer longitudinal frame members 121 by respective sleeves 145 are vertical legs 122. The sleeves 145 are rotatable about the members 121 and are locked in place by vertical through bolts enabling the legs to be positioned as illustrated, or at 180° from these positions when the barrier is turned over onto the other side of the fence. The lower end of each leg is equipped with a telescopic foot 146 which allows the effective length of the leg to be adjusted and which is fixed in position after adjustment by a clamp bolt inserted through a transverse hole at the lower end of the leg. As illustrated a respective leg is positioned adjacent the outer end of each lateral frame member 119, 120, but additional legs could be provided if necessary to give greater support and rigidity to the barrier frames. The elongate structural frame members are equipped with loosely fitted plastic sleeves which may be continuous along the frame members or in the form of separate sleeve segments or rollers. The longitudinal frame members 118, 121 could have single continuous sleeves but all frame members preferably have divided sleeves 148, e.g. about 30 cms long. The sleeves are freely rotatable on the frame members and are provided to make it more difficult for a person to climb onto and traverse the barrier.

Extending between each pair of spaced lateral frame members 119, 120 is a group of parallel flexible elements consisting of plastic coated steel wire cables 124. The spacing and number of cables, as well as their tension and elastic modulus, are chosen so that the barrier is very difficult for a person to cross quickly, as explained above in connection with the Figure 1 embodiment. The cables 124 can be secured to the lateral barrier frame members in any convenient manner. Referring to Figures 5 and 6, an attachment rail 150 is fastened to the frame member and as may be seen in Figure 5 the rail is bent or fabricated to form three mounting portions 151 which are bolted to the frame member 119, 120, and two equal sections intermediate the mounting portions and having fixed thereto attachment hooks or eyes 152 according to the spacing between the cables. The ends of the cables 124 are looped through the respective eyes and secured back upon themselves. Preferably each cable comprises a device (not shown) for adjusting the tension in the cable, which may be a device known per se, such as a screw shackle. As may be seen clearly in Figures 5 and 6, the rail sections carrying the eyes 152 are spaced from the frame member 119, 120 to accommodate the sleeve segments 148. It will be understood that those frame members 119, 120 common to adjacent barrier sections will be provided with two cable attachment rails mounted on opposite sides of the frame member for connection of the cables of each bar-

rier section. Other frame members, such as those defining the gateway, will need and be equipped with a single cable attachment rail 150.

An alternative arrangement for attaching the cables is shown in Figure 7. The eyes 160 for the cables are fixed, e.g. by screws, to collars 162 which surround the frame member 119, 121 and are arranged alternately along the frame member with the rotatable sleeve segments 148. Alternatively, the eyes 160 could be fixed directly to the lateral frame members 119, 120, e.g. by welding or screw fixing.

The longitudinal frame members 118, 121 are preferably adjustable in length, conveniently achieved by a telescopic construction, to allow for variations in distances separating adjacent fence posts 11, which can occur due to normal tolerances, in particular where the perimeter fence incorporates curved as well as straight sections.

The gate 14 is also provided with a barrier section 163. A U-shaped barrier frame 164 is fastened to the gate at a height, slightly below that of the main barrier frame members 118-121, this frame extending horizontally from the gate to define lateral members 165 and a longitudinal member 166. A series of parallel, flexible, plastic coated steel wire cables 124 extend between the lateral members and may be connected to these members as described above. If desired the gate frame members can also be equipped with sleeve rollers as described above. The gate barrier does not interfere with normal operation of the gate since when the gate swings open this barrier will pass below the adjacent fixed barrier section 115, as depicted in broken line in Figure 2. If required, the gate barrier frame 160 may be used to mount a stewards seat.

It is not essential that a fixed perimeter fence be provided for supporting the crowd control barrier of the invention and alternatively supporting legs similar to legs 122 could be provided to support the longitudinal members 118. These legs could be fixed permanently in the ground, or where a temporary barrier is to be erected they may merely rest on the ground like the legs 122. The crowd control barrier as described above will act as a substantial obstacle and impediment to persons wishing to traverse the barrier, so that rapid migration of many persons across the barrier will not occur. The barrier position can easily be changed due to the pivotal mounting of the barrier frames. Furthermore, the construction of the frames and the method of attachment of the cables facilitates dismantling and reassembly of the barrier should this be desirable.

Claims

1. A crowd control barrier for restricting passage of people from an area on one side of the barrier to an area on the other side of the barrier, the barrier including supporting means extending upwardly from

the ground, characterised in that spaced lateral frame members (19,20; 119,120) extending transversely to the length of the barrier are supported in a common plane above the ground, and elongate flexible elements (24; 124) are connected to and extend between said lateral frame members, there being longitudinal gaps formed between the elongate flexible elements.

2. A crowd control barrier according to claim 1, wherein the flexible elements (24; 124) are substantially parallel to each other.

3. A crowd control barrier according to claim 2, wherein the flexible elements (24; 124) are spaced apart by a distance of between 15 and 25 cms.

4. A crowd control barrier according to claim 1, 2 or 3, wherein the flexible elements (24; 124) comprise metal wire cables.

5. A crowd control barrier according to any one of claims 1 to 4, wherein the flexible elements are provided with means for adjusting the tension in the flexible elements.

6. A crowd control barrier according to any one of claims 1 to 5, wherein the lateral frame members (19,20; 119,120) are supported to lie in a substantially horizontal plane.

7. A crowd control barrier according to any one of claims 1 to 6, wherein the lateral frame members have first ends for connection to the supporting means (11) and second ends interconnected by a longitudinal frame member (21; 121).

8. A crowd control barrier according to claim 7, wherein the first ends of the lateral frame members (119, 120) are connected together by a longitudinal frame member (118).

9. A crowd control barrier according to claim 7 or 8, wherein the inner ends of the lateral members (119, 120) are coupled to pivotal mountings (144) enabling the frame members to be turned to extend laterally to either side of the supporting means (11).

10. A crowd control barrier according to any one of claims 7 to 9, wherein one or more legs (22; 122) are attached to the frame members for providing support therefor at a position remote from the supporting means (11).

11. A crowd control barrier according to claim 10, wherein each leg (122) is adjustably mounted to the frame members for changing the position of the leg when the lateral frame members are pivoted to ex-

tend from one to the other side of the supporting means (11).

12. A crowd control barrier according to claim 10 or 11, wherein each leg (122) is adjustable in length.

13. A crowd control barrier according to any one of claims 7 to 12, wherein the or each longitudinal frame member (118, 121) is adjustable in length.

14. A crowd control barrier according to any one of claims 7 to 13, wherein the frame members comprise rectilinear tubes joined together by corner connectors (140, 141).

15. A crowd control barrier according to any one of claims 1 to 14, wherein at least one frame member (118, 119, 120, 121) is surrounded by a freely rotatable means (148).

16. A crowd control barrier according to claim 15, wherein the freely rotatable means comprises several independently rotatable sleeve segments (148).

17. A crowd control barrier according to any one of claims 1 to 16, wherein the flexible elements (124) are connected to at least one lateral frame member by a rail (150) releasably attached to the lateral frame member.

18. A crowd control barrier according to any one of claims 1 to 17, wherein a plurality of barrier sections (115, 116, 117) is arranged to form a continuous barrier assembly, each barrier section having flexible elements (124) extending between lateral frame members (119, 120) and immediately adjacent barrier sections sharing a common lateral frame member to which the flexible elements (124) of both sections are connected.

Patentansprüche

1. Eine Publikumskontrollbarriere zum Beschränken von Personenlaufwegen von einem Bereich an einer Seite der Barriere an einen Bereich an der gegenüberliegenden Seite der Barriere, wobei die Barriere eine Stützvorrichtung vom Boden aufwärts beinhaltet, dadurch gekennzeichnet, daß im Abstand ausgeführte Seitenrahmenteile (19, 20; 119, 120), die quer zur Länge der Barriere ausgeführt sind, auf gemeinsamer Ebene über dem Boden abgestützt werden und verlängerte flexible Elemente (24, 124) mit besagten Seitenrahmenteilen verbunden und dazwischen verlaufend ausgeführt sind, wobei sich Längsabstände zwischen den verlängerten flexiblen Elementen bilden.

2. Eine Publikumskontrollbarriere nach Anspruch 1, wobei die flexiblen Elemente (24, 124) größtenteils parallel zueinander verlaufen.
3. Eine Publikumskontrollbarriere nach Anspruch 2, wobei die flexiblen Elemente (24, 124) im Abstand von zwischen 15 und 25 cm voneinander ausgeführt sind.
4. Eine Publikumskontrollbarriere nach Anspruch 1, 2 oder 3, wobei die flexiblen Elemente (24, 124) aus Metalldrahtkabeln bestehen.
5. Eine Publikumskontrollbarriere nach einem der Ansprüche 1 bis 4, wobei die flexiblen Elemente mit Vorrichtungen zum Einstellen der Spannung der flexiblen Elemente ausgeführt sind.
6. Eine Publikumskontrollbarriere nach einem der Ansprüche 1 bis 5, wobei die Seitenrahmenteile (19, 20; 119, 120) zum Ruhen auf größtenteils horizontaler Ebene abgestützt werden.
7. Eine Publikumskontrollbarriere nach einem der Ansprüche 1 bis 6, wobei die Seitenrahmenteile erste Enden zum Anschluß an die Stützvorrichtung (11) und zweite Enden vorsehen, die mit einem Längsrahmenteil (21, 121) verbunden werden.
8. Eine Publikumskontrollbarriere nach Anspruch 7, wobei die ersten Enden der Seitenrahmenteile (119, 120) durch ein Längsrahmenteil (118) miteinander verbunden werden.
9. Eine Publikumskontrollbarriere nach Anspruch 7 oder 8, wobei die inneren Enden der Seitenteile (119, 120) mit Gelenkbefestigungen (144) verkoppelt sind, wodurch es den Rahmenteilen ermöglicht wird, so gedreht zu werden, daß sie sich der Länge nach an beiden Seiten der Stützvorrichtung (11) ausdehnen können.
10. Eine Publikumskontrollbarriere nach einem der Ansprüche 7 bis 9, wobei ein oder mehrere Beine (22, 122) mit den Rahmenteilen verbunden sind, um dafür an einer Stelle, abgelegen von der Stützvorrichtung (11), Abstützung zu vermitteln.
11. Eine Publikumskontrollbarriere nach Anspruch 10, wobei jedes Bein (122) einstellbar an den Rahmenteilen montiert wird, um die Stellung des Beins verändern zu können, wenn die Seitenrahmenteile zur Ausdehnung von einer Seite auf die andere Seite der Stützvorrichtung (11) gedreht werden.
12. Eine Publikumskontrollbarriere nach Anspruch 10 oder 11, wobei jedes Bein (122) der Länge nach einstellbar ist.
13. Eine Publikumskontrollbarriere nach einem der Ansprüche 7 bis 12, wobei das oder jedes Längsrahmenteil (118, 121) der Länge nach einstellbar ist.
14. Eine Publikumskontrollbarriere nach einem der Ansprüche 7 bis 13, wobei die Rahmenteile aus geradlinigen Rohren bestehen, die durch Eckprofile (140, 141) miteinander verbunden sind.
15. Eine Publikumskontrollbarriere nach einem der Ansprüche 1 bis 14, wobei wenigstens ein Rahmenteil (118, 119, 120, 121) von einer ungehindert drehbaren Vorrichtung (148) umgeben ist.
16. Eine Publikumskontrollbarriere nach einem der Ansprüche 15, wobei die ungehindert drehbare Vorrichtung aus mehreren unabhängig drehbaren Hülsensegmenten (148) besteht.
17. Eine Publikumskontrollbarriere nach einem der Ansprüche 1 bis 16, wobei die flexiblen Elemente (124) durch eine mit dem Seitenrahmenteil verbundene Schiene (150), die lösbar mit dem Seitenrahmenteil verbunden ist, mit wenigsten einem der Seitenrahmenteile verbunden ist.
18. Eine Publikumskontrollbarriere nach einem der Ansprüche 1 bis 17, wobei eine Mehrzahl von Barriereabschnitten (115, 116, 117) zum Bilden einer durchgehende Barrieregruppe angeordnet sind. Dabei hat jeder Barriereabschnitt flexible Elemente (124), die zwischen den Seitenrahmenteilen (119, 120) verlaufen, wobei direkt nebeneinander liegende Barriereabschnitte ein gemeinsames Seitenrahmenteil benutzen, womit die flexiblen Elemente (124) beider Abschnitte verbunden sind.

Revendications

1. Une barrière de contrôle des foules pour restreindre le passage de personnes d'une zone d'un côté de la barrière, à une zone de l'autre côté de la barrière, la barrière comportant des moyens de support se prolongeant vers le haut à partir du sol, caractérisée en ce que des éléments latéraux espacés du châssis (19, 20; 119, 120), qui se prolongent en sens transversal par rapport à la longueur de la barrière, sont supportés dans un plan commun au-dessus du sol et que des éléments flexibles allongés (24; 124) sont raccordés aux dits éléments de châssis latéraux et sont situés entre ces éléments, avec formation d'interstices longitudinaux entre les éléments flexibles allongés.
2. Une barrière de contrôle des foules selon la revendication 1, dans laquelle les éléments flexibles (24; 124) sont substantiellement parallèles l'un à l'autre.

3. Une barrière de contrôle des foules selon la revendication 2, dans laquelle les éléments flexibles (24; 124) sont espacés d'une distance de 15 à 25 cm.
4. Une barrière de contrôle des foules selon la revendication 1, 2 ou 3, dans laquelle les éléments flexibles (24; 124) comportent des câbles en fil métallique. 5
5. Une barrière de contrôle des foules selon l'une quelconque des revendications 1 à 4, dans laquelle les éléments flexibles sont dotés de moyens de réglage de la tension au sein des éléments flexibles. 10
6. Une barrière de contrôle des foules selon l'une quelconque des revendications 1 à 5, dans laquelle les éléments de châssis latéraux (19, 20; 119, 120) sont supportés de manière à être maintenus substantiellement dans un plan horizontal. 15
7. Une barrière de contrôle des foules selon l'une quelconque des revendications 1 à 6, dans laquelle les éléments de châssis latéraux ont des premières extrémités pour raccordement aux moyens de support (11) et des secondes extrémités interconnectées par un élément de châssis longitudinal (21; 121). 20 25
8. Une barrière de contrôle des foules selon la revendication 7, dans laquelle les premières extrémités des éléments de châssis latéraux (119, 120) sont raccordés ensemble par un élément de châssis longitudinal (118). 30
9. Une barrière de contrôle des foules selon la revendication 7 ou 8, dans laquelle les extrémités internes des éléments latéraux (119, 120) sont couplées à des montures pivotantes (144) permettant de faire tourner les éléments de châssis pour qu'ils se prolongent en sens latéral de l'un ou l'autre côté du moyen de support (11). 35 40
10. Une barrière de contrôle des foules selon l'une quelconque des revendications 7 à 9, dans laquelle un ou plusieurs pieds (22; 122) sont attachés aux éléments de châssis pour les supporter en une position éloignée du moyen de support (11). 45
11. Une barrière de contrôle des foules selon la revendication 10, dans laquelle chaque pied (122) est monté de manière réglable sur les éléments de châssis pour pouvoir modifier la position du pied lorsque les éléments de châssis latéraux sont pivotés pour se prolonger d'un côté à l'autre du moyen de support (11). 50 55
12. Une barrière de contrôle des foules selon la revendication 10 ou 11, dans laquelle la longueur de chaque pied (122) est réglable.
13. Une barrière de contrôle des foules selon l'une quelconque des revendications 7 à 12, dans laquelle l'élément de châssis longitudinal (118, 121) - ou chacun de ces éléments - est réglable en longueur.
14. Une barrière de contrôle des foules selon l'une quelconque des revendications 7 à 13, dans laquelle les éléments de châssis comportent des tubes rectilignes rassemblés par des raccords en cornière (140, 141).
15. Une barrière de contrôle des foules selon l'une quelconque des revendications 1 à 14, dans laquelle au moins un élément de châssis (118, 119, 120, 121) est entouré par un moyen de rotation libre (148).
16. Une barrière de contrôle des foules selon la revendication 15, selon laquelle le moyen de rotation libre comporte plusieurs segments de gaine à rotation indépendante (148).
17. Une barrière de contrôle des foules selon l'une quelconque des revendications 1 à 16, dans laquelle les éléments flexibles (124) sont raccordés à un élément de châssis latéral au moins par un rail (150) détachable fixé à l'élément de châssis latéral.
18. Une barrière de contrôle des foules selon l'une quelconque des revendications 1 à 17, dans laquelle une pluralité de sections de barrière (115, 116, 117) est disposée de manière à constituer une barrière continue, chaque section de barrière possédant des éléments flexibles (124) qui se prolongent entre les membres de châssis latéraux (119, 120) et les sections de barrière immédiatement adjacentes qui se partagent un élément de châssis latéral commun auquel sont raccordés les éléments flexibles (124) des deux sections.

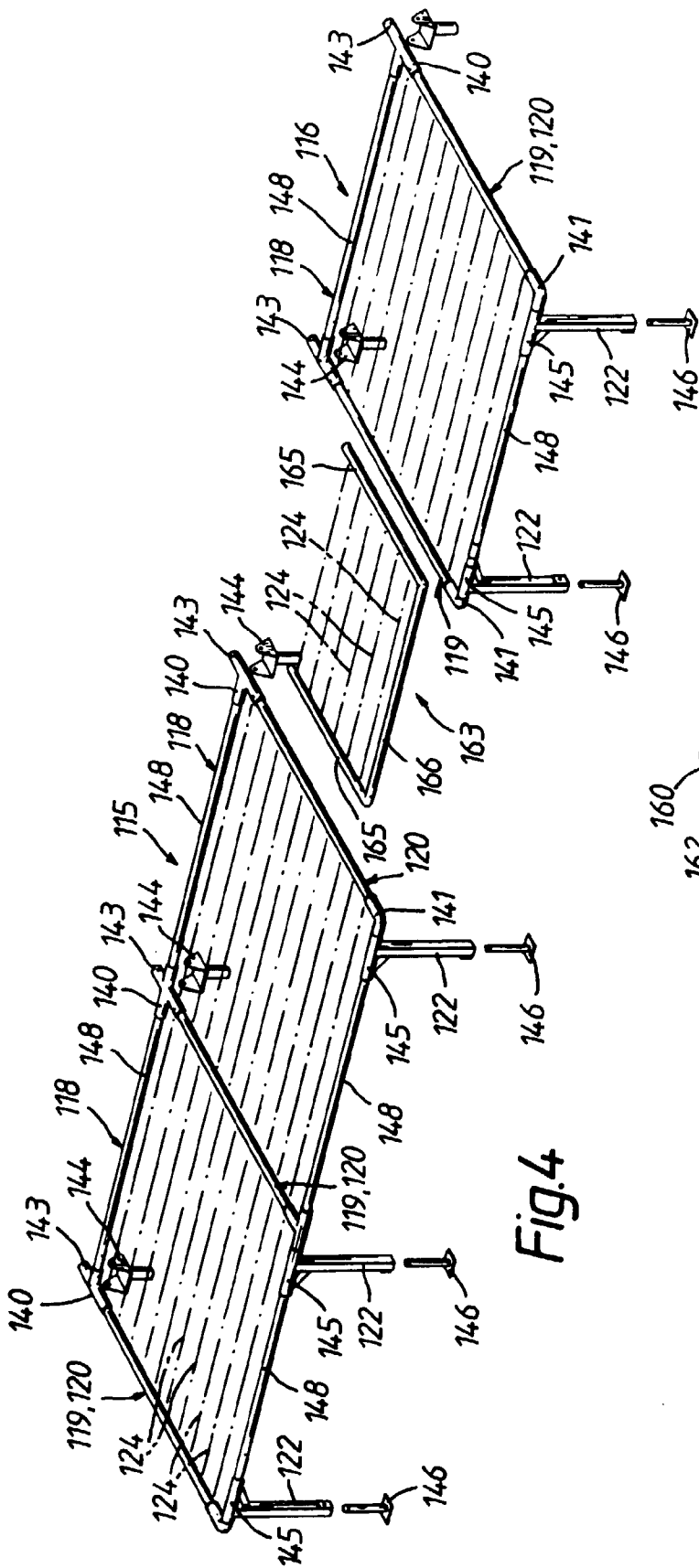

Fig. 4

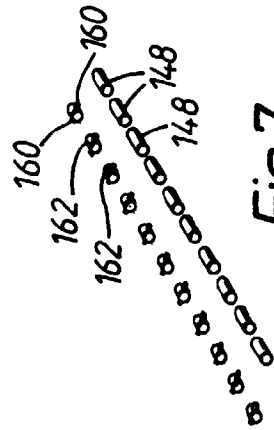

Fig. 7

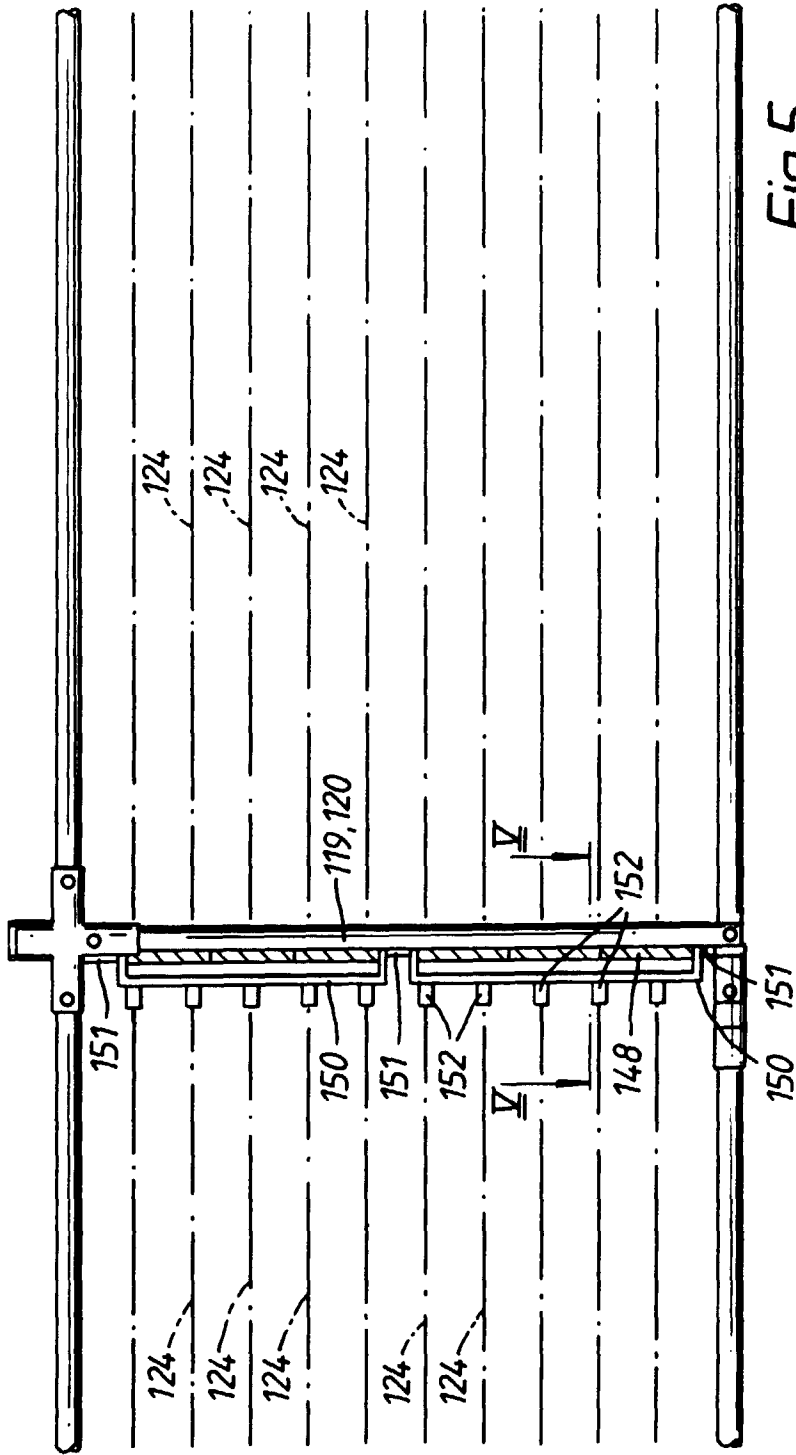

Fig. 5

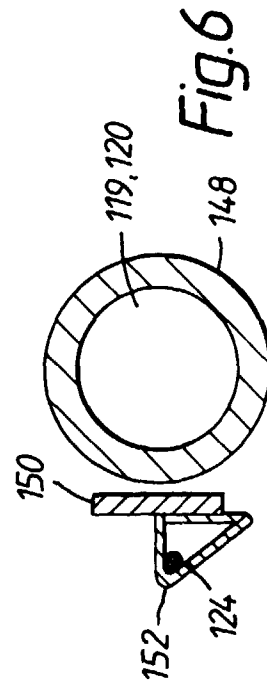

Fig. 6