

(19) World Intellectual Property Organization  
International Bureau



(43) International Publication Date  
4 June 2009 (04.06.2009)

PCT

(10) International Publication Number  
**WO 2009/070521 A2**

- (51) International Patent Classification:  
*E21B 44/00* (2006.01)
- (21) International Application Number:  
PCT/US2008/084486
- (22) International Filing Date:  
24 November 2008 (24.11.2008)
- (25) Filing Language: English
- (26) Publication Language: English
- (30) Priority Data:  
11/945,383 27 November 2007 (27.11.2007) US
- (71) Applicant (for CA only): **SCHLUMBERGER CANADA LIMITED** [CA/CA]; 525 3rd Avenue SW, Calgary Alberta, T2P0G4 (CA).
- (71) Applicant (for FR only): **SERVICES PETROLIERS SCHLUMBERGER** [FR/FR]; 42, Rue Saint-dominique, F-75007 Paris (FR).
- (71) Applicant: **PRAD RESEARCH AND DEVELOPMENT LIMITED**; Po Box 71, Craigmuir Chambers, Road Town Tortola (VG).
- (71) Applicant (for AL, AU, AZ, BG, CO, CZ, DE, DK, DZ, GR, HU, ID, IE, IL, IT, LT, MX, MY, NO, NZ, OM, PL, RO, RU, SI, SK, TM, TN, TR, TT, UA, UZ, ZA only): **SCHLUMBERGER TECHNOLOGY B.V.** [NL/NL]; Parkstraat 83-89, NL-2514 JG The Hague (NL).
- (71) Applicant: **SCHLUMBERGER HOLDINGS LIMITED**; Po Box 71, Craigmuir Chambers, Roadtown Tortola (VG).
- (72) Inventor; and
- (75) Inventor/Applicant (for US only): **ROLOVIC, Radovan** [US/US]; 6402 Kenall Creek Drive, Sugar Land, TX 77479 (US).
- (74) Agents: **FONSECA, Darla, P.** et al.; Schlumberger Technology Corporation, 200 Gillingham Lane MD 200-9, Sugar Land, TX 77478 (US).
- (81) Designated States (unless otherwise indicated, for every kind of national protection available): AE, AG, AL, AM, AO, AT, AU, AZ, BA, BB, BG, BH, BR, BW, BY, BZ, CA, CH, CN, CO, CR, CU, CZ, DE, DK, DM, DO, DZ, EC, EE, EG, ES, FI, GB, GD, GE, GH, GM, GT, HN, HR, HU, ID, IL, IN, IS, JP, KE, KG, KM, KN, KP, KR, KZ, LA, LC, LK, LR, LS, LT, LU, LY, MA, MD, ME, MG, MK, MN, MW, MX, MY, MZ, NA, NG, NI, NO, NZ, OM, PG, PH, PL, PT, RO, RS, RU, SC, SD, SE, SG, SK, SL, SM, ST, SV, SY, TJ, TM, TN, TR, TT, TZ, UA, UG, US, UZ, VC, VN, ZA, ZM, ZW.
- (84) Designated States (unless otherwise indicated, for every kind of regional protection available): ARIPO (BW, GH, GM, KE, LS, MW, MZ, NA, SD, SL, SZ, TZ, UG, ZM, ZW), Eurasian (AM, AZ, BY, KG, KZ, MD, RU, TJ, TM), European (AT, BE, BG, CH, CY, CZ, DE, DK, EE, ES, FI, FR, GB, GR, HR, HU, IE, IS, IT, LT, LU, LV, MC, MT, NL, NO, PL, PT, RO, SE, SI, SK, TR), OAPI (BF, BJ, CF, CG, CI, CM, GA, GN, GQ, GW, ML, MR, NE, SN, TD, TG).
- Published:  
— without international search report and to be republished upon receipt of that report

(54) Title: METHOD AND APPARATUS FOR HYDRAULIC STEERING OF DOWNHOLE ROTARY DRILLING SYSTEMS

(57) Abstract: A method for hydraulically controlling the direction of a drill bit or bottom hole assembly containing a drill contains lateral orifices which can be selectively opened and closed to move a portion of drilling fluid from the drill string out into a narrow gap between the lateral orifices and a lateral bore hole face or wall, which produces a lateral hydraulic force to thereby push the drill bit or bottom hole assembly in an opposite direction of the fluid flow through the lateral orifices. The apparatus for accomplishing this hydraulic steering can provide for the movement of the tip of the orifice into close proximity with the bore hole face to thereby increase the lateral hydraulic force created. This method can also be adapted to push-the-bit bore hole pads to minimize their contact with the bore hole while increasing the lateral force obtained by their engagement.

WO 2009/070521 A2

## METHOD AND APPARATUS FOR HYDRAULIC STEERING OF DOWNHOLE ROTARY DRILLING SYSTEMS

### BACKGROUND OF THE INVENTION

#### 5 Field of the Invention

The present invention relates to a directional rotary drilling method and apparatus; specifically, to a method and apparatus for moving a drill bit in a desired path by selectively adjusting a portion of drilling fluid flow through orifices located adjacent a drill bit body to apply a lateral  
10 hydraulic force and minimize contact with a bore hole with mechanical guides.

#### Related Art

All methods known to applicant use some manner of mechanical contact with the well bore to achieve the desired steering of the drilling  
15 tool, or as in the case of point-the-bit methods, the steering is achieved by offsetting the angle of the drill bit axis relative to the rest of the drill tool. Fluid pressure necessary to cause fluid flow through changing flow geometries (orifices, bends, narrow passages, conduits, etc.) commonly described as pressure loss is typically considered a negative effect of  
20 changing flow conditions because it often requires alternative design requirements. That same changing fluid flow conditions is used in the described method and apparatus to create a pressure differential between the two sides of the drilling tool and thereby achieve a desired lateral

force on the drilling tool useable for steering the tool in the given direction. There have been attempts to use changing directional fluid flows that are different than this invention and not intended to use the hydraulic pressure difference around the drilling tool for steering the tool  
5 in the preferred direction. See U. S. Patent No. 4,836,301 as an example of these types of fluid directing systems, which uses changing direction of drilling fluid flow inside the drilling tool to generate a hydrodynamic force to tilt the drill bit axis in a given direction using a point-the-bit steering method and system.

#### 10 SUMMARY OF THE INVENTION

A method for hydraulic steering of a drill bit is described which provides the steps of setting an angular direction from a longitudinal axis of a bottom hole assembly providing the drill bit; and, opening one or more lateral orifices at a selected interval to divert drilling fluid from the drill  
15 bit to provide motive hydraulic force in an angular direction opposite the angular direction required for forward progress of the drill bit toward the set direction. The method can further comprise adjusting a gap between a distal tip of the orifices and a universal joint sleeve to increase a force applicable to move the bottom hole assembly in an opposite direction.

20 This method can further provide for determining a direction for forward progress of a drill bit and directing the flow of drilling fluid from

the orifices toward a lateral face of a well bore in a manner currently practiced in directional drilling programs.

Where the point-the-bit directional drilling apparatus is used, this method can include determining a direction for forward progress of a drill bit and directing the flow of drilling fluid from the orifices to a universal joint sleeve connected to a drill bit to move the drill bit in set direction. Since the lateral hydraulic force exerted by the drilling fluid flow through the lateral orifices is a function of the distance from the distal tip of the orifice to the opposing well bore face, this method can also provide the steps of adjusting a gap between a distal tip of the orifices and a well bore face to increase a hydraulic force applicable to move the bottom hole assembly in an opposite direction, or diverting a portion of drilling fluid through a lateral pad of a rotary steerable drill bit system to direct additional force against a lateral bore hole wall.

A directional drilling bottom hole assembly used to practice the method of this invention is a bottom hole assembly having one or more lateral orifices circumferentially spaced around said bottom hole assembly, and activation valves to selectively open and close said lateral orifices to provide lateral hydraulic force on said directional drilling bottom hole assembly. The directional drilling bottom hole assembly can further provide in the bottom hole assembly a drill bit and a control unit for sensing and controlling drilling fluid flow through the lateral orifices

which control the movement of the assembly while drilling. This may be controlled either from the surface by the collection and transmission of data or using auto-steering techniques to control the direction based upon sensor input.

5           The directional drilling bottom hole assembly can be entirely located in a control unit located adjacent a drilling motor. Alternatively, the directional drilling bottom hole assembly can be adapted to a standard push-the-bit drilling assembly by providing orifices in each control pad to selectively and lateral forcefully move drilling fluid against the borehole  
10           thereby minimizing wear on the pads to achieve directional control.

          The method can additionally further comprise diverting a portion of drilling fluid through a lateral pad of a rotary steerable drill bit system to direct additional force against a lateral bore hole wall or diverting a portion of drilling fluid through one or more lateral orifices to direct the  
15           drill bit and the entire drilling BHA straight ahead along the longitudinal axis of the drilling BHA. This method can further be accomplished by using a control module/unit to measure and process drilling parameters, direction and orientation of the BHA, and using that information to control opening and closing of said lateral orifices to achieve the desired  
20           drilling direction.

          The present invention also encompasses a directional drilling bottom hole assembly comprising: a bottom hole assembly; one or more

lateral orifices circumferentially spaced around said bottom hole assembly; and, activation valves to selectively open and close said lateral orifices to provide lateral hydraulic force on said directional drilling bottom hole assembly. This embodiment can also be realized wherein the  
5 bottom hole assembly comprises a drill bit and a control unit or wherein the bottom hole assembly comprises a control unit located adjacent a drilling motor or wherein the lateral orifices are located in the drill bit body.

The apparatus of this embodiment can also provide the lateral  
10 orifices either located in the hole gauge section of the drill bit assembly, or in a separate BHA section between the drill bit and the control unit or in a section that is integral part of a control unit. Additionally, this apparatus can provide the lateral orifices inside a universal joint sleeve connected to a drill bit in a point-the-bit drilling assembly thereby  
15 permitting the hydraulic pressure to move the sleeve in the desired direction. The directional drilling bottom hole assembly can be accomplished wherein the bottom hole assembly comprises a push-the-bit drilling assembly and wherein the lateral orifices are in a control pad or wherein the bottom hole assembly comprises a mechanism for adjusting a  
20 gap between a distal tip of the lateral orifices and a well bore face or a universal joint sleeve to increase a force applicable to move the bottom hole assembly in an opposite direction.

The directional bottom hole assembly apparatus of this invention can also provide the bottom hole assembly which provides a mechanism for diverting a portion of drilling fluid through lateral orifices to direct the drill bit and the entire drilling BHA straight ahead along the longitudinal axis of the drilling BHA. Finally, the bottom hole assembly of this invention can comprise a control module/unit to measure and process drilling parameters, direction and orientation of the BHA, and uses that information to control opening and closing of said lateral orifices to achieve the desired drilling direction.

Possible benefits/advantages of the proposed drilling tool steering method and apparatus are:

- Simpler tool design - elimination of many parts, subassemblies and manufacturing processes, such as clamp plate subassemblies, kickers, pads, pistons, toroidal bore, hardfacing, nuts and bolts and other parts currently needed to achieve the push-the-bit force used for steering drilling tools.
- Elimination or minimization of wear of outer bias or steering unit parts due to fluid-only contact with the abrasive borehole.
- Substantial reduction of shock loads on the drilling bottom-hole assembly (**BHA**), because the fluid used to produce the

lateral hydraulic force would absorb much of shock loading thereby increasing **BHA** reliability.

- Substantially lower cost of new bias or steering units because of fewer parts and manufacturing processes.
- 5     • An order of magnitude reduction in service and maintenance cost because there would be no bias or steering unit parts exposed to the borehole contact (no clamp plate assemblies, kickers, pads, pistons, toroidal bores, nuts and bolts, etc. that currently need to be replaced regularly)
- 10    • Smoother borehole - no pads to scrape it.
- Faster rate of penetration and reduced drilling time - more torque is available for drilling because there is little or no mechanical contact of the bias or steering unit with the borehole to consume torque while steering the **BHA** .
- 15    • Improved reliability of drilling operations - fewer parts, as well as no moving parts on the outside of the **BHA**, no lost-in-hole parts, etc.
- Improved steering through softer formations because the lateral force used for steering is distributed as pressure only
- 20    and over a much larger borehole area.

- Improved opportunity to operate at higher temperature because of the elimination of elastomer parts

The steering of the drilling tool is achieved by applying hydraulic forces to one side of the tool, thus achieving the steering of the tool in the opposite side direction. A portion of drilling fluid (mud) is diverted through a number of lateral orifices and through a narrow gap between the tool steering section and the bore hole. Only orifices on one side of the tool are opened at a time to provide a pressure differential in the tool-borehole annulus between that and the opposite side of the tool, thus creating a side hydraulic force on the tool, which steers the tool in the opposite side direction. The pressure differential is achieved mainly by the pressure needed to push a certain amount (flow rate) of drilling fluid through the tight gap between the tool and the borehole. The pressure needed to push the fluid through the narrow tool-borehole gap is provided by the pressure difference between the inside and the outside of the drilling tool. The new approach requires a controlled flow of part of drilling mud through the steering system and out into the tool-borehole annulus through the narrow annular gap.

#### BRIEF DESCRIPTION OF THE FIGURES

Fig. 1 is a schematic diagram of the lateral orifice arrangement located in a drill bit.

Fig. 2 is a schematic diagram of the lateral orifice arrangement located in a bottom hole assembly.

Fig. 3 is a schematic diagram of an adjusting orifice body which moves the distal tip of the orifice closer to a lateral well bore face.

5 Fig. 4 is a schematic diagram of a point-the-bit rotary steering system using the hydraulic force from the orifice to move fluid against a pivot arm of the bit.

Fig. 5 is a schematic diagram of an orifice arrangement in the body of a directional drilling control pad.

10 Fig. 6 is a graph describing the expected relation between the annular gap and the lateral hydraulic force at various flow rates.

Fig. 7 is a graph describing the expected relation between the lateral flow rate and the lateral hydraulic force at various gap distances.

#### DETAILED DESCRIPTION

15 As shown in Fig. 1, a method for hydraulic steering of a down hole drilling tool without the mechanical contact of the tool steering section with the bore hole 100 is presented herein. Substantial lateral hydraulic force on a down hole tool can be achieved by the diversion of a portion of a drilling fluid that is forced to flow out on one side of the tool into the  
20 relatively small annular gap  $h$  between the lateral edge of the tool 10 and the bore hole 100. As more fully shown in the schematic drawing of Fig. 1, the pressure differential created this way around the tool/bit 50 in the

tool-borehole annulus **110** can produce a large lateral force, depending on the geometry of the flow (the gap width **h** and length, size of the lateral fluid exit hole, etc.), pressure differential between the inside of the tool and the outside of the tool, fluid properties, and other factors. The lateral  
5 force on the tool and/or the bit **50** created this way can be sufficient to provide steering of down hole drilling systems. The hydraulic lateral force can be achieved by using a design that is similar to the current bias or steering unit design, but which has a plurality of lateral orifices **40** (only one of which is shown in this cross-sectional view), instead of the  
10 current pad-piston assembly. The lateral orifice **40** exit area needs to be sufficiently close to the borehole wall or face **100** to ensure a sufficiently small gap **h** between the lateral edge of the tool body **10** where the side orifice **40** is located and the borehole **100** in order to provide enough pressure differential around the tool in the tool-borehole annulus **110**. The  
15 lateral force can also be achieved with lateral orifices **40** placed in the hole gauge **10** next to the drill bit **50** itself, where a smaller gap **h** between the tool **50** and the borehole **110** is easier to maintain during drilling (the smaller the gap, the bigger the hydraulic side force).

As the entire drilling BHA is rotated during drilling, including the  
20 lateral orifices, one or more lateral orifices are open only when they are approximately opposite to the desired change in drilling direction, while all other lateral orifices are closed until they get approximately opposite

to the desired change in drilling direction as the entire BHA rotates around its longitudinal axis. The corresponding opening and closing of the lateral orifices, or opening and closing of the drilling fluid paths to these orifices, can be achieved and controlled by using existing methods  
5 for opening and closing fluid paths to the steering pads of a traditional bias or steering unit and controlling the process with a traditional control unit that performs necessary measurements and provides control and steering functions. For example, a counter-rotating valve that rotates at the same rotational speed as the drilling BHA but in the opposite  
10 direction can be used to open and close the drilling fluid path to the lateral orifices, thus keeping the fluid flow through the lateral orifices geo-stationary, i.e. in the same relative direction/orientation to the earth, while the rest of the drilling BHA rotates relative to the earth. The drilling fluid flow through the lateral orifices is kept geo-stationary in the  
15 lateral direction that is opposite to the desired change in drilling direction.

The desired opening and closing of the lateral orifices or the fluid paths to these orifices also can be achieved by other means, such as a piston or valve mechanism controlled from the control unit that measures the relative BHA position and orientation in real time, or by other means.

20 The described methods and mechanisms can also be used to direct the drilling BHA to drill straight ahead in a straight line along its longitudinal axis. For example, the rotary valve described above can be

used to direct the drilling fluid flow to one or more lateral orifices to achieve the desired lateral hydraulic force and the corresponding drill bit movement in the opposite direction. When the rotary valve is not kept geo-stationary but instead it is rotated fully or partially with the rest of the BHA, or partially counter rotated relative to the BHA, the drilling fluid is effectively directed to the lateral orifices while they are in various orientations to the earth, thus applying the lateral hydraulic force in all directions around the bore hole and thus directing the drilling BHA straight ahead along its longitudinal axis. Another way of directing the BHA to drill straight ahead is to open all the lateral orifices at the same time, or to close all lateral orifices while drilling straight and switch back to the steering mode when the BHA starts to deviate from the straight path.

In another embodiment as shown in Fig. 4, the proposed method can be used to achieve steering of a drilling tool **51** by discharging a portion of the drilling fluid into the tool-borehole annulus on one side of the drilling tool between two integral parts of the down hole tool itself, for example, between the tool inner body **52** and an outer sleeve **53** connected together with a universal joint **UJ**, where the outer sleeve **53** is connected to the bit shaft **54**, and where an angular offset of the sleeve **53** and the bit axis relative to the tool inner body axis, which provides the desired steering of the bit, is achieved by a similar hydraulic force. By

opening the lateral orifices only when they are opposite to the desired change in the drilling direction as the BHA rotates, and by using one of the methods described above for controlling the opening and closing of the lateral orifices, the outer sleeve 53 and the drill bit axis are kept at an angular offset relative to the rest of the BHA, which steers the tool in the direction of the angular offset that is kept geo-stationary in the desired drilling direction.

Current directional drilling systems use a down hole mud motor with a bend sub or a rotary steerable system (RSS) with a steering section to create a 2-D or a 3-D well bore trajectory. RSS systems have many advantages over mud motor systems and are used for most drilling applications today. The current RSS systems use push-the-bit or point-the-bit approaches to achieve the desired steering of the drilling tool.

Most of the today's drilling market is covered by systems using the push the bit technology, which uses mechanical pads 200, an example of which is partially shown in Fig. 5, that extend radially from the drilling tool and push against the borehole 100 to achieve a side force on the tool that in turn forces the bit to drill in the same direction of the side force acting on the tool. The principal problem with these pad systems is high wear that results from contacts with the borehole 100, which results in a high manufacturing and repair cost and therefore an overall higher cost of

service delivery. The novel approach proposed herein minimizes mechanical contacts with the bore hole for steering purposes.

Pressure drop test data show that a large pressure differential and thus a large lateral force could be achieved with the currently used pressure difference between the inside and the outside of the drilling tool and with a fraction of the current overall flow rate of the drilling fluid. Figs. 6 and 7 summarize this relationship.

Steering of the drilling tool or drill bit can be achieved by applying hydraulic forces to one side of the tool, thus achieving the steering of the tool in the opposite direction. The concept of the proposed invention can be explained by using Fig. 2. A portion of drilling fluid (mud) is diverted through a lateral orifice ( $Q_s$ ) and into a narrow gap ( $h$ ) between the tool steering section 11 and the borehole 100. Only orifices 40 on one side of the tool are opened for the lateral fluid flow ( $Q_s$ ) at a time to provide a pressure differential between that and the opposite side of the tool ( $p_1 - p_2$ ), thus creating a lateral hydraulic force on the tool and the bit ( $F_s$ ), which steers the tool and the bit in the opposite direction of the side flow  $Q_s$ . The pressure differential is achieved principally by the pressure required to push a certain amount of drilling fluid (at fluid flow rate -  $Q_s$ ) through the tight gap between the tool and the borehole (dimension  $h$  in Fig. 2). The pressure needed to push the fluid through the narrow tool-

borehole gap  $h$  is provided by the pressure difference between the inside  $p_0$  and the outside of the drilling tool  $p_2$ .

In another embodiment, the lateral discharge of portion of the drilling fluid  $Q_s$  can be forced into an even tighter annular gap  $h$  between  
5 the bit hole gauge section **10** and the bore hole **100** on an adjacent lateral side of the drill bit **50** as shown in Fig. 1. In this manner, a higher lateral hydraulic force  $F_s$  for steering the bit can be achieved with less fluid loss. Also, this system may be less complex because it would eliminate the need for an entirely separate steering section/module of the downhole  
10 tool. For example, the flow control mechanism, e.g. a rotary valve, can be part of the control unit, and the lateral orifices used for steering can be part of the drill bit assembly. Traditionally, there is a separate steering section/module, e.g. a bias unit, between the drill bit and the control unit.

If the annular gap ( $h$ ) between the tool **50** in Fig. 1 or **11** in Fig. 2 and the  
15 borehole **100** is too large or may change significantly during drilling, a modified orifice body, an example of which is shown in Fig. 3, can be used to provide a self-adjusting tight annular gap ( $h$ ). The fluid pressure on the inner end of the adjustable adapter  $p_0$  would push the adapter **300** radially outwards, reducing the annular gap ( $h$ ) in the process. When the  
20 annular gap  $h$  is small enough to produce fluid pressure on the outer end of the adapter **300** (in the gap  $h$ ) which produces an inward force on the adaptor end that is equal to the outward force on the adaptor from the

inner fluid pressure, the adaptor reaches an equilibrium state resulting in an annular gap ( $h$ ) that can be smaller than those described in the previous examples. The size of the adjustable gap ( $h$ ) mainly depends on the geometry of the adaptor, geometry of the fluid flow, and the pressure difference between the inside and the outside of the drilling tool. Thus, a desired, self-adjusting annular gap  $h$  can be achieved and maintained by carefully specifying and controlling these parameters. When the adapter 300 is not used for steering purposes, and to prevent it from protruding radially out of the BHA too much, a spring, or an elastomer or other means can be used to keep the adapter in its inner-most position inside the BHA, example of which is shown in Fig. 3. In another embodiment, the proposed method can be used to achieve steering of a drilling tool by discharging a portion of the drilling fluid on one side of the drilling tool between two integral parts of the down hole tool itself, for example, between the tool inner body 52 and an outer sleeve 53 connected together with a universal joint (UJ), as shown in Fig. 4, where the outer sleeve 53 is connected to the bit shaft 54, and where an angular offset of the sleeve and the bit axis relative to the tool inner body axis, which provides the desired steering of the bit, is achieved by a similar hydraulic force. The particular design concept in Fig. 4 can be optimized to further restrict the exit of the fluid between the sleeve and the tool inner body to increase the pressure ( $p_1$ ) between the two parts, thus increasing the differential

pressure ( $p_1 - p_2$ ) and increasing the hydraulic lateral force  $F_s$ , that is used for steering.

The proposed method also can be used with the existing drilling tool designs to minimize the abrasion wear and tool shocks and vibrations as shown in Fig. 5. A small amount of drilling fluid can be discharged under pressure through the pad 200 at the pad-bore hole interface 210 to produce a hydraulic force  $F_s$  on the pad and reduce or eliminate the mechanical contact between the pad 200 and the bore hole 100. Because the gap between the active pad and the bore hole is very small or basically non-existent while the pad is pushing against the bore hole, only a small amount of drilling fluid would need to be discharged to achieve a relatively large hydraulic lateral force between the pad 200 and the borehole 100 and, therefore, minimize or eliminate the mechanical contact between the pad 200 and the borehole 100.

Estimates of the lateral hydraulic forces associated with the steering method described herein are shown in Fig. 6 and Fig. 7. The pressure in the annular gap  $h$  between the tool and the bore hole used to calculate these lateral hydraulic forces was estimated based on measured pressure drop data when water was pumped through a down hole nozzle with an equivalent overall fluid discharge area (total area of all nozzle orifices). The pressure distribution in the annular gap was assumed to correspond to the measured pressure drop through the down hole nozzle

for the same total flow area, i.e. the fluid flow in the annular gap  $h$  requires the same pressure to achieve the same flow rate as the fluid flow through the nozzle for the same flow area (total nozzle orifice area). Since the flow area in the annular gap  $h$  progressively increases with distance from the lateral orifice, the pressure in the gap was estimated at various radial distances from the lateral orifice and the lateral force was calculated as the sum of products of each discrete pressure and the corresponding tool area. Although these pressure-force estimates are based on test data from a different flow system, they provide an approximation of the pressure distribution in the annular gap  $h$  and the lateral hydraulic force  $F_L$ , on the drilling system under consideration.

As can be seen from Fig. 6 and Fig. 7, lateral hydraulic forces higher than the pad forces of a comparable commercial drilling system, shown as Standard Pad system in Fig. 6 and Fig. 7, can be achieved for many practical flow rates and annular gaps, which depend on the hole size drilled, among other factors. For the examples in Fig. 6 and Fig. 7, practical flow rates through the lateral orifices (lateral flow rates) can be on the order of 100 gpm and the practical annular gap  $h$  can be on the order of 2 mm, but other lateral flow rates and annular gaps can be practical as well. For example, a tighter annular gap  $h$  can be made practical with the method and mechanism shown in Fig. 3, thus

increasing the lateral hydraulic force even further, and reducing the required lateral flow rate for effective steering of the drilling BHA.

Additionally, to achieve a higher pressure in the annular gap  $h$  and, consequently, higher lateral force  $F_s$  for hydraulic steering of the drilling tool, the geometry of the annular flow can be changed so that a higher pressure drop is achieved in the annular gap both near and away from the lateral orifice, for the same nominal annular gap  $h$  and the same lateral fluid flow rate  $Q_s$ . For example, the lateral flow can be discharged in the localized annular gap at multiple points in different directions to create a higher pressure drop and a higher pressure in a larger annular gap area, producing a larger lateral force (e.g. multiple lateral flows in the same annular gap would flow against each other, thus possibly creating a higher pressure drop before the fluid exits the annular gap area). Other ways, for example without limitation include changing the flow and tool geometries, fluid properties, and pressure differentials can be substituted for a more optimized hydraulic lateral forces on the drilling tool thereby providing adequate steering with a minimum disruption to the fluid flow through the drill bit.

Numerous embodiments and alternatives thereof have been disclosed. While the above disclosure includes the best mode belief in carrying out the invention as contemplated by the named inventors, not all possible alternatives have been disclosed. For that reason, the scope

and limitation of the present invention is not to be restricted to the above disclosure, but is instead to be defined and construed by the appended claims.

## CLAIMS

What I claim is:

- 5 1. A method for hydraulic steering of a drill bit comprising:  
setting an angular direction from a longitudinal axis of a bottom  
hole assembly providing the drill bit; and,  
opening one or more lateral orifices at a selected interval to divert  
drilling fluid from the drill bit to provide motive hydraulic force  
10 in an angular direction opposite the angular direction required  
for forward progress of the drill bit toward the set direction.
2. The method of claim 1 further comprising determining a direction  
for forward progress of a drill bit and directing the flow of drilling  
fluid from the orifices toward a lateral face of a well bore.
- 15 3. The method of claim 1 further comprising determining a direction  
for forward progress of a drill bit and directing the flow of drilling  
fluid from the orifices to a universal joint sleeve connected to a  
drill bit to move the drill bit in set direction.
4. The method of claim 1 further comprising adjusting a gap between  
20 a distal tip of the orifices and a well bore face to increase a force  
applicable to move the bottom hole assembly in an opposite  
direction.

5. The method of claim 1 further comprising adjusting a gap between a distal tip of the orifices and a universal joint sleeve to increase a force applicable to move the bottom hole assembly in an opposite direction.
- 5 6. The method of claim 1 further comprising diverting a portion of drilling fluid through a lateral pad of a rotary steerable drill bit system to direct additional force against a lateral bore hole wall.
7. The method of claim 1 further comprising diverting a portion of drilling fluid through one or more lateral orifices to direct the drill  
10 bit and the entire drilling BHA straight ahead along the longitudinal axis of the drilling BHA.
8. The method of claim 1 further comprising using a control module/unit to measure and process drilling parameters, direction and orientation of the BHA, and using that information to control  
15 opening and closing of said lateral orifices to achieve the desired drilling direction.
9. A directional drilling bottom hole assembly comprising:  
a bottom hole assembly;  
one or more lateral orifices circumferentially spaced around said  
20 bottom hole assembly; and,

activation valves to selectively open and close said lateral orifices to provide lateral hydraulic force on said directional drilling bottom hole assembly.

10. The directional drilling bottom hole assembly of claim 9 wherein  
5 the bottom hole assembly comprises a drill bit and a control unit.
11. The directional drilling bottom hole assembly of claim 9 wherein the bottom hole assembly comprises a control unit located adjacent a drilling motor.
12. The directional drilling bottom hole assembly of claim 9 wherein  
10 the lateral orifices are located in the drill bit body.
13. The directional drilling bottom hole assembly of claim 9 wherein the lateral orifices are located in the hole gauge section of the drill bit assembly.
14. The directional drilling bottom hole assembly of claim 9 wherein  
15 the lateral orifices are located in a separate BHA section between the drill bit and the control unit.
15. The directional drilling bottom hole assembly of claim 9 wherein the lateral orifices are located in a section that is integral part of a control unit.
- 20 16. The directional drilling bottom hole assembly of claim 9 wherein the lateral orifices are located inside a universal joint sleeve connected to a drill bit in a point-the-bit drilling assembly.

17. The directional drilling bottom hole assembly of claim 9 wherein the bottom hole assembly comprises a push-the-bit drilling assembly and wherein the lateral orifices are in a control pad.
18. The directional bottom hole assembly of claim 9 wherein the  
5 bottom hole assembly comprises a mechanism for adjusting a gap between a distal tip of the lateral orifices and a well bore face or a universal joint sleeve to increase a force applicable to move the bottom hole assembly in an opposite direction.
19. The directional bottom hole assembly of claim 9 wherein the  
10 bottom hole assembly comprises a mechanism for diverting a portion of drilling fluid through lateral orifices to direct the drill bit and the entire drilling BHA straight ahead along the longitudinal axis of the drilling BHA.
20. The directional bottom hole assembly of claim 9 wherein the  
15 bottom hole assembly comprises a control module/unit to measure and process drilling parameters, direction and orientation of the BHA, and uses that information to control opening and closing of said lateral orifices to achieve the desired drilling direction.

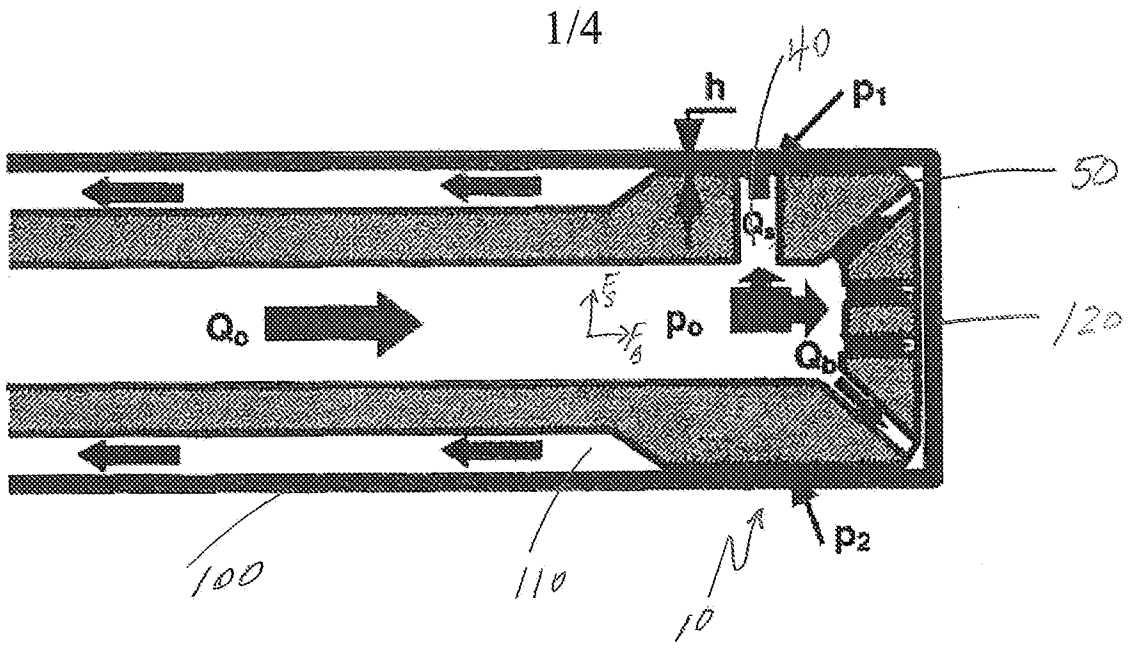

FIG. 1

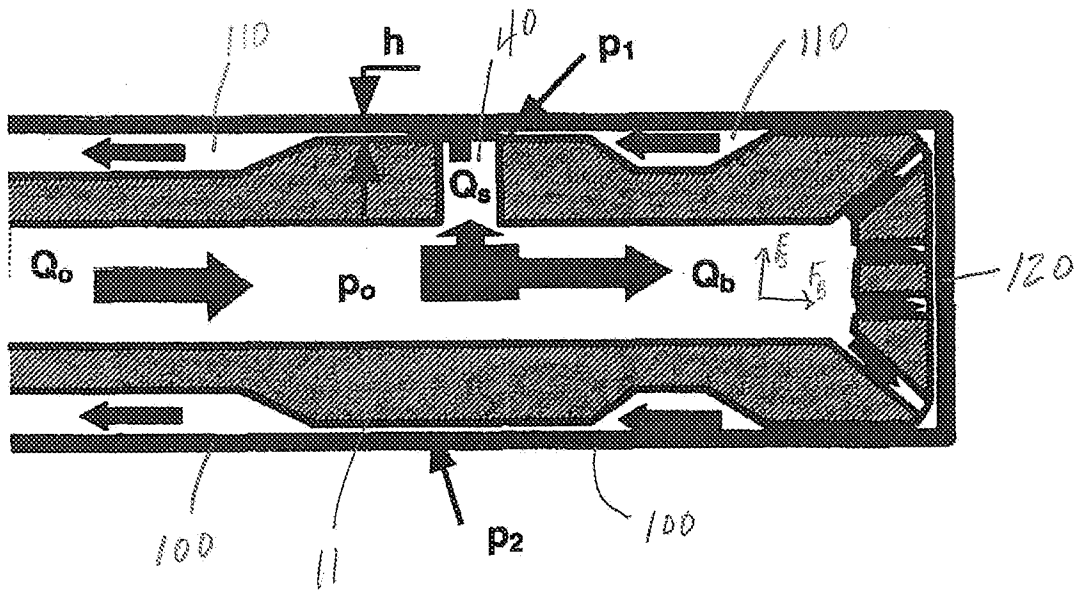

FIG. 2

2/4

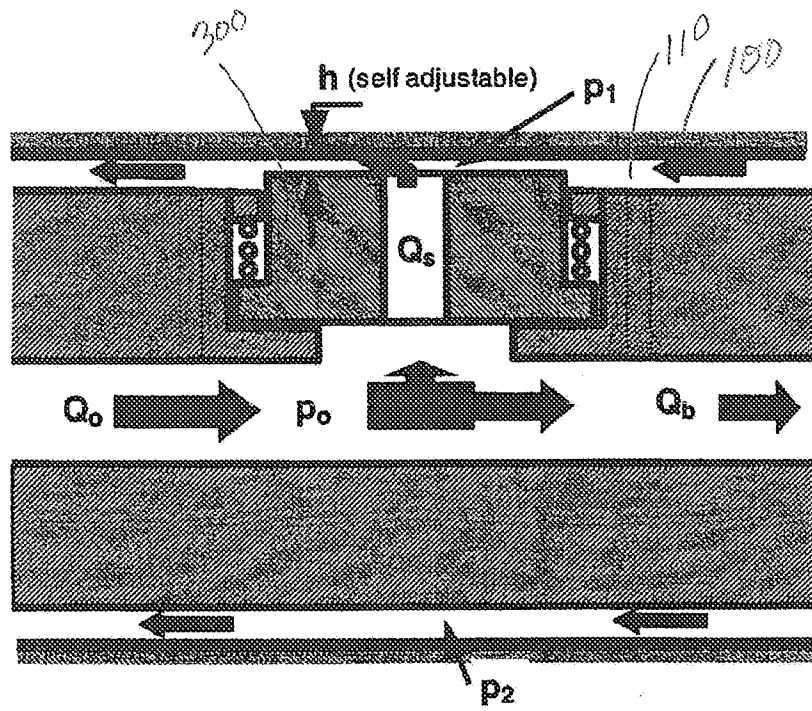

FIG. 3

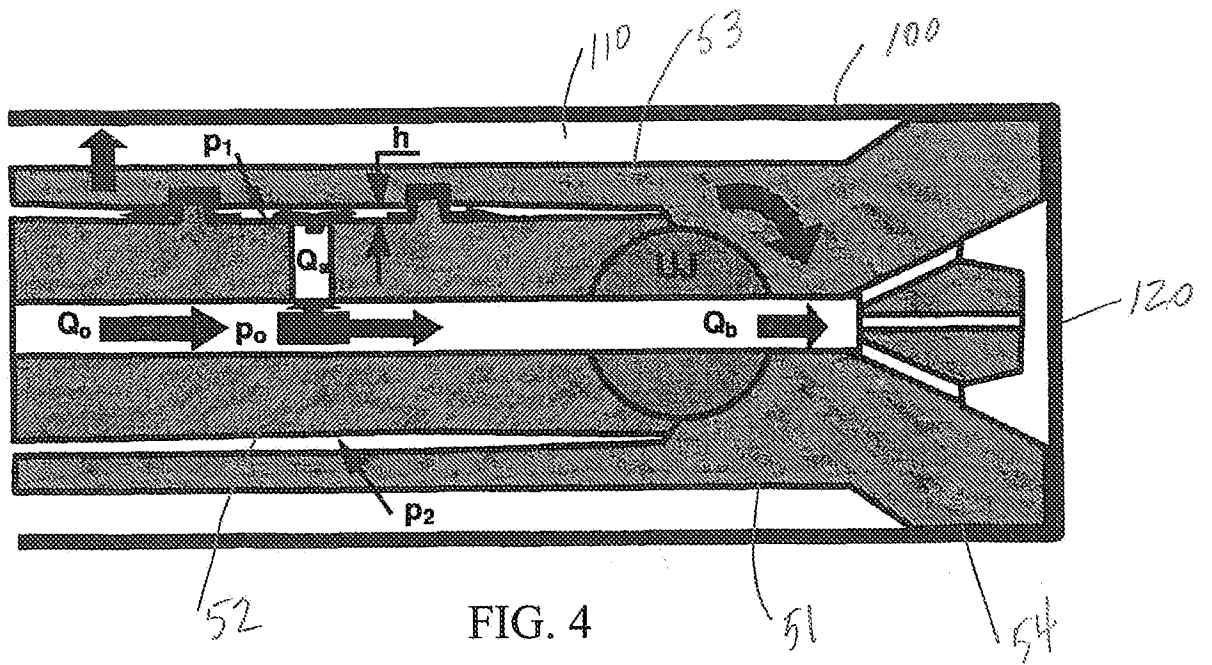

FIG. 4

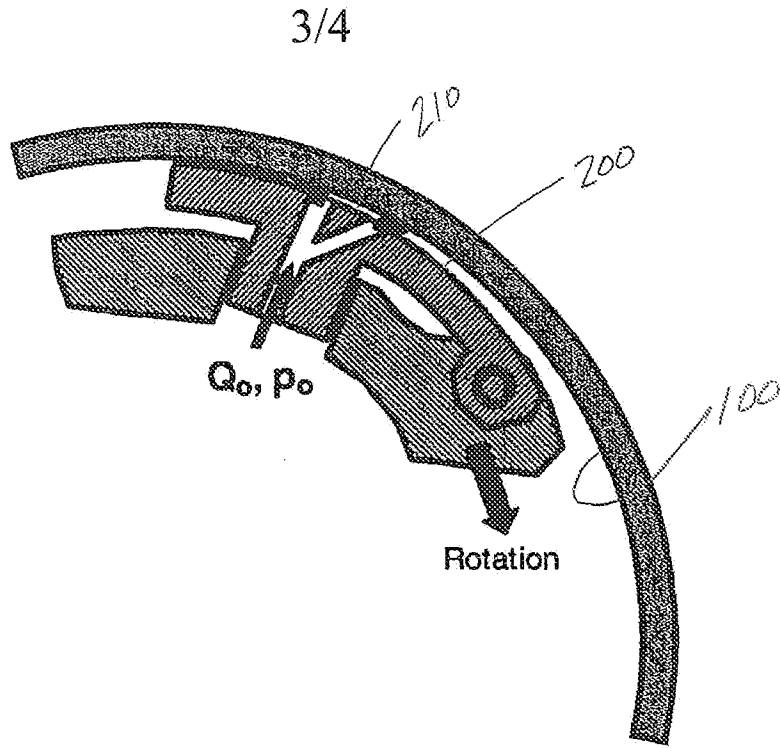

FIG. 5

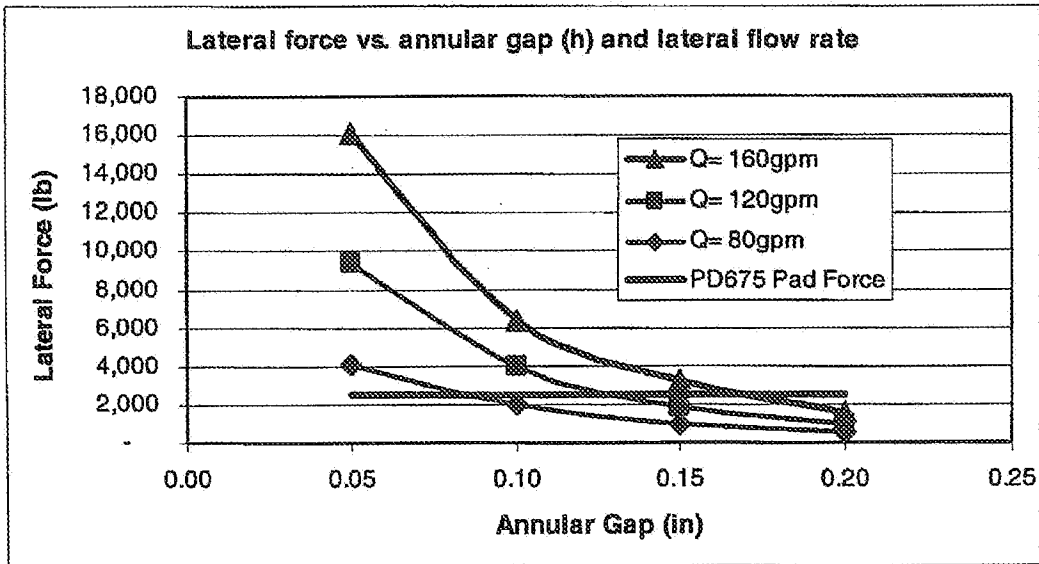

FIG. 6

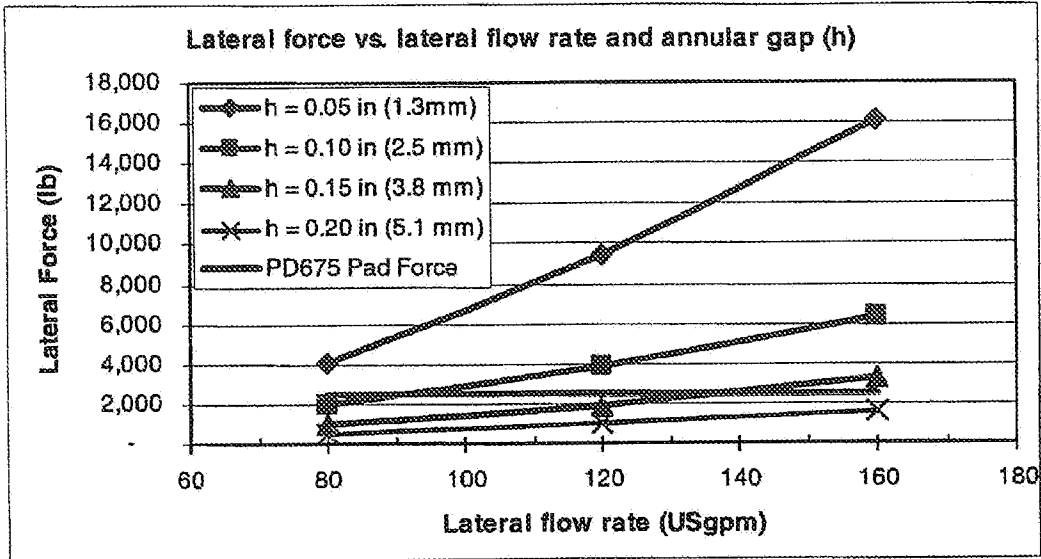

FIG. 7