

Cope & Maxwell,

Screw-Threading Machine.

N^o 64,495.

Patented May 7, 1867.

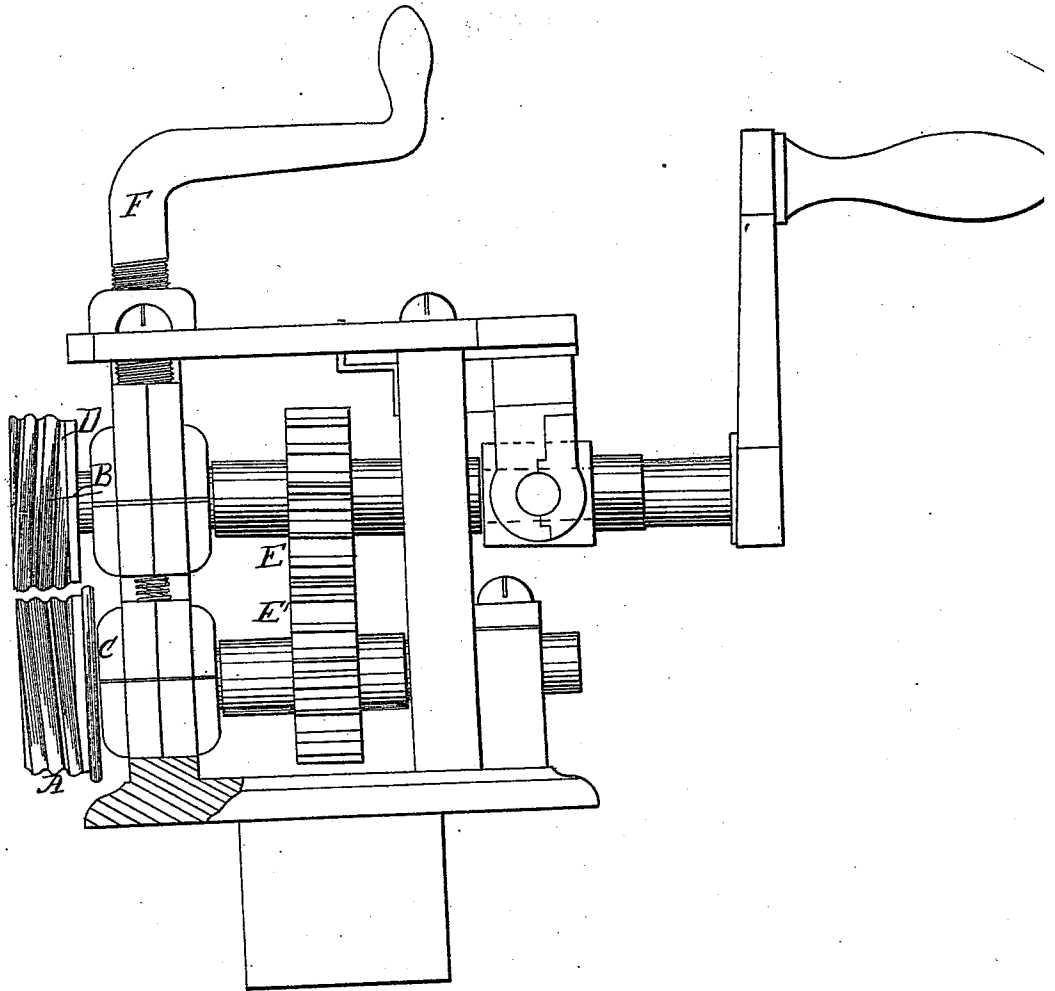

Witnesses.

*Nathan Marchant
Jas. H. Power*

Inventors

*Orza Cope
James R. Maxwell*

United States Patent Office.

EZRA COPE AND JAMES R. MAXWELL, OF CINCINNATI, OHIO.

Letters Patent No. 64,495, dated May 7, 1867.

IMPROVED SCREW-SWAGING MACHINE.

The Schedule referred to in these Letters Patent and making part of the same.

TO ALL WHOM IT MAY CONCERN:

Be it known that we, EZRA COPE and JAMES R. MAXWELL, of Cincinnati, in the county of Hamilton, and State of Ohio, have invented a new and improved Mode of Forming Screws on Sheet-Metal Tubes or Rings; and we do hereby declare that the following is a full, clear, and exact description thereof, reference being had to the accompanying drawing, and to the letters of reference marked thereon.

The nature of our invention consists in constructing two rolls or swages, upon each of which is formed a screw, one right and the other left handed, of equal pitch and size, and so geared together that the space of one roll is opposite the thread or raised portion of the other continuously; also, in having a blank space upon each roll when used for swaging rings, upon which caps are to fit.

To enable others skilled in the art to make and use our invention we will proceed to describe its construction and operation.

We construct our rolls of such metal as is best suited to the purpose for which they are to be used, and should be made of the same diameter as the tube or ring to be operated upon. The thread should be of the ogee form, as shown in the drawing. This form of thread is less straining upon the metal, and is more readily formed. The roll A, upon which the tube or ring is placed, has a right-hand thread, while the roll B is left hand, and bears upon the outside of the tube or ring, and forces the metal into the space in the lower roll. The thread does not cover the whole face of the rolls in all cases, but has blank parts C D, when desired, to form rings upon which lids or ends are to be placed, (as for fruit-jar tops or caps,) while for tubes the blank spaces are not needed. By the use of the right and left-hand screw-rolls A B, which are geared together, we get a continuous motion of the rolls, and the metal operated upon does not change its position while being operated upon in relation to the rolls. By gearing the rolls together they cannot change in position to each other, so the thread of one meshes into the space of the other continuously as they revolve. The main parts of the machine, shown by the drawing, are in common use by all tanners; therefore the gear E E' and screw F are parts pertaining to all swaging machines. The rolls or swages A B only are new.

We operate these rolls or swages in the following manner: The tube or ring to be operated upon is formed of the diameter desired to fit the roll A as near as possible, so that it may be held square and firm. Then revolve the rolls, and, at the same time, screwing the roll B gently down by the screw F until the proper depth of thread is obtained, then release the screw F, so that roll B will rise and release the work. Now grasp the ring firmly, and revolve the machine in the opposite direction, which will screw the ring off finished.

We are aware that two swaging-rolls arranged and operating in a manner similar to this we have described for forming a series of parallel ridges and depressions are not new, and we therefore do not claim such device as of our invention; but what we do claim, and desire to secure by Letters Patent, is—

1. Constructing said rolls with right and left-hand screws, respectively, and arranging them so that the threads upon one shall bend the metal into the grooves of the other, all substantially as above set forth.
2. Also, in combination with the subject-matter of the first claim, we claim leaving a portion of the surface of the rolls plain or blank, in the manner and for the purpose described.

EZRA COPE,
JAMES R. MAXWELL.

Witnesses:

N. MARCHANT,
JAS. C. BOWEN.