

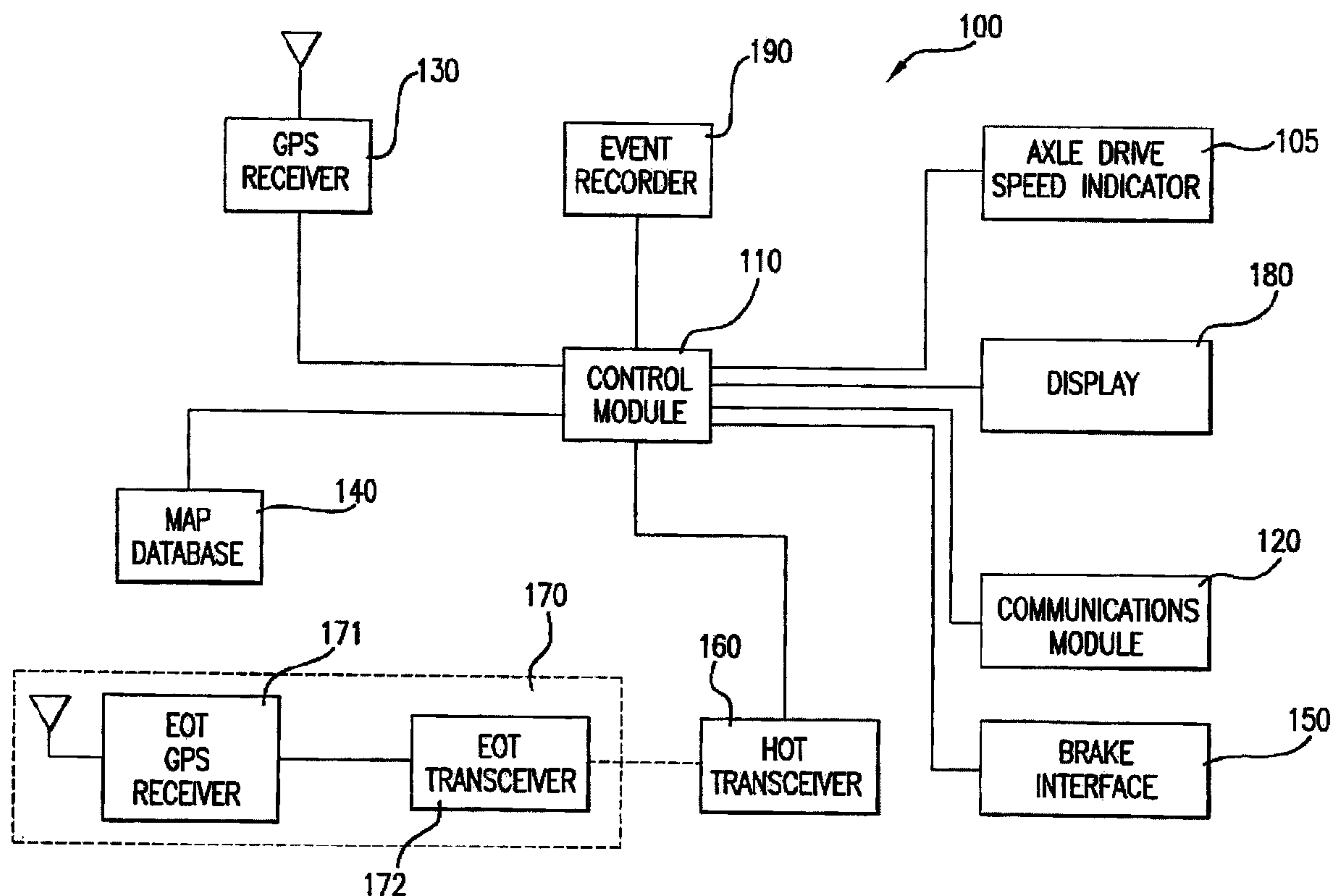

(86) Date de dépôt PCT/PCT Filing Date: 2003/07/02  
 (87) Date publication PCT/PCT Publication Date: 2004/01/15  
 (45) Date de délivrance/Issue Date: 2012/09/04  
 (85) Entrée phase nationale/National Entry: 2004/12/21  
 (86) N° demande PCT/PCT Application No.: US 2003/020745  
 (87) N° publication PCT/PCT Publication No.: 2004/005104  
 (30) Priorité/Priority: 2002/07/02 (US10/186,426)

(51) Cl.Int./Int.Cl. *G09D 1/00* (2006.01),  
*B61L 15/00* (2006.01)  
 (72) Inventeurs/Inventors:  
KANE, MARK EDWARD, US;  
SHOCKLEY, JAMES FRANCIS, US;  
HICKENLOOPER, HARRISON THOMAS, US  
 (73) Propriétaire/Owner:  
INVENSYS RAIL CORPORATION, US  
 (74) Agent: NORTON ROSE CANADA  
S.E.N.C.R.L.,S.R.L./LLP

(54) Titre : SYSTEME DE COMMANDE DE TRAIN ET PROCEDE POUR COMMANDER UN OU PLUSIEURS TRAINS  
 (54) Title: TRAIN CONTROL SYSTEM AND METHOD OF CONTROLLING A TRAIN OR TRAINS



(57) Abrégé/Abstract:

A train control system includes positioning system (171) at the end of the train and at the front of the train, allowing the conductor or engineer to unambiguously determine that no cars of the train have become detached. The positioning system (171) at the end of the train is also used to verify that the entire train has cleared a block. This information can be relayed to a dispatcher, thereby eliminating the need for trackside sensing equipment. A control unit prevents the train from moving without an authorization that includes the train's current position.



(12) INTERNATIONAL APPLICATION PUBLISHED UNDER THE PATENT COOPERATION TREATY (PCT)

(19) World Intellectual Property  
Organization  
International Bureau



(43) International Publication Date  
15 January 2004 (15.01.2004)

PCT

(10) International Publication Number  
**WO 2004/005104 A3**

- (51) International Patent Classification<sup>7</sup>: **G09D 1/00**
- (21) International Application Number:  
PCT/US2003/020745
- (22) International Filing Date: 2 July 2003 (02.07.2003)
- (25) Filing Language: English
- (26) Publication Language: English
- (30) Priority Data:  
10/186,426 2 July 2002 (02.07.2002) US
- (71) Applicant: **QUANTUM ENGINEERING, INC.**  
[US/US]; 352 Stowe Avenue, Orange Park, FL 32703 (US).
- (72) Inventors: **KANE, Mark, Edward**; 2653 Holly Point Drive, Orange Park, FL 32073 (US). **SHOCKLEY, James, Francis**; 3011 Doctors Lake Drive, Orange Park, FL 32073 (US). **HICKENLOOPER, Harrison, Thomas**; Route 3, Box 1830, Palatka, FL 32177 (US).
- (74) Agents: **KELBER, Steven, B.** et al.; Piper Rudnick LLP, 1200 Nineteenth Street, N.W., Washington, DC 20036 (US).
- (81) Designated States (*national*): AE, AG, AL, AM, AT, AU, AZ, BA, BB, BG, BR, BY, BZ, CA, CH, CN, CO, CR, CU, CZ, DE, DK, DM, DZ, EC, EE, ES, FI, GB, GD, GE, GH, GM, HR, HU, ID, IL, IN, IS, JP, KE, KG, KP, KR, KZ, LC, LK, LR, LS, LT, LU, LV, MA, MD, MG, MK, MN, MW, MX, MZ, NI, NO, NZ, OM, PG, PH, PL, PT, RO, RU, SC, SD, SE, SG, SK, SL, SY, TJ, TM, TN, TR, TT, TZ, UA, UG, UZ, VC, VN, YU, ZA, ZM, ZW.
- (84) Designated States (*regional*): ARIPO patent (GH, GM, KE, LS, MW, MZ, SD, SL, SZ, TZ, UG, ZM, ZW), Eurasian patent (AM, AZ, BY, KG, KZ, MD, RU, TJ, TM), European patent (AT, BE, BG, CH, CY, CZ, DE, DK, EE, ES, FI, FR, GB, GR, HU, IE, IT, LU, MC, NL, PT, RO, SE, SI, SK, TR), OAPI patent (BF, BJ, CF, CG, CI, CM, GA, GN, GQ, GW, ML, MR, NE, SN, TD, TG).
- Published:**  
— with international search report
- (88) Date of publication of the international search report:  
1 July 2004
- For two-letter codes and other abbreviations, refer to the "Guidance Notes on Codes and Abbreviations" appearing at the beginning of each regular issue of the PCT Gazette.

(54) Title: TRAIN CONTROL SYSTEM AND METHOD

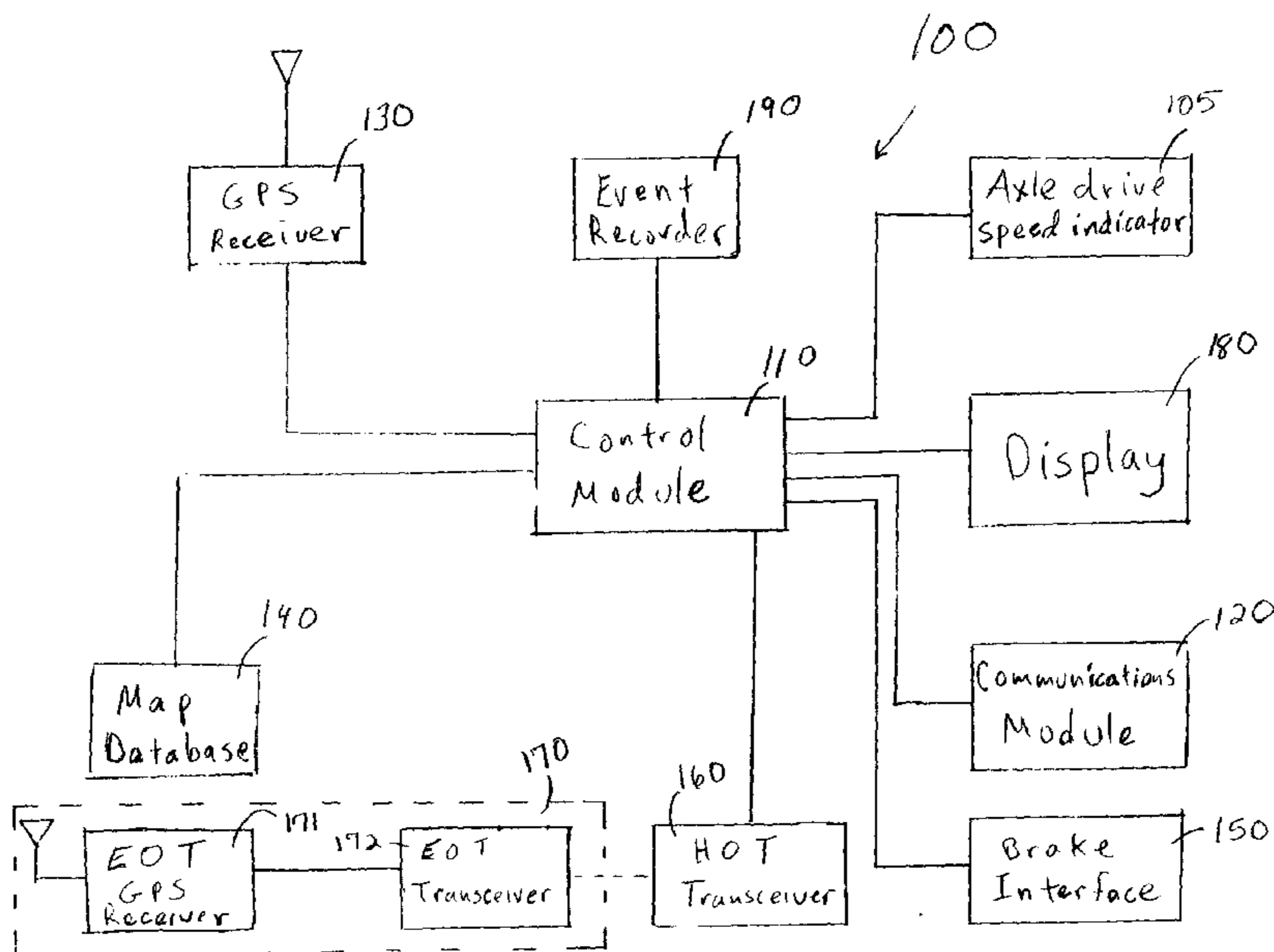

(57) Abstract: A train control system includes positioning system (171) at the end of the train and at the front of the train, allowing the conductor or engineer to unambiguously determine that no cars of the train have become detached. The positioning system (171) at the end of the train is also used to verify that the entire train has cleared a block. This information can be relayed to a dispatcher, thereby eliminating the need for trackside sensing equipment. A control unit prevents the train from moving without an authorization that includes the train's current position.

WO 2004/005104 A3

**TITLE OF THE INVENTION****TRAIN CONTROL SYSTEM AND  
METHOD OF CONTROLLING A TRAIN OR TRAINS****BACKGROUND OF THE INVENTION****5     Field of the Invention**

The invention relates to railroads generally, and more particularly to automatic control of trains.

**Discussion of the Background**

10     Controlling the movement of trains in a modern environment both in a train yard and on the main line is a complex process. Collisions with other trains must be avoided and regulations in areas such as grade crossings must be complied with. The pressure to increase the performance of rail systems, in terms of speed, reliability and safety, has led to many proposals to automate various aspects of train operation.

15     One traditional method for controlling trains is known as track warrant control. This method is most often used in areas of dark territory (track that does not include a wayside signaling system). Simply put, a track warrant is permission to occupy a given section of track, i.e., a block. The traditional track warrant control method, which is defined in the General Code of Operational Rules,  
20     involves "written" verbal orders which may be modified or rescinded by communication over a radio with a dispatcher. In the system, a dispatcher gives a train or a maintenance crew verbal authority (a warrant) to occupy a portion of



main line track between named locations (e.g., mile markers, switches, stations, or other points). In addition to specifying certain track sections, track warrants can specify speed limits, direction, time limits, and whether to clear the main line (e.g., by entering a secondary track such as a siding) and/or any other section of track

5 (sidings, yards secondary track, etc...). There is a complicated and time consuming procedure by which track warrants are issued which involves the train conductor or engineer reading back the warrant to the dispatcher before the warrant goes into effect. One important disadvantage to this system is that it relies on human beings, both to communicate the warrant properly and to ensure that the warrant is

10 complied with. The system is thus subject to errors which can be disastrous.

Some systems, such as the Track Warrant Control System sold by RDC (Railroad Development Corporation), have automated some of the track warrant control method, such as by sending the warrant to the train via a computer system. Another system, Automatic Block Signaling (ABS), provides for automated

15 wayside signaling of block status and authority to enter or occupy a block. In this system, track warrants may overlap and the conductor or engineer uses the automatic wayside signals to determine when and how to proceed in a given block. Again, human beings are involved and errors are possible.

In another system known as Cab Signal, a display is provided in the cab for

20 the engineer/conductor. This display basically displays wayside signals to the engineer/conductor and forces the engineer/conductor to acknowledge signals that are more restrictive than the current signal. However, the Cab Signal system does not force the engineer/conductor to obey the more restrictive signal. Thus, an engineer/conductor may be forced to acknowledge a signal that reduces the

maximum speed from 20 m.p.h. to 10 m.p.h., but the train will not be forced to slow to 10 m.p.h.; rather, the engineer/conductor must take action to slow the train. Once again, the potential for error exists.

A second traditional system known as Centralized Traffic Control (CTC) allows a dispatcher to control movement of trains by controlling track switches and wayside signals from a central dispatch office. In these systems, there is no direct communication with the locomotive cab; rather, the dispatcher sends commands to switches and wayside signals and receives feedback from them. Again, the wayside signal indicate authority to occupy a block or to proceed to the next block. These systems still require a human operation to control movement of the train in accordance with wayside signals. Updated CTC systems such as the Radio Actuated Code System from Harmon Electronics integrate differential GPS (global positioning system) technology and other technology into these systems, but they are still subject to human error.

Some efforts at automation have been made. For example, a rudimentary system known as Automatic Train Stop (ATS), sold by Union Switch and Signal Inc., functions by means of a mechanical contact between a wayside trip arm and a brake emergency trip switch or cock mounted to the car. If the wayside signal is in a stop condition and the train passes the signal, the wayside trip arm activates the emergency brake switch, thereby initiating an emergency brake operation. One problem with a rudimentary system such as this is that the braking operation is not started until the train passes the wayside switch, which means the train will not stop until some point after the switch. Thus, the system will not prevent a collision with an object that is close to the wayside signal.

Another problem with all of the foregoing system is that they require wayside signaling. These wayside signal systems are expensive to maintain and operate. Doing away with wayside signaling has been desired by train operators for many years.

5           The foregoing concerns have led to more automated systems. For example, in the Automatic Train Control (ATC) system, train location information, speed information, and train control information are continually exchanged between a train cab and computerized wayside controllers in real time (in some systems, track rails are used to carry this information). In this system, it is not necessary for a  
10 conductor or engineer to look for wayside signals. If a wayside signal is missed by a conductor or engineer, or conditions change after the wayside signal is passed, the information is available to the conductor or engineer in the cab. Some ATC systems automatically apply the brakes if a stop signal is passed. As discussed above in connection with the ABS system, such after-the-fact braking systems may  
15 not prevent collision with an object located in close proximity to a wayside signal. Other systems, such as the Advanced Train Control System proposed by Rockwell International, will automatically apply the brakes if a track warrant is about to be exceeded.

20           An advanced version of the ATC system, referred to as the Advanced Automated Train Control (AATC) system, is offered in combination with an Automatic Train Operation (ATO) system by General Electric Transportation Systems to fully automate movement of trains.

In at least one New Jersey Transit system, the ATC system has been combined with a Positive Train Stop (PTS) system. The PTS system uses



transponders along the tracks and on-board receivers to supplement the ATC system. PTS is an intelligent system that anticipates signaling and will stop or slow the train automatically without operator input. For example, as discussed above, while ATC will stop the train automatically if the train runs through a stop  
5 signal, PTS will stop the train before actually going through a stop signal. In addition, the PTS system allows for "civil-speed" and "temporary construction" speed restrictions. The term Advanced Speed Enforcement System (ASES) is used when ATC and PTS are combined.

Another system sold by Harmon Industries and referred to as Ultracab also  
10 involves an ATC system that will automatically stop a train before going through a stop signal. However, one drawback to both the PTS and Ultracab systems is that they assume the worst case scenario when automatically stopping a train, i.e., they employ a fixed braking curve. Thus, for example, when these system detect an upcoming stop signal, they will apply the brakes at a distance that assumes that the  
15 train is traveling downhill on the most steeply graded section of track, and that the train is at the maximum weight. This worst-case assumption/fixed braking curve makes such systems inefficient.

In more recent years a next generation train control system referred to as Positive Train Control, or PTC, has been proposed. A number of companies have  
20 proposed different systems that function in different ways to implement PTC systems. For example, GE Transportation Systems markets a product referred to as the Incremental Train Control System (ITCS) and GE Harris Railway Electronics markets a version referred to as Precision Train Control. The Federal Railroad Administration (FRA) has stated that from the point of view of safety objectives, a

PTC system needs to achieve the following core functions with a high degree of reliability and effectiveness: prevent train-to-train collisions (positive train separation); enforce speed restrictions, including civil engineering restrictions and temporary slow orders; and provide protection of roadway workers and their  
5 equipment operating under specific authorities.

In addition to the performance and safety issues discussed above, vandalism is becoming an increasing concern of train operators. One form of vandalism is the unauthorized moving of trains. Much like some people 'borrow' a car for joyriding, some will joyride on trains. Unlike cars, a key is often not required to  
10 "start" a train. While a locomotive cab may be locked, it is fairly easy to break the lock and enter the cab, at which point a train can be made to move. Unauthorized movement of a train, whether on a main line, in a train yard, or on some other section of track, can cause much damage even if a stop signal is not violated.

Another vandalism problem is the uncoupling of trains while the trains are  
15 at rest. Ordinarily, but not necessarily, if a car becomes detached from a train due to some mechanical failure, the loss in pressure in the brake lines will cause the trains to immediately stop. However, if a vandal disconnects a car from a train while in the yard and properly shuts the air valve for the brake line to the remaining cars, this protection does not work. When a train has many cars, a conductor or  
20 engineer may not notice that the car has been disconnected. In this case, the car left behind may cause a collision with an oncoming train or may just roll away and then cause a collision. This problem is partially solved by the use of known end-of-train devices that include motion sensors that allow a conductor or engineer in the locomotive cab to verify that the last car is in motion. However, the motion



sensors sometimes break or give false readings and, under certain circumstances described more fully herein, may mislead a conductor or engineer even when working properly.

5 What is needed is a method and system that allows for the efficient and safe operation of a railroad while mitigating the effects of vandalism.

### SUMMARY OF THE INVENTION

The present invention meets the aforementioned need to a great extent by providing a computerized train control system in which a dispatcher sends track warrants directly to a locomotive cab, and which will not allow the train to move at  
10 all, whether the train is on the main line or in a train yard, until an appropriate authority is received and that will automatically stop in the event of a computer failure or the train before the train can exceed a track warrant limit.

In one aspect of the invention, the system includes an end of train telemetry unit by which the cab can monitor movement of the last car in the train to ensure  
15 that no cars have been improperly separated from the train.

In another aspect of the invention, the system can operate in a semi-automatic mode in which a conductor or engineer is able to control movement of the train as long as no track warrant limits or stop signals are violated, and in a fully automatic mode in which the system controls movement of the train.

20 In yet another aspect of the system, a control module calculates a required stopping distance based on many factors, including but not limited to the length of the train, the number and type of loads and empties, the speed of the train, weight

of the train, number of locomotives and the curvature and grade of the track on which the train will be operating as it approaches a track warrant limit.

In another aspect of the invention, graduated as well as full braking 'penalties' can be imposed when an engineer or conductor fails to apply the brakes in a manner sufficient to comply with speed restrictions (permanent and/or temporary) and/or warrants/authorities. A full braking penalty applies sufficient brake pressure to cause the train to come to a complete stop. A graduated penalty increases the brake pressure until the train is in compliance with the signal or speed condition, or has slowed enough such that the distance between the train and a stop signal has become greater than the maximum amount of time required to stop the train under the currently applicable conditions.

In still another aspect of the invention, a positioning system is used to provide train location information, and map data is used to determine the location of other objects of interest such as stop signals, block boundaries, and restricted speed areas.

In accordance with a first broad aspect, there is provided a system for controlling a train, the system comprising: a control unit; a first positioning system located near a front of a train, the first positioning system being in communication with the control unit; and a second positioning system located near a rear of the train, the second positioning system being in communication with the control unit; wherein the control unit is configured to: monitor information from the first positioning system; monitor information from the second positioning system; compare the information from the first positioning system to the information from the second positioning system; and send a corrective signal for taking corrective action if the comparison indicates that the front of the train has become disconnected from the rear of the train.

In accordance with a second broad aspect, there is provided a computer implemented method for controlling a train, the method comprising: locating a

first positioning system near a front of a train; locating a second positioning system near a rear of the train; monitoring information from the first positioning system; monitoring information from the second positioning system; comparing the information from the first positioning system to the information from the second positioning system; and sending a corrective signal for taking corrective action if the comparison indicates that the front of the train has become disconnected from the rear of the train.

In accordance with a further broad aspect, there is provided a system for controlling a train, the system comprising: a control unit; a first main positioning system connected to the control unit; and a communications module connected to the control unit; wherein the control unit is configured to perform the steps of: accepting at least one authorization from a dispatcher, the authorization defining a boundary within which a train is authorized to move; send a prevention signal for preventing the train from moving from a current location if the current location is not within a boundary for an accepted authorization; monitoring a position from the main positioning system; and send a stop signal for stopping the train before the boundary is reached

### **BRIEF DESCRIPTION OF THE DRAWINGS**

A more complete appreciation of the invention and many of the attendant features and advantages thereof will be readily obtained as the same become better understood by reference to the following detailed description when considered in connection with the accompanying drawings, wherein:

Figure 1 is a logical block diagram of a train control system according to one embodiment of the invention.



Figure 2 is a perspective view of a display in the train control system of Figure 1.

### DETAILED DESCRIPTION OF PREFERRED EMBODIMENTS

The present invention will be discussed with reference to preferred  
5       embodiments of train control systems. Specific details, such as specific algorithms  
and hardware, are set forth in order to provide a thorough understanding of the  
present invention. The preferred embodiments discussed herein should not be  
understood to limit the invention.

Referring now to the drawings, wherein like reference numerals designate  
10       identical or corresponding parts throughout the several views, Figure 1 is a logical  
block diagram of a train control system 100 according to the present invention.  
The system 100 includes a control module 110, which typically, but not  
necessarily, includes a microprocessor. The control module 110 is the center of the  
train control system and is responsible for controlling the other components of the  
15       system. Connected to the control module is a communications module 120. The  
communications module is responsible for conducting all communications between  
the system 100 and the central dispatcher computer system (not shown in Fig. 1).  
These communications may occur in a variety of ways, such as over the air or  
through the rails of the train track. In some embodiments, wayside signals transmit  
20       information to the system 100. All equipment necessary for such communications  
(e.g., antennas) are connected to the communications module 120.

Also connected to the control module 110 is a positioning system such as a  
GPS receiver 130. The GPS receiver 130 can be of any type, including a

differential GPS, or DGPS, receiver. Other types of positioning systems, such as inertial navigation systems (INSs) and Loran systems, can also be used. Such positioning systems are well known in the art and will not be discussed in further detail herein. [As used herein, the term "positioning system" refers to the portion of a positioning system that is commonly located on a mobile vehicle, which may or may not comprise the entire system. Thus, for example, in connection with a global positioning system, the term "positioning system" as used herein refers to a GPS receiver and does not include the satellites that are used to transmit information to the GPS receiver.]

10           The GPS receiver 130 continuously supplies the control module 110 with position information concerning the train to which the control system 100 is attached. This information allows the control module 110 to determine where it is at any point in time. The GPS receiver is preferably sufficiently accurate to unambiguously determine which of two adjacent tracks a train is on. By using train position information obtained from the GPS receiver 130 as an index into the map database 140, the control module can determine its position relative to other points of interest on the railroad such as switches, sidings, stations, etc. As discussed in further detail below, this allows the control module 110 to warn the conductor or engineer if an authority (speed, position, etc.) is about to be exceeded and, if required, to automatically stop or slow down the train before the authority is exceeded.

In addition to the GPS receiver 130, an axle drive speed indicator 105 is also connected to the control module 110. The axle drive speed indicator 105 is a tachometer which measures the axle rotation, from which the speed of the train can

be derived if the wheel size is known. End-of-axle magnetic pick-ups are used in some embodiments. It is also possible to use a signal that measures the rotation speed of the motor driving the axle to perform this function. In the event that the GPS system becomes unavailable, the system can operate by estimating distance  
5 traveled from the rotation of the axle or motor. However, wheel slippage and changes in wheel size over time can effect the accuracy of such a system. The system 100 may be configured to compensate for wheel wear in the manner described in US Patent No. 6,701,228, issued March 2, 2004, entitled "Method and System for Compensating for Wheel Wear on a Train".

10 A map database 140 is connected to the control module 110. The map database 140 preferably comprises a non-volatile memory such as a hard disk, flash memory, CD-ROM or other storage device, on which map data is stored. Other types of memory, including volatile memory, may also be used. The map data preferably includes positions of all wayside signals, switches, grade crossings, stations and  
15 anything else of which a conductor or engineer is required to or should be cognizant. The map data preferably also includes information concerning the direction and grade of the track. Use of the information in the map database 140 will be discussed below.

A brake interface 150 is also connected to the control module 110. The brake  
20 interface monitors the brake and allows the control module 110 to activate and control the brakes when necessary. The brake interface 150 preferably includes an input board that inputs analog signals from pressure transducers connected to monitor the main reservoir pressure, brake pipe pressure and brake

25



cylinder pressure. The input board includes analog-to-digital converters to convert the analog signals from the transducers to digital signals. To ensure that the brake interface 150 is functioning properly, the control module 110 will feed a signal of a known constant voltage to the input board, where it will be converted into a digital  
5 signal and read back by the control module 110. If a failure in the brake interface 150 is detected, the dispatcher and the conductor/engineer will be notified and the brakes will automatically be applied and the control module 110 will not allow the train to be moved.

A head of train (HOT) transceiver 160 is also connected to the control  
10 module 110. The HOT transceiver 160 is in communication with a rear of train unit 170 that includes an end of train (EOT) GPS receiver 171 and an EOT transceiver 172 that is preferably located at the rear of the last car on the train. (As discussed above in connection with the GPS receiver 130, other types of positioning systems could be used in place of the EOT GPS receiver 171). The  
15 communication between the EOT transceiver 172 and the HOT transceiver 160 may be wireless methods, power line carrier methods, or by any other method. In operation, communications between the EOT GPS receiver 171 and the control module 110 are constantly monitored. If a message from the EOT GPS receiver 171 has not been received for some predetermined period of time, or if the data in  
20 the message has been corrupted (e.g., the speed in the message is faster than the train can travel), or does not agree with the information from the GPS receiver 130 in the locomotive at the front of the train, the control module 110 can either display an operator alert or, in some embodiments, stop the train and notify the dispatcher.

The EOT GPS receiver 170 allows the system 100 to detect when one or more cars has been disconnected from the train. As discussed above, vandalism in the form of someone purposely disconnecting one or more cars while trains are at rest is an important safety concern. If a vandal closes off the brake line valve, the  
5 disconnection may not be detected because, when trains are long, the end of the train may not be visible from the locomotive. In the past, yard personnel, conductors and/or engineers traveling on an adjacent track in the opposite direction have been relied on to read off the number on the last car in order to verify that no cars have been disconnected. However, such a system is not perfect for at least the  
10 reason that yard personnel or personnel on another train are not always available to perform this function.

End of train devices that employ a motion sensor are known. However, these devices do not fully ensure that the last car has not been disconnected. The motion sensor does not indicate speed; it simply indicates whether or not there is  
15 motion above some threshold. It is possible that a broken motion sensor will give an indication of motion when in fact there is no motion. In such a situation, the conductor or engineer has no way of knowing that the car has been disconnected.

Furthermore, even when the motion sensor is working properly, it is possible that a disconnection may not be detected. In one incident known to the  
20 inventors, a distributed power train (a train in which one or more locomotives is placed at the front of the train, followed by one or more cars, followed by one or more additional locomotives and cars) was temporarily stopped at a crossing. While stopped, a vandal disconnected the second group of locomotives from the preceding car, and closed off the brake valves. In this train, the second group of



cars connected to the second group of locomotives was heavier than the first group of cars connected to the first group of locomotives. When the conductor or engineer in the lead locomotive in the first group began moving the train by setting the throttle to a desired position, the throttles in all the other locomotives in both  
5 groups was set by radio control to the same position. Because the second group of cars was heavier than the first, there was a difference in speed between the two portions of the train and the first portion of the train began to separate from the second portion. The EOT motion sensor transmitted the correct status that the EOT (last car) was moving although it did not indicate the train was separated. In  
10 this incident, the separation grew to over a mile before the engineer noticed that there was a problem. The danger in such a situation is obvious.

In the foregoing case, an end of train device with a motion sensor would not have alerted the conductor or engineer to the problem because the second portion of the train was moving, albeit at a slightly slower pace. However, with a GPS  
15 receiver, the separation between the portions of the trains would have been readily apparent. Furthermore, unlike a motion sensor, if a GPS receiver fails, it is readily apparent as either there is no data, or the data doesn't change, or the data is obviously wrong.

When the train is moving, the control unit 110 periodically checks the two  
20 positions reported by the GPS receiver 130, 171, calculates the actual distance between them, and compares this actual distance to an expected distance. If the actual distance exceeds the expected distance, the control unit 110 takes corrective action.



In some embodiments, the distance between the EOT GPS receiver 171 and the GPS receiver 130 at the front of the train is calculated as a straight-line distance. This straight-line distance will necessarily decrease when the train is traveling along a curved section of track. Some embodiments simply ignore this decrease and compare the difference in positions reported by the two receivers to a static expected distance between the receivers based on the assumption that the train is on a straight section of track, taking corrective action only when the actual distance exceeds this static expected difference. In some embodiments, this static distance is based on the consist information (which may include the length of the train, or the number of cars and their length or their type - from which length can be determined - or other data that allows the length of the train to be calculated) reported to the train by the dispatcher. This method allows the monitoring function to be performed if the map database 140 is not provided in the system 100 or is not functioning. Other embodiments utilize the map database 140 to determine the amount of curvature on the track section between the GPS receiver 130 and the EOT GPS receiver 171 and correspondingly decrease the expected distance between the two GPS receivers as a function of this curvature. In this fashion, if the last car becomes detached from the first car on a curved section of track, the situation can be more quickly recognized.

Using a positioning system such as an EOT GPS receiver 171 in the end of train device also eliminates the need to use train detection circuits at track locations near wayside signals. In many existing railroads, circuits detect when a train has passed a wayside signal and notify the dispatcher and/or other trains of this event. If an end of train positioning system is used, the fact that the end of train has

passed the wayside signal can be transmitted from the cab to the dispatcher, thereby eliminating the need for a sensing circuit on the tracks to verify that the end of train has passed the signal.

A display 180 connected to the control module 110 is used to present various information to the conductor or engineer. An exemplary display 200 is illustrated in Fig. 2. The display 200 shows the current train speed in field 210 and the maximum allowable speed (if a maximum is in effect) in field 212. The display 180 also shows the train's exact position in field 214 and the limits of the train's authority at field 216. Also included in the display 180 is a first graph 218 indicating the grade of the tracks in the immediate area of the train and a second graph 220 indicating the direction of the track relative to the locomotive cab. The display 180 also lists, in fields 222 and 224, current and upcoming speed restrictions over limited areas of the track (in the example of Fig. 2, the speed restrictions are "Form A" speed restrictions, which will be discussed in further detail below).

The display also includes a number of acknowledgment buttons 230 as recited in U.S. Patent No. 6,112,142. As the train approaches a wayside signal, the state of the signal is transmitted via radio to the system. When the operator sees the wayside signal, the operator must acknowledge the wayside signal by pressing a corresponding acknowledgment button. Thus, for example, if a wayside signal indicates 'slow,' the conductor or engineer must acknowledge the signal by pressing the slow button 230a. In this fashion, a record of the conductor's or engineer's alertness can be kept. If the conductor or engineer fails to acknowledge the wayside signal, a warning is shown on the display 180 and, if the conductor or



engineer does not take corrective action, the system 100 automatically takes the required corrective action to ensure compliance with the wayside signal. Such corrective action can include a full braking penalty (wherein the brakes are applied such that the train stops) or a graduated braking penalty. In a graduated braking  
5 penalty, the brake pressure is increased until the train is in compliance with the signal, but may not involve actually stopping the train.

Because information from wayside signal is transmitted into the cab, wayside signaling lights are not necessary. Maintaining these lights on wayside signals is expensive, both because the bulbs are expensive and because the bulbs  
10 must be replaced periodically before they blow out. With wayside devices that transmit information to a cab, maintenance need only be performed when the device stops working and the time between failures is much longer; thus, the time between required maintenance trips to such wayside devices is much longer than is the case with lit wayside signal devices.

15 An event recorder 190 is also connected to the control module 110. The event recorder 190 serves a purpose similar to that served by a "black box" cockpit recorder in an airplane. The event recorder 190 records operating data, including communications to and from the train control system 100 and records operator actions such as acknowledgments of wayside signals as discussed above for  
20 investigation and/or training purposes.

The train system 100 is capable of two modes of operation. In the semiautomatic mode, movement of the train is under the control of the conductor or engineer provided that the conductor or engineer operates the train in an acceptable manner. In the automatic mode, the system 100 controls the movements



of the train. In this mode, the conductor or engineer intervenes only when necessary to deal with unforeseen situations, such as the presence of an unauthorized person or thing on the tracks.

In some embodiments of the invention, movement of the train is governed by warrants and authorities. Track on the main line (whether or not passing through a train yard) is typically under control of a dispatcher. Track warrants, sometimes referred to as track authorities, are issued by the dispatcher to control the movement of the train on the main line track. A track warrant is essentially a permission for a train to occupy and move on a section of main line track. The track warranty has start and end points, which are sometimes referred to as limits of authority. The start and end point together define a "block" of main line track. The track warrant may permit a train to move in one or both directions along the track, and may or may not be time- and speed-limited.

In contrast to main line track, movement of trains in a train yard is typically under the control of a yardmaster. The yardmaster is responsible for the movement of trains in a train yard, including movement of trains within the train yard (e.g., movement of a train from a resting place to a fuel depot or a repair facility) or from the yard to the main line track. The term "circulation authority" has sometimes been used, and will be used herein, to refer to an authority that permits a train or locomotive to move within an area of track (such as a train yard) not controlled by a dispatcher, or from an area of track not controlled by a dispatcher to an area of track that is controlled by a dispatcher. The circulation authority may be a simple permission for the train to move, or may provide start and end locations (e.g., the

end location may correspond to the start location of the track warrant and the start location may correspond to the current location of the train/locomotive).

Circulation authorities and track warrants are sent to the control module 110. The authorities may be sent using wireless communications or by other means. Wayside transmitters may be installed along the track for the purpose of facilitating communications between the dispatcher and the train. The entities issuing the circulation authorities and track warrants may be a human being or a computer. The entity issuing a track warrant may be separate from or the same as the entity issuing a circulation authority.

As discussed above, vandalism concerning the unauthorized movement of trains is a serious problem. The present invention mitigates this problem by ensuring that the train has permission to move on the segment of track on which it is located before it can be moved at all. By way of comparison, while some of the descriptions of PTS systems the inventors hereof have seen in trade publications apparently indicate that a train will not be allowed to move until it has received a track warrant from a dispatcher (i.e., a track warrant or track authority), it appears that such systems will not prevent a vandal (or negligent engineer/ conductor) from moving a train in a train yard after the train has received the track warrant but before the train has received a circulation authority to move the train to the section of main line track for which the dispatcher has issued the track warrant. Such unauthorized movement of the train can obviously cause much damage. In contrast, some embodiments of the system 100 will not allow a train that has received a track warrant to move until it has received a circulation authority to move to the section of main line track corresponding to the track warrant.



Alternatively, some embodiments will accept an authority that includes both a block of main line track and an area of non-main line track. (In such systems, either a single entity controls both main line track and non-main line track, or the dispatcher and yardmaster communicate with each other so that such an authority  
5 may be issued).

Once an authority has been received by the system 100, the system 100 allows the conductor or engineer to move the train within the limits of that authority. As discussed above, a track warrant (or track authority) permits the operator to move the train along a block of main line track. The block is typically  
10 defined by specified mileposts or other boundaries. In addition to geographic limitations, authorities may also be limited by direction (i.e., a train may be authorized to move only north in a given block, or may be given authority to move back and forth along the track in the block) and/or speed.

All authorities are maintained in memory by the control module 110. When  
15 authorities are received from the dispatcher or yard master, all existing authorities are transmitted back to the dispatcher/yard master for verification. If the repeated authorities are correct, the dispatcher/yard master transmits an acknowledgment. Only after the acknowledgment is received is the train allowed to move. After this initial exchange, the dispatcher/yard master periodically transmits the current  
20 authority (or a number or other code associated with the current authority) to the control module 110. This serves as a "heartbeat" signal to the control module 110. When the current authority is received by the control module 110, it is checked against the authority that the control module believes is current. If the two authorities don't match, or if a current authority message has not been received for



some threshold period of time, the control module 110 immediately stops the train and notifies the dispatcher of this event.

In addition to authorities, the control module 110 keeps track of other restrictions on movement of the train, such as wayside signals (which may or may not be under the control of the central dispatcher/authority), and permanent, temporary, and train-based speed restrictions. Temporary speed restrictions are sometimes referred to as Form A, Form B or Form C restrictions. Form A restrictions are typically issued as a result of temporary track conditions; e.g., if a section of track is somewhat damaged but still passable, a temporary speed restriction is issued. Form B speed restrictions are typically issued when maintenance personnel or some other personnel are on the track. Form C restrictions, which are mostly used in the northeastern U.S., are similar to Form A restrictions in that they involve track conditions. Train-based restrictions are based upon the type of train and/or locomotive.

If the train is in danger violating any authority, speed limit, wayside signal, or other restriction, the system 100 first takes corrective action in the form of warning the conductor or engineer via the display 180. If the conductor or engineer fails to take the requisite corrective action, the system 100 automatically implements further corrective action, such as applying a brake penalty. For example, the control module will monitor the train's position and determine its distance and time from the boundary of its authority being approached. The control module will also calculate the time and/or distance required to stop the train using the equations of physics, basic train handling principles and train control rules. This time/distance will depend upon factors such as the speed of the

train, the weight and length of the train, the grade and amount of curvature of the  
upcoming track (which are determined using position information from the GPS  
receiver 130 as an index into the map database 140), braking power, braking ratios,  
type of brake equipment, aerodynamic drag of the train, etc. In more sophisticated  
5 embodiments, the location and weight of each car will be taken into account rather  
than simply a total weight of the train as differences in weight between cars  
becomes important when the different cars are on sections of track with different  
grades. A safety factor will be added in and, as a general rule, the safety factor can  
be smaller as additional information is taken into account because the equations  
10 should become more accurate.

The braking penalty may be full or graduated. A full braking penalty  
involves applying sufficient brake pressure to stop the train. Such a braking  
penalty may be imposed, for example, when the system is in semi-automatic mode  
and the engineer/conductor fails to acknowledge a stop signal. Completely  
15 stopping the train makes sense in this situation as the failure to acknowledge a stop  
signal may indicate that the conductor/engineer has become incapacitated. In this  
situation, the train may remain stopped until a central dispatcher authorizes the  
train to move again, thereby allowing the central dispatcher to ascertain the reason  
for the missed stop signal and to ensure that it is again safe to allow the train to  
20 move.

A graduated braking penalty involves applying brake pressure until the train  
is in compliance with the signal, restriction or other condition. For example, when  
a train violates a temporary speed restriction, the brakes may be applied until the  
train has slowed to the maximum allowable speed. As another example, the brake

pressure may be adjusted to reduce the speed of the train to ensure that the speed is such that the train is further away from a stop signal than the maximum distance required to stop the train. With such a graduated penalty, the brakes will be applied until the train slows to a stop just before the stop signal.

5           Communications between the various components of the system 100 can be conducted using methods currently developed or developed in the future. In some embodiments employing a modular construction wherein logical portions of the system are in separate physical units, one form of communication that may be used is power line carrier communication. Power line carrier communication involves  
10           transmitting information signals over conductors carrying electrical power (power line carrier communication is well known to those of skill in the art and thus will not be discussed in further detail herein). Thus, for example, communications between the HOT transceiver 160 and the EOT transceiver 172 may be performed using power line carrier methods.

15           In some embodiments, power line communications or other communication methods may be employed to provide for redundancy in the case of a system failure. For example, in some embodiments, if a portion of the system such as the GPS receiver 130 fails in the lead locomotive of a multi-locomotive consist, the control module 110 may communicate via power line communication (or other)  
20           methods with the next-closest GPS receiver 130 in one of the other locomotives near the front of the train. In such embodiments, a complete system 100 may be formed from components in a number of different locomotives/cars on a single consist.



In some embodiments, a collision avoidance feature is also included. In such embodiments, each train transmits its current location and speed, and receives current locations and speeds from other trains. This allows the control module 110 to automatically detect that a collision will occur and take appropriate corrective  
5 action, which can include stopping the train, warning the other train to stop, and warning the operator and the dispatcher.

In other embodiments, the central dispatcher sends the location, speed and direction of each of the other trains in a nearby area to the control module 110. The control module 110 displays this information in graphical form on the display  
10 180 in a PPI (plan position indicator) format similar to the graphical representation of aircraft on an air traffic controller screen (e.g., with a graphical vector wherein the orientation of the vector indicates the direction in which the other trains are traveling and the length of the vector indicates the speed). This allows  
conductors/engineers to quickly detect potential collisions and take action to avoid  
15 such collisions.

In the embodiments discussed above, the control module 110 is located on the train. It should also be noted that some or all of the functions performed by the control module 110 could be performed by a remotely located processing unit such as processing unit located at a central dispatcher. In such embodiments,  
20 information from devices on the train (e.g., the brake interface 150) is communicated to the remotely located processing unit via the communications module 120.

Obviously, numerous modifications and variations of the present invention are possible in light of the above teachings. It is therefore to be understood that within the scope of the appended claims, the invention may be practiced otherwise than as specifically described herein.

**WHAT IS CLAIMED IS:**

1. A system for controlling a train, the system comprising:

a control unit;

a first positioning system located near a front of a train, the first positioning  
5 system being in communication with the control unit; and

a second positioning system located near a rear of the train, the second  
positioning system being in communication with the control unit;

wherein the control unit is configured to:

monitor information from the first positioning system;

10 monitor information from the second positioning system;

compare the information from the first positioning system to the  
information from the second positioning system; and

send a corrective signal for taking corrective action if the comparison  
indicates that the front of the train has become disconnected from the rear of  
15 the train.

2. The system of Claim 1, wherein the information from the first positioning  
system and the information from the second positioning system comprises speed  
information.

3. The system of Claim 1, wherein the information from the first positioning  
20 system and the information from the second positioning system comprises position  
information.

4. The system of Claim 1, wherein the information from the first positioning  
system and the information from the second positioning system comprises position  
and speed information.

25 5. The system of Claim 1, wherein the control unit is configured to send the  
corrective signal for activating a train brake to stop the train.



6. The system of Claim 1, further comprising a display connected to the control unit, wherein the control unit is configured to send the corrective signal for displaying an alert on the display.

7. The system of Claim 1, further comprising a communications interface  
5 connected to the control unit, the interface being configured to provide communications between the control unit and a dispatcher.

8. The system of Claim 7, wherein the control unit is configured to send the corrective signal for alerting the dispatcher that the front of the train has become disconnected from the rear of the train.

9. The system of Claim 1, wherein the control unit is further configured to send  
10 the corrective signal if the information from the second positioning system is not received within a predetermined time period.

10. The system of Claim 1, wherein the control unit is further configured to send  
15 the corrective signal if the information from the second positioning system is corrupted.

11. The system of Claim 1, wherein the first positioning system and the second positioning system comprise global positioning system receivers.

12. The system of Claim 1, wherein the control unit is further configured to  
20 perform the comparison by calculating a distance between position information reported by the first positioning system and position information from the second positioning system and comparing this difference to a threshold.

13. The system of Claim 12, wherein the threshold determined is static and is  
25 based on the distance between the first positioning system and the second positioning system when all cars on the train are connected and present on a straight track.

14. The system of Claim 12, wherein the predetermined threshold is based on consist information reported by a dispatcher.

15. The system of Claim 12, wherein the control unit is further configured to adjust the threshold as a function of a curvature of a track on which the train is traveling.

16. A computer implemented method for controlling a train, the method comprising:

locating a first positioning system near a front of a train;

locating a second positioning system near a rear of the train;

5 monitoring information from the first positioning system;

monitoring information from the second positioning system;

comparing the information from the first positioning system to the information from the second positioning system; and

10 sending a corrective signal for taking corrective action if the comparison indicates that the front of the train has become disconnected from the rear of the train.

17. The computer implemented method of Claim 16, wherein the information from the first positioning system and the information from the second positioning system comprises speed information.

15 18. The computer implemented method of Claim 16, wherein the information from the first positioning system and the information from the second positioning system comprises position information.

19. The computer implemented method of Claim 16, wherein the information from the first positioning system and the information from the second positioning system  
20 comprises position and speed information.

20. The computer implemented method of Claim 16, wherein the sending the corrective signal comprises sending an activation signal for activating a train brake to stop the train.

21. The computer implemented method of Claim 16, wherein the sending the  
25 corrective signal comprises sending an alert signal for displaying an alert on a display.

22. The method of Claim 16, wherein the sending the corrective signal comprises sending an alert signal for alerting a dispatcher that the front of the train has become disconnected from the rear of the train.

23. The computer implemented method of Claim 22, wherein the sending the corrective signal further comprises sending a stop signal for stopping the train.

24. The computer implemented method of Claim 16, wherein the sending the corrective signal further comprises sending the corrective signal if information from the second positioning system is not received within a predetermined time period.

25. The computer implemented method of Claim 16, wherein the sending the corrective signal further comprises sending the corrective signal if information from the second positioning system is corrupted.

26. A system for controlling a train, the system comprising:

a control unit;

a main positioning system connected to the control unit; and

a communications module connected to the control unit;

wherein the control unit is configured to :

accept at least one authorization from a dispatcher, the authorization defining a boundary within which a train is authorized to move;

send a prevention signal for preventing the train from moving from a current location if the current location is not within a boundary for an accepted authorization;

monitor a position from the main positioning system; and

send a stop signal for stopping the train before the boundary is reached.

27. The system of Claim 26, wherein the control unit is configured to calculate a stopping distance required to stop the train based in part upon a weight of the train and a speed of the train and send an activation signal for activating a train brake before a distance between the train and the boundary is less than the stopping distance.



28. The system of Claim 27, further comprising a display connected to the control unit, wherein the control unit is further configured to display a warning on the display before activating the train brake.

29. The system of Claim 28, wherein the control unit is further configured to  
5 compare a speed received from the main positioning system to a maximum allowable speed and apply a train brake if the speed received from the main positioning system is greater than the maximum allowable speed.

30. The system of Claim 27, wherein the stopping distance is further based on a track grade.

10 31. The system of Claim 30, wherein the track grade is determined using position information from the main positioning system as an index into a map database that includes track grade information.

32. The system of Claim 27, wherein the control unit is configured to send the activation signal for imposing a full braking penalty.

15 33. The system of Claim 27, wherein the control unit is configured to send the activation signal for imposing a graduated braking penalty.

34. The system of Claim 26, further comprising an additional positioning system located at a last car in the train, the additional positioning system being in  
communication with the control unit, the control unit being further configured to  
20 compare information from the main positioning system and the additional positioning system and send a corrective signal for taking corrective action if the comparison indicates that the last car has become separated from an other car in which the first global positioning system is located.

25 35. The system of Claim 34, wherein the control unit is configured to send the corrective signal for stopping the train.

36. The system of Claim 34, wherein the control unit is configured to send the corrective signal for displaying an alert on a display connected to the control unit.

37. The system of Claim 34, wherein the control unit is configured to send the corrective signal for notifying a dispatcher.

38. The system of Claim 26, wherein the control unit is further configured to transmit current position and speed information for the train, receive position and speed information pertaining to other trains, determine that a collision will occur based on the position and speed information, and send the corrective signal for preventing the collision.

39. The system of Claim 38, wherein the position and speed information pertaining to other trains is received from a dispatcher.

40. The system of Claim 38, wherein the position and speed information pertaining to other trains is received from the other trains.

41. The system of Claim 38, wherein the current position and speed information for the train are transmitted to a dispatcher.

42. The system of Claim 38, wherein the current position and speed information for the train are transmitted to the other trains.

43. The system of Claim 38, wherein the location of other trains is displayed in a graphical format.

44. The system of Claim 43, wherein the graphical format includes a vector indicating speed and direction.

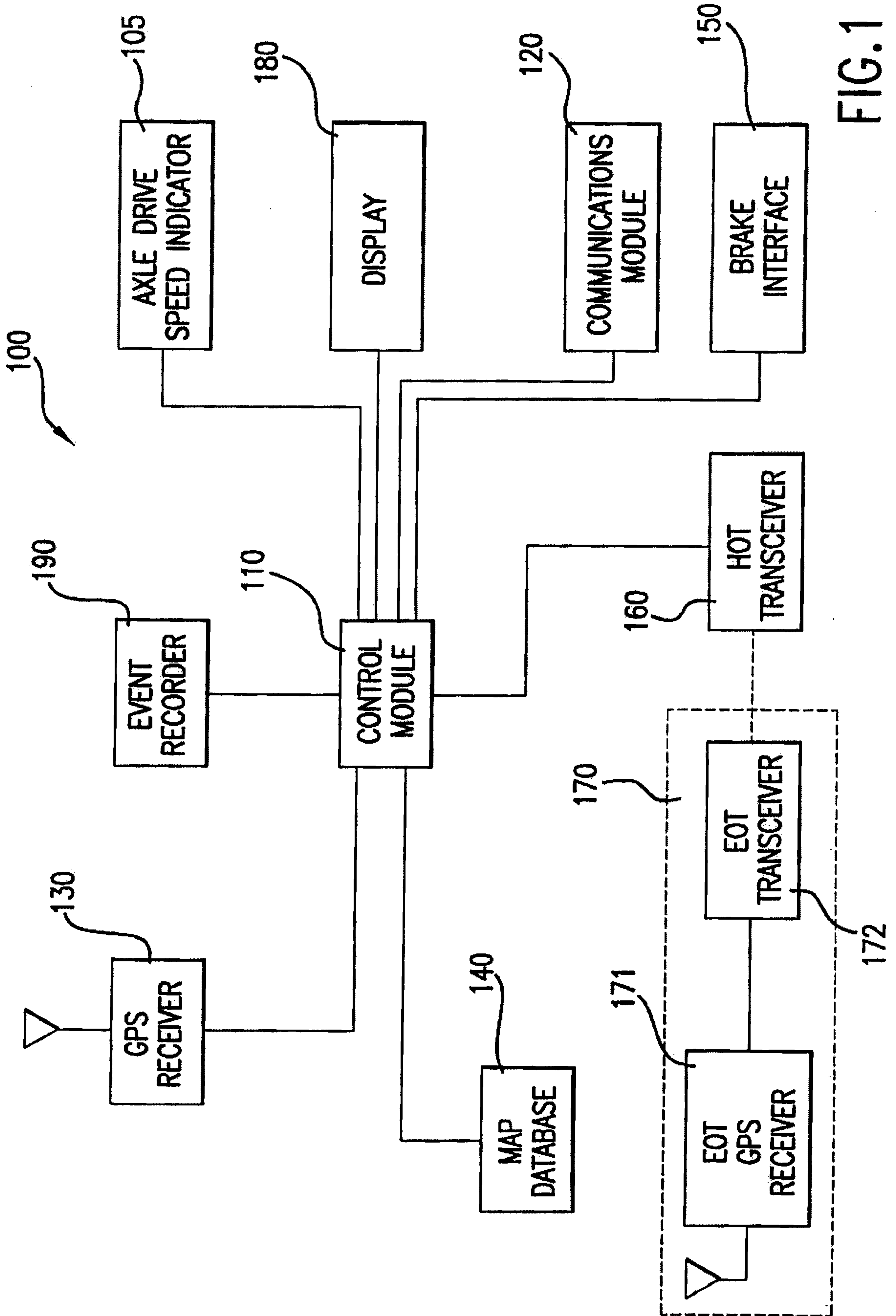

FIG. 1



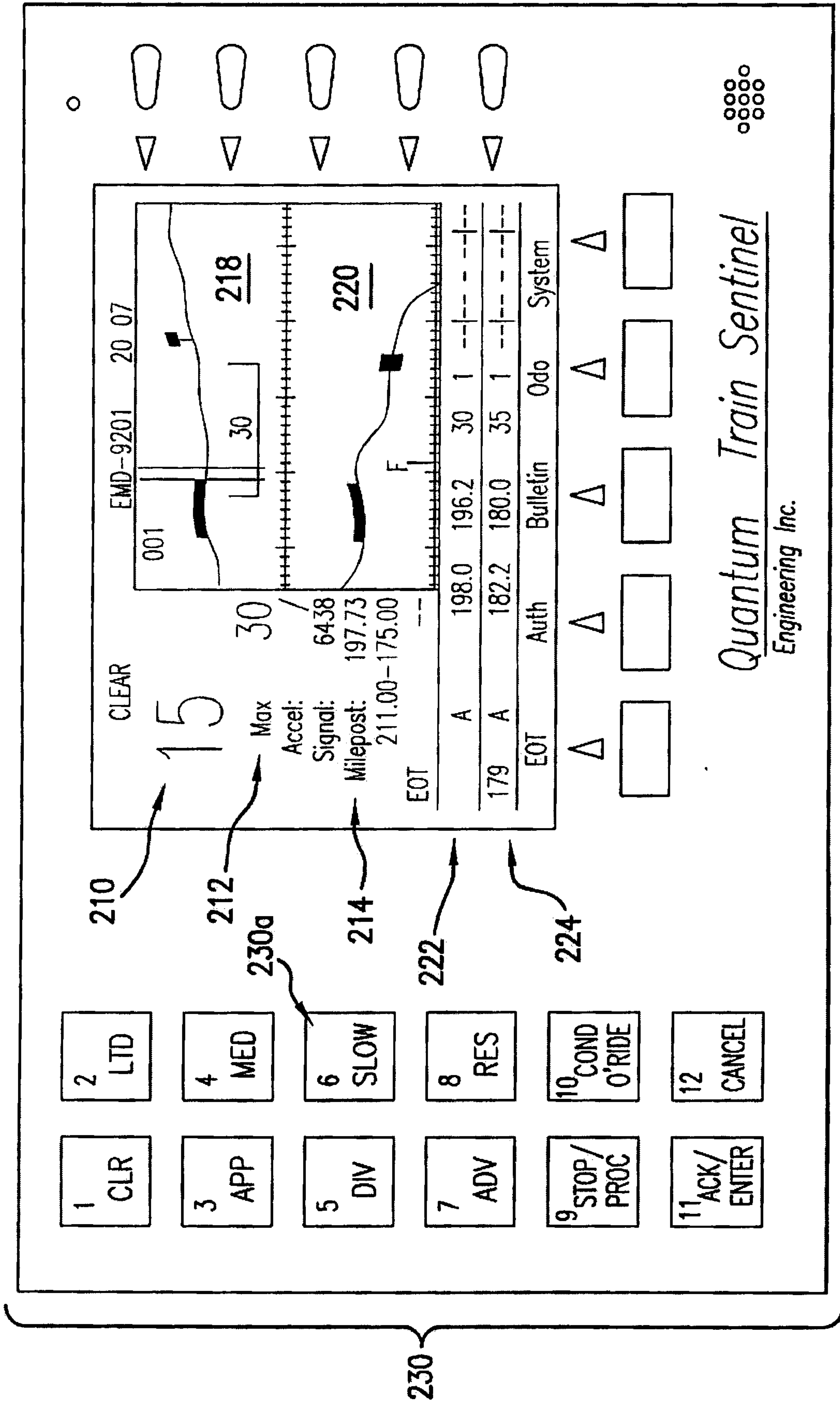

FIG.2

