

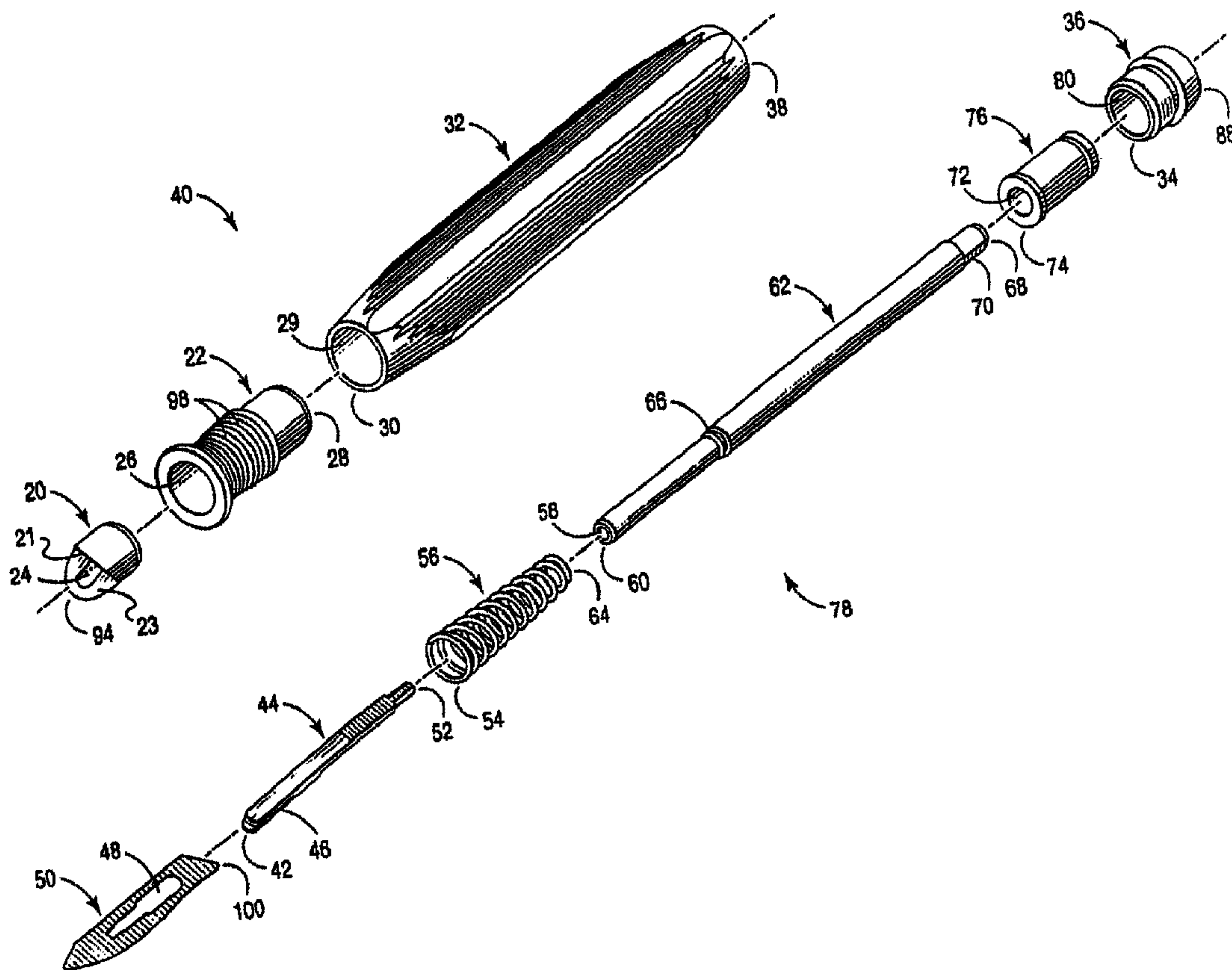

(86) Date de dépôt PCT/PCT Filing Date: 2000/04/07
 (87) Date publication PCT/PCT Publication Date: 2000/10/19
 (45) Date de délivrance/Issue Date: 2005/01/11
 (85) Entrée phase nationale/National Entry: 2001/09/20
 (86) N° demande PCT/PCT Application No.: IB 2000/000426
 (87) N° publication PCT/PCT Publication No.: 2000/061014
 (30) Priorité/Priority: 1999/04/09 (60/128,529) US

(51) Cl.Int.⁷/Int.Cl.⁷ A61B 17/32
 (72) Inventeurs/Inventors:
 BELL, MICHAEL S. G., CA;
 LEE, LEONARD G., CA;
 O'MALLEY, MICHAEL T., CA;
 MAXWELL, TIMOTHY J., CA
 (73) Propriétaire/Owner:
 CANICA DESIGN INC., CA
 (74) Agent: HENDRY, ROBERT G.

(54) Titre : ENSEMBLE SCALPEL
 (54) Title: SCALPEL ASSEMBLY



(57) Abrégé/Abstract:

A scalpel assembly utilizing an ejectable blade allowing easy installation and removal of the blade. Use of an ejectable blade permits a used or contaminated blade to fall freely from the scalpel assembly without direct contact with the blade.

ABSTRACT

A scalpel assembly utilizing an ejectable blade allowing easy installation and removal of the blade. Use of an ejectable blade permits a used or contaminated blade to fall freely
5 from the scalpel assembly without direct contact with the blade.

SCALPEL ASSEMBLY

BACKGROUND OF THE INVENTION

1. Field of the Invention

5 This invention relates to a scalpel having a releasable, detachable or disposable blade and a reusable scalpel assembly.

2. Description of Related Art

Surgical scalpels have long been available, including such devices utilizing detachable or disposable blades that have a keyed or keyhole shaped slot. There is a need
10 for a scalpel with better ergonomic properties. In addition, there is a need for a scalpel assembly that allows easy installation of a blade and that allows easy, safe release of a detachable or disposable blade and that can be manipulated with one hand. There is also a need for such a scalpel assembly to be durable and able to withstand repeated autoclaving and other sterilization techniques.

15

SUMMARY OF THE INVENTION

This invention is a scalpel assembly for disposable or detachable blades ejectable with the push of a button. This allows a used or contaminated blade to fall freely from the scalpel assembly into a disposal receptacle, such as a sharps container, without direct
20 contact of medical personnel with the used or contaminated blade. A conventional disposable or detachable blade having a keyed slot is utilized and engaged by a blade bar that extends from a handle assembly. This blade bar may be extended with one hand by manipulating a push button or other actuator, releasing the blade from the handle. The push button is located on the handle remote from the blade, so that contact between the
25 user's fingers and the blade is unnecessary and unlikely.

Accordingly, it is a feature of this invention to provide a scalpel assembly that allows release of a blade without requiring medical personnel to touch the blade.

It is a further feature of this invention to provide a scalpel assembly that allows release of a blade by manipulation with one hand.

30 Another feature of this invention is to provide a scalpel assembly that allows easy blade installation.

It is another feature of this invention to provide a scalpel assembly that is durable, and capable of withstanding repeated sterilization.

Another feature of this invention is to provide a scalpel assembly with desirable ergonomic properties.

5 This invention can be better understood by reference to the Brief Description of the Drawings, which should not be interpreted to limit the scope thereof.

BRIEF DESCRIPTION OF THE DRAWINGS

10 FIG. 1 is an exploded perspective view of one embodiment of the scalpel handle assembly of this invention.

FIG. 2 is an exploded perspective view of the handle body assembly of the scalpel assembly shown in FIG. 1.

FIG. 3 is a side elevation view of the assembled handle body assembly of FIG. 2.

15 FIG. 4 is an exploded perspective view of a button assembly forming a part of the scalpel assembly of one embodiment of this invention.

FIG. 5 is a side elevation assembly view of the button assembly of FIG. 4.

FIG. 6 is a top plan view of the proximal portion of the blade bar of this invention.

FIG. 7 is a side elevation of the proximal portion of the blade bar of this invention.

FIG. 8 is a top plan view of the scalpel assembly of FIG. 1.

20 FIG. 9 is a side elevation view of the scalpel assembly of FIG. 1.

FIG. 10 is a longitudinal section view of the push rod shown in FIG. 1.

FIG. 11 is a side elevation section view of the button retainer shown in FIG. 1.

FIG. 12 is a side elevation view in section of the button shown FIG. 1.

25 FIG. 13 is a perspective view of a collet core forming part of the handle body assembly shown in FIG. 8.

FIG. 14 is an end elevation view of the collet core of FIG. 13.

FIG. 15 is a side elevation section view of the collet core of FIG. 13.

FIG. 16 is a perspective view of the collet of the handle body assembly of FIG. 2.

FIG. 17 is an enlarged end elevation view of the collet of FIG. 16.

30 FIG. 18 is a side elevation section view of the collet of FIG. 16.

FIG. 19 is a side elevation view of a push rod forming part of the button assembly of an alternative embodiment of this invention.

FIG. 20 is a side elevation section view, in section, of the button forming part of a button assembly of an alternative embodiment of this invention.

5 FIG. 21 is a side elevation view, in section, of the button retainer forming part of the handle assembly of an alternative embodiment of this invention.

DETAILED DESCRIPTION

This invention relates to a scalpel having an easily detachable, optionally
10 disposable blade that can be removed by actuation of a button with the same hand holding the scalpel assembly. This eliminates the need for medical personnel to handle or touch the blade after the blade has come into contact with surgical patients or their body fluids.

The scalpel is an ergonomic surgical instrument, and the disposable or detachable scalpel blade need be handled only when it is sterile and is being attached to the scalpel
15 assembly, if at all. In a more particular embodiment of this invention, the scalpel assembly comprises an attachment mechanism for receiving and engaging a disposable or detachable scalpel blade, and may desirably be adapted to receive and engage conventional scalpel blades. As used in the description of the scalpel assembly of this invention, a proximal end is one nearer to the blade tip and a distal end is one remote from
20 the blade tip.

The scalpel assembly includes a handle body, which provides a surface for the surgeon or medical personnel to grip the scalpel during transport or use. A button assembly inside the handle body serves to allow attachment and detachment of the blade from the scalpel assembly. The handle assembly is made up of a collet core, a collet, a
25 handle body, and a button retainer. The collet houses the collet core. The proximal end of the handle body is attached to the collet. The interior surface of the distal end of the handle body is adapted to receive and engage the proximal end of the button retainer after the button assembly is inserted into the handle assembly. The button assembly is made up of a blade bar, a spring, which may be tapered, a push rod, and a button. The blade bar
30 contains a groove and heel forming a tang, which allows it to engage a blade. The proximal end of the spring engages the interior of the handle assembly, desirably toward

the proximal end. For example, the spring may engage the distal end of the collet. The distal end of the spring is engaged by the push rod. The distal end of the blade bar is engaged with the proximal end of the push rod. The proximal end of the button is attached to the distal end of the push rod. Alternatively, two or more of the button, the push rod and the blade bar may be an integral component. Depression of the button compresses the spring and extends the blade bar, disengaging the blade. In alternative embodiments, the push rod may be actuated by a button, lever, slide or other mechanism located intermediate the ends of the handle rather than at the handle's distal end.

This invention is described below by reference to the drawings; however, it should be understood that the drawings are directed to a specific embodiment of the invention and do not limit the scope thereof.

As shown in FIG. 1, the scalpel assembly 86 of one embodiment of this invention includes a handle body assembly 40 and a button assembly 78. The handle body assembly of this embodiment contains collet core 20 housed within collet 22. Collet core 20 is penetrated by bore 24, which provides for movement of blade bar 44 in and out of, and laterally within, collet core 20 during engaging and releasing of the blade 50 in response to depressing button 76. Collet core 20 also contains a pair of sloping front surfaces 21 and 23. Collet core 20 is inserted into collet hole 26 of collet 22 with a press fit, as shown in FIGS. 2 and 3. Distal end 28 of collet 22 is inserted into body bore 29 at proximal end 30 of handle body 32 with a press fit, as shown in FIGS. 2 and 3. In an alternative embodiment, either the button assembly, the handle body assembly, or both, may be manufactured as a single unit. Proximal end 34 of button retainer 36 is connected to distal end 38 of handle body 32.

The button assembly 78 contains blade bar 44, tapered coiled spring 56, push rod 62, and button 76. As best shown in FIGS. 6 and 7, proximal end 42 of blade bar 44 contains a groove 46. Groove 46 in the proximal end 42 of blade bar 44 and extending along portions of two of the blade bar's opposed sides, and a heel 45, define a tang 47 that is received in keyed slot 48 in blade 50. When tang 47 is inserted in keyed slot 48 of blade 50, the narrower portion of keyed slot 48 engages the u-shaped groove 46 in proximal end 42 of blade bar 44.

Reduced diameter distal end 52 of blade bar 44 enters proximal end 54 of tapered coiled spring 56, telescopes through tapered coiled spring 56, and is received in push rod bore 58 in proximal end 60 of push rod 62. Tapered coiled spring 56 is telescopingly connected to proximal end 60 of push rod 62, so that smaller diameter distal end 64 of tapered coiled spring 56 is captured by notch 66 on push rod 62. As shown in FIGS. 1 and 4, distal end 68 of push rod 62 contains a recess or flat surface 70. This recess 70 allows air to escape when reduced diameter distal end 68 of push rod 62 is telescopingly inserted into button bore 72 in proximal end 74 of button 76.

FIGS. 4 and 5 illustrate how blade bar 44, tapered coiled spring 56, push rod 62 and button 76 combine to form button assembly 78. Blade bar 44 is formed at an angle 79 to allow blade 50 to be freely inserted or removed in the extended position of the scalpel assembly, and held in place on blade bar 44 upon retraction, further described below. Button assembly 78, shown in FIG. 5, is inserted into handle assembly 40, shown in FIG. 3, before button retainer 36 is connected to distal end 38 of handle body 32. Button retainer 36 is then connected to distal end 38 of handle body 32 so that button 76 passes through button retainer bore 80. Proximal end 34 of button retainer 36 is threadedly connected to distal end 38 of handle body 32. Proximal end 74 of button 76 is held in place in handle body 32 by button retainer 36. Scalpel assembly 86 is shown in FIGS. 8 and 9.

FIG. 10 shows push rod 62. Push rod bore 58 is located at proximal end 60 of push rod 62. Recess 70 is located at distal end 68 of push rod 62. Push rod 62 has annular depression or notch 66. As shown in FIG. 11, distal end 88 of button retainer 36 can be knurled to make disassembly easier. Threads 92 on button retainer 36 allow button retainer 36 to be joined to distal end 38 of handle body 32. FIG. 12 shows button 76, which has button bore 72 at proximal end 74.

FIGS. 13, 14 and 15 depict collet core 20. Proximal end 94 of collet core 20 contains longitudinally oriented, centered slit 96 positioned transverse to the wider dimension of bore 24. Collet core 20 has collet core bore 24 that has a greater height (in FIG. 14) than width and may be oval as shown, rectangular or another appropriate shape that confines side-to-side bar movement along slit 96 and permits such movement

transverse to slit 96. Collet 22 is depicted in FIGS. 16, 17 and 18. FIGS. 16 and 18 show threads 98 on collet 22.

Retraction of blade bar 44 secures blade 50 by positioning distal end 100 of blade 50 within slit 96 of collet core 20, so that blade 50 is held in place on blade bar 44. Blade bar angle 79 allows blade 50 to be inserted and removed from blade bar 44 when the handle is in an extended position, and holds blade 50 in place, coaxial with or parallel to the longitudinal axis of the handle, upon retraction. As can best be seen in FIGS. 6 and 7, blade bar 44 is bent so that proximal end 42 is at an acute angle 79 relative to distal end 52 (and the longitudinal axis 51 of the button assembly 78 and scalpel assembly 86). Groove 46 is positioned at an acute angle 81 (at least approximately equal to angle 79) relative to the tang face 83 of blade bar 44. This causes blade 50 to be at least approximately coaxial with the longitudinal axis of scalpel assembly 86 when blade 50 is secured in scalpel handle assembly 86.

Collet core 20 has slit 96, which traps blade 50 upon retraction. Front surfaces 21 and 23 each slope toward slit 96, thereby serving to guide distal end 52 of blade bar 44 into slit 96 when blade bar 44 retracts into collet core bore 24, drawing blade 50 back with it. The oval shape of bore 24 allows blade bar 44 to move perpendicular to slit 96 as blade bar 44 is guided into slit 96 by one or both of the pair of front surfaces 21 and 23. The slit urges the distal end of blade 50 toward blade bar 44, thereby retaining the keyed slot 48 in blade 50 on heel 45 of tang 47. Tapered coiled spring 56 retracts the blade bar 44, securing blade 50 in the scalpel assembly 86 while the flared larger diameter end of spring 58 permits the above-described lateral movement of blade bar 44.

Blade 50 may be released with one hand by pressing of button 76. Depression of button 76 forces blade bar 44 out of proximal end 94 of collet core 20 so that blade 50 is discharged from slit 96 in collet core 20 and blade 50 disengages from blade bar 44. This allows easy installation and push button ejection of blade 50.

This invention may be formed from any durable metals, including aluminum, stainless steel, and autoclavable plastics. The scalpel may be made in any desired size, although typical handle lengths range between 3.5 and 6 inches and typical handle diameters range between .330 and .750 inch. The shape of the handle may vary from full round to oval or multi-faceted shapes in order to suit a range of ergonomic considerations.

FIG. 19 depicts an alternative push rod 102, for use in the scalpel assembly of this invention. FIG. 20 depicts an alternative button 104, for use in the scalpel assembly of this invention. FIG. 21 depicts an alternative button retainer 106 for use in the scalpel assembly of this invention.

5 The invention has been described by reference to specific embodiments, but is not limited to these embodiments. The invention extends to all variations and equivalents thereof within the scope of the following claims, as would be apparent to those of skill in the art.

1

THE CLAIMS:

1. A handle assembly for a detachable scalpel blade having a distal and proximal end and a keyed slot, the handle assembly comprising:
 - (a) a handle body having a longitudinal axis,
 - (b) a blade bar having a portion protruding from the handle body for engaging the blade and urging the distal end of the blade into engagement with the handle body further comprising; and
 - (c) a spring for urging the bar into the handle body.
2. The handle assembly of claim 1 wherein the blade is received in a groove in the protruding portion of the bar.
3. The handle assembly of claim 1, wherein the spring comprises a coiled spring.
4. The handle assembly of claim 2, wherein the bar is bent and the groove is approximately parallel to the longitudinal axis.
5. The handle assembly according to any one of claims 1 to 4 further comprising a collet.
6. The handle assembly according to claim 5, wherein the collet further comprises a through bore within which the blade bar is disposed.
7. The handle assembly of claim 6 wherein the collet has a slit within which an end of the blade is received.
8. The handle assembly of claim 6 or 7, wherein the collet has at least one sloping face for guiding the blade into the slit.
9. The handle assembly of claim 8, wherein the collet has a pair of faces sloping toward the slit for guiding the blade end into the slit.
10. The handle assembly of any one of claims 6 to 9, wherein the collet bore is sized and shaped to permit the bar to move laterally along one axis orthogonal to the longitudinal axis.
11. The handle assembly of any one of claims 6 to 9, wherein the collet bore has a generally oval cross-sectional shape so that the bar can move laterally within the bore along one axis orthogonal to the longitudinal axis.

12. The handle assembly of any one of claims 1 to 11, wherein the blade bar is coupled to a rod and an actuator for urging the protruding portion of the blade bar out of the handle assembly for removing the blade from the blade bar or mounting the blade on the blade bar.
13. The handle assembly of claim 12 wherein the rod extends through the coiled spring.
14. The handle assembly of claim 13 wherein an end of the coiled spring engages the collet.
15. The handle assembly of claim 12, wherein the actuator is a button attached to the rod attached to the bar.
16. The handle assembly of claim 15, wherein the rod has two ends and the bar attaches to one end and the button attaches to the other end.
17. The handle assembly of claim 1, wherein the handle body further comprises:
a handle grip,
a collet having a proximal end, and
a collet core.
18. The handle assembly of claim 14 or 17, where the handle body, the collet and collet core are formed as a single unit.
19. The handle assembly of claim 17 or 18, wherein the handle grip further comprises ribs.
20. The handle assembly of claim 17 or 18, wherein the collet flares at its proximal end.
21. The handle assembly of any one of claims 1, 13, 16 or 17 further comprising retaining means at an end of the handle body remote from the blade for capturing the blade bar within the handle body.
22. The handle assembly of claim 15, further comprising a retainer for capturing the rod within the handle body.
23. The handle assembly of claim 22, wherein the retainer is attached to the handle body with mating threads.
24. The handle assembly according to any one of claims 1 to 23, wherein the blade bar further comprises a tang for insertion in the keyed slot.

25. The handle assembly of claim 24, wherein the tang is defined by a groove and a heel.

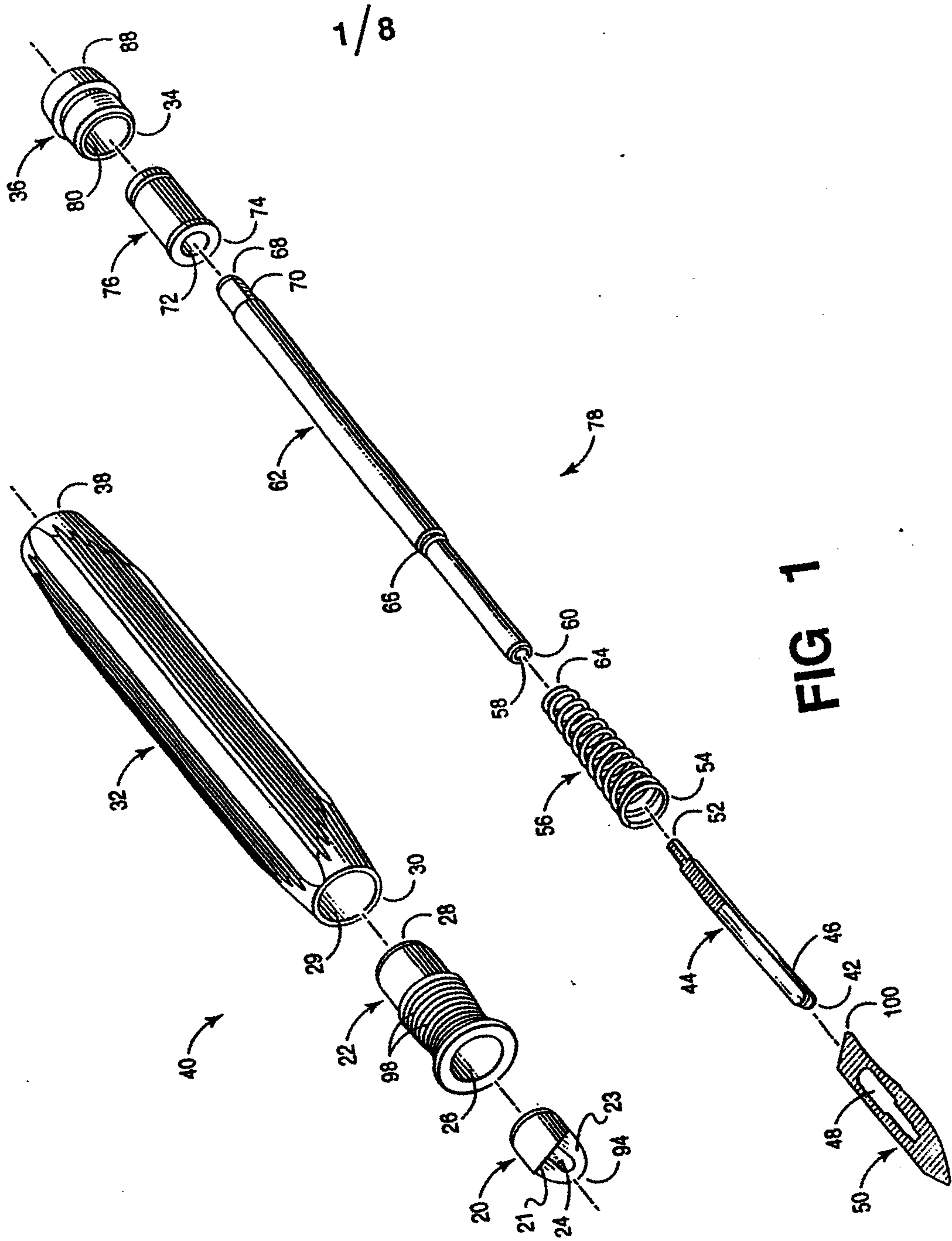

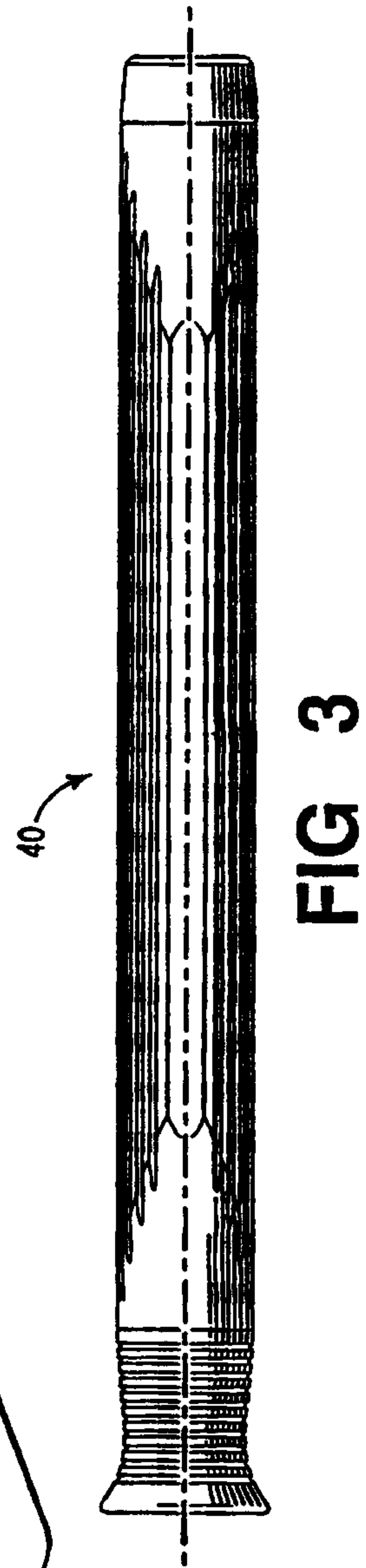
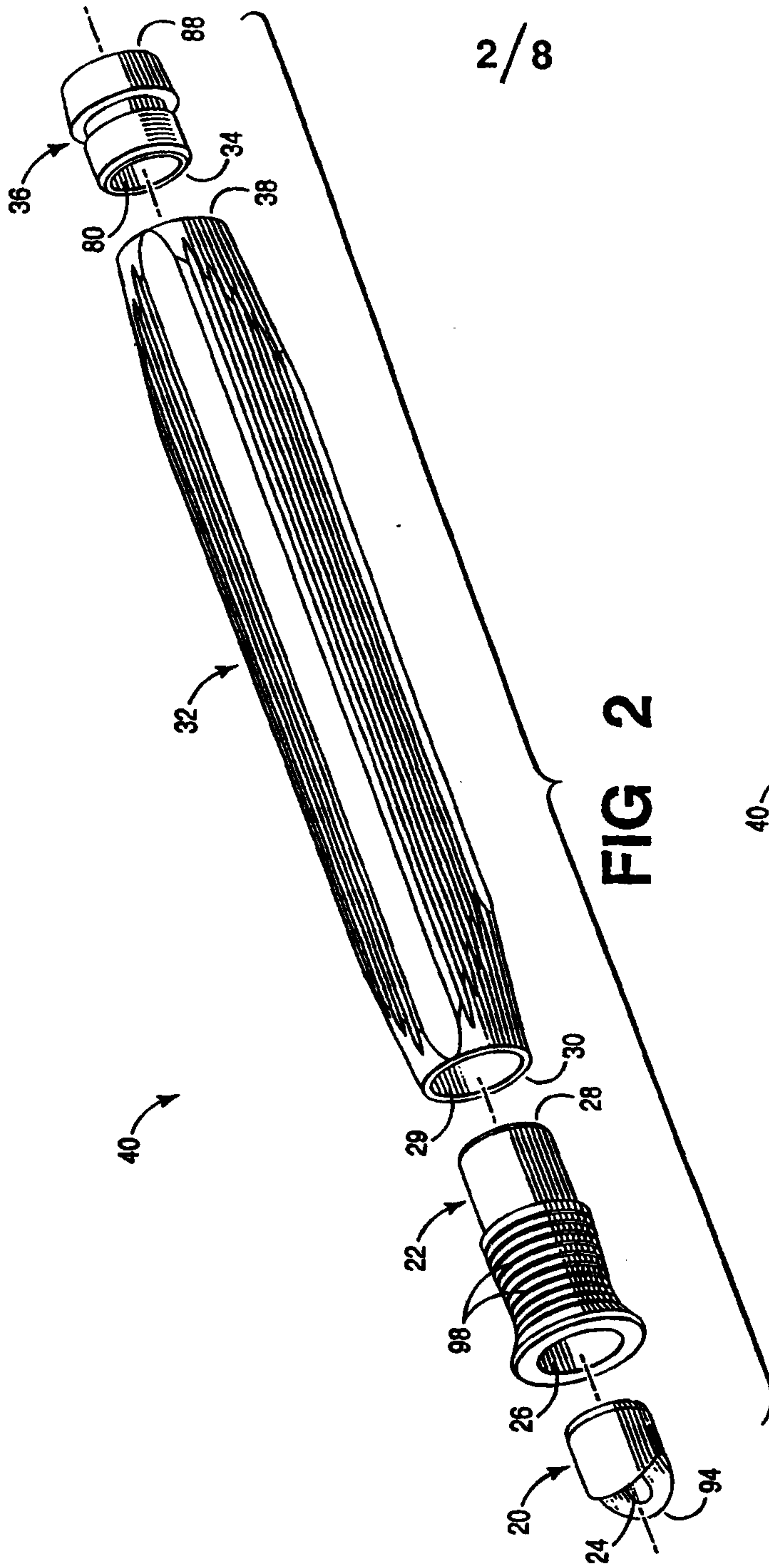

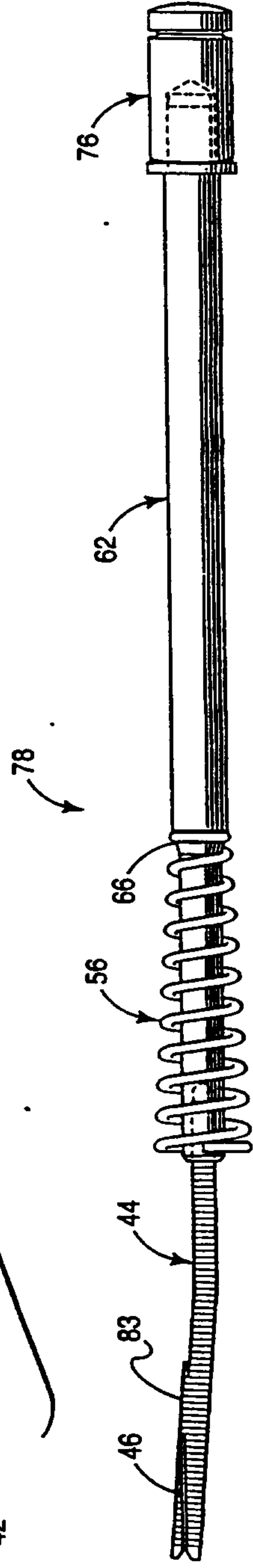
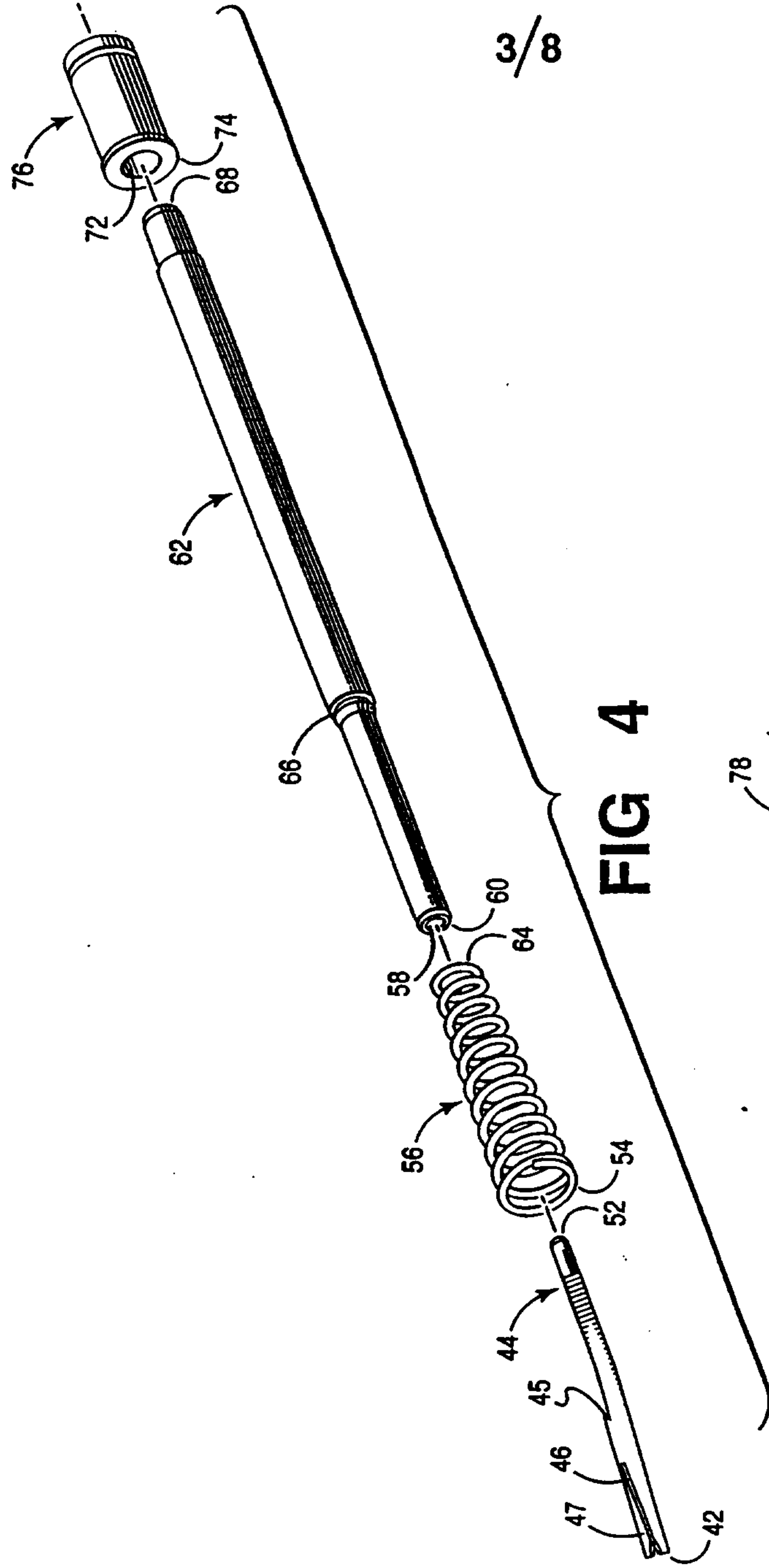

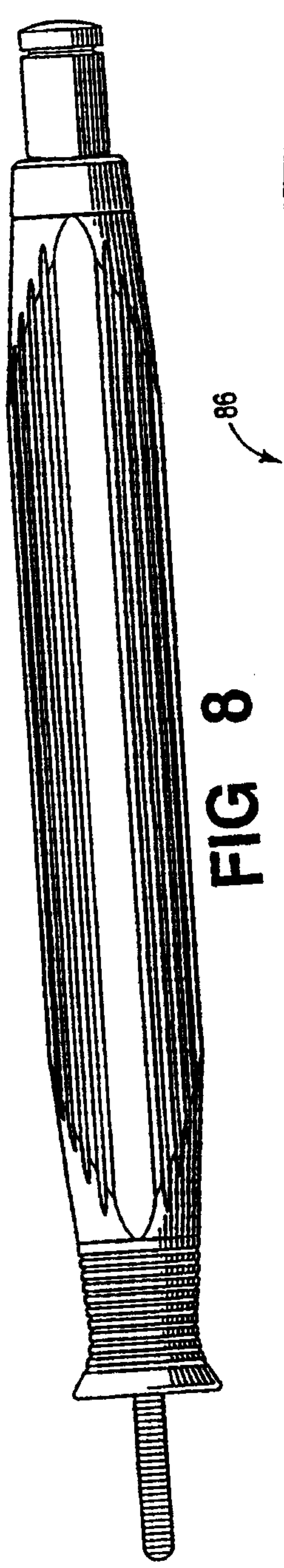
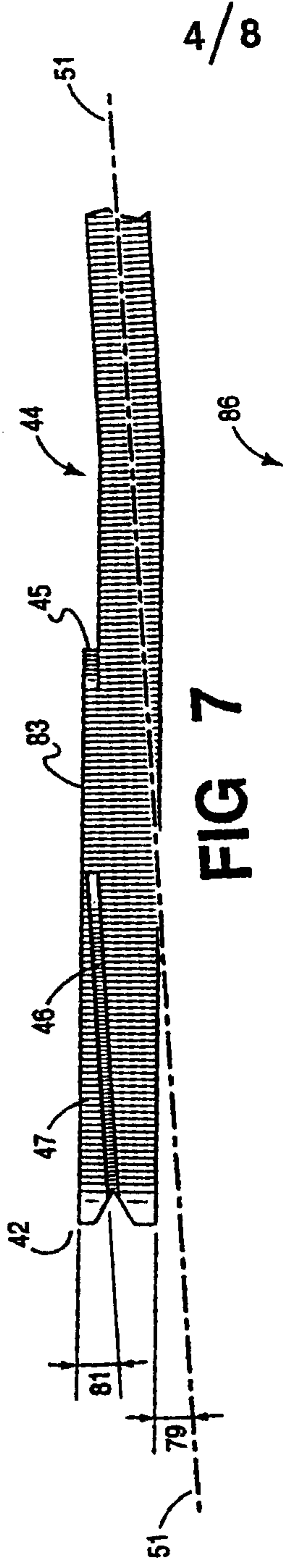
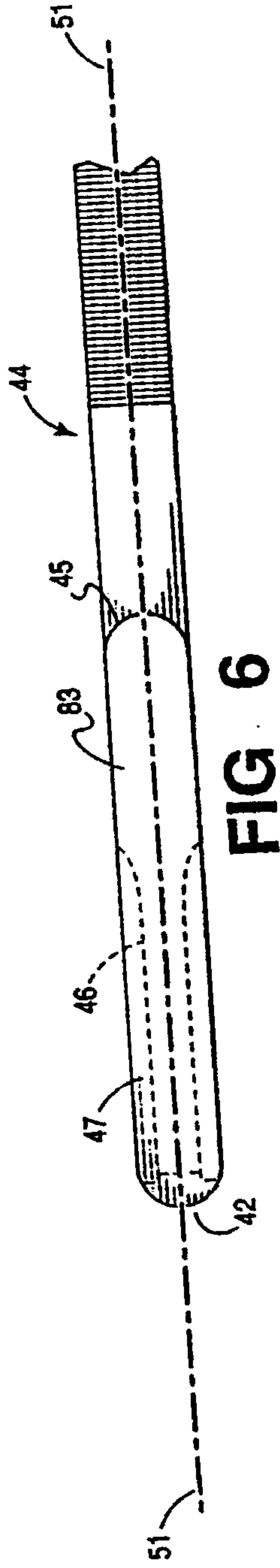

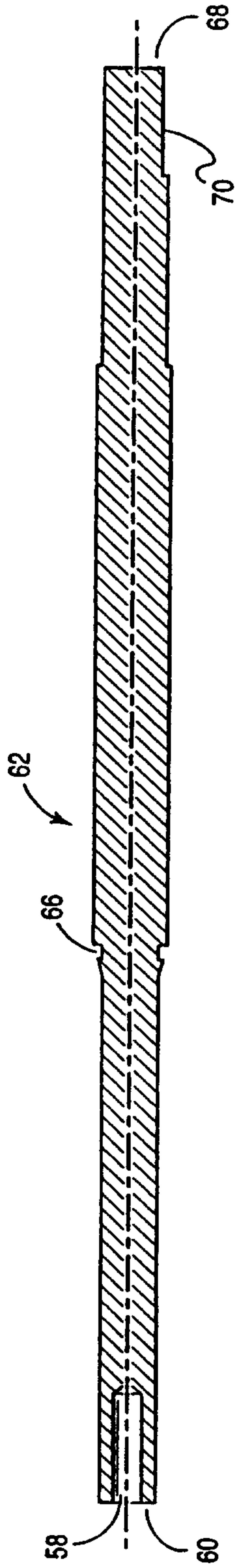

FIG 10

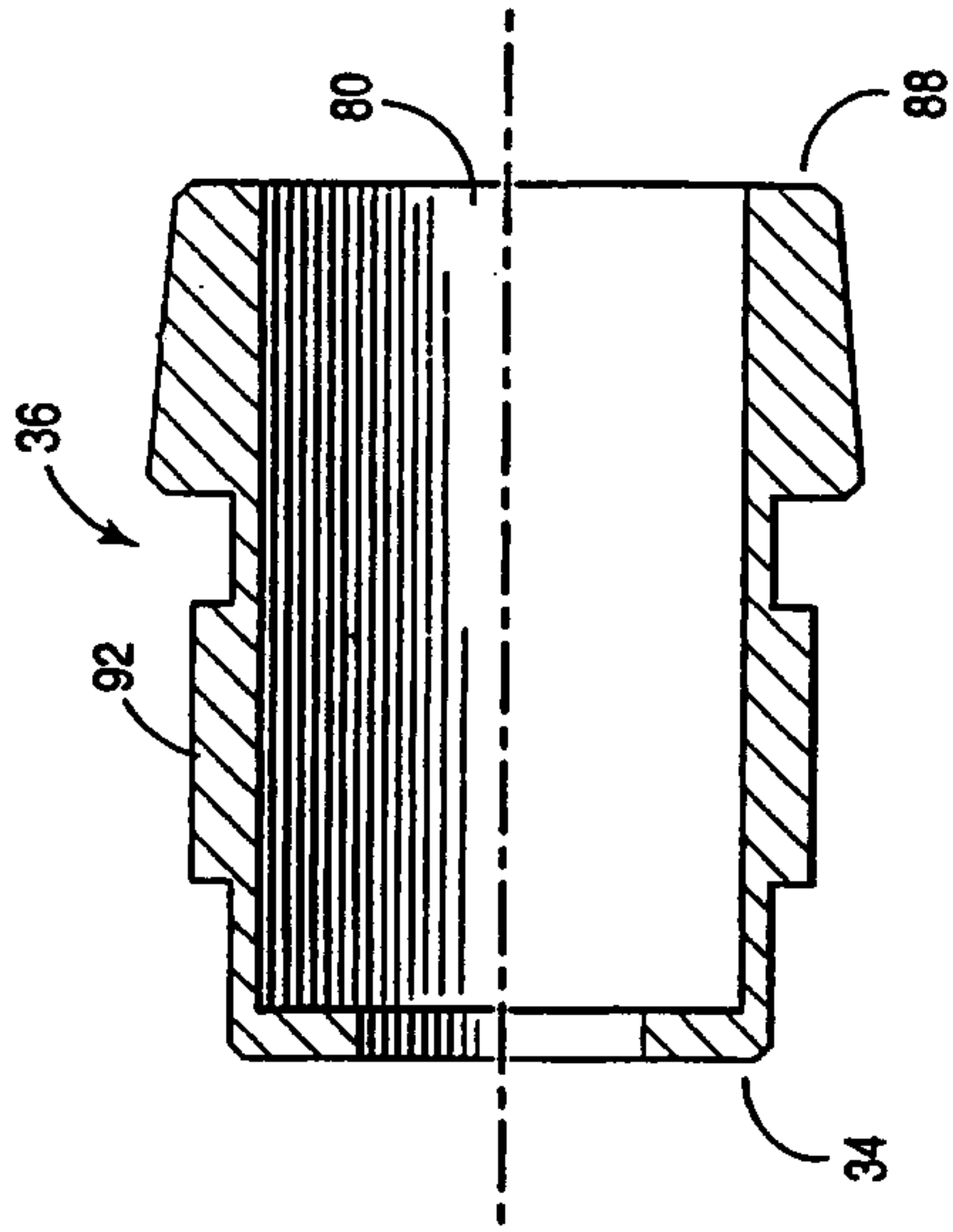

FIG 11

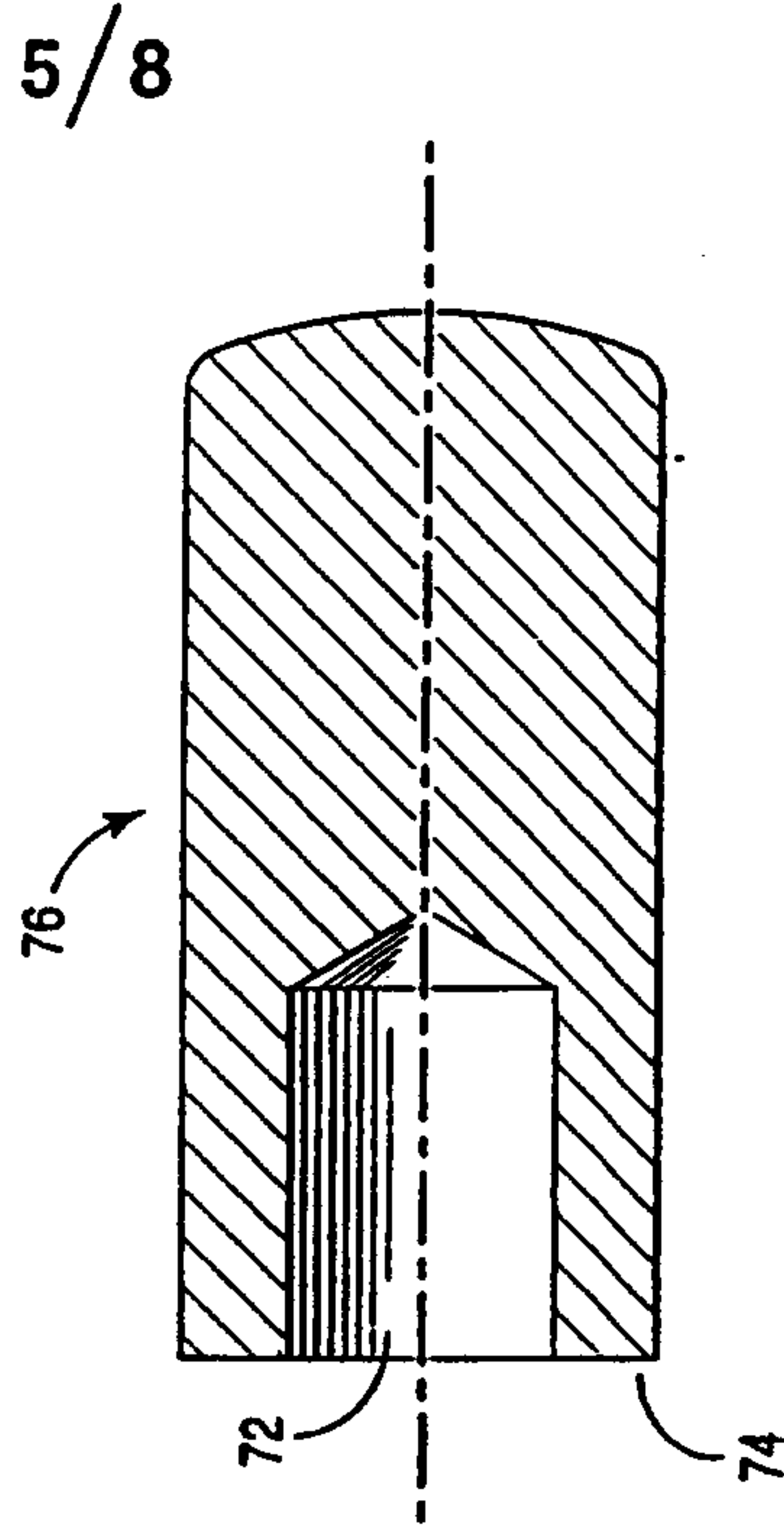

FIG 12

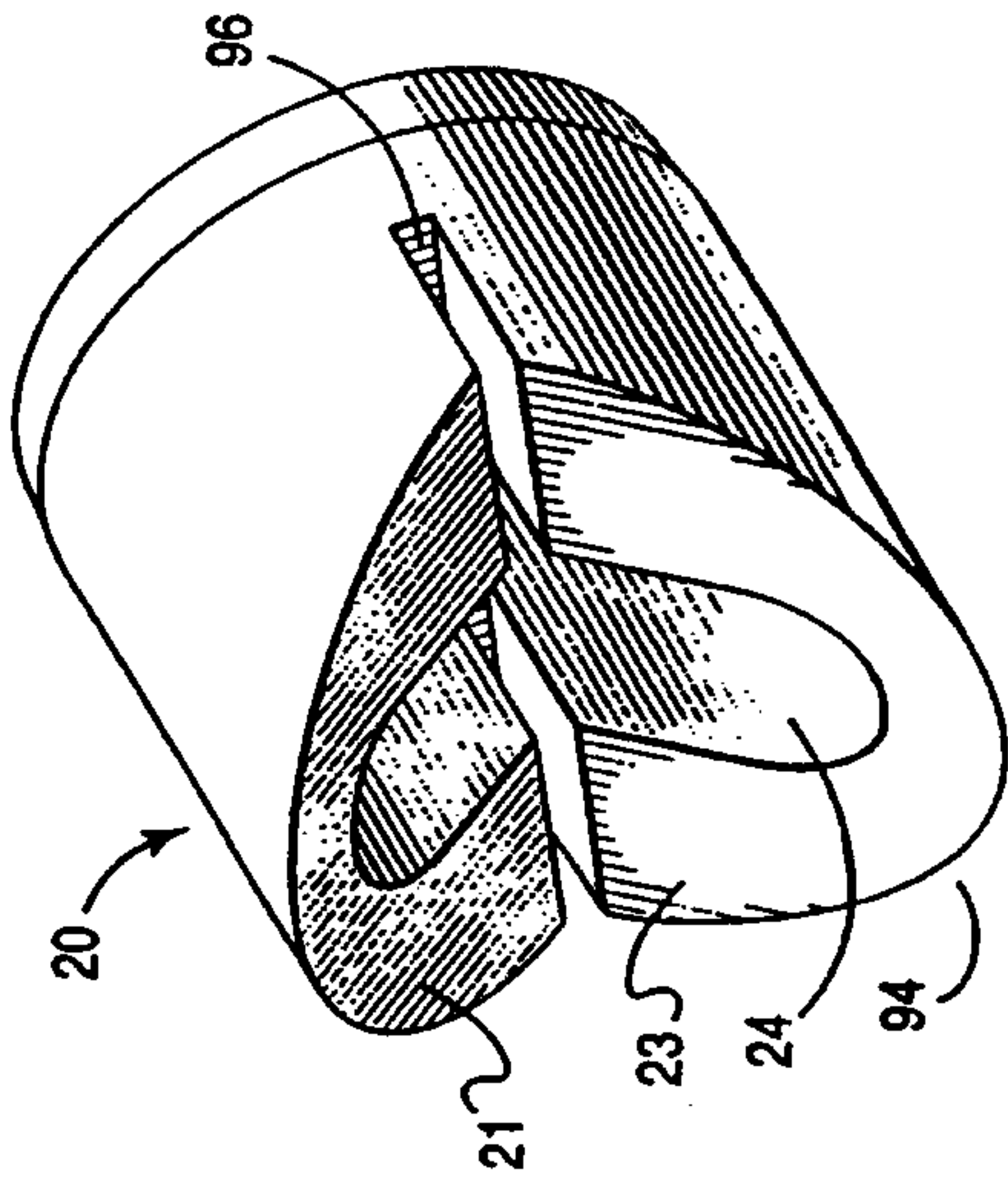

FIG 13

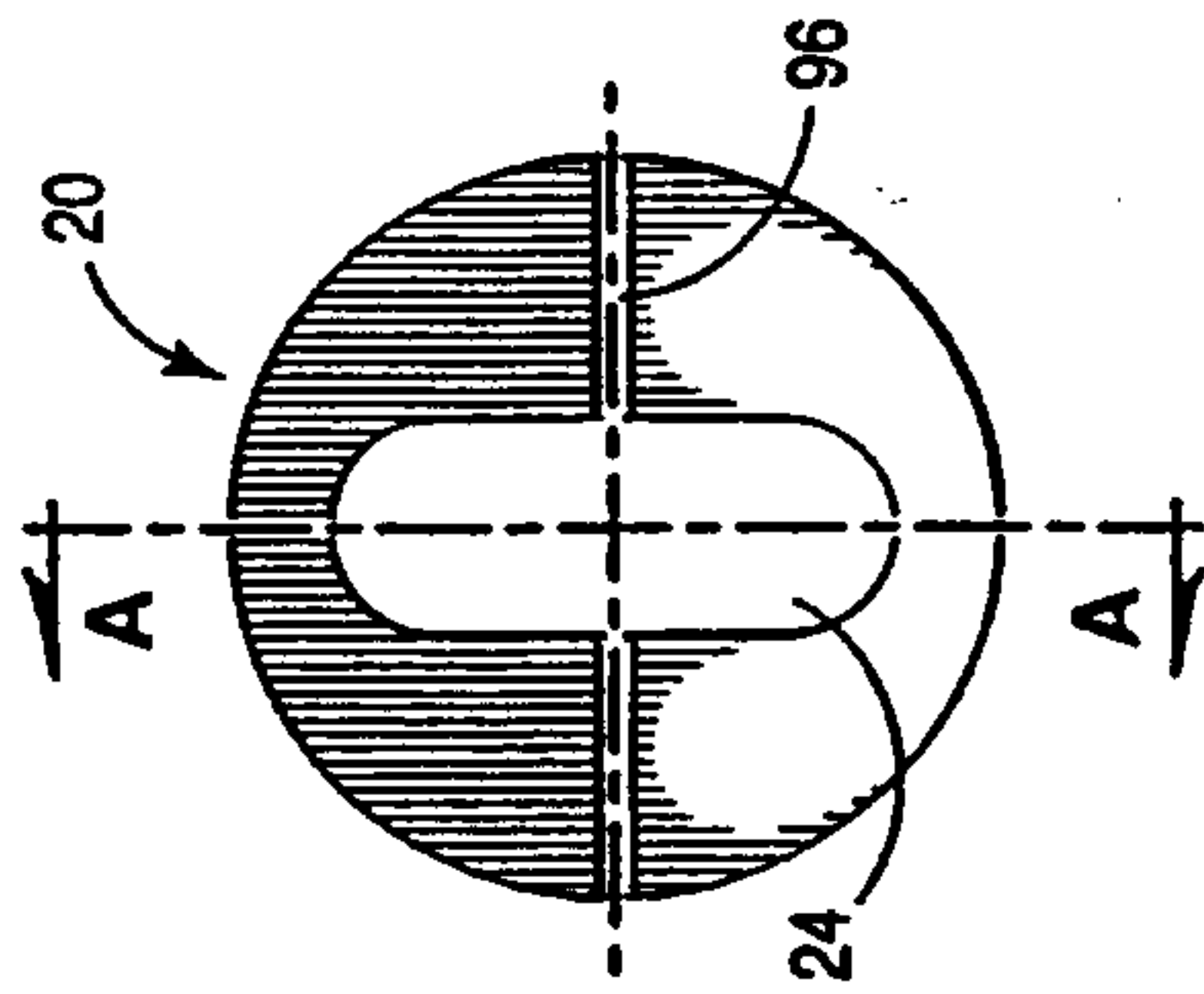

FIG 14

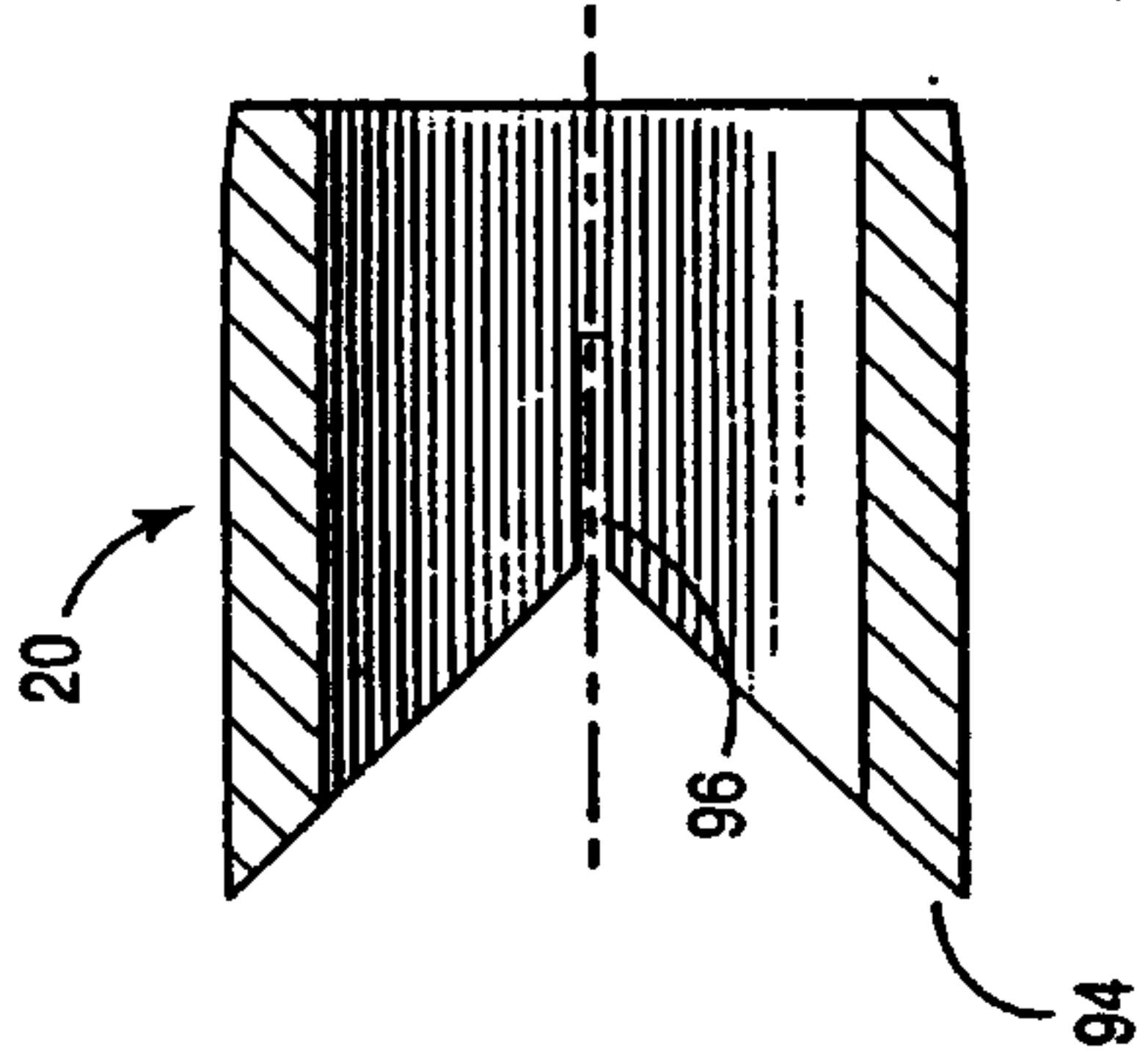

FIG 15

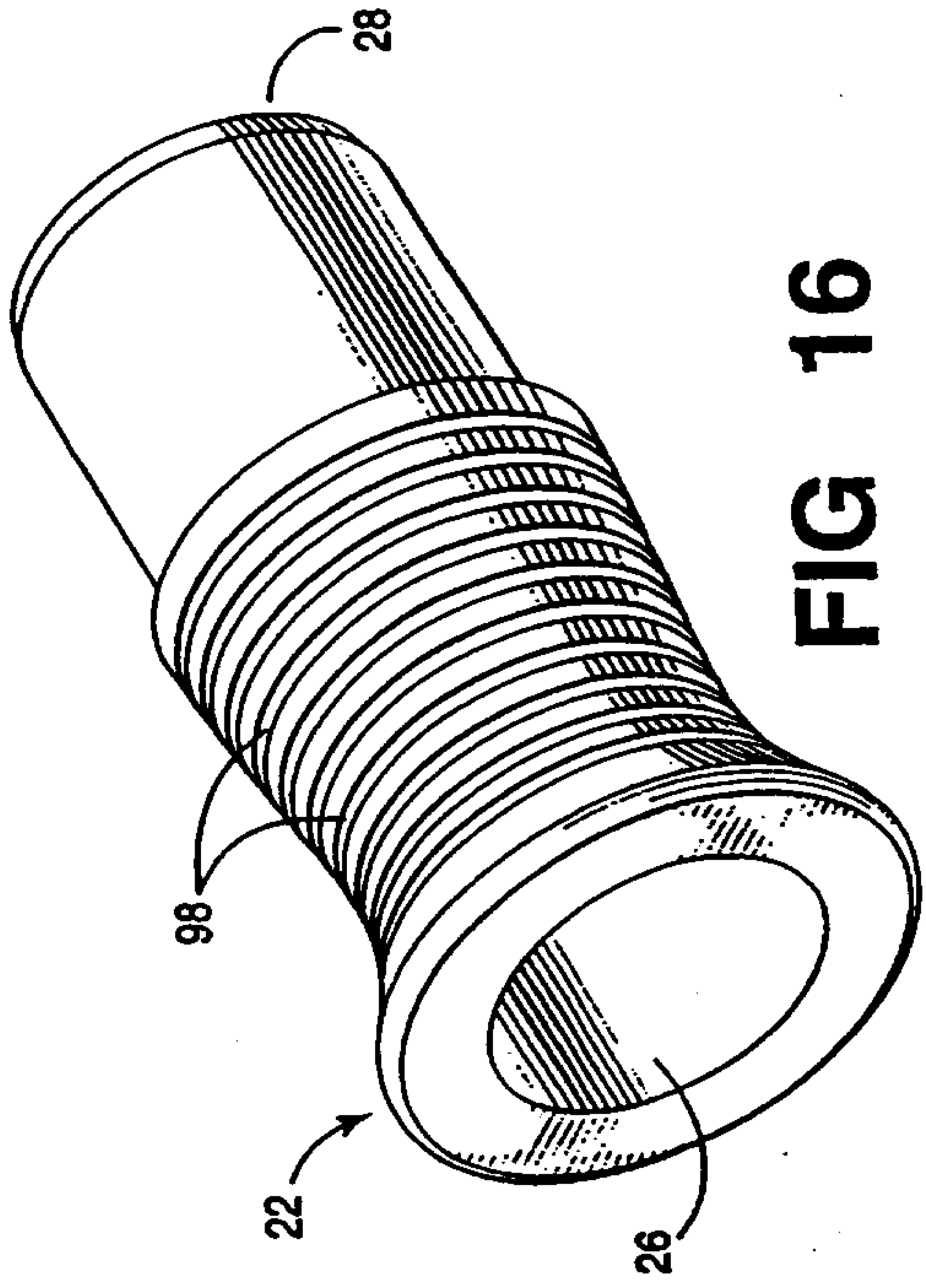

FIG 16

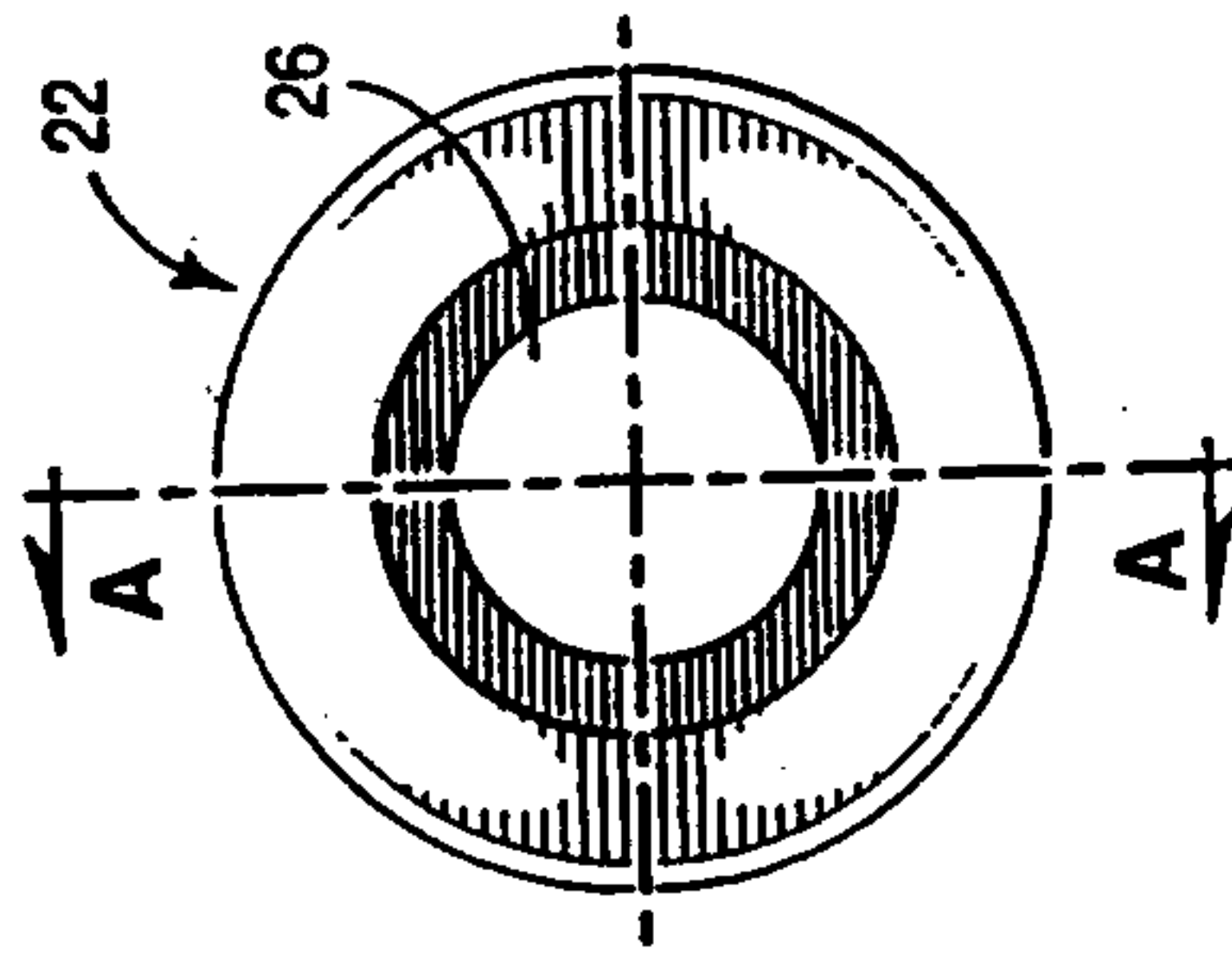

FIG 17

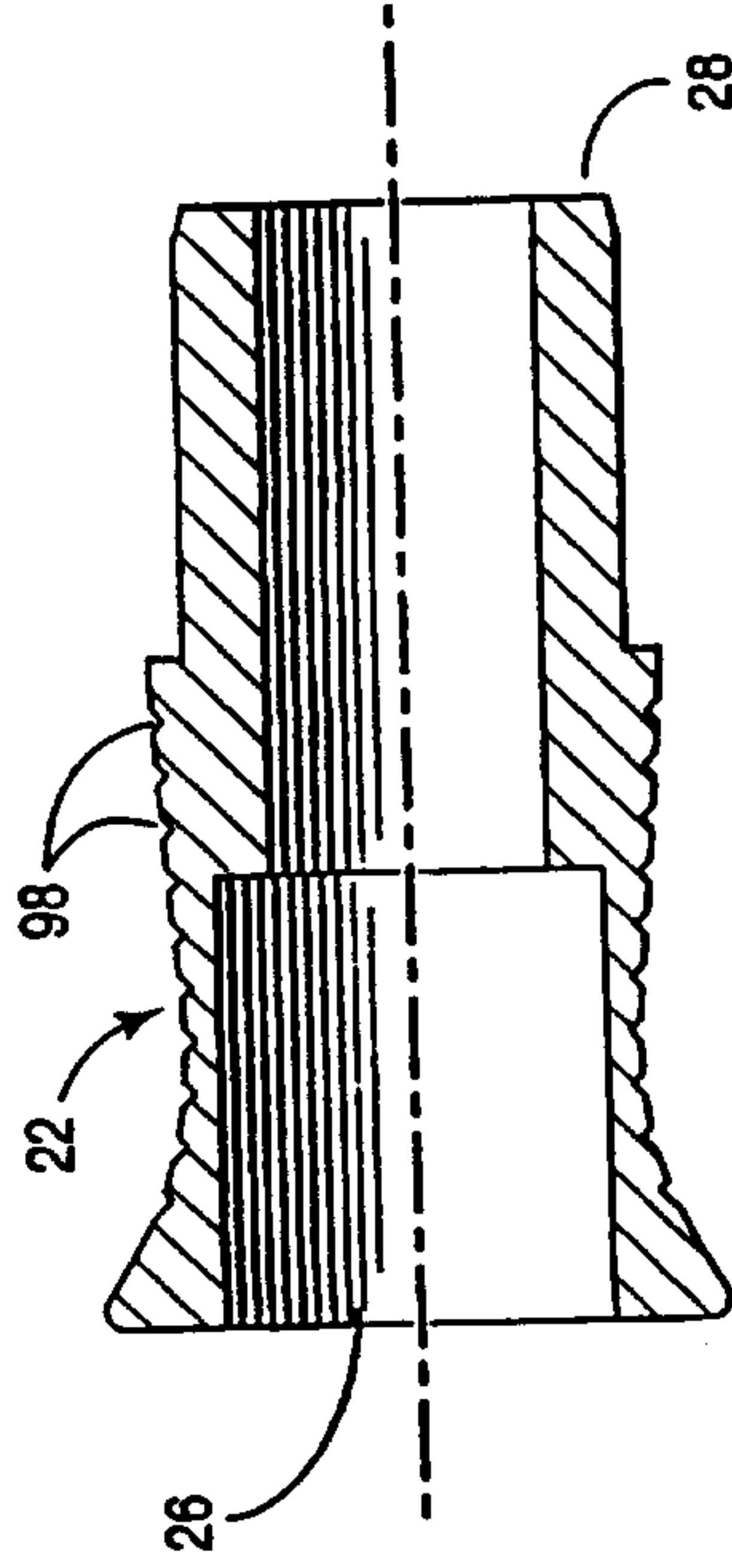

FIG 18

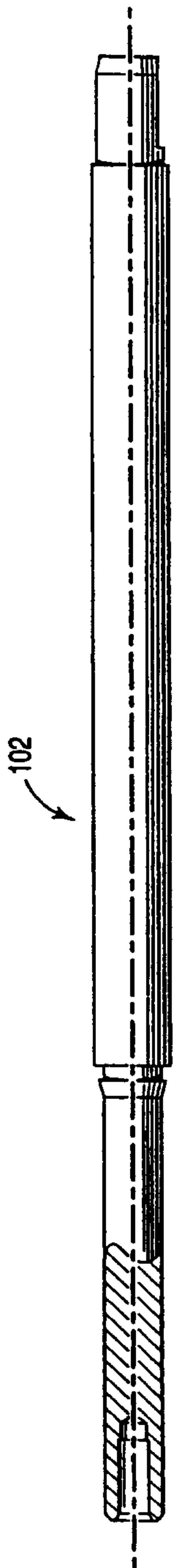

FIG 19

8/8

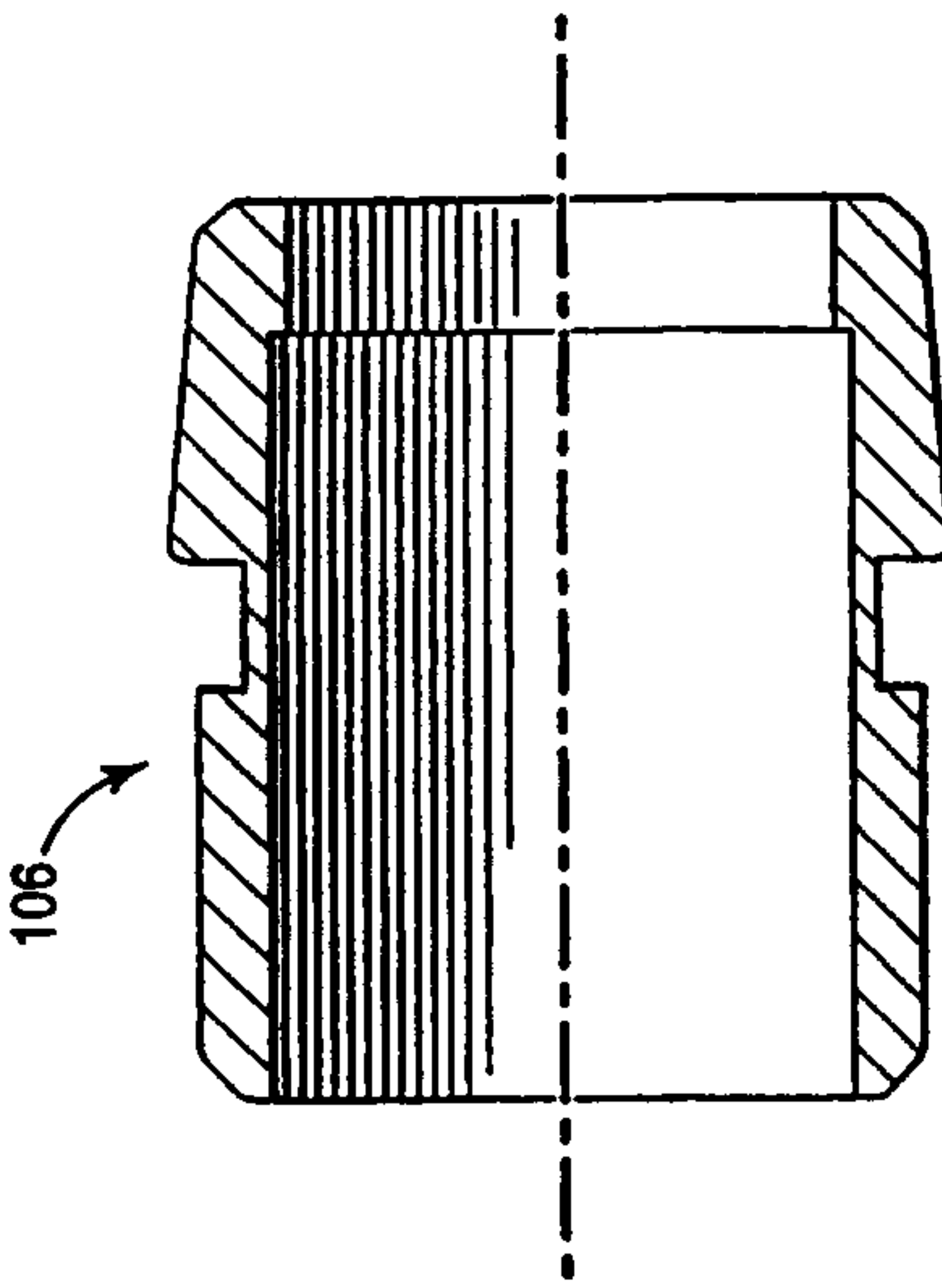

FIG 21

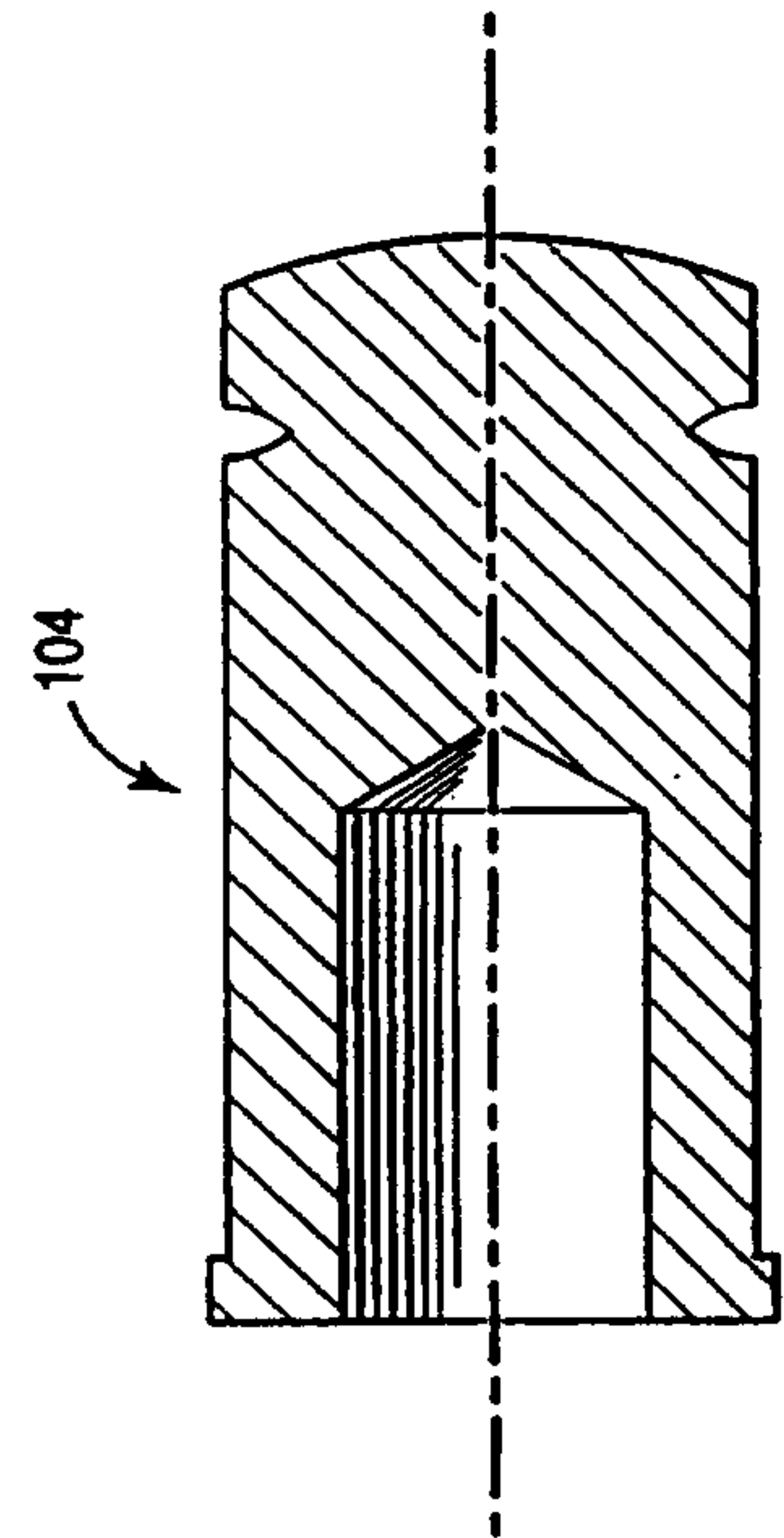

FIG 20

