

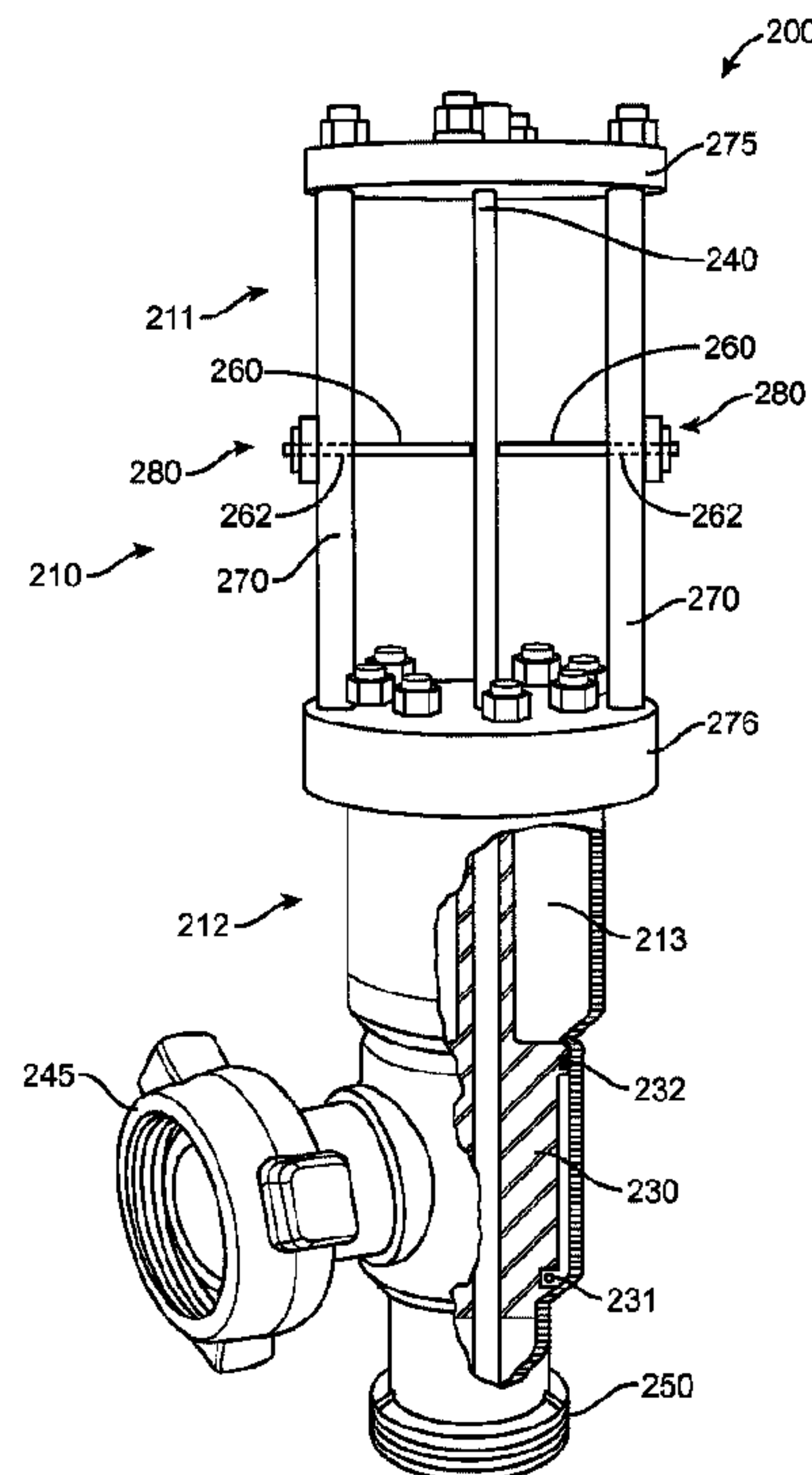

(86) Date de dépôt PCT/PCT Filing Date: 2014/08/27  
 (87) Date publication PCT/PCT Publication Date: 2016/03/03  
 (45) Date de délivrance/Issue Date: 2019/01/29  
 (85) Entrée phase nationale/National Entry: 2016/12/08  
 (86) N° demande PCT/PCT Application No.: US 2014/052942  
 (87) N° publication PCT/PCT Publication No.: 2016/032459

(51) Cl.Int./Int.Cl. *E21B 34/02* (2006.01),  
*E21B 43/12* (2006.01), *F16K 17/00* (2006.01)  
 (72) Inventeur/Inventor:  
GARDINER, NICHOLAS HUBERT, US  
 (73) Propriétaire/Owner:  
HALLIBURTON ENERGY SERVICES, INC., US  
 (74) Agent: PARLEE MCLAWS LLP

(54) Titre : SOUPAPE DE SECURITE DE LIBERATION DE PRESSION AJUSTABLE  
 (54) Title: ADJUSTABLE RELEASE PRESSURE RELIEF VALVE



(57) Abrégé/Abstract:

An adjustable release pressure relief valve including a housing having an inlet and a relief outlet connected by a fluid flow passageway, the inlet fluidly connectible to a work string. A head is sealingly disposed within the passageway between the inlet and relief outlet closing the fluid flow passageway between the inlet and relief outlet. An elongate buckling rod supports the head and is bucklable at a predetermined load thereby permitting sliding of the head from between the inlet and a relief outlet and opening the fluid flow passageway. A lateral support projection is extendable within the housing to buttress the buckling rod along the longitudinal length of the buckling rod thereby increasing the load at which the buckling rod is collapsible.

(12) INTERNATIONAL APPLICATION PUBLISHED UNDER THE PATENT COOPERATION TREATY (PCT)

(19) World Intellectual Property  
Organization  
International Bureau(10) International Publication Number  
**WO 2016/032459 A1**(43) International Publication Date  
3 March 2016 (03.03.2016)

## (51) International Patent Classification:

*E21B 34/02* (2006.01)      *F16K 17/00* (2006.01)  
*E21B 43/12* (2006.01)

## (21) International Application Number:

PCT/US2014/052942

## (22) International Filing Date:

27 August 2014 (27.08.2014)

## (25) Filing Language:

English

## (26) Publication Language:

English

(71) Applicant: **HALLIBURTON ENERGY SERVICES, INC.** [US/US]; 3000 N. Sam Houston Parkway E., Houston, Texas 77032 (US).

(72) Inventor: **GARDINER, Nicholas Hubert**; 2615 Barclay Lake Lane, Spring, Texas 77388 (US).

(74) Agents: **BRYAN, Jason W.** et al.; Novak Druce Connolly Bove + Quigg LLP, 1000 Louisiana Street, Fifty-Third Floor, Houston, Texas 77002 (US).

(81) Designated States (unless otherwise indicated, for every kind of national protection available): AE, AG, AL, AM, AO, AT, AU, AZ, BA, BB, BG, BH, BN, BR, BW, BY, BZ, CA, CH, CL, CN, CO, CR, CU, CZ, DE, DK, DM, DO, DZ, EC, EE, EG, ES, FI, GB, GD, GE, GH, GM, GT, HN, HR, HU, ID, IL, IN, IR, IS, JP, KE, KG, KN, KP, KR, KZ, LA, LC, LK, LR, LS, LT, LU, LY, MA, MD, ME, MG, MK, MN, MW, MX, MY, MZ, NA, NG, NI, NO, NZ, OM, PA, PE, PG, PH, PL, PT, QA, RO, RS, RU, RW, SA, SC, SD, SE, SG, SK, SL, SM, ST, SV, SY, TH, TJ, TM, TN, TR, TT, TZ, UA, UG, US, UZ, VC, VN, ZA, ZM, ZW.

(84) Designated States (unless otherwise indicated, for every kind of regional protection available): ARIPO (BW, GH, GM, KE, LR, LS, MW, MZ, NA, RW, SD, SL, ST, SZ, TZ, UG, ZM, ZW), Eurasian (AM, AZ, BY, KG, KZ, RU, TJ, TM), European (AL, AT, BE, BG, CH, CY, CZ, DE, DK, EE, ES, FI, FR, GB, GR, HR, HU, IE, IS, IT, LT, LU, LV, MC, MK, MT, NL, NO, PL, PT, RO, RS, SE, SI, SK, SM, TR), OAPI (BF, BJ, CF, CG, CI, CM, GA, GN, GQ, GW, KM, ML, MR, NE, SN, TD, TG).

[Continued on next page]

## (54) Title: ADJUSTABLE RELEASE PRESSURE RELIEF VALVE

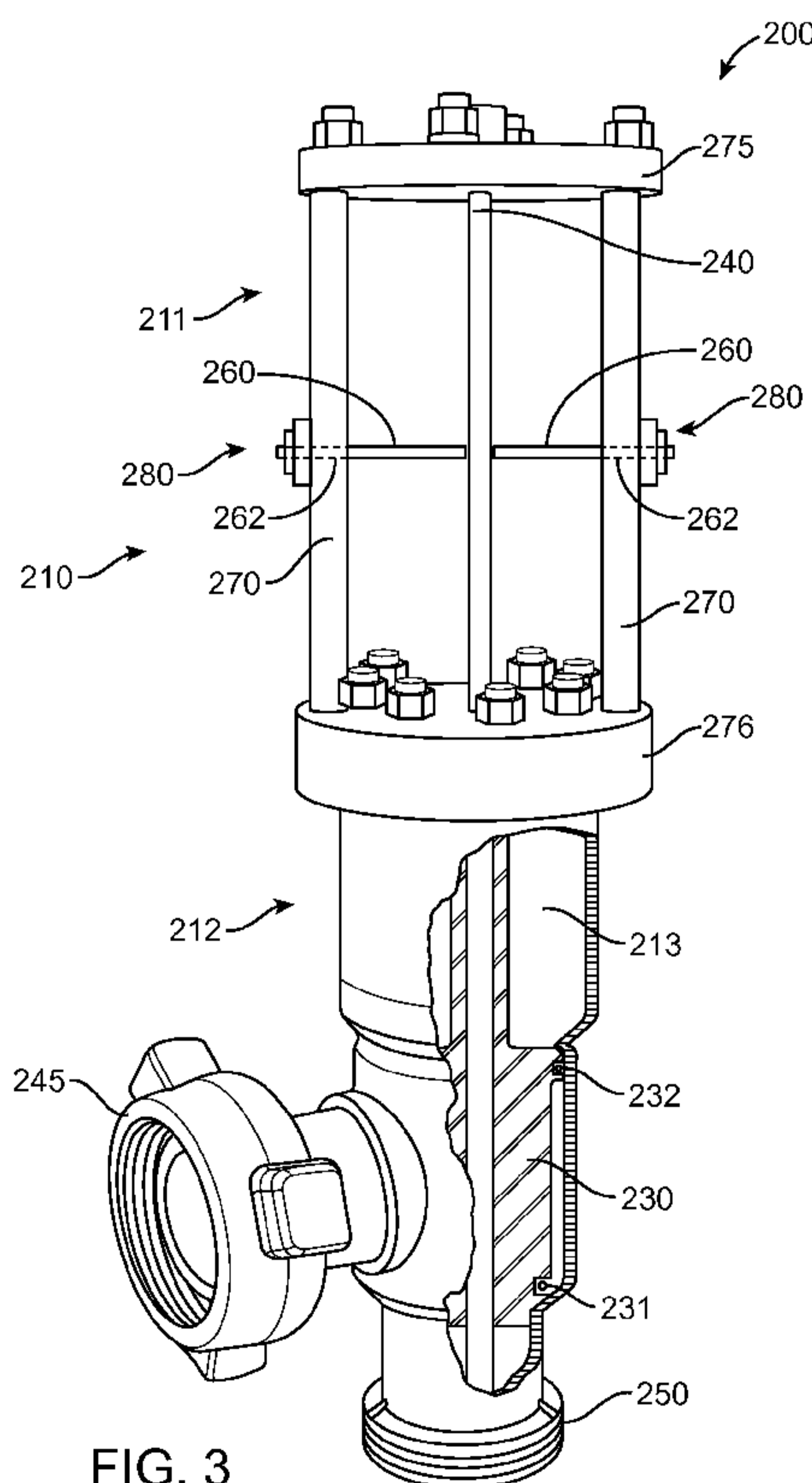

FIG. 3

(57) Abstract: An adjustable release pressure relief valve including a housing having an inlet and a relief outlet connected by a fluid flow passageway, the inlet fluidly connectible to a work string. A head is sealingly disposed within the passageway between the inlet and relief outlet closing the fluid flow passageway between the inlet and relief outlet. An elongate buckling rod supports the head and is bucklable at a predetermined load thereby permitting sliding of the head from between the inlet and a relief outlet and opening the fluid flow passageway. A lateral support projection is extendable within the housing to buttress the buckling rod along the longitudinal length of the buckling rod thereby increasing the load at which the buckling rod is collapsible.

**WO 2016/032459 A1** 

---

**Declarations under Rule 4.17:**

— *of inventorship (Rule 4.17(iv))*

**Published:**

— *with international search report (Art. 21(3))*

## ADJUSTABLE RELEASE PRESSURE RELIEF VALVE

### FIELD

[0001] The present disclosure relates generally to pumping systems involved in oil and gas exploration and production operations, and in particular to pressure control safety features.

### BACKGROUND

[0002] Oil and gas operations involve drilling deep within subterranean formations to access hydrocarbon reserves. There are many phases during such operations, including drilling, casing the wellbore, fracturing, removal of hydrocarbons, water flooding, as well as numerous other activities during the life and course of the wellbore. Involved in these phases is the need to pump various fluids down into the wellbore for a variety of reasons, depending on the phase and required needs of the project.

[0003] The pumping of these various fluids requires surface equipment including pumps, pipes, valves and other components used to complete the piping system, as well as downhole components. During pumping operations, inevitably high pressures are often reached within the system. Such high pressures can create life threatening safety hazards. For example if any of the pumping components fail as pressure exceeds safe levels, the contents under pressure or the failed components could cause harm to workers within the vicinity or result in damaged equipment.

[0004] In an effort to avoid such excessive pressure conditions, pressure relief valves have been employed, which upon reaching a particular pressure threshold provide a relief outlet for the fluid so as to prevent potentially dangerous pressure conditions.

**BRIEF DESCRIPTION OF THE DRAWINGS**

[0005] Implementations of the present technology will now be described, by way of example only, with reference to the attached figures, wherein:

[0006] FIG. 1 is a diagram illustrating an example of a fracturing system that employs an adjustable pressure relief valve in accordance with the present disclosure;

[0007] FIG. 1A is a diagram illustrating an exemplary environment for a pumping system that employs an pressure relief valve in accordance with the present disclosure;

[0008] FIG. 2 is a diagram illustrating a fracturing system employing an adjustable pressure relief valve in accordance with the present disclosure;

[0009] FIG. 3 is a diagram illustrating an adjustable pressure relief valve in accordance with the present disclosure;

[0010] FIG. 3A is a diagram illustrating an adjustable pressure relief valve having two lateral support projections in accordance with the present disclosure;

[0011] FIG. 3B is a diagram illustrating an adjustable pressure relief valve having three lateral support projections in accordance with the present disclosure;

[0012] FIG. 3C is a diagram illustrating an adjustable pressure relief valve having four lateral support projections in accordance with the present disclosure;

[0013] FIG. 3D is a diagram illustrating an adjustable pressure relief valve having four lateral support projections in accordance with the present disclosure;

[0014] FIG. 4 is a diagram illustrating an adjustable pressure relief valve coupled to a pressurized system in accordance with the present disclosure;

[0015] FIG. 5 is a diagram illustrating certain components of an adjustable pressure relief valve in accordance with the present disclosure;

[0016] FIG. 6 is a diagram illustrating certain components of an adjustable pressure relief valve in accordance the present disclosure;

[0017] FIG. 7 is a diagram illustrating certain components of an adjustable pressure relief valve in accordance with the present disclosure;

[0018] FIG. 8 is a diagram illustrating certain components of an adjustable pressure relief valve in accordance with the present disclosure; and

[0019] FIG. 9 is a schematic of an exemplary system controller for having a processor suitable for use in the methods and systems disclosed herein.

[0020] It should be understood that the various embodiments are not limited to the arrangements and instrumentality shown in the drawings.

#### DETAILED DESCRIPTION

[0021] It will be appreciated that for simplicity and clarity of illustration, where appropriate, reference numerals have been repeated among the different figures to indicate corresponding or analogous elements. In addition, numerous specific details are set forth in order to provide a thorough understanding of the embodiments described herein. However, it will be understood by those of ordinary skill in the art that the embodiments described herein can be practiced without these specific details. In other instances, methods, procedures and components have not been described in detail so as not to obscure the related relevant feature being described. Also, the description is not to be considered as limiting the scope of the embodiments described herein. The drawings are not necessarily to scale and the proportions of certain parts have been exaggerated to better illustrate details and features of the present disclosure.

[0022] In the following description, terms such as "upper," "upward," "lower," "downward," "above," "below," "downhole," "uphole," "longitudinal," "lateral," and the like, when used in relation to orientation within a wellbore, shall mean in relation to the bottom or furthest extent of, the surrounding wellbore even though the wellbore or portions of it may be deviated or horizontal. Correspondingly, the transverse, axial, lateral, longitudinal, radial, and the like orientations shall mean positions relative to the orientation of the wellbore or tool.

[0023] Several definitions that apply throughout this disclosure will now be presented. The term "coupled" is defined as connected, whether directly or indirectly through intervening components, and is not necessarily limited to physical connections. The connection can be such that the objects are permanently connected or releasably connected. The term "communicatively coupled" is defined as connected, either directly or indirectly through intervening components, and the connections are not necessarily limited to physical connections, but are connections that accommodate the transfer of data between the so-described components. A "processor" as used herein is an electronic circuit that can make determinations based upon inputs. A processor can include a microprocessor, a microcontroller, and a central processing unit, among others. While a single processor can be used, the present disclosure can be implemented over a plurality of processors.

[0024] The term "outside" refers to a region that is beyond the outermost confines of a physical object. The term "inside" indicates that at least a portion of a region is partially contained within a boundary formed by the object. The term "substantially" is defined to be essentially conforming to the particular dimension, shape or other thing that "substantially" modifies, such that the component need not be exact. For example, substantially cylindrical means that the object resembles a cylinder, but can

have one or more deviations from a true cylinder. The terms "comprising," "including" and "having" are used interchangeably in this disclosure. The terms "comprising," "including" and "having" mean to include, but not necessarily be limited to the things so described.

[0025] The term "radial" and/or "radially" means substantially in a direction along a radius of the object, or having a directional component in a direction along a radius of the object, even if the object is not exactly circular or cylindrical. The term "axially" means substantially along a direction of the axis of the object. If not specified, the term axially is such that it refers to the longer axis of the object. The term "formation" means the below ground level, geological structure in which hydrocarbons are located. The term "reservoir" refers to the pool of hydrocarbons within the formation. The term "overpressure condition" means pressure in excess of the maximum allowable pressure (rated working pressure) for a given component."

[0026] Disclosed herein is an adjustable release pressure relief valve. During oil and gas operations, pumping operations are often required in order to inject various fluids into a wellbore. The types of fluid depend on the particular needs or phase of the operation. For example, when installing a casing in a wellbore, cement is required to be pumped downhole between the casing and wall of the wellbore. Further, in fracturing operations, fluid containing gelling agents or proppant is pumped within the formation. Additionally, in post fracturing operations such as reservoir flooding, pumping of fluid downhole is conducted. There may be numerous operations requiring pumps and pressurized systems.

[0027] A surface work string is provided above ground on the surface, which includes pumping equipment, conveyances such as piping, tubing, lines, joints, or other components where various fluids and additives can be mixed and pumped into a downhole work string. During such pumping

operations an over pressure condition can result in the surface work string. For example if there is a blockage downhole, this can result in sudden spikes of pressure throughout the system. Such increases in pressure, whether sudden or built up over time, can result in safety hazards. For example, the surface work string including the pumping equipment can have a maximum safe pressure level above which failure can occur.

[0028] The pressures which can cause such failure can depend on the equipment used, as well as the operation and pumping equipment. Accordingly, the pressure at which failure occurs or risk of failure may vary. Therefore, disclosed herein is a pressure relief valve which can be adjusted to accommodate different overpressure conditions and provide pressure release at varying predetermined pressures.

[0029] The pressure relief valve disclosed herein includes a housing having an inlet and a relief outlet connected by a passageway for a fluid. The housing also has sealing mechanism including a head and a buckling rod which axially supports the head. The head is sealingly disposed between the inlet and outlet of the safety valve thus closing the fluid passageway. Accordingly, as fluid flows past the safety valve in the work string, fluid may enter a portion of the inlet and contact the head but be prevented from exiting the relief outlet, and thus continue on in the work string.

[0030] The buckling rod is configured to "buckle" or collapse at a particular predetermined pressure (i.e., load) imposed by fluid against the head. In particular, the pressure of the fluid in the work string presses against the head, thus providing force against the head and the buckling rod supporting the head. As the buckling rod supports the head, the buckling rod can have a particular mechanical strength in the longitudinal axial direction at which it the buckling rod fails, thus buckling. Upon buckling, the head then slides past the safety outlet thus opening the passage between the inlet and outlet. Accordingly, fluid can flow through the relief outlet and release

pressure in the system. The load at which the buckling rod ceases to be able to bear a load and buckles and collapses can be referred to as the "buckling load" of the buckling rod.

[0031] The buckling rod can be configured to buckle and collapse at any particular predetermined load (e.g. pressure, or force) imposed in the axial direction. The buckling load depends on many features: material, length, diameter or cross section size, end configuration, and manufacturing tolerances of the buckling rod. However, with all features except length held constant, the buckling load varies in relation to its length. By varying the length of the buckling rod, therefore the buckling load can be adjusted. As disclosed herein, rather than substituting out the buckling rod for another in order to achieve a different value for the buckling load, instead, lateral side projections can be extended to buttress the buckling rod along its length. By buttressing the buckling rod above its distal end, the buckling rod's effective length is shorter, thereby increasing the buckling load of the buckling rod.

[0032] For example, by buttressing the buckling rod above its distal end, for instance midway between its end points, the strength of the buckling rod, i.e. its buckling load, is increased. The lateral projections can be extended through the housing at various points along its length. Therefore, the pressure at which the pressure relief valve opens and releases pressure can be adjusted by extending and retracting lateral adjustment projections, from against the buckling rod within the housing of the pressure valve.

## Pumping system

[0033] The pressure relief valve disclosed herein can be used in with any pressurized system in order to provide safety pressure release. The pressure relief valve can be employed in connection with a work string on the surface related to an oil and gas operation. The pressure relief valve can be used in conjunction with any fluid transfer system susceptible to overpressure events, for example, this can be used in a boiler system, a compressor station, and other situations where pressure relief is potentially required. The pressure relief valve can be employed in a system having a pumping system connected with a work string extending from the surface into a drilled borehole. The pumping system on the surface can be connected to discharge equipment and related components, also referred to as discharge manifold equipment (also in the field referred to informally as "iron"), for discharging fluid into a conveyance. The discharge manifold and related equipment affects the discharge of pressurized fluid from the one or more pumps.

[0034] In some oil and gas operations there can be containers or trucks, some containing a fluid such as water or salt water as well as others having additives, such as sand, other proppant or chemical additive. The fluid can be composed of liquids, gases, slurries, foams, multiphase or other phases. For example the fluid can include a fracturing fluid, a cement, a drilling mud, nitrogen, completion brine, acid, displacement fluid, steam water, treated water, hydrocarbons, CO<sub>2</sub>, or other fluid. The water and additives can be provided to a blender which mixes the water and additive together and then provided to one or more pumps. The pumps pressurize the fluid into a distribution manifold, which then discharges the pressurized fluid into a discharge line, and further into a conveyance which passes to the downhole work string. For ease of reference the system together, including the

pumps, discharge equipment, and subsequent conveyances can be referred to as the surface work string.

[0035] The pressure relief valve can be connected anywhere along the surface work string subsequent a pump. However, the pressure relief valve may be positioned closer to the pumps, for example in the discharge line or discharge manifold or a line exiting the pump.

[0036] As described, the pressure relief valve can be employed with any pressurized system. For example, the pressure relief valve disclosed herein can be provided in relation to fracturing operations. In such operations pressures can reach several thousands of psi, and thus safety can become a concern. Pressure can reach from 600 to 20,000 psi, with pressure spikes reaching much higher than the operating range. Accordingly, the potential for equipment or systemic failure is possible. Although not restricted to such operations, one example of a pressurized system is an exemplary fracturing system 10 illustrated in FIG. 1.

[0037] In certain instances, the system 10 includes a fracturing fluid producing apparatus 20, a fluid source 30, a proppant source 40, a blender 45, a pump system 50, surface work string 55, and adjustable pressure relief valve 200 and resides at the surface at a well site where a well 60 is located. In certain instances, the fracturing fluid producing apparatus 20 combines a gel pre-cursor with fluid (e.g., liquid or substantially liquid) from fluid source 30, to produce a hydrated fracturing fluid that is used to fracture the formation. The hydrated fracturing fluid can be a fluid for ready use in a fracture stimulation treatment of the well 60 or a concentrate to which additional fluid is added prior to use in a fracture stimulation of the well 60. In other instances, the fracturing fluid producing apparatus 20 can be omitted and the fracturing fluid sourced directly from the fluid source 30. In certain instances, the fracturing fluid may comprise water, a hydrocarbon fluid, a polymer gel, foam, air, wet gases and/or other fluids.

[0038] The proppant source 40 can include a proppant for combination with the fracturing fluid. Proppant can include sand or other hard particulate matter. The system may also include additive source 70 that provides one or more additives (e.g., gelling agents, weighting agents, and/or other optional additives) to alter the properties of the fracturing fluid. For example, the other additives 70 can be included to reduce pumping friction, to reduce or eliminate the fluid's reaction to the geological formation in which the well is formed, to operate as surfactants, and/or to serve other functions.

[0039] The fracturing fluid is then passed to a blender 45 to be combined with other components, including proppant from the proppant source 40 and/or additional fluid from the additives 70 and then received by pump system 50. The resulting mixture may be pumped down the well 60 under a pressure sufficient to create or enhance one or more fractures in a subterranean zone, for example, to stimulate production of fluids from the zone. Notably, in certain instances, the fracturing fluid producing apparatus 20, fluid source 30, and/or proppant source 40 may be equipped with one or more metering devices (not shown) to control the flow of fluids, proppants, and/or other compositions to the pumping system 50. Such metering devices may permit the pumping system 50 to source from one, some or all of the different sources at a given time, and may facilitate the preparation of fracturing fluids in accordance with the present disclosure using continuous mixing or "on-the-fly" methods. Thus, for example, the pumping and blender system 50 can provide just fracturing fluid into the well at some times, just proppants at other times, and combinations of those components at yet other times.

[0040] As shown in FIG. 1, the adjustable pressure relief valve 200 can be connected to the surface work string 55, which includes pump system 50 and conveyances or lines exiting from the pump system 50. The adjustable

pressure relief valve 200 may be connected to the system at or subsequent the pump 50. The adjustable pressure relief valve 200 can also be connected to the system prior to being passed down the well 60. The work string includes conveyances such as tubular members, piping, coiled tubing, jointed pipe, and/or other structures that allow fluid to flow into the well 60.

[0041] An environmental perspective of a pumping system is shown in FIG. 1A. As shown, a fluid source 31 (such as water or salt water) may be provided to an additive unit 71, which can be add gelling agents to the fluid from fluid source 31. This can then be sent to a blender 45 which can blend the fluid with proppant from a proppant source 42. The proppant source can be for example sand or hard particulate matter. The blended fluid can then be provided to distribution manifold equipment 53 on a low pressure side 51. A series of pumps 52 can be provided on trucks which pressurize the system and pump the fluid from the high pressure side 54 of the distribution manifold 53 to the well head 61, and into the well 60. For purposes of this disclosure, the conveyances and lines from the pumps 52 to the distribution manifold 53 and to head can be referred to as a surface work string. The pressure relief valve 200 disclosed herein can be provided anywhere along the surface work string to provide pressure relief thereto.

[0042] Fig. 2 shows the well 60 during a fracturing operation as shown in FIG. 1 in a portion of a subterranean formation of interest 102 (usually having a hydrocarbon reservoir) surrounding a well bore 104. The well bore 104 extends from the surface 106, and the fracturing fluid 108 in work string 55 is applied to a portion of the subterranean formation 102 surrounding the horizontal portion of the well bore. Although shown as vertical deviating to horizontal, the well bore 104 may include horizontal, vertical, slant, curved, and other types of well bore geometries and orientations, and the fracturing treatment may be applied to a subterranean zone surrounding any portion of the well bore. The well bore 104 can include a casing 110 that is cemented

or otherwise secured to the well bore wall. The well bore 104 can be uncased or include uncased sections. Perforations can be formed in the casing 110, any cement, and into the formation to allow fracturing fluids 108 and/or other materials to flow into the subterranean formation 102. In cased wells, perforations can be formed using shape charges, a perforating gun, hydro-jetting and/or other tools.

[0043] The well is shown with a work string 112 depending from the surface 106 into the well bore 104. The pump system 50 is coupled to surface work string 55, for pumping the fracturing fluid 108 into well bore 104 via downhole work string 112. The working string 112 may include coiled tubing, jointed pipe, and/or other structures that allow fluid to flow into the well bore 104. The working string 112 can include flow control devices, bypass valves, ports, and or other tools or well devices that control a flow of fluid from the interior of the working string 112 into the subterranean zone 102. For example, the working string 112 may include ports adjacent the well bore wall to communicate the fracturing fluid 108 directly into the subterranean formation 102, and/or the working string 112 may include ports that are spaced apart from the well bore wall to communicate the fracturing fluid 108 into an annulus in the well bore between the working string 112 and the well bore wall.

[0044] The working string 112 and/or the well bore 104 may include one or more sets of packers 114 that seal the annulus between the working string 112 and well bore 104 to define an interval of the well bore 104 into which the fracturing fluid 108 will be pumped. FIG. 2 shows two packers 114, one defining an uphole boundary of the interval and one defining the downhole end of the interval. When the fracturing fluid 108 is introduced into well bore 104 (e.g., in FIG. 2, the area of the well bore 104 between packers 114) at a sufficient hydraulic pressure, one or more fractures 116 may be created in the subterranean zone 102. The proppant particulates in

the fracturing fluid 108 may enter the fractures 116 where they may remain after the fracturing fluid flows out of the well bore. These proppant particulates may "prop" fractures 116 such that fluids may flow more freely through the fractures 116.

[0045] Although a fracturing system is discussed above, the adjustable pressure relief valve 200 can be used in other operations that involved a pressurized work string or system. For example, as noted in FIG. 2, there is a casing 110 that may be cemented or otherwise secured to well bore 104. The pump 50 can pump cement mixture mixed in blender 45, and then pumped via surface work string 55 into the annulus between the well bore 104 and the casing 110. The adjustable pressure relief valve 200 can be connected to the surface work string 55 and pump system 50 for providing a safety pressure release. The adjustable pressure relief valve 200 can be used in other pressurized applications other than fracturing systems or cement operations as well.

#### Adjustable Pressure Relief Valve

[0046] The exemplary adjustable pressure relief valve 200 is illustrated in FIG. 3. As shown the relief valve 200 has a housing 210 with lower housing 211 and upper housing 212. The upper housing 212 has an inlet 245, a relief outlet 250, and an interior space 213, as well as seals 231 and 232 (FIG. 4). The inlet 245 is couplable to a surface work string and can receive fluid flow therein. The fluid can be any type of fluid flowing through the work string. For example, it can include fracturing fluid as discussed above, cement, water, salt water, or any other fluid. The internal contents of the upper housing 212 include a fluid flow passageway which connects the inlet 245 and outlet 250, as well a head sealingly disposed in the passageway, as further described below.

[0047] The lower housing 211 comprises a portion of an elongate buckling rod 240. The lower housing 211 can be made up of an open housing support, such as two or more support rods 270 on opposing lateral sides or surrounding the outer peripheral circumference. Alternatively, or additionally, the lower housing 211 may include a closed housing (with or without suitably sized access windows) where the internal contents are enclosed by a walled structure. The buckling rod 240 extends from within the upper housing 212 from its proximal end through upper frame 276 to the base frame 275 at the buckling rod 240's distal end.

[0048] The support rods 270 extend from the upper frame 276 to the base frame 275. The support rods 270 provide mechanical strength for supporting the buckling rod 240 and maintaining the structure of the lower housing 211. For example, when fluid pressure is imposed at the inlet 245, the force of the pressure transfers through the buckling rod 240 against the base 275. Accordingly, with increased pressure at the inlet 245, the buckling rod 240 is forced axially against the base 275. With increased pressure the buckling rod is forced to carry a greater load and resulting force along its length. As discussed above, at some point the force or load imposed on the buckling rod 240 is so great that it begins to deform (bend, or bow) and then "buckles" or collapses, referred to herein as the buckling load. The occurrence is analogous to a column provided in a building between floors. The columns, like the buckling rod 240, are under concentric axial load. If the load imposed on the column by the upper floors becomes great enough, the column begins to deform, eventually buckling and collapsing.

[0049] The buckling load of a buckling rod 240 can depend on a number of factors, including material, length and diameter of the rod. Generally, the buckling rod is made up of solid steel or other metal. Conceivably, other materials could be employed such as a hard plastic or composite if sufficient

strength is provided. Further, with increased diameter the buckling load of the buckling rod 240 is increased. With the type of materials and diameter held constant, the buckling load of the buckling rod 240 is related to its length.

[0050] Accordingly, because the buckling load of the buckling rod 240 is proportional to its length, the buckling load can be increased by shortening the length of the buckling rod. The length of the buckling rod can be effectively, or artificially, shortened by applying lateral supports above the distal end of the buckling rod. For example, rather than the length of the buckling rod extending to base frame 275, the length would be essentially shorted to the point at which the lateral supports laterally engage and buttress the buckling rod. This can be seen with reference to FIG. 3, wherein lateral support projections 260 are extended within the housing to engage and buttress the buckling rod 240. These can be extended by screwing the lateral support projections 260 through aperture 262 which may be threaded. The lateral support projections 260 can be inserted into the aperture 262 through projection head 280 in the lower housing 211, and in particular support rod 270. As illustrated in FIG. 3, the lateral support projections 260 extend at about midway between the base frame 275 and the upper frame 276. Accordingly, the length of the buckling rod 240 is effectively cut in half by the extension of the lateral support projections 260. The length of the buckling rod 240 is then effectively measured from the point at which the lateral support projections buttress the buckling rod rather than the base support frame 275. The buckling load of the buckling rod 240 is proportional to its length, and therefore, by effectively shortening the length of the buckling rod 240, the strength of the rod, namely the buckling load, is raised.

[0051] While not held to any particular principle, the excess pressure, or axial force, that the buckling rod can accommodate may be determined by the Euler equation, namely formula (1) below:

$$F = \frac{\pi^2 EI}{(KL)^2} \quad (1)$$

Wherein F is the maximum or critical force (buckling load), E is modulus of elasticity, I is area or moment of inertia, L is unsupported length of column, and K is column effective length factor. Therefore, the buckling load is inversely proportional to the square of the length of the buckling rod. Accordingly, if the length of the buckling rod 240 is reduced by half, the force required to buckle the buckling rod 240 is increased by a factor of four.

[0052] As a result of the above relation, the buckling load can be tuned to a predetermined value. In particular, with materials known, as well as the related metallurgical properties, as well as length of the buckling rod, the buckling load can be determined. By adjusting the length, the buckling load can be varied to the desired predetermined force (or pressure imposed at the inlet). Accordingly, the lateral projections 260 can be extended at the desired points along the length of the elongate buckling rod 240 to give it a new effective length. Because the length will always be shortened by this process, the buckling load of the buckling rod 240 is increased and adjusted to a predetermined desired value. Therefore, an operator could choose a long buckling rod 240 and then apply the lateral projections 260 as desired to achieve a stronger predetermined buckling load. Generally, this buckling load can be just under the failure point of the materials in the work string.

[0053] The two lateral projections 260 are shown on opposite lateral sides on FIG. 3, thus forming one set of lateral projections. By having the projections 260 extend from opposite sides (about 180 degrees) from one

another, support can be provided in opposing directions to support the buckling rod 240. However, any number of rods, for example 2-20, can be provided thereby surrounding the buckling rod 240 to support and buttress the buckling rod 240. The lateral projections 260 can be positioned equidistantly around the buckling rod 240. For example, with two lateral projections, these can be placed at 180 degrees to one another as illustrated in FIG. 3A, three two lateral projections 260 can be paced at 120 degrees as illustrated in FIG. 3B, four two lateral projections can be placed at 90 degrees as shown in FIGS. 3C and 3D, and so on. The four lateral projections can be shaped to have a flat surface as in FIG. 3C or concave as in 3D. The concave shape allows the ends of the lateral projections 260 to engage a greater surface of the support buckling rod 240 for support. Accordingly, when a sufficient number of lateral projections 260 and/or shaped to engage the rod, the lateral projections 260 can effectively surround the buckling rod 240 when moved from a retracted configuration to an extended configuration, thus providing support to the buckling rod, effectively shortening its length.

[0054] Moreover, the lateral projections 260 should be made up of material which provides sufficient mechanical strength to support the buckling rod 240. For example, the lateral projections 260 can be made up of a metal such as steel, aluminum, iron, or a rigid plastic, or a composition material which includes a metal or plastic.

[0055] Although only one set of lateral projections 260 is shown in FIG. 3, a plurality of projections can be provided along the length of the housing 211. For example, there could be 2-20 sets provided to extend to buttress the buckling rod 240. Each set can effectively shorten the length of the buckling rod 240 and thereby increase its strength and buckling load. The force required to buckle the buckling rod at each point of engagement by the lateral projections 260 can be calculated beforehand, and located to

the desired point along the housing 211 to obtain the desired buckling load. In this way, an operator can be enabled to select from a variety of buckling loads and engage the desired lateral projection 260 to obtain the desired buckling load.

[0056] Additionally or alternatively, instead of threaded aperture in 262, the aperture could be an elongate slot, and the lateral projections 260 coupled by projection head 280 to be slidable within such slot. Accordingly, the lateral projection could be moved longitudinally back and forth within such slot to the desired location to obtain the desired buckling load. The lateral projections 260 could then be extended to buttress the buckling rod 260.

[0057] Referring now to FIG. 4, an adjustable relief valve 200 coupled to a surface work string 55 having fracturing fluid 108. The fracturing fluid 108 is pumped by pumping system 50 to a rig or wellhead 125 and into the casing 110. The adjustable relief valve 200 is shown having inlet 245 and relief outlet 250. As shown the adjustable relieve valve has a sealing mechanism 220 within its housing 210. The sealing mechanism 220 has a head 230 and buckling rod 240. The head 230 is sealingly disposed within the passageway between the inlet 245 and the relief outlet 250 thus closing the passageway to fluid flow. The head 230 can for example include a number of seals 231 and 232 which prevents the flow of fluid to the relief outlet 250 and into the interior space 213 of the upper housing 212. Further shown by the arrows, fracturing fluid 108 is under pressure and imposes force against the head 230 due to seals 232 being of larger area exposed to fluid flow 108 than the exposed area of seal 231, thus placing axial force on the buckling rod 240. The lateral projections 260 can be extended to buttress the buckling rod 240. In the illustrated embodiment, the lateral projections 260 are in a retracted configuration, retracted away from the

buckling rod 240. The lateral projections 260 can be actuated, or screwed to engage and buttress the buckling rod 240.

[0058] In addition to screwing the lateral projections 260, a lever mechanism can be employed for manually extending or retracting the lateral projections 260. Alternatively, or additionally, these lateral projections 260 can be extended and retracted via hydraulic, electric, pneumatic or other mechanism and may be provided as part of projection head 280. For example a solenoid plunger may be employed, or an electromechanical device where an electromagnetic field is produced to extend or withdraw a projection. The system or operation for extending and retracting the lateral projections 260 is not particularly restricted.

[0059] The action of the buckling rod 240 and lateral projections are illustrated in FIGS. 5-8. FIG. 5 shows a buckling rod 240 having variable length  $x$ . Based on this length the buckling rod 240 has a particular buckling load. Illustrated in FIG. 6, the lateral projections 240 are extended from the housing to engage and buttress the buckling rod 240 midway between the ends of the buckling rod 240. The new length of the buckling rod is therefore effectively shortened and made equal to  $y$  (the distance from the head 230 to the point of engagement by the lateral projections 260). As the length  $y$  is less than the length  $x$ , the strength of the buckling rod 240, and in particular the buckling load, is increased according to the formula  $I$  (inverse square). As shown in FIG. 7, the lateral projections 260 can be then be retracted from the buckling rod 240, thus returning the buckling rod 260 to its original length, where  $y$  is the length above the lateral projections 260, and  $Z$  is the length below the lateral projections 260, wherein  $y + z = x$ .

[0060] As shown in FIG. 8, the buckling rod 240 is buckled, or collapsed, due to pressure imposed on head 230. In particular, the pressure from fluid in the inlet was great enough that the axial force on the buckling

rod 240 exceeded the buckling load, causing buckling of the buckling rod 240. As a result of the collapse, the head 230 no longer has support from the buckling rod 240 and slides to below relief outlet 250 thus opening the path between the inlet 245 and relief outlet 250. Accordingly, due to the pressure of the system that the inlet 245 is coupled to, fluid is forced out the relief outlet 250 thereby releasing pressure.

[0061] Additionally, the lateral projections 260 can be configured to retract when the work string to which it is coupled reaches a particular predetermined pressure. For example, referring to FIG. 4, a pressure detector 57, such as a transducer, can be coupled to the surface work string, such as surface work string 55. The lateral projections 260 can initially be set in the extended configuration to buttress the buckling rod 240 as in FIG. 6. Further, the pressure detector can be communicatively coupled to the projection head 280 and lateral projections 260. The projection head 280 can have a set release 285 (FIG. 8) which automatically retracts the lateral projections 260 upon detection of an overpressure condition in the work string system, and can be a hydraulic or an electronic mechanism, such as a solenoid plunger. For example, when the pressure detector detects a particular predetermined pressure, such as a pressure indicative of an overpressure condition, the lateral projections 260 can then be retracted from the buckling rod 240. Accordingly, as the length of the buckling rod is then effectively lengthened, the buckling load decreases. As such, the buckling rod 240 can then buckle as shown in FIG. 8 relieving pressure in the system. A system controller 800 can also be employed and communicatively coupled with the detector 57 and the projection head 280 and/or set release 285. Accordingly, an operator could extend or retract the lateral projections 260 as desired via the system controller 800. Further, the controller could be configured such that an operator could set a predetermined pressure in the system for retraction of the lateral projections

260 occur. Upon reaction this pressure, the lateral projections 260 may then be automatically retracted and the system pressure relieved. Additionally, a plurality of adjustable pressure relief valves 200 could be employed at various points in the system and communicatively coupled to the system controller 800. Accordingly retraction and release of the lateral projections 260 of each of the plurality of pressure relief valves 200 could be conducted by an operator operating the system controller 800, or the system controller 800 configured to retract the lateral projections 260 of the plurality of the plurality of pressure relief valves 200 at a particular pressure. Accordingly, when a particular pressure is detected by the detector 57, the system controller 800 could transmit a signal to each of the pressure relief valves for retraction of the lateral projections 260 and release of each of the pressure relief valves 200.

[0062] Additionally, the entire system could be tested using a "test pressure." The test pressure would be higher than a "working pressure", where the working pressure is the typical pressure of the system during an ordinary operation such as fracturing. The test pressure can also be higher than the predetermined pressure for retraction of the lateral projections 260. This assures the system will hold pressure up to the test pressure or until the set release 285 is activated.

[0063] With reference to FIG. 9, an exemplary system and/or system controller 800 includes a processing unit (for example, a central processing unit (CPU) or processor) 820 and a system bus 810 that couples various system components, including the system memory 830 such as read only memory (ROM) 840 and random access memory (RAM) 850, to the processor 820. The system controller 800 can include a cache 822 of high-speed memory connected directly with, in close proximity to, or integrated as part of the processor 820. The system controller 800 can copy data from the memory 830 and/or the storage device 860 to the cache 822 for access

by the processor 820. These and other modules can control or be configured to control the processor 820 to perform various operations or actions. The memory 830 can include multiple different types of memory with different performance characteristics.

[0064] Multiple processors or processor cores can share resources such as memory 830 or the cache 822, or can operate using independent resources. The processor 820 can include one or more of a state machine, an application specific integrated circuit (ASIC), or a programmable gate array (PGA) including a field PGA. The system bus 810 can be any of several types of bus structures including a memory bus or memory controller, a peripheral bus, and a local bus using any of a variety of bus architectures. A basic input/output (BIOS) stored in ROM 840 or the like, may provide the basic routine that helps to transfer information between elements within the system controller 800, such as during start-up.

[0065] The system controller 800 can further include storage devices 260 or computer-readable storage media such as a hard disk drive, a magnetic disk drive, an optical disk drive, tape drive, solid-state drive, RAM drive, removable storage devices, a redundant array of inexpensive disks (RAID), hybrid storage device, or the like. The storage device 860 can include software modules 862, 864, 866 for controlling the processor 820. The system controller 800 can include other hardware or software modules. Although the exemplary embodiment(s) described herein employs a hard disk as the storage device 860, other types of computer-readable storage devices which can store data that are accessible by a computer, such as magnetic cassettes, flash memory cards, digital versatile disks (DVDs), cartridges, random access memories (RAMs) 850, read only memory (ROM) 840, a cable containing a bit stream and the like may also be used in the exemplary operating environment. Tangible computer-readable storage media, computer-readable storage devices, or computer-readable memory

devices, expressly exclude media such as transitory waves, energy, carrier signals, electromagnetic waves, and signals per se.

[0066] The basic components and appropriate variations can be modified depending on the type of device, such as whether the system controller 800 is a small, handheld computing device, a desktop computer, or a computer server. When the processor 820 executes instructions to perform "operations", the processor 820 can perform the operations directly and/or facilitate, direct, or cooperate with another device or component to perform the operations.

[0067] To enable user interaction with the system controller 800, an input device 890 represents any number of input mechanisms, such as a microphone for speech, a touch-sensitive screen for gesture or graphical input, keyboard, mouse, motion input, speech and so forth. An output device 870 can also be one or more of a number of output mechanisms known to those of skill in the art. In some instances, multimodal systems enable a user to provide multiple types of input to communicate with the system controller 800. The communications interface 880 generally governs and manages the user input and system output. There is no restriction on operating on any particular hardware arrangement and therefore the basic hardware depicted may easily be substituted for improved hardware or firmware arrangements as they are developed.

[0068] One or more parts of the example system controller 800, up to and including the entire system controller 800, can be virtualized. For example, a virtual processor can be a software object that executes according to a particular instruction set, even when a physical processor of the same type as the virtual processor is unavailable.

[0069] Numerous examples are provided herein to enhance understanding of the present disclosure. A specific set of examples are

provided as follows. In a first example, an adjustable release pressure relief valve is disclosed, including a housing having an inlet and a relief outlet connected by a fluid flow passageway, the inlet fluidly connectible to a work string; a head sealingly disposed within the passageway between the inlet and relief outlet closing the fluid flow passageway between the inlet and relief outlet; an elongate buckling rod supporting the head and bucklable at a predetermined load thereby permitting sliding of the head from between the inlet and a relief outlet and opening the fluid flow passageway; and a lateral support projection extendable within the housing to buttress the buckling rod along a longitudinal length of the buckling rod thereby increasing the load at which the buckling rod is collapsible.

[0070] In a second example, a pressure relief valve according to the first example is disclosed, further including a plurality of lateral support projections extendable within the housing to buttress the buckling rod at different points along the longitudinal length of the buckling rod.

[0071] In a third example, a pressure relief valve according to first or second examples is disclosed, further including at least two lateral support projections extendable from opposite lateral sides with respect to the elongate buckling rod.

[0072] In a fourth example, a pressure relief valve is disclosed according to any of the preceding examples first to the third, wherein the lateral support projection is slidably settable along the length of the housing to extend at different points along the length of the buckling rod.

[0073] In a fifth example, a pressure relief valve is disclosed according to any of the preceding examples first to the fourth, further including a set release communicatively coupled to the lateral support projection for extending the lateral support projection to buttress the elongate buckling rod.

[0074] In a sixth example, a pressure relief valve is disclosed according to any of the preceding examples first to the fifth, wherein the lateral support projection extends through the housing.

[0075] In a seventh example, a pressure relief valve is disclosed according to any of the preceding examples first to the sixth, further including a set release communicatively coupled to the lateral support projection for retracting an extended lateral support projection.

[0076] In an eighth example, a pressure relief valve is disclosed according to any of the preceding examples first to the seventh, further including a pressure detector communicatively coupled to the set release, wherein the set release retracts the extended lateral support projection upon detection of a predetermined pressure by the pressure detector.

[0077] In a ninth example, a pressure relief valve disclosed according to any of the preceding examples first to the eighth, wherein the pressure detector is coupled to the work string and detects a pressure within the work string.

[0078] In a tenth example, a work string is disclosed, including a tubular conveyance having a pump and a variable strength pressure relief valve; the variable strength pressure relief valve having a housing having an inlet and a relief outlet connected by a fluid flow passageway, the inlet fluidly connected to the tubular conveyance; a head sealingly disposed within the passageway between the inlet and relief outlet closing the fluid flow passageway between the inlet and relief outlet; an elongate buckling rod supporting the head and bucklable at a predetermined load thereby permitting sliding of the head from between the inlet and a relief outlet and opening the fluid flow passageway; and a lateral support projection extendable within the housing to buttress the buckling rod along a

longitudinal length of the buckling rod thereby increasing the load at which the buckling rod is collapsible.

[0079] In an eleventh example, a work string according to the tenth example is disclosed, wherein the tubular conveyance includes a fluid.

[0080] In a twelfth example, a work string is disclosed according to the tenth or eleventh examples, wherein the tubular conveyance includes a fracturing fluid.

[0081] In a thirteenth example, a work string is disclosed according to any of the preceding examples tenth to the twelfth, wherein the pressure relief valve includes a plurality of lateral support projections extendable within the housing to buttress the buckling rod at different points along the longitudinal length of the buckling rod.

[0082] In a fourteenth example, a work string is disclosed according to any of the preceding examples tenth to the thirteenth, wherein the pressure relief valve further includes at least two lateral support projections extendable from opposite lateral sides with respect to the elongate buckling rod.

[0083] In a fifteenth example, a work string is disclosed according to any of the preceding examples tenth to the fourteenth, wherein the lateral support projection is slidably settable along the length of the housing to extend at different points along the length of the buckling rod.

[0084] In a sixteenth example, a work string is disclosed according to any of the preceding examples tenth to the fifteenth, further including a set release communicatively coupled to the lateral support projection for extending the lateral support projection to buttress the elongate buckling rod.

[0085] In a seventeenth example, a work string is disclosed according to any of the preceding examples tenth to the sixteenth, wherein the lateral support projection extends through the housing.

[0086] In an eighteenth example, a work string is disclosed according to any of the preceding examples tenth to the seventeenth, further including a set release communicatively coupled to the lateral support projection for retracting an extended lateral support projection.

[0087] In a nineteenth example, a work string is disclosed according to any of the preceding examples tenth to the eighteenth, further including a pressure detector coupled to the work string for detecting a pressure of a fluid within the work string.

[0088] In a twentieth example, a work string is disclosed according to any of the preceding examples tenth to the nineteenth, wherein the pressure detector is communicatively coupled to the set release, wherein the set release retracts the extended lateral support projection upon detection of a predetermined pressure by the pressure detector.

[0089] The embodiments shown and described above are only examples. Therefore, many such details are neither shown nor described. Even though numerous characteristics and advantages of the present technology have been set forth in the foregoing description, together with details of the structure and function of the present disclosure, the disclosure is illustrative only, and changes may be made in the detail, especially in matters of shape, size and arrangement of the parts within the principles of the present disclosure to the full extent indicated by the broad general meaning of the terms used in the attached claims. It will therefore be appreciated that the embodiments described above may be modified within the scope of the appended claims.

## CLAIMS

What is claimed is:

1. An adjustable release pressure relief valve comprising:
  - a housing having an inlet and a relief outlet connected by a fluid flow passageway, the inlet fluidly connectible to a work string;
  - a head sealingly disposed within the passageway between the inlet and relief outlet closing the fluid flow passageway between the inlet and relief outlet;
  - an elongate buckling rod supporting the head and bucklable at a predetermined load thereby permitting sliding of the head from between the inlet and a relief outlet and opening the fluid flow passageway; and
  - a lateral support projection extendable within the housing to buttress the buckling rod along a longitudinal length of the buckling rod thereby increasing the load at which the buckling rod is collapsible.
2. The pressure relief valve of claim 1, further comprising a plurality of lateral support projections extendable within the housing to buttress the buckling rod at different points along the longitudinal length of the buckling rod.
3. The pressure relief valve of claim 1, further comprising at least two lateral support projections extendable from opposite lateral sides with respect to the elongate buckling rod.
4. The pressure relief valve of claim 1, wherein the lateral support projection is slidably settable along the length of the housing to extend at different points along the length of the buckling rod.
5. The pressure relief valve of claim 1, further comprising a set release communicatively coupled to the lateral support projection for extending the lateral support projection to buttress the elongate buckling rod.

6. The pressure relief valve of claim 1, wherein the lateral support projection extends through the housing.
7. The pressure relief valve of claim 1, further comprising a set release communicatively coupled to the lateral support projection for retracting an extended lateral support projection.
8. The pressure relief valve of claim 7, further comprising a pressure detector communicatively coupled to the set release, wherein the set release retracts the extended lateral support projection upon detection of a predetermined pressure by the pressure detector.
9. The pressure relief valve of claim 8, wherein the pressure detector is coupled to the work string and detects a pressure within the work string.
10. A work string comprising:
  - a tubular conveyance having a pump and a variable strength pressure relief valve;
  - the variable strength pressure relief valve having a housing having an inlet and a relief outlet connected by a fluid flow passageway, the inlet fluidly connected to the tubular conveyance;
  - a head sealingly disposed within the passageway between the inlet and relief outlet closing the fluid flow passageway between the inlet and relief outlet;
  - an elongate buckling rod supporting the head and bucklable at a predetermined load thereby permitting sliding of the head from between the inlet and a relief outlet and opening the fluid flow passageway; and
  - a lateral support projection extendable within the housing to buttress the buckling rod along a longitudinal length of the buckling rod thereby increasing the load at which the buckling rod is collapsible.

11. The work string of claim 10, wherein the tubular conveyance comprises a fluid.

12. The work string of claim 10, wherein the tubular conveyance comprises a fracturing fluid.

13. The work string of claim 10, wherein the pressure relief valve comprises a plurality of lateral support projections extendable within the housing to buttress the buckling rod at different points along the longitudinal length of the buckling rod.

14. The work string of claim 10, wherein the pressure relief valve further comprises at least two lateral support projections extendable from opposite lateral sides with respect to the elongate buckling rod.

15. The work string of claim 10, wherein the lateral support projection is slidably settable along the length of the housing to extend at different points along the length of the buckling rod.

16. The work string of claim 10, further comprising a set release communicatively coupled to the lateral support projection for extending the lateral support projection to buttress the elongate buckling rod.

17. The work string of claim 10, wherein the lateral support projection extends through the housing.

18. The work string of claim 10, further comprising a set release communicatively coupled to the lateral support projection for retracting an extended lateral support projection.

19. The work string of claim 18, further comprising a pressure detector coupled to the work string for detecting a pressure of a fluid within the work string.

20. The work string of claim 19, wherein the pressure detector is communicatively coupled to the set release, wherein the set release retracts the extended lateral support projection upon detection of a predetermined pressure by the pressure detector.

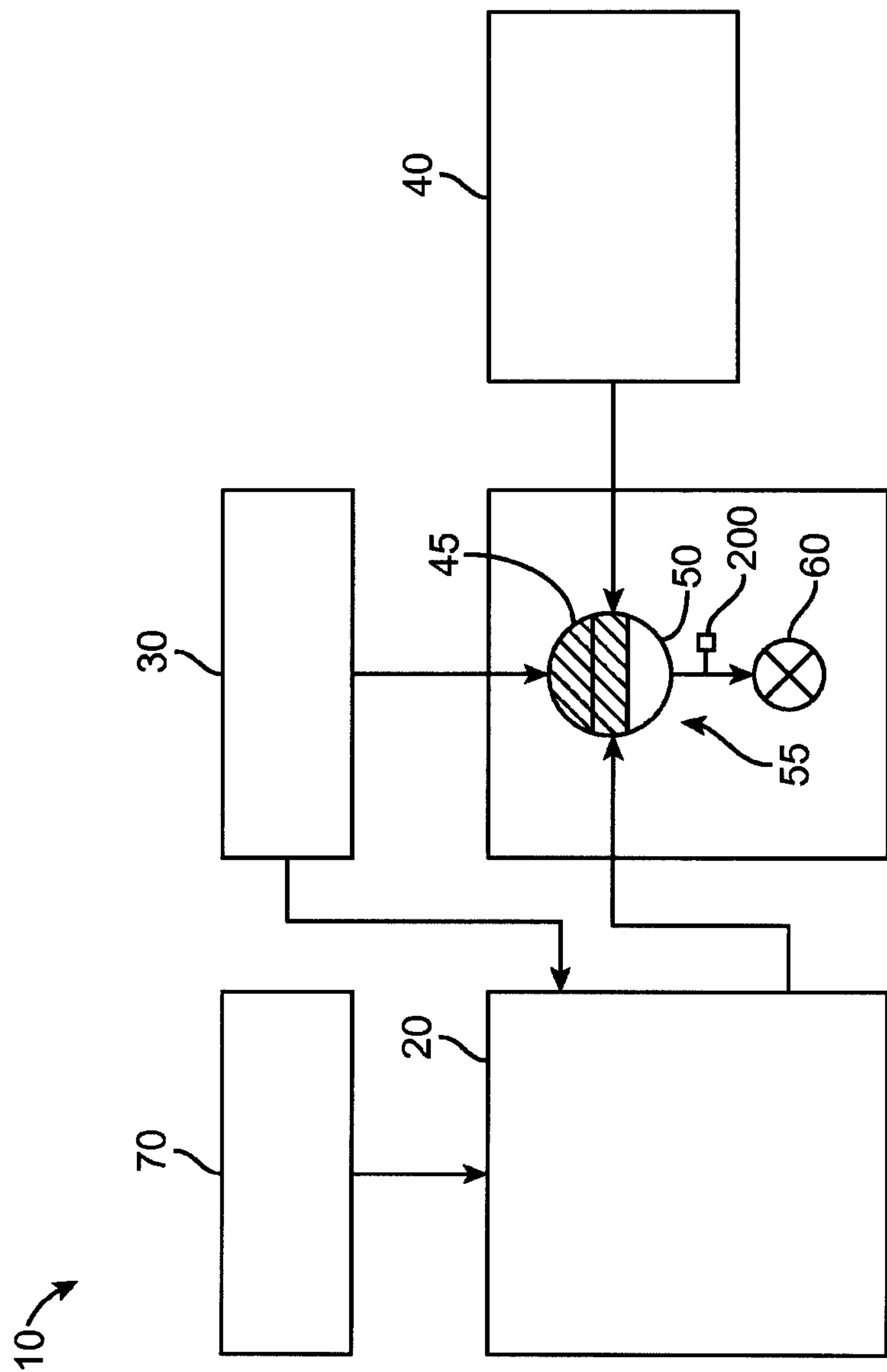

FIG. 1

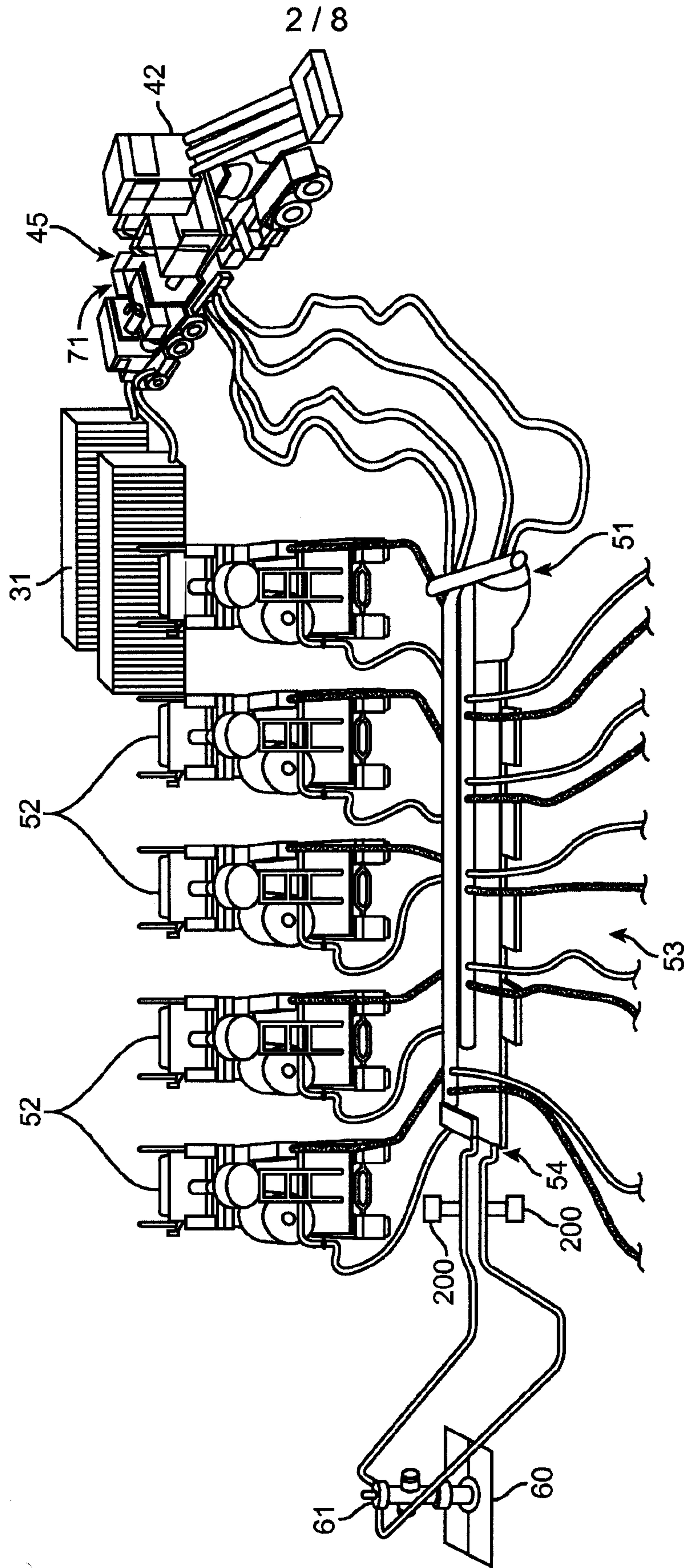

FIG. 1A

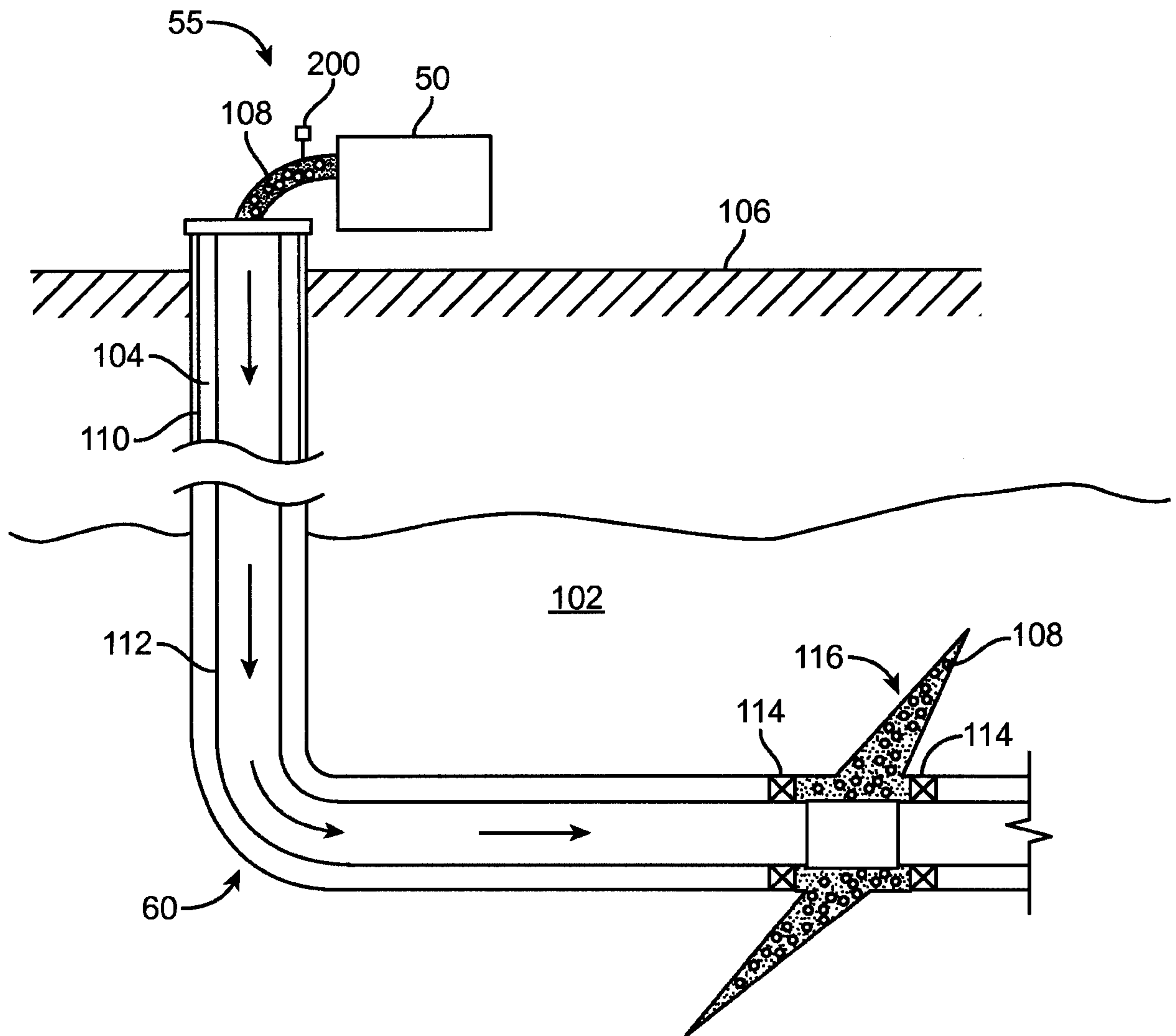

FIG. 2

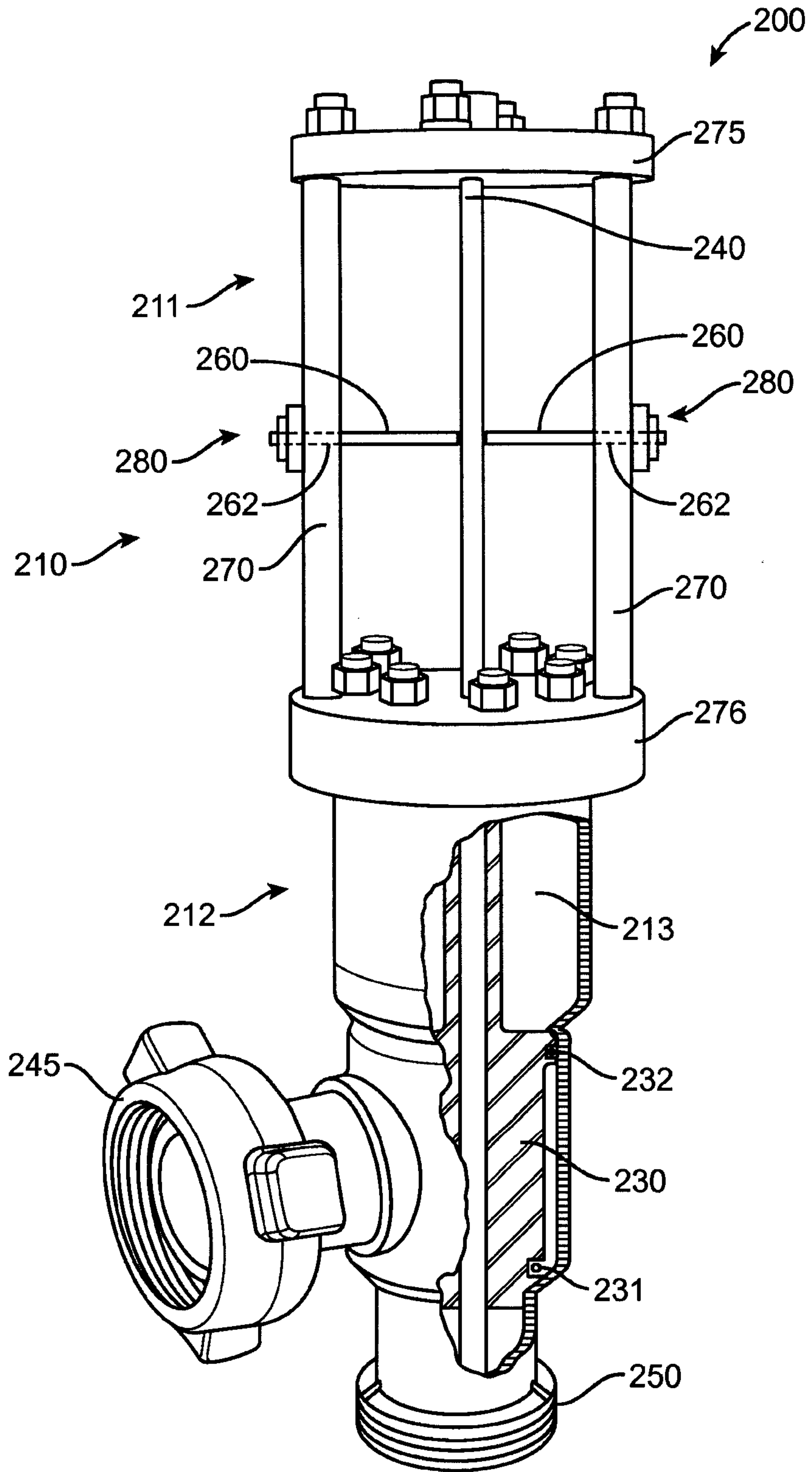

FIG. 3

5 / 8



FIG. 3A

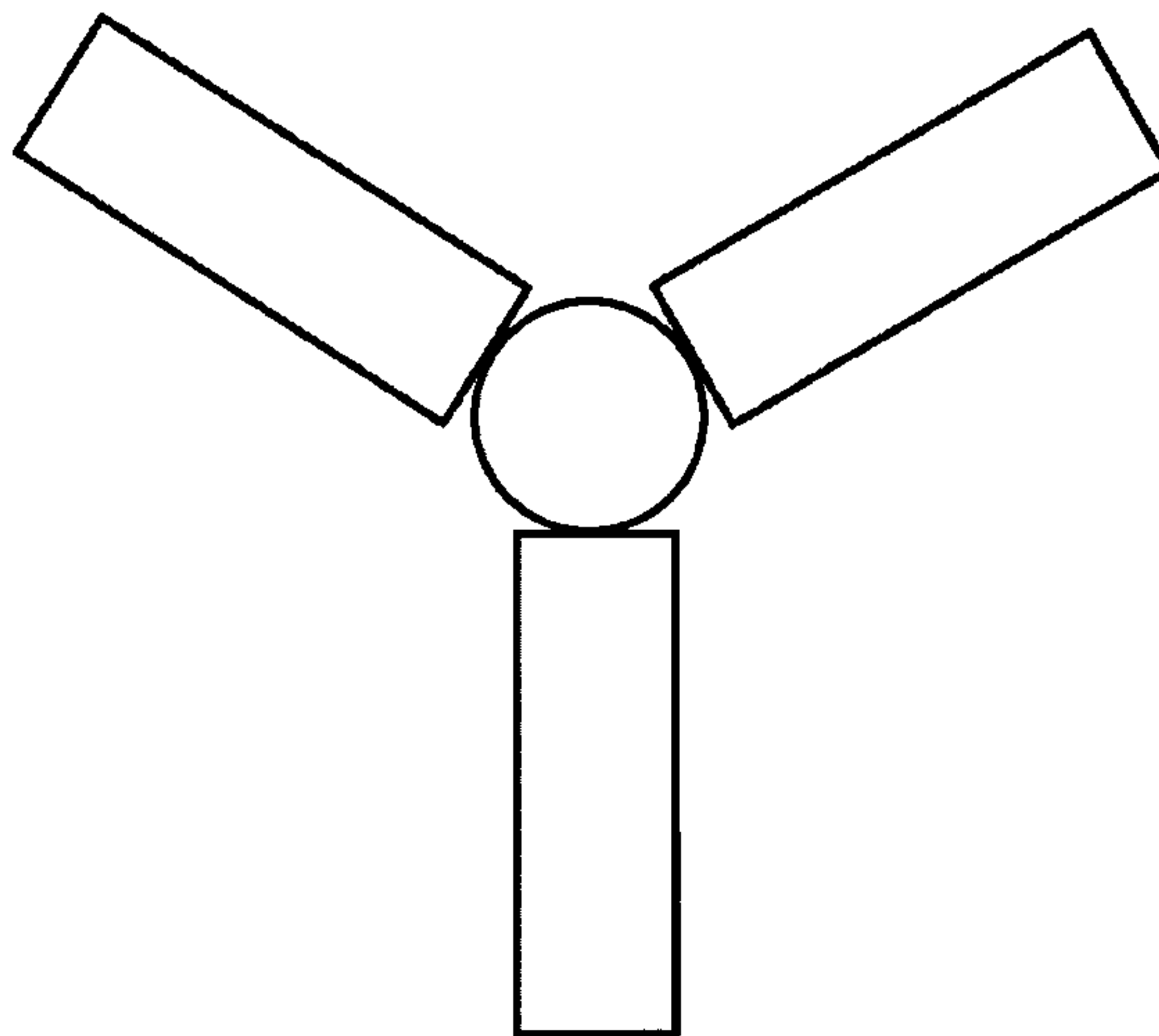

FIG. 3B

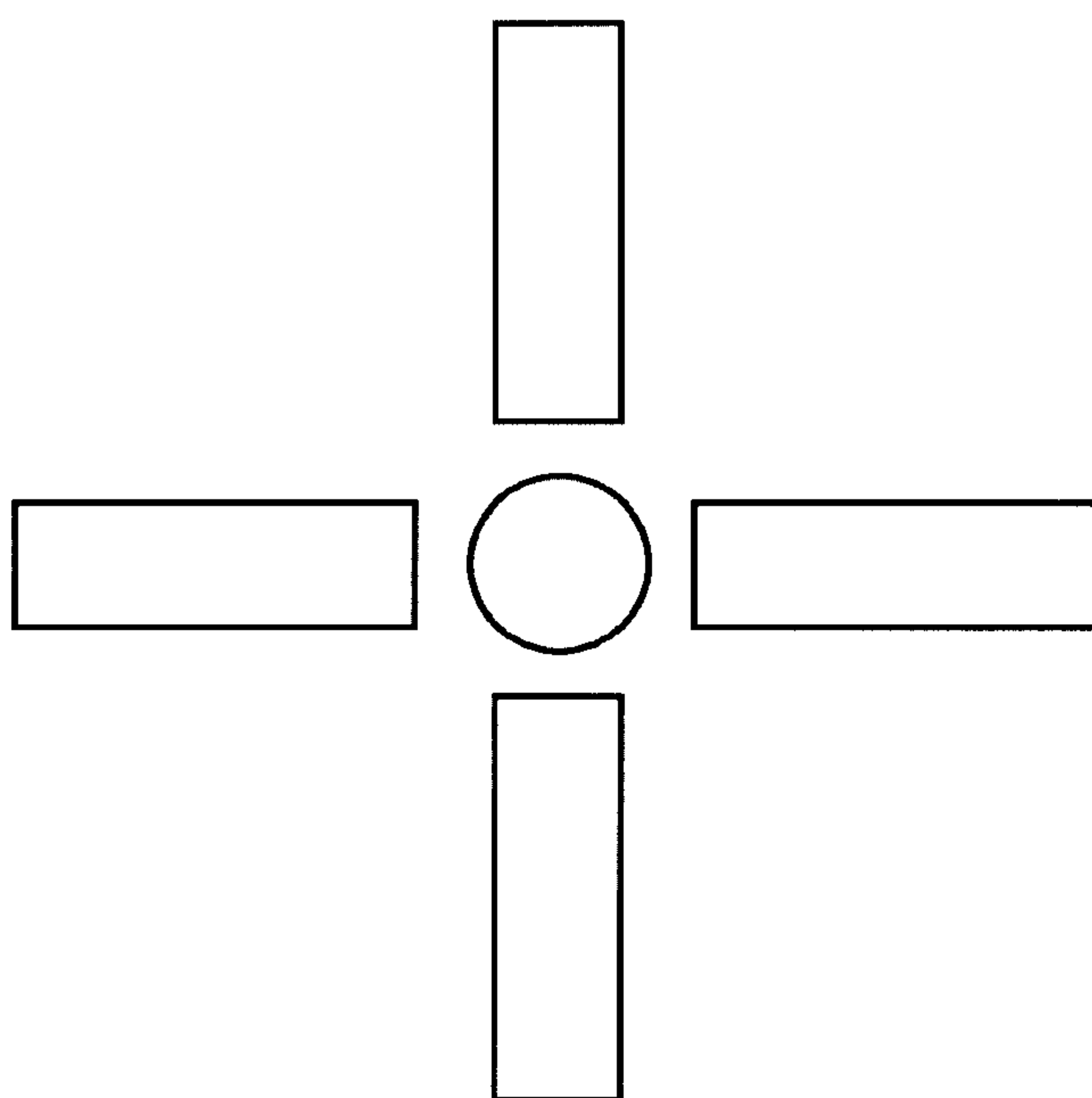

FIG. 3C

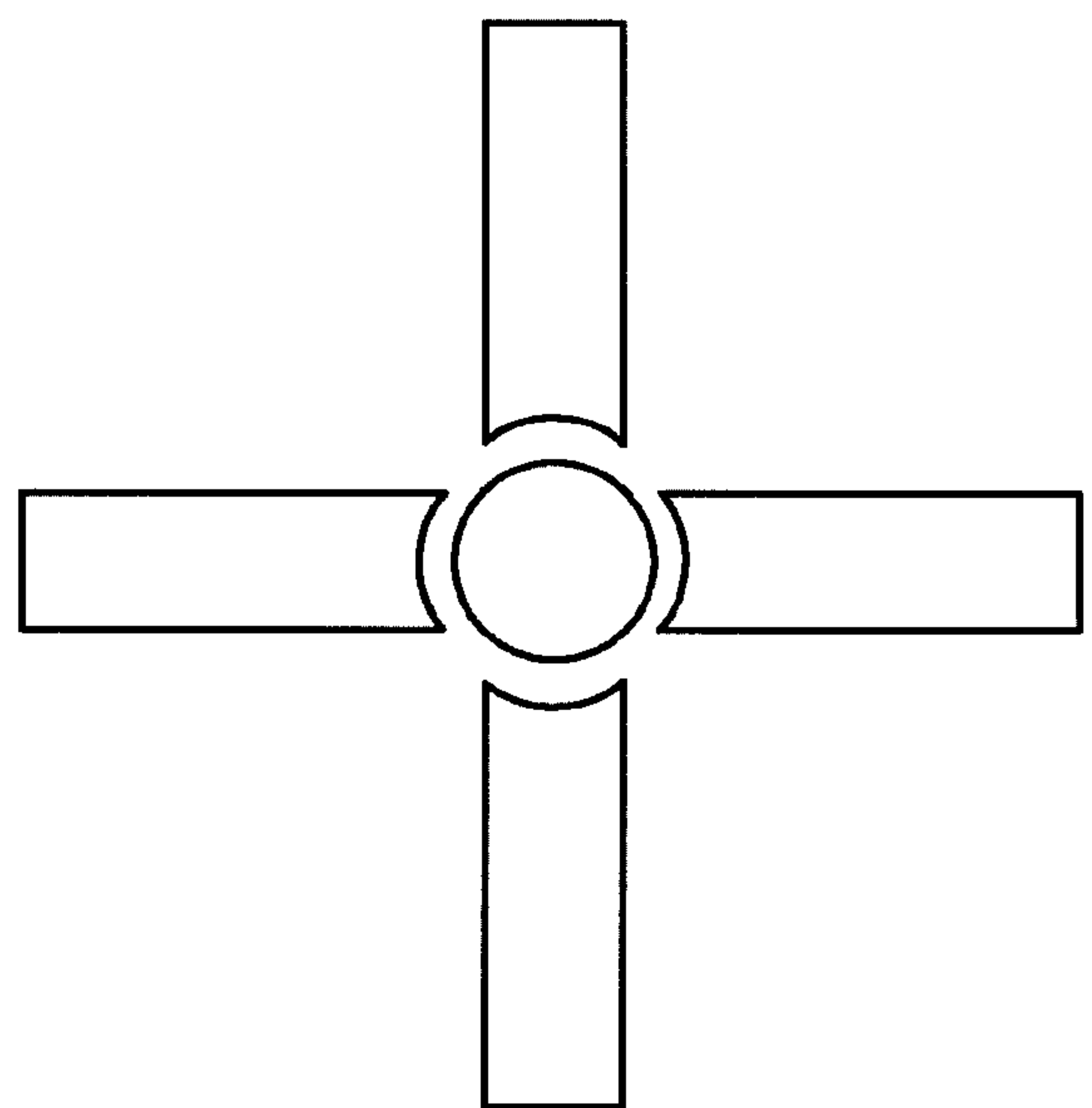

FIG. 3D



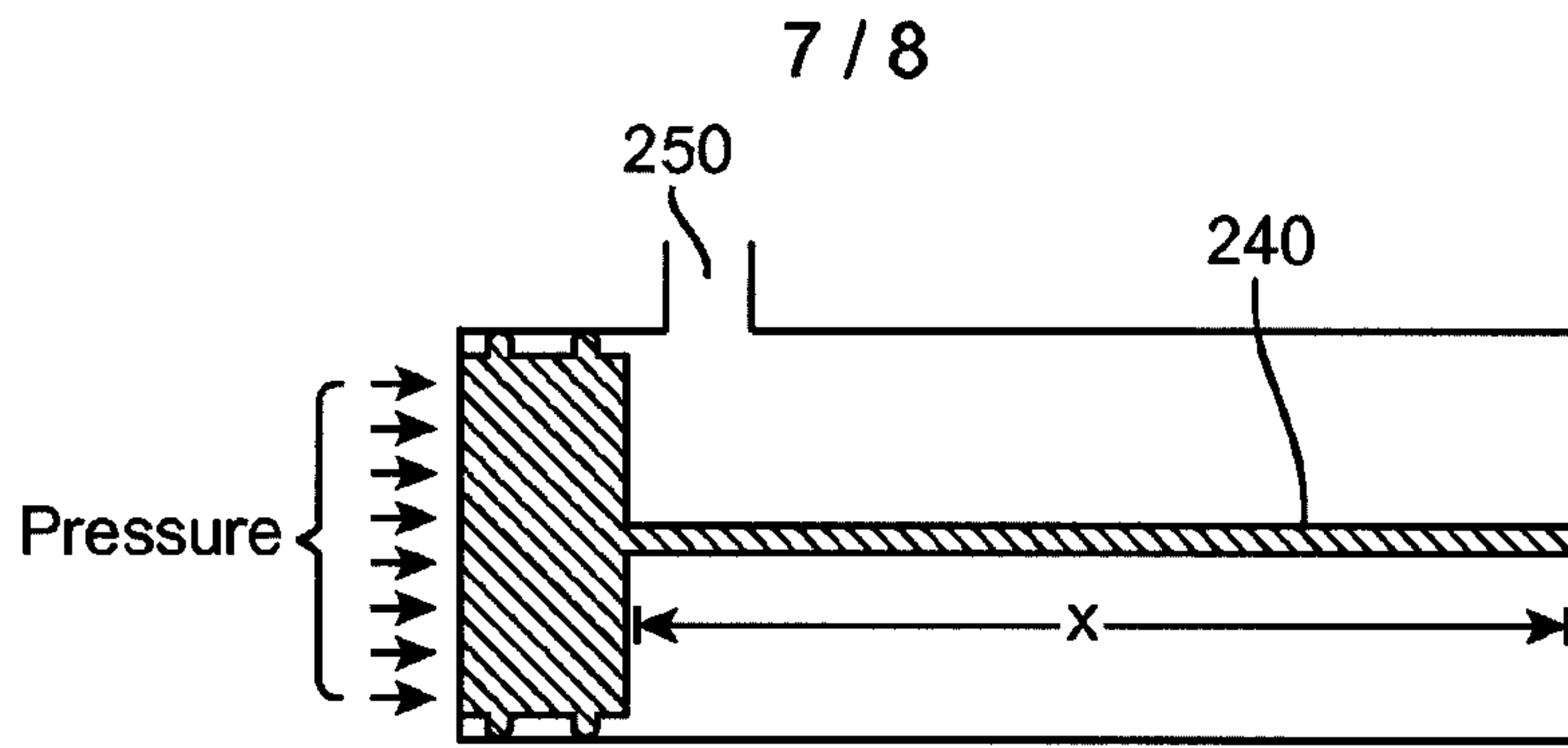

FIG. 5

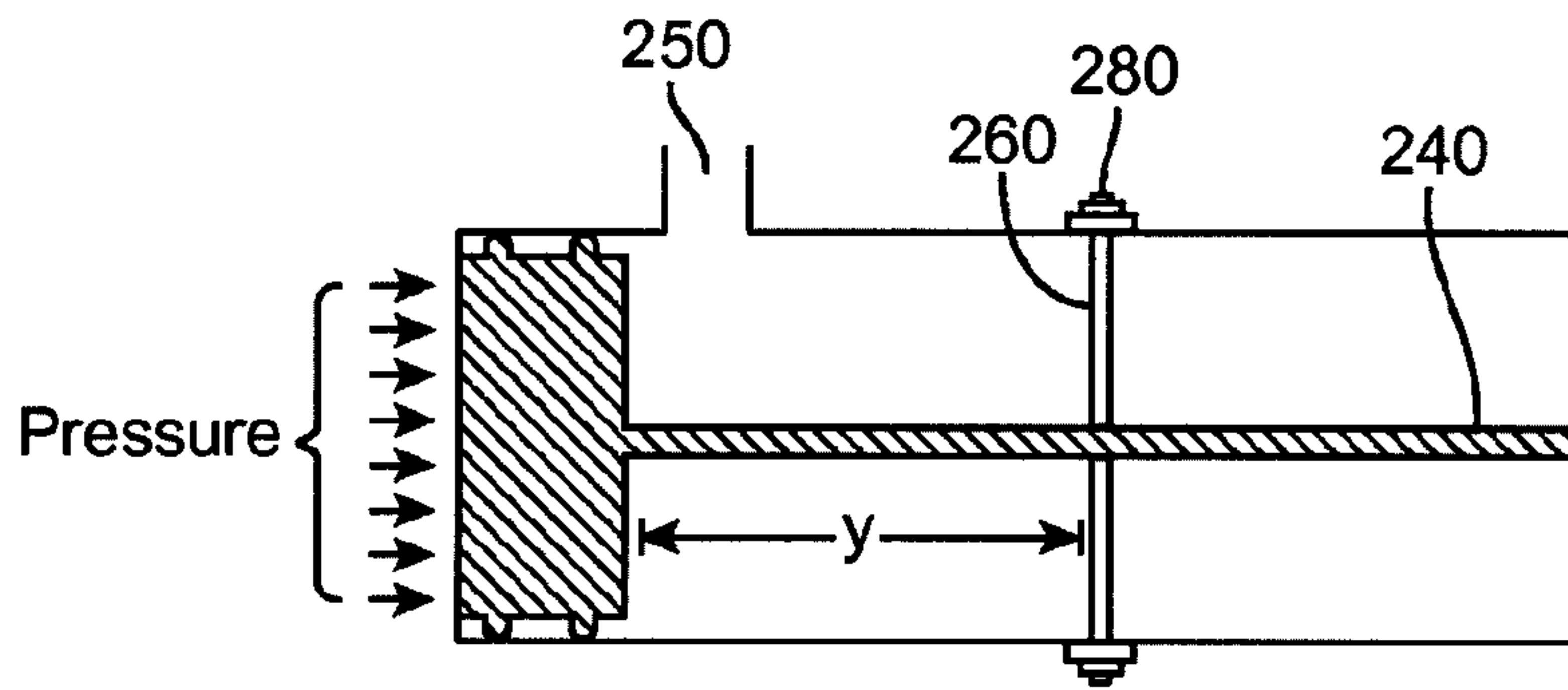

FIG. 6

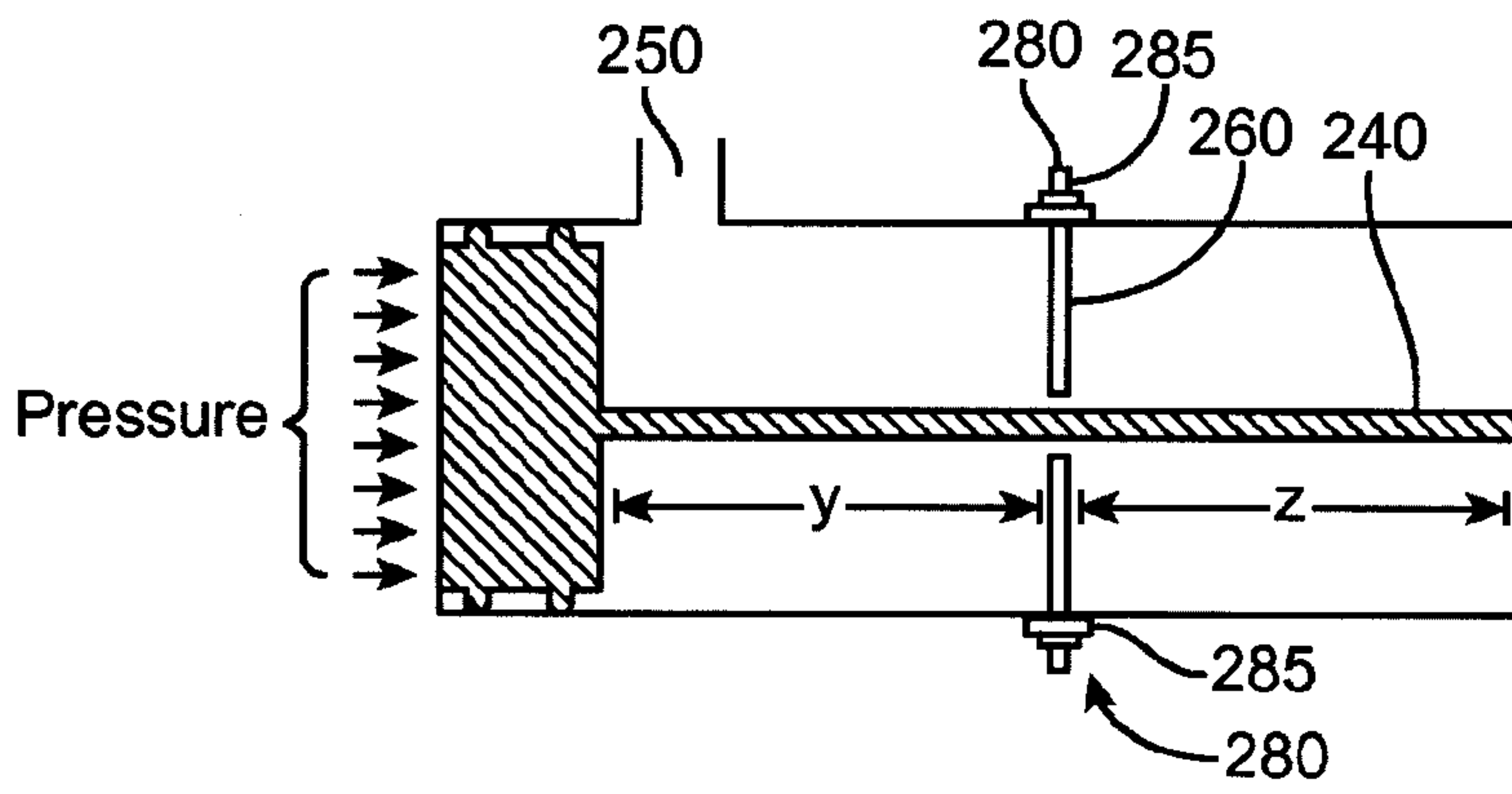

FIG. 7

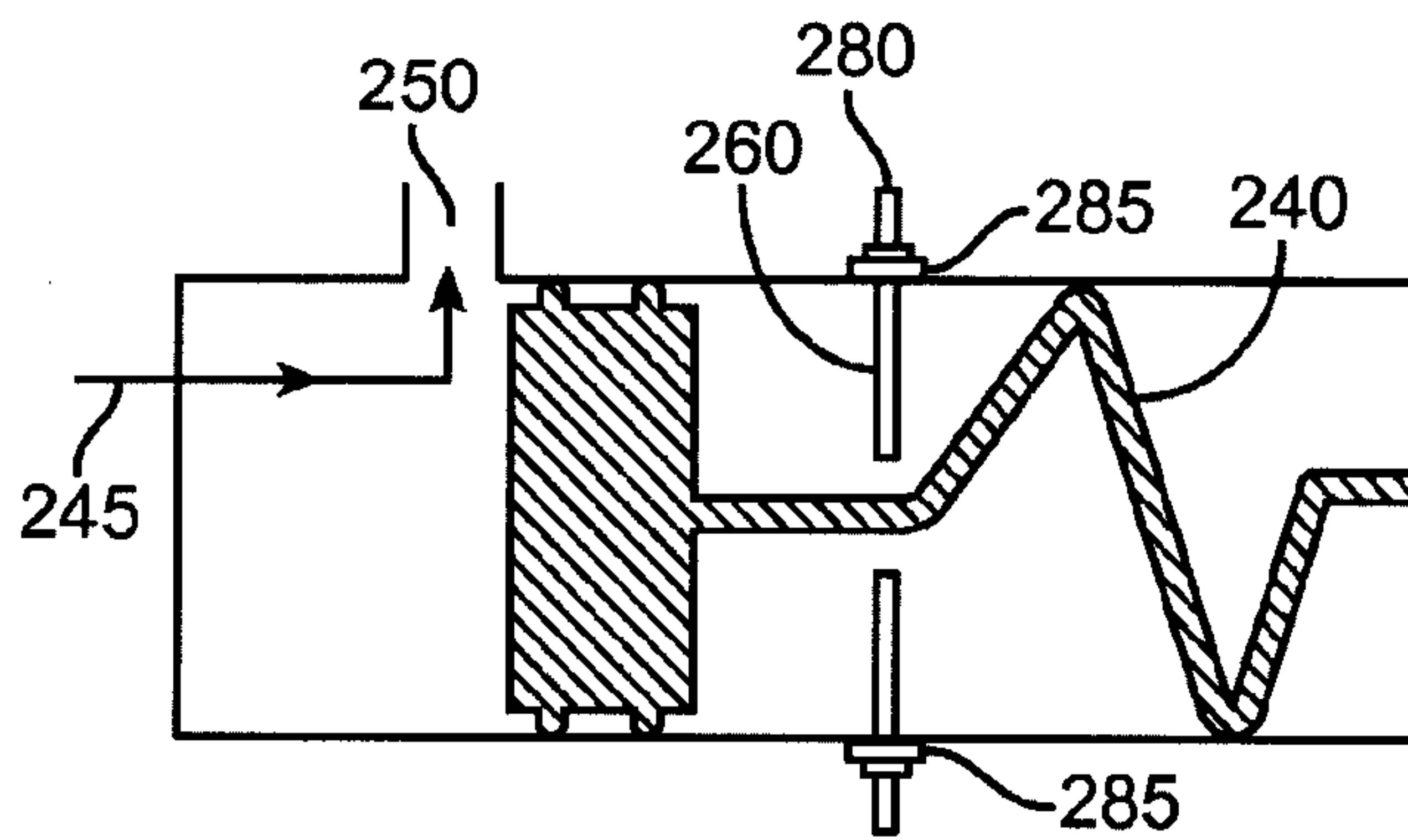

FIG. 8

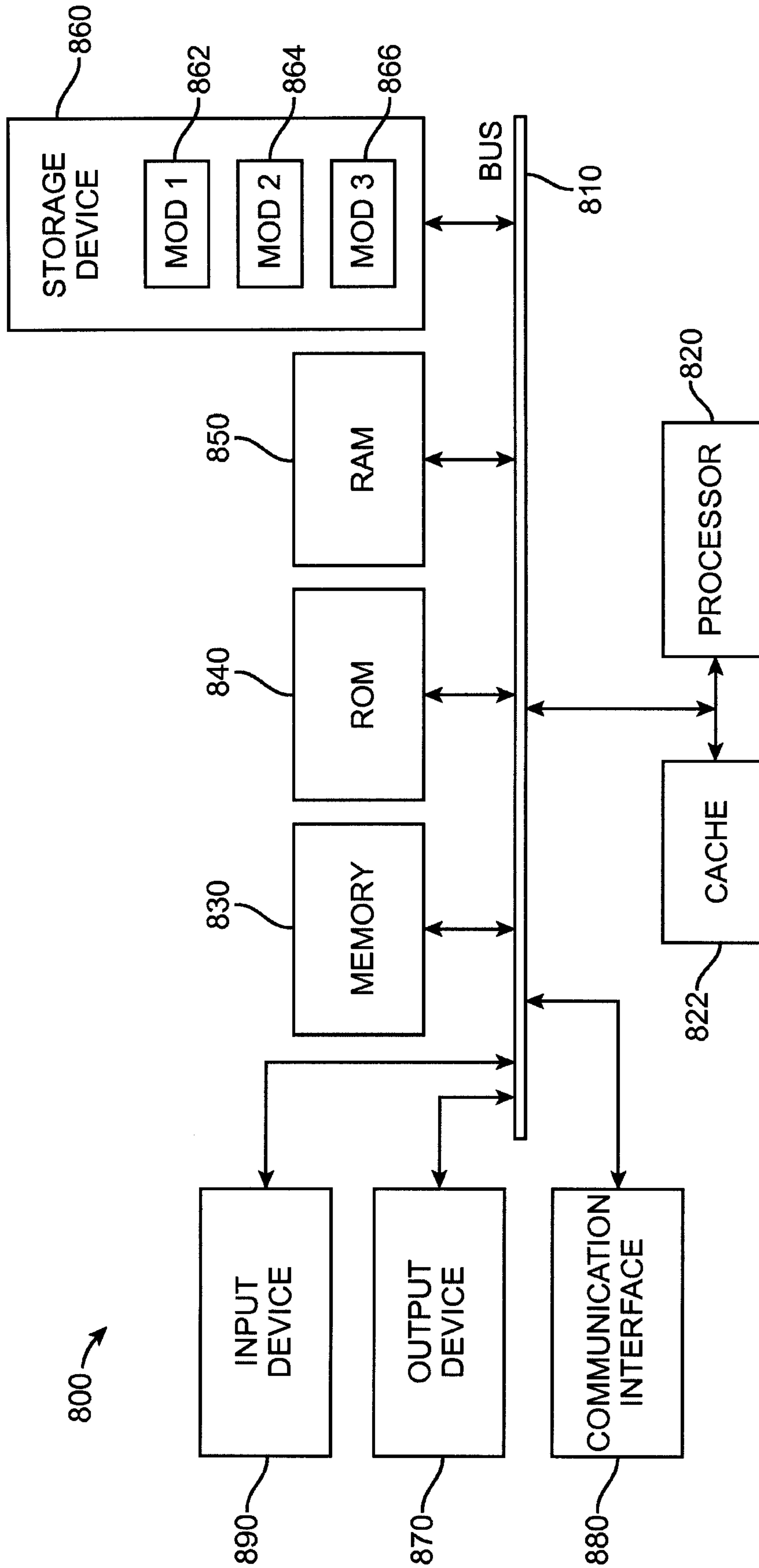

FIG. 9

