

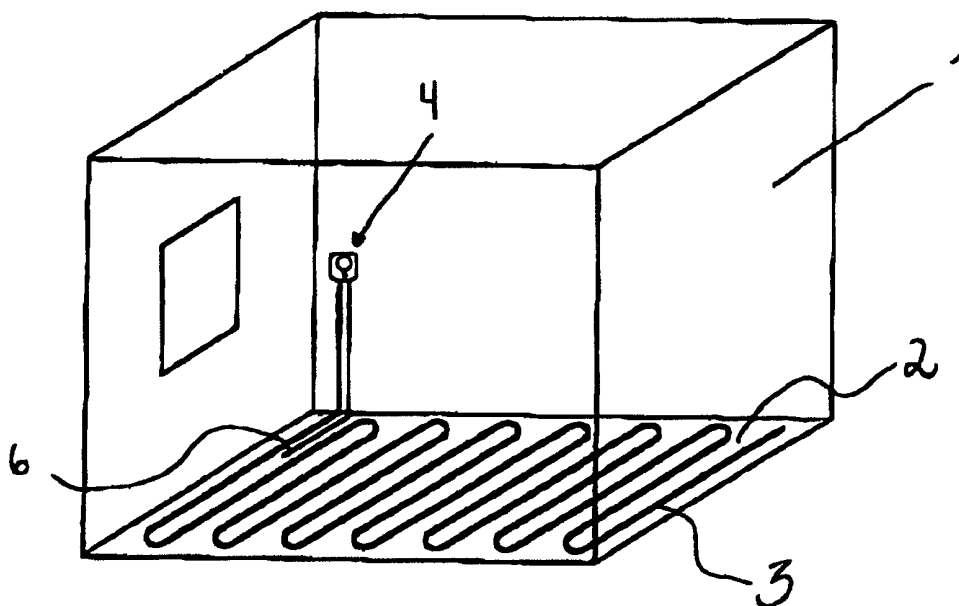

INTERNATIONAL APPLICATION PUBLISHED UNDER THE PATENT COOPERATION TREATY (PCT)

(51) International Patent Classification ⁷ : G05D 23/19	A1	(11) International Publication Number: WO 00/08537 (43) International Publication Date: 17 February 2000 (17.02.00)
<p>(21) International Application Number: PCT/DK99/00428</p> <p>(22) International Filing Date: 2 August 1999 (02.08.99)</p> <p>(30) Priority Data: PA 1998 01004 3 August 1998 (03.08.98) DK</p> <p>(71) Applicant (for all designated States except US): BRAMPTON HOLDINGS LIMITED [GB/GB]; Thomas Edge House, Tunnell Street, St. Helier, Jersey (GB).</p> <p>(72) Inventor; and (75) Inventor/Applicant (for US only): CHRISTENSEN, Tage [DK/ES]; Quet Zull II App 9L, Guadalmina, San Pedro, Malaga (ES).</p> <p>(74) Agent: HOFMAN-BANG & BOUTARD, LEHMANN & REE A/S; Ryesgade 3, P.O. Box 5020, DK-8000 Aarhus C (DK).</p>	<p>(81) Designated States: AE, AL, AM, AT, AT (Utility model), AU, AZ, BA, BB, BG, BR, BY, CA, CH, CN, CU, CZ, CZ (Utility model), DE, DE (Utility model), DK, DK (Utility model), EE, EE (Utility model), ES, FI, FI (Utility model), GB, GD, GE, GH, GM, HR, HU, ID, IL, IN, IS, JP, KE, KG, KP, KR, KZ, LC, LK, LR, LS, LT, LU, LV, MD, MG, MK, MN, MW, MX, NO, NZ, PL, PT, RO, RU, SD, SE, SG, SI, SK, SK (Utility model), SL, TJ, TM, TR, TT, UA, UG, US, UZ, VN, YU, ZA, ZW, ARIPO patent (GH, GM, KE, LS, MW, SD, SL, SZ, UG, ZW), Eurasian patent (AM, AZ, BY, KG, KZ, MD, RU, TJ, TM), European patent (AT, BE, CH, CY, DE, DK, ES, FI, FR, GB, GR, IE, IT, LU, MC, NL, PT, SE), OAPI patent (BF, BJ, CF, CG, CI, CM, GA, GN, GW, ML, MR, NE, SN, TD, TG).</p> <p>Published With international search report. Before the expiration of the time limit for amending the claims and to be republished in the event of the receipt of amendments. In English translation (filed in Danish).</p>	

(54) Title: APPARATUS AND METHOD OF REGULATING ROOM HEATING



(57) Abstract

The invention relates to a heat regulation device for the regulation of the temperature in a room by heating means in response to at least one room temperature representing signal and at least one predetermined or user-settable reference temperature, said heat regulation device being adapted to control heating means, said heat regulation device being adapted to adjust or weight the reference temperature in response to one or more additional temperature representing signals fed to the device.

FOR THE PURPOSES OF INFORMATION ONLY

Codes used to identify States party to the PCT on the front pages of pamphlets publishing international applications under the PCT.

AL	Albania	ES	Spain	LS	Lesotho	SI	Slovenia
AM	Armenia	FI	Finland	LT	Lithuania	SK	Slovakia
AT	Austria	FR	France	LU	Luxembourg	SN	Senegal
AU	Australia	GA	Gabon	LV	Latvia	SZ	Swaziland
AZ	Azerbaijan	GB	United Kingdom	MC	Monaco	TD	Chad
BA	Bosnia and Herzegovina	GE	Georgia	MD	Republic of Moldova	TG	Togo
BB	Barbados	GH	Ghana	MG	Madagascar	TJ	Tajikistan
BE	Belgium	GN	Guinea	MK	The former Yugoslav Republic of Macedonia	TM	Turkmenistan
BF	Burkina Faso	GR	Greece	ML	Mali	TR	Turkey
BG	Bulgaria	HU	Hungary	MN	Mongolia	TT	Trinidad and Tobago
BJ	Benin	IE	Ireland	MR	Mauritania	UA	Ukraine
BR	Brazil	IL	Israel	MW	Malawi	UG	Uganda
BY	Belarus	IS	Iceland	MX	Mexico	US	United States of America
CA	Canada	IT	Italy	NE	Niger	UZ	Uzbekistan
CF	Central African Republic	JP	Japan	NL	Netherlands	VN	Viet Nam
CG	Congo	KE	Kenya	NO	Norway	YU	Yugoslavia
CH	Switzerland	KG	Kyrgyzstan	NZ	New Zealand	ZW	Zimbabwe
CI	Côte d'Ivoire	KP	Democratic People's Republic of Korea	PL	Poland		
CM	Cameroon	KR	Republic of Korea	PT	Portugal		
CN	China	KZ	Kazakstan	RO	Romania		
CU	Cuba	LC	Saint Lucia	RU	Russian Federation		
CZ	Czech Republic	LI	Liechtenstein	SD	Sudan		
DE	Germany	LK	Sri Lanka	SE	Sweden		
DK	Denmark	LR	Liberia	SG	Singapore		
EE	Estonia						

Apparatus and method of regulating room heating

State of the art

5 The invention relates to an apparatus as defined in the introductory portions of claims 1 and 9 and to a method as stated in the introductory portions of claims 6, 7 and 8.

10 Many different regulation principles of a more or less complicated nature are known in connection with space heating. An example of a heating regulation principle is known in heating systems in which a room sensor and a floor sensor measure room temperatures which are subse-
15 quently used as a basis for a regulation of the room temperature. The desired room temperature can be set by a user, following which the system ensures that both floor temperature and room temperature are above or equal to the values set by the user. The determination of the con-
20 trol parameters for the floor sensors is a fixed constant relationship which is statically associated with the room temperature set by the user. An advantage of the above-mentioned system is that the user only has to set one value, i.e. the room temperature, with the purpose of
25 achieving a given temperature at the floor sensor as well as the room sensor.

A drawback of the system of the above-mentioned type is that it does not allow for the circumstance that the com-
30 fort criteria of persons in the room concerned do not depend uniquely on the threshold values. This leads to several drawbacks, one being that the system frequently "overregulates" in several situations so that the consumption of energy is increased inexpediently. Alterna-
35 tively, depending on calibration and control strategy, the system will perform a control which results in

"overregulation" in some situations and "underregulation" in other cases, thereby reducing the comfort as the temperature is felt to be too low.

5 The object of the invention is to provide a space heating system which provides a pleasant and comfortable room temperature, it being another object of the invention to achieve an energy-saving heating strategy.

10 **Summary of the invention**

The invention relates to a heat regulation device for the regulation of the temperature in a room by heating means in response to at least one room temperature representing signal and at least one predetermined or user-settable
15 reference temperature, said heat regulation device being adapted to control heating means, said heat regulation device being adapted to adjust or weight the reference temperature or the room temperature representing signal directly or indirectly in response to one or more addi-
20 tional temperature representing signals fed to the device.

A very advantageous regulation of space heating is obtained according to the invention. A very important ad-
25 vantage of the invention is that the heat regulation makes it possible to provide a comfort temperature which is pleasant for the persons who might be present in the heated room. Instead of weighting entered or predefined "compulsory criteria", the invention rather provides an
30 advantageous heat regulation which takes it into account that the mean temperature of the room "goes" vertically up and down in the room, depending on the current need for energy supply to the room, so that the comfort for the persons present in the room is not only determined on
35 the basis of a fixed temperature, but can be weighted relatively to a temperature measured in the vicinity of

the floor of the room, the current energy need and the room temperature.

It has thus been found that the comfort is improved considerably for persons present in a room which is heat regulated in accordance with the invention.

A further and very important advantage of the invention is that the improved comfort is achieved with a strongly reduced energy consumption. The saving should be seen in the light of the fact that, to a great extent, the human body does not perceive lower temperatures in the higher strata of air as being unpleasant if reasonably high temperatures occur in the vicinity of the floor. According to the invention, this fact makes it possible to down-weight the room temperatures desired by the user and to save energy thereby without this being at the expense of the heating comfort.

A further aspect of the invention is that the regulation strategy may be implemented by means of two sensors placed in the room, i.e. a room temperature sensor and a floor temperature sensor, in contrast to other systems which require the use of an outdoor sensor. As a result, a regulation system according to the invention is simple and inexpensive to manufacture, just as the mounting and putting-into-service costs are limited because of the limited physical extent of the system.

An important advantage according to the invention is thus that, in dependence on the surrounding environment, i.e. e.g. type of insulation, degree of ventilation, etc., the properties of the room in terms of temperature can be derived from the algorithm without using more than two outdoor sensors in the optimum embodiment.

The room temperature representing signal is typically measured by one or more sensors which are placed 5-10 cm down in the floor. Other positions, however, are also possible.

5

When additionally, as stated, the heating means are floor heating means, a special advantage is achieved according to the invention, since the heating strategy gives by far the best result with low-positioned heating means which radiate uniformly in the room. In contrast to vector heating, a quite special synergy must be achieved when the invention is used for the control of floor heating. Thus it is possible to use very few sensors in each room which is to be heated, e.g. one onboard sensor for measuring room temperature and one external sensor for measuring floor temperature or a temperature near the floor. In addition, a really good comfort is achieved, since the temperature distribution can be controlled uniformly over the entire floor face of the room.

10
15
20

Heating means broadly mean heating means such as electrical heating wires, heating pipes, etc.

Drawing

25 The invention will be described more fully below with reference to the figures, in which

fig. 1 shows a room with a heating system according to the invention, and

30

figs. 2A-2C show how the temperature is regulated in accordance with an example according to the invention.

Example

35 Fig. 1 shows a room 1 with a floor 2. Heating means 3 in the form of electrical heating wires are embedded in the

floor. It will be appreciated that other heating means may be used in a corresponding manner.

The heating means 3 are controlled by a heat regulator 4 having an onboard temperature sensor (not shown) which currently measures the room temperature. An advantageous mounting height according to an example of the invention may e.g. be about 1 m, typically determined by the height at which the user wants to use the regulator. The regulator 4 is additionally connected with a temperature sensor 6 which measures the temperature in the vicinity of the floor 2. This sensor may advantageously be placed 5-10 cm down in the floor. Positions on or just above the floor are also possible.

15

It should be stressed in this connection that the position of the floor temperature sensor according to the invention is very important since the basis for the regulation is precisely this sensor, while the room temperature sensor may be considered as being secondary.

20

The reason is that the human body is particularly temperature-sensitive at the feet and around the ankles, for which reason the control strategy is developed on the basis of this assumption, and temperature signals picked up at the floor are therefore given a particularly high weight relative to the room temperature.

25

Signal-wise, the temperature sensor 6 is connected to the heat regulator 4 wirelessly or via fixed cabling (not shown).

30

Finally, the heat regulator 4 is provided with a button 7 for setting a user-defined room temperature or more particularly comfort temperature.

35

The functionality of a heat regulator according to the invention will be described more fully below.

5 Figs. 2A-2C show an example of how a heat regulator according to the invention is arranged.

The regulator 4 is arranged in accordance with a very simple embodiment, the floor temperature measured by the sensor 6 and the room temperature measured by the onboard sensor being incorporated as simple on/off values. That is the heating means 3 are activated if both of the two determined threshold values have been reached. According to the invention, however, an additional internal weighting of the desired room temperature programmed by the user is carried out in response to the measured floor temperature. This weighting will be illustrated below with reference to figs. 2A-2C.

20 In fig. 2A, the floor temperature has been measured to be +20 °C by the sensor 6. The room temperature has likewise been measured to be +20 °C by the onboard sensor (not shown) in the regulator 4.

25 An outdoor state that might e.g. provide the shown situation may e.g. be +10 °C.

The algorithm according to the invention performs no correction of the threshold values, but activates the heating means 3 in a simple manner if both threshold values have not been exceeded.

35 In fig. 2B, the floor temperature has been measured to be +22 °C by the sensor 6, and the room temperature threshold value has therefore been weighted internally in the regulator 4 by -0.2 °C for each 1 °C the floor temperature exceeds +20 °C.

The automatically adjusted value of the value of $+20^{\circ}\text{C}$ set by the user has thereby been reduced to $+19.6^{\circ}\text{C}$.

5 The algorithm according to the invention thus performs a correction of the room temperature threshold value and activates the heating means 3 in a simple manner if both threshold values have not been exceeded, i.e. $+19.6^{\circ}\text{C}$ and 22°C .

10

An outdoor state that might e.g. provide the shown situation may e.g. be 0°C .

In fig. 2C, the floor temperature has been measured to be
15 $+24^{\circ}\text{C}$ by the sensor 6, and the room temperature threshold value has therefore been weighted internally in the regulator 4 by -0.2°C for each 1°C the floor temperature exceeds $+20^{\circ}\text{C}$.

20 The automatically adjusted value of the value of $+20^{\circ}\text{C}$ set by the user has thereby been reduced to $+19.2^{\circ}\text{C}$.

The algorithm according to the invention thus performs a correction of the room temperature threshold value and
25 activates the heating means 3 in a simple manner if both threshold values have not been exceeded, i.e. $+19.2^{\circ}\text{C}$ and 24°C .

An outdoor state that might e.g. provide the shown situation
30 may e.g. be -10°C .

Many other algorithms, linear as well as unlinear ones, may be applied within the framework of the invention as long as the room temperature signal or the reference temperature is weighted in response to the floor sensor temperature.
35

Patent Claims

1. A heat regulation device (4) for the regulation of the temperature in a room by heating means in response to at least one room temperature representing signal and at least one predetermined or user-settable reference temperature, said heat regulation device being adapted to control heating means (3), characterized in that the heat regulation device (4) is adapted to adjust or weight the reference temperature or room temperature representing signals directly or indirectly in response to one or more additional temperature representing signals fed to the device.
2. A heat regulation device according to claim 1, characterized in that the additional temperature representing signal or signals represent a temperature which is measured in or on the floor of the room.
3. A heat regulation device according to claim 2, characterized in that the additional temperature representing signal or signals are measured 0 - 10 cm down in the floor (2) of the room.
4. A heat regulation device according to claims 1-3, characterized in that the device comprises an internal sensor for measuring the room temperature and an entry to a remote sensor which measures the floor temperature.
5. A heat regulation device according to claims 1-4, characterized in that the heating means are floor heating means.
6. A method for the regulation of space heating on the basis of a preselected reference temperature (pl) and

heating means (floor), the regulation of the heating means being controlled in response to the reference temperature (p1) and at least one measured room temperature, c h a r a c t e r i z e d in that the reference temperature (p1) is weighted in response to at least one measured floor temperature.

7. A method for the regulation of the temperature in a room (1) on the basis of a user-settable or predefined room temperature and a dynamically measured room temperature, c h a r a c t e r i z e d in that the user-settable or predefined room temperature is internally regulated dynamically in response to the floor temperature of the room.

15

8. A method for the regulation of room temperature by heating means as well as at least one room temperature representing signal, c h a r a c t e r i z e d in that the room temperature is regulated in response to at least one dynamically varying reference point, the variation of the reference point being determined by at least one additional room temperature representing signal.

9. A regulation device for the control of floor heating means (3), said regulation device being adapted to control the heating means (3) by means of suitable control signals, said control signals being established in response to temperature sensor signals measured at a distance from the floor and temperature sensor signals measured in or on the floor, said control signals being additionally established relative to at least one settable room reference temperature, c h a r a c t e r i z e d in that the settable room reference temperature is weighted dynamically in response to temperature sensor signals measured in the vicinity of the floor.

35

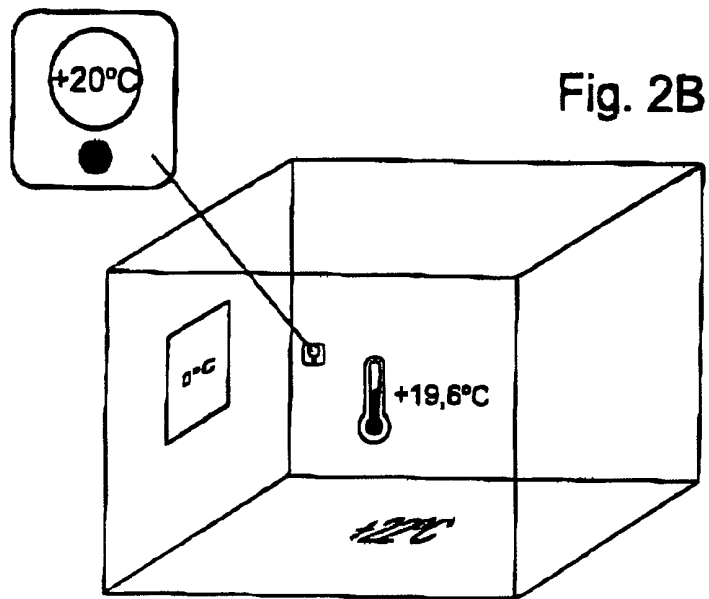
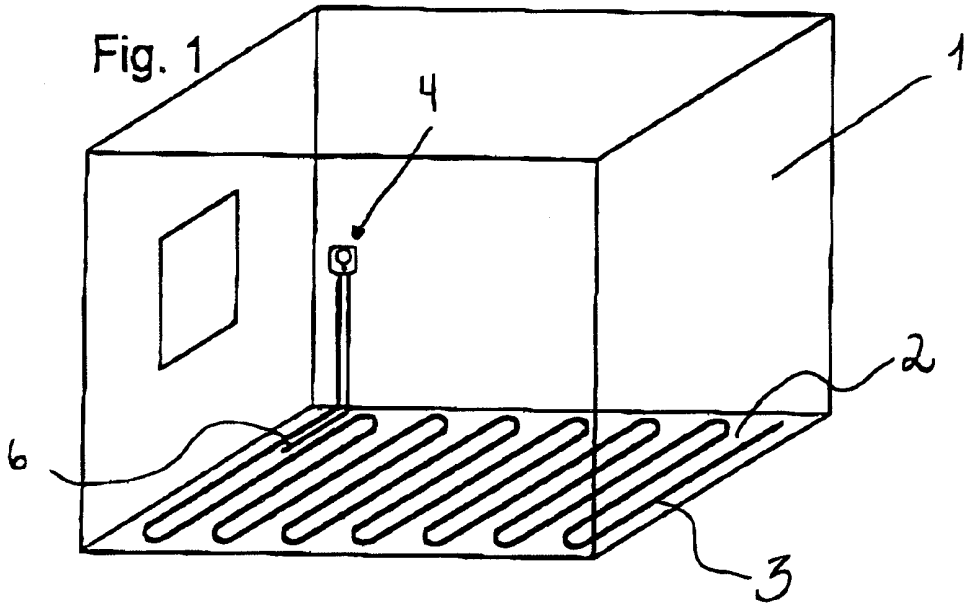

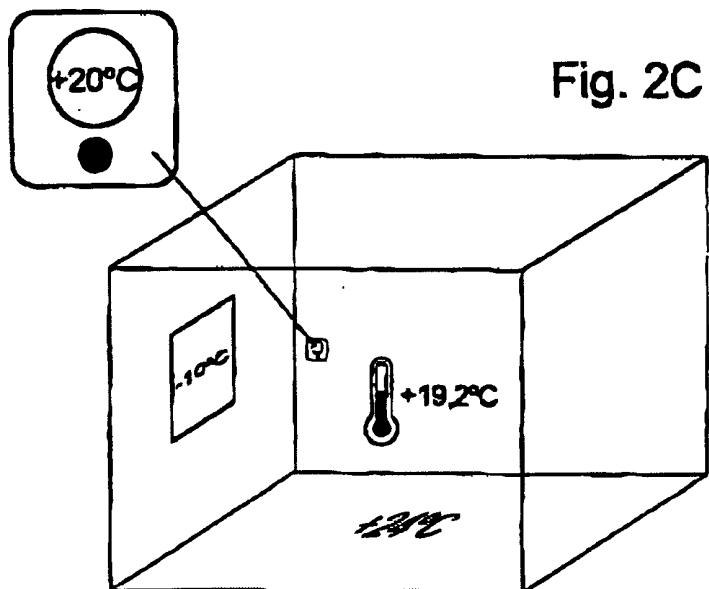
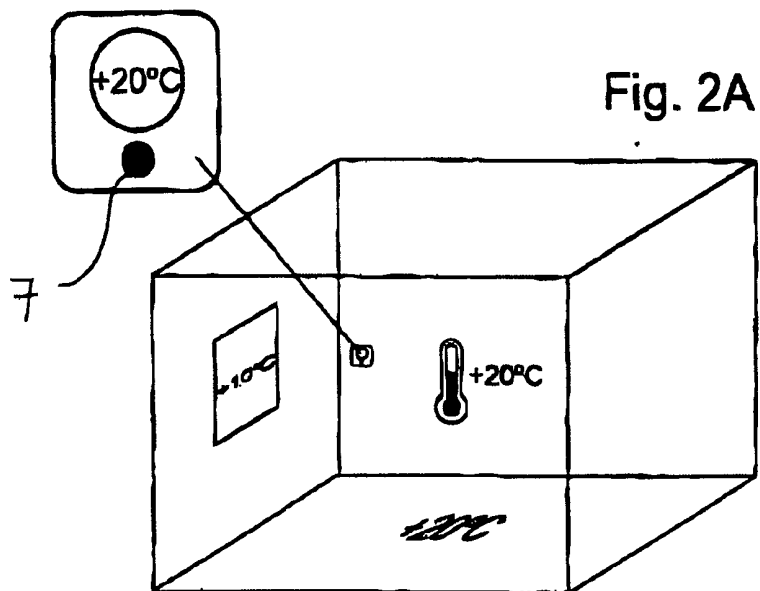

INTERNATIONAL SEARCH REPORT

International application No.

PCT/DK 99/00428

A. CLASSIFICATION OF SUBJECT MATTER		
IPC7: G05D 23/19 According to International Patent Classification (IPC) or to both national classification and IPC		
B. FIELDS SEARCHED		
Minimum documentation searched (classification system followed by classification symbols)		
IPC7: G05D, F24D		
Documentation searched other than minimum documentation to the extent that such documents are included in the fields searched		
SE,DK,FI,NO classes as above		
Electronic data base consulted during the international search (name of data base and, where practicable, search terms used)		
C. DOCUMENTS CONSIDERED TO BE RELEVANT		
Category*	Citation of document, with indication, where appropriate, of the relevant passages	Relevant to claim No.
X	US 5170936 A (TORU KUBO ET AL), 15 December 1992 (15.12.92), column 2, line 43 - column 6, line 52, figures 1-10B, abstract --	1-9
X	US 4089462 A (GEORGE J. BRADFORD), 16 May 1978 (16.05.78), column 3, line 26 - column 8, line 21, figures 1-3, abstract --	1
X	US 5148977 A (YOZO HIBINO ET AL), 22 Sept 1992 (22.09.92), column 3, line 51 - column 10, line 21, figures 1-9, abstract -- -----	1
<input type="checkbox"/> Further documents are listed in the continuation of Box C. <input checked="" type="checkbox"/> See patent family annex.		
* Special categories of cited documents: "A" document defining the general state of the art which is not considered to be of particular relevance "B" earlier document but published on or after the international filing date "L" document which may throw doubts on priority claim(s) or which is cited to establish the publication date of another citation or other special reason (as specified) "O" document referring to an oral disclosure, use, exhibition or other means "P" document published prior to the international filing date but later than the priority date claimed "T" later document published after the international filing date or priority date and not in conflict with the application but cited to understand the principle or theory underlying the invention "X" document of particular relevance: the claimed invention cannot be considered novel or cannot be considered to involve an inventive step when the document is taken alone "Y" document of particular relevance: the claimed invention cannot be considered to involve an inventive step when the document is combined with one or more other such documents, such combination being obvious to a person skilled in the art "&" document member of the same patent family		
Date of the actual completion of the international search		Date of mailing of the international search report
23 December 1999		03 -01- 2000
Name and mailing address of the ISA/ Swedish Patent Office Box 5055, S-102 42 STOCKHOLM Facsimile No. + 46 8 666 02 86		Authorized officer Roland Landström/mj Telephone No. + 46 8 782 25 00

INTERNATIONAL SEARCH REPORT

Information on patent family members

02/12/99

International application No.

PCT/DK 99/00428

Patent document cited in search report	Publication date	Patent family member(s)	Publication date
US 5170936 A	15/12/92	JP 3043693 A	25/02/91
US 4089462 A	16/05/78	NONE	
US 5148977 A	22/09/92	JP 2510333 B	26/06/96
		JP 4052440 A	20/02/92