

(No Model.)

C. N. HUTCHINS.
COTTON CULTIVATOR.

No. 365,073.

Patented June 21, 1887.

Fig. 1.

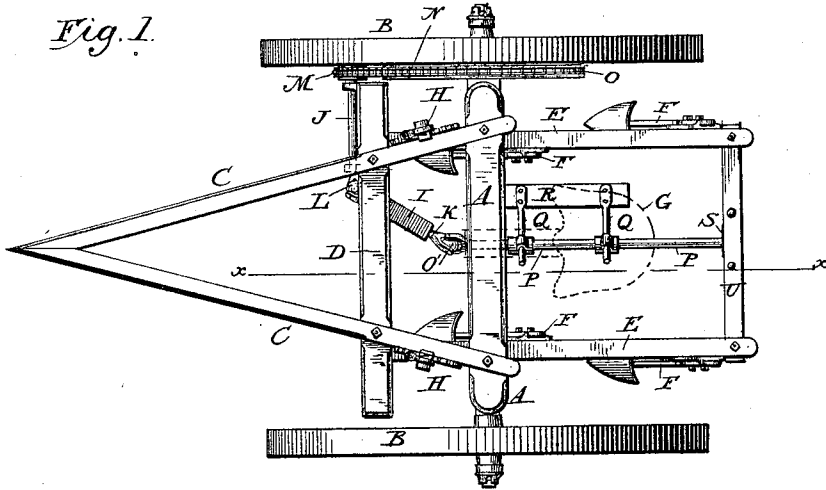

Fig. 2.
ON LINE X-X

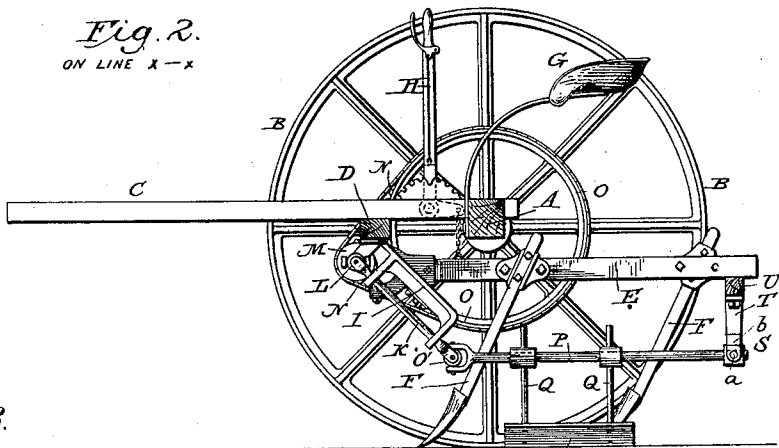

Fig. 3.

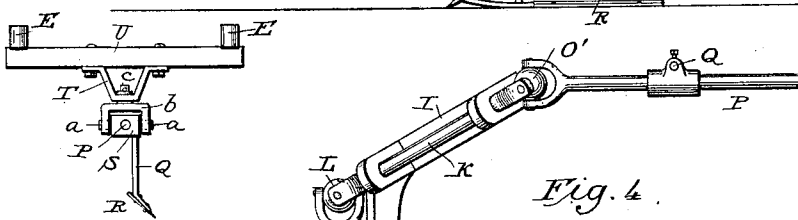
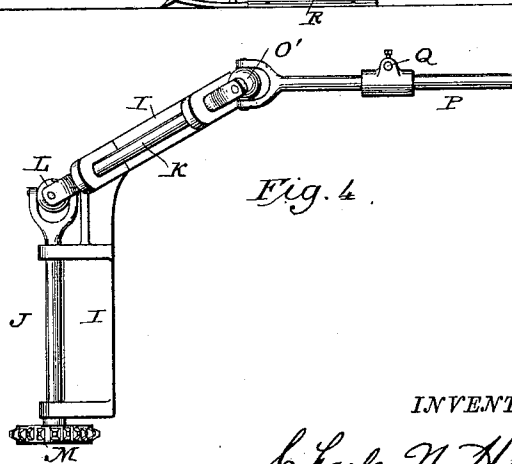

Fig. 4.



WITNESSES
Sidney P. Hollingsworth
J. M. Kennedy

INVENTOR
Charles N. Hutchins
 By *P. T. Dodge*
 Attorney

UNITED STATES PATENT OFFICE.

CHARLES NELSON HUTCHINS, OF DUPREE, ASSIGNOR OF ONE THIRD TO
PHILIP H. GERHARD, OF AUSTIN, TEXAS.

COTTON-CULTIVATOR.

SPECIFICATION forming part of Letters Patent No. 365,073, dated June 21, 1887.

Application filed August 25, 1886. Renewed May 11, 1887. Serial No. 237,842. (No model.)

To all whom it may concern:

Be it known that I, CHARLES NELSON HUTCHINS, of Dupree, in the county of Hays and State of Texas, have invented certain Improvements in Cotton-Cultivators, of which the following is a specification.

My invention relates to that class of machines commonly known as "cotton-cultivators" or "cotton-choppers," in which the cultivator-blades are attached to a horizontal shaft and arranged to revolve in a vertical direction; and it consists in the peculiar construction and arrangement of parts hereinafter specified.

In the accompanying drawings, Figure 1 represents a top plan view of my machine, the driver's seat being shown in dotted lines. Fig. 2 is a vertical longitudinal section of the machine on the line *x x*. Fig. 3 is a rear elevation of the bearing for the rotary shaft and the adjacent parts. Fig. 4 is a bottom plan view of the device for operating the rotary shaft.

In the drawings, A represents an axle mounted at its ends in two ground-wheels, B, and bolted firmly to the rear ends of two forwardly-extending converging bars, C, which form a draft-pole or tongue. At a suitable point in front of the axle a cross-bar, D, is bolted firmly to the bars C, and provided with depending arms or brackets, to the lower end of which are attached the rearwardly-extending beams or drag-bars E, each provided with two shovel-carrying standards, F. The joints by which the drag-bars are connected to the frame are similar to those in common use in cultivators, and are adapted to permit the rear ends of the drag-bars to move both vertically and horizontally. In the middle of the frame, in rear of the axle, there is mounted a driver's seat, G, and on each side of the frame, in convenient reach of the driver, there is a hand-lever, H, connected by a rod or chain to the adjacent drag-bar, whereby the bars may be raised and lowered at will. The drag-bars are in such relation to the driver's seat that he may control their lateral movement by placing his feet thereon.

The foregoing parts are constructed and organized in substantially the same manner as

in the straddle-row cultivators now in use, and they are not claimed as of my invention.

I bolt to the under side of the frame, at the forward end, a plate or casting, I, provided with bearings, which support the two shafts J and K, connected by a universal joint, L. The shaft J lies parallel with the axle of the machine, and carries at its outer end a sprocket-wheel, M, driven by a chain, N, from a wheel or ring, O, secured for the purpose to the inner side of one of the ground-wheels. The secondary shaft K extends inward in a direction oblique to the axle, and terminates at the middle of the machine at a point considerably below the axle, and at its rear end it is connected by a universal joint, O', to a horizontal shaft, P, provided with adjustable arms Q, carrying at their outer ends a blade, R. The rear end of the shaft P is sustained in a box or bearing, S, connected by a universal joint to a standard, T, projecting downward from a bar, U, extending from one of the drag-bars to the other and pivoted therein, as shown. By means of the universal joints and wheels a rapid rotary motion is imparted to the shaft P and its blade R, the latter being thus caused to act upon the soil between the paths traversed by the shovels. Owing to the fact that the rear end of the shaft P is supported through the intermediate devices from the drag-bar, the shaft and its cutter will follow both the lateral and vertical movements of the drag-bars and shovel. This arrangement enables the cutter to occupy a constant relation to the shovels, so that the latter may be moved laterally as required to follow the line of the plants. By mounting the rear end of the shaft P in the box jointed to the standard it is firmly supported, but prevented from binding or cramping in consequence of its lateral and vertical motion.

In the drawings I have represented the box S as supported by horizontal journals *a* in a forked arm, *b*, having a vertical spindle, *c*, mounted in the bracket T; but any other form of universal joint adapted for the purpose may be substituted.

The joint O' serves the twofold purpose of supporting the forward end of the shaft P and of imparting the rotary motion thereto, and

this while permitting the rear end of the shaft to move freely in all directions.

It will be observed that the parts to which my invention relates are of such character that they may be applied to existing machinery without necessitating change or alteration therein in any other respect.

I am aware that cultivators have been constructed with horizontal rotary shafts provided with blades or cutters, and this I do not broadly claim, my invention residing in the particular combination and arrangement of parts hereinafter recited.

Having thus described my invention, what I claim is—

1. In a cotton chopper, the combination of the wheeled frame, the two laterally and vertically movable drag-bars jointed thereto, and each provided with shovels, the horizontal rotary shaft P, lying between the drag-bars and provided with a blade, R, arranged to revolve between the shovels of the respective beams, the transverse shaft J, mounted on the frame and connected by driving devices with the ground-wheel, and the intermediate shaft, K, connected to the shafts J and P by universal joints, as described.

2. In a cotton chopper, the combination of

the following members: the wheeled main frame, two drag-bars jointed to said frame to swing vertically and laterally, a horizontal shaft provided with a blade or cutter, R, arranged to revolve and act upon the earth between the shovels of the respective beams, a cross-bar connecting the beams and provided with a swiveled bearing for the rear end of the rotary shaft, a driving-shaft, J K, mounted in fixed bearings on the frame and jointed at its rear end to the shaft P, and the driving-gear connecting said shaft I with the ground-wheel, substantially as described.

3. The wheeled frame, the drag-bars, and the cross-bar connecting the drag-bars, in combination with the shafts J, K, and P, jointed together as described, the cutter attached to the last-named shaft, and the two sprocket-wheels and their connecting-chain for imparting motion to the shaft.

In testimony whereof I hereunto set my hand, this 6th day of August, 1886, in the presence of two attesting witnesses.

CHAS. NELSON HUTCHINS.

Witnesses:

L. W. FRANKS,
JON. N. GOFORTH.