

W. F. WAGNER & W. E. SHIELS.  
 LOCK-OUT FOR PARTY LINE TELEPHONES.  
 APPLICATION FILED FEB. 26, 1908.

914,468.

Patented Mar. 9, 1909.

2 SHEETS—SHEET 1.

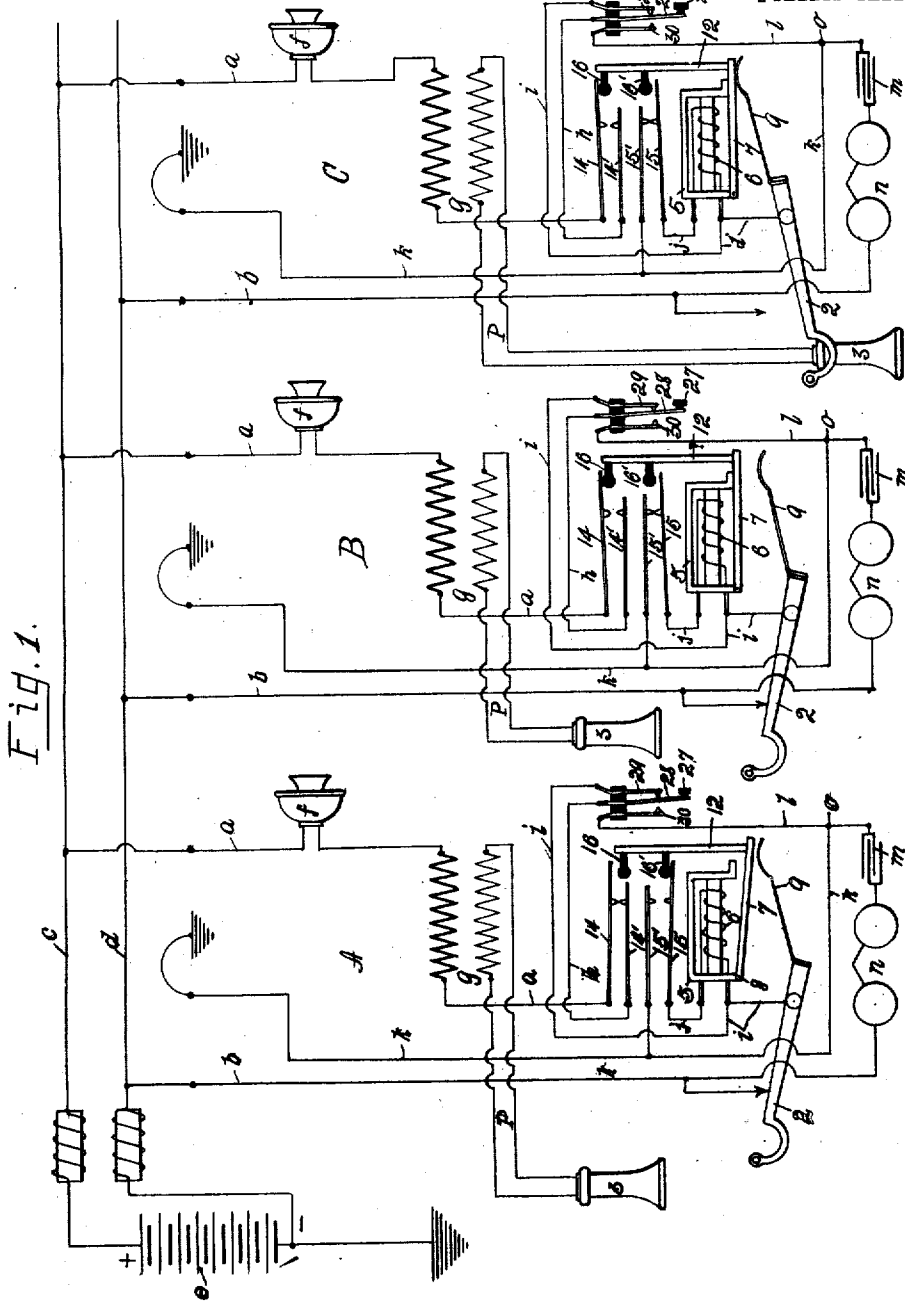

WITNESSES:

*D. C. Walter*  
*Hazel B. Witt*

INVENTORS:

*William F. Wagner,*  
*William E. Shiels,*  
*By Owen & Owen,*  
*Attys.*

W. F. WAGNER & W. E. SHIELDS.  
 LOCK-OUT FOR PARTY LINE TELEPHONES.  
 APPLICATION FILED FEB. 26, 1908.

914,468.

Patented Mar. 9, 1909.  
 2 SHEETS—SHEET 2.

Fig. 2.

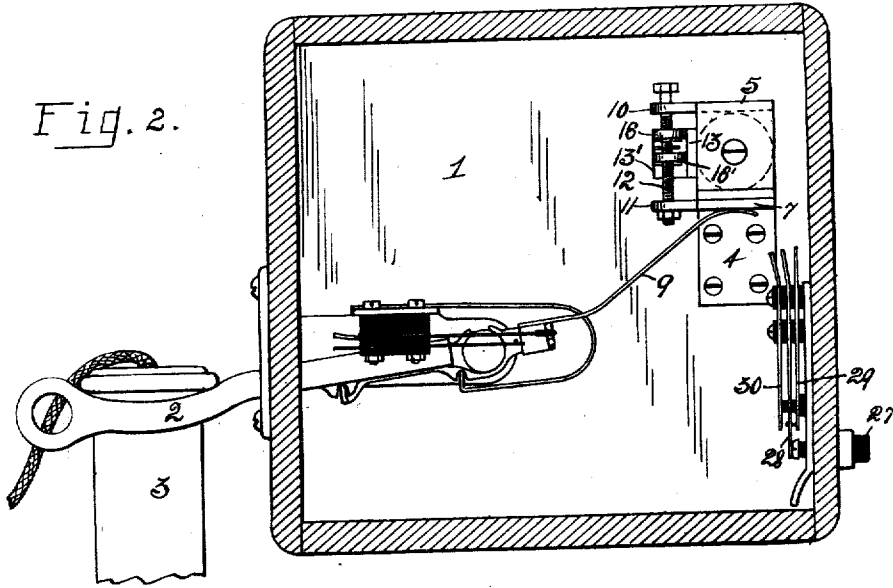

Fig. 3.

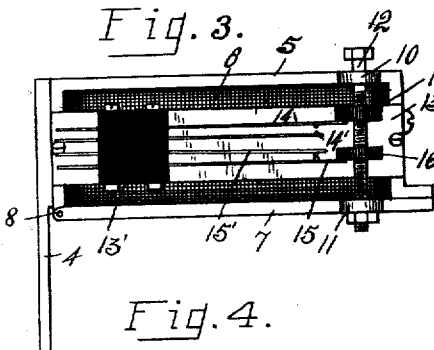

Fig. 4.

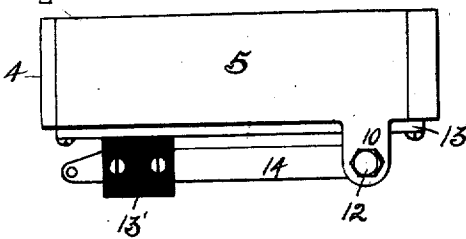
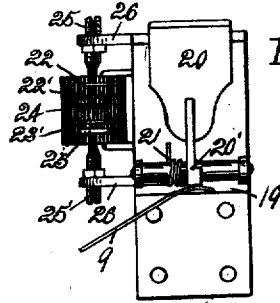

Fig. 5.



Fig. 6.



WITNESSES:

*D. C. Watter*  
*Hazel B. Kutt*

INVENTORS:

*William F. Wagner,*  
*William E. Shields,*  
 By *Owen & Owen,*  
*Their attys.*

# UNITED STATES PATENT OFFICE.

WILLIAM F. WAGNER, OF DETROIT, MICHIGAN, AND WILLIAM E. SHIELDS, OF TOLEDO, OHIO,  
ASSIGNORS TO THE GRAVITY LOCKOUT COMPANY, OF TOLEDO, OHIO, A CORPORATION  
OF OHIO.

## LOCK-OUT FOR PARTY-LINE TELEPHONES.

No. 914,468.

Specification of Letters Patent.

Patented March 9, 1909.

Application filed February 26, 1908. Serial No. 417,942.

*To all whom it may concern:*

Be it known that we, WILLIAM F. WAGNER and WILLIAM E. SHIELDS, citizens of the United States, and residents of Detroit, in the county of Wayne and State of Michigan, and Toledo, in the county of Lucas and State of Ohio, respectively, have invented a certain new and useful Lock-Out for Party-Line Telephones; and we do hereby declare the following to be a full, clear, and exact description of the invention, such as will enable others skilled in the art to which it appertains to make and use the same, reference being had to the accompanying drawings, and to the characters of reference marked thereon, which form a part of this specification.

Our invention relates to telephone apparatus, and particularly to devices for use in party-line systems whereby when one telephone on a party-line is in use all other telephones are automatically cut out of service so that no one on the line can listen or talk to the party first to take his receiver from the hook, except at the will of such first party.

The object of our invention is the provision of a simple and highly efficient device of this class, which can be used in connection with any central energy telephone plant, can be tested at the station where it is installed without going to another instrument installed on the same line, and which does not need an additional condenser in the telephone instrument, as is necessary with other devices of this nature, but is operated by the condenser of the instrument in connection with which it is installed, thus materially enhancing the practicability and commercial value thereof.

In the use of the lock-out devices heretofore employed considerable difficulty has been experienced due to the circuits in which they are disposed being permanently grounded. An object of our invention is to obviate this difficulty by the provision of a device of this character, which eliminates the grounding of any telephone on the line when all of the receivers of such telephones are on their hooks, and which also releases the ground from a telephone when the receiver is off the hook and the party is talking.

Further objects as well as the operation,

and arrangement of the parts 55 of the invention are fully described in the following specification, and illustrated in the accompanying drawings, in which,—

Figure 1 is a diagram of a party-line circuit with three telephones bridged across the main. Fig. 2 is a vertical section of a phone box from which the receiver hook projects illustrating the relative arrangement of parts of our invention therein. Figs. 3 and 4 are side and top views, respectively, of the electro-magnet and armature employed in connection with our invention, with the associated contact parts, and Figs. 5 and 6 are side and end views, respectively, of a modified form of the electro-magnet and armature.

Referring to the drawings, 1 designates the usual telephone box through one side of which the receiver-hook 2 projects, and 3 the receiver. The receiver-hook is connected in the usual or any convenient manner to the circuit wires to adapt it to open and close the circuit as it is lowered or raised.

Projecting outwardly from the rear wall of the box 1, as from a wall piece 4, is a magnet 5 preferably of horse-shoe form, which is of suitable shape to receive the energizing coil 6 with the ends of its core secured to the legs of the magnet. An armature-plate 7 is pivoted at one end to one pole of the magnet, as at 8, and has its other end extended in position to adapt it, when raised, to have contact with the other pole end so that it cooperates with the magnet to form a closed magnet circuit around the coil. A spring-finger 9 projects from the inner end of the receiver-hook in position to have contact with the free end of the armature 7 to cause said armature to be held in closed contact with the magnet when the receiver is on its hook, as shown. Connecting the ears 10 and 11, which project laterally from the magnet top and armature, respectively, in superimposed relation, is the bolt or pin 12, which has its lower end threaded or otherwise adjustably secured in the lower ear 11 and its upper end working loosely through the ear 10 and headed without such ear to permit the armature and magnet to have limited relative movements. Carried near the rear end of the magnet, as by a plate 13 secured thereto, is an insulation block 13' from which the two sets of con-

tact springs 14, 14' and 15, 15' insulatingly project with their free ends disposed contiguous to the pin 12. The free ends of the outer springs 14 and 15 project beyond the ends of the inner springs 14' and 15' to adapt them to be engaged by insulation buttons or projections 16 and 16', respectively, which are adjustably carried by the pin 12. The buttons or projections 16 and 16' are so relatively adjusted on the pin 12 and coact with the spring ends in such manner that a longitudinal movement of the pin in one direction causes or permits one set of springs to make and the other to break contact, and vice versa when the pin is moved in the other direction.

It is apparent that the manner of coaction of the buttons 16 and 16' with the springs 14 and 15 may either be such as to cause positive movements of the springs in both directions of movement of the pin, or positive movements of the springs in only one direction of movement of the pin while the movements of the springs in the other direction are influenced by the spring action thereof. In the arrangement of the parts shown, the dropping of the free end of the armature 7 and attached pin 12 causes the upper set of springs 14, 14' to make contact and the lower set 15, 15' to break contact, and vice versa when raised to form a closed magnetic circuit with the magnet 5.

In Figs. 5 and 6, which shows a modified form of the electro-magnet and armature, 17 designates the magnet, which has its poles extending horizontally, 18 the energizing coil, which has the rear end of its core pivoted within the magnet to the rear end thereof, as at 18', and 19 the lower end of the armature, which is fixed to the outer end of the coil core and has its lower end angled to make contact with the end of the lower pole of the magnet when the coil is raised on its pivot, as shown. Pivoted to the armature piece 19, as at 19', is the upper armature piece 20, which, when the coil is in elevated position is intended to have contact with the upper pole end to cooperate with the lower piece 19 to form a closed magnetic circuit around the coil. The armature piece 20 has its upper end preferably angled to engage over the top of the upper pole piece, and its lower end provided with an arm 20' with which the spring-finger 9 of the receiver-hook coacts to hold the coil elevated and the armature piece 20 in contact with its pole when the receiver is on its hook. The angling of the end of the armature piece 20 over the pole end tends to support the coil in elevated position, and a spring 21 encircles the pivot of said armature piece and acts on the arm 20' thereof to throw such angled end out of engagement with the pole when the spring-finger 9 lowers, thus permitting the outer coil end

to lower and the armature pieces to move therewith out of contact with their respective poles. The two sets of contact springs 22, 22' and 23—23' project from an insulation-block 24, which is carried at the rear end of the coil-core at one side thereof, and lie along side of the coil, as shown. Contact is alternately made and broken between the springs of the two sets as the coil is lowered and raised due to the action thereof of the pins 25 and 25'. These pins are made of any suitable insulating material and are threaded or otherwise adjustably secured to ears 26 projecting laterally from the pole pieces of the magnet, the lower pin 25' having its inner end projected upwardly through an opening in the lower spring 23 so as to coact with its companion to break contact between them when the coil lowers, and the upper pin 25 having its inner end projected downwardly through openings in both springs 22, 22' and headed to engage the under side of the lower spring of the set whereby to move it against its tension in contact with its companion when the coil and attached parts are lowered.

It will be apparent that the armature in both constructions shown operate by gravity to move to open position relative to their magnets when the magnets become dead, thus providing what may be termed a gravity lock-out device. This movement of the armature may, if desired, be accelerated by the action of a spring or other suitable means apparent to those skilled in the art.

27 designates a push-button, which projects through the side of the box 1, with its inner end in contact with the free end of a spring contact 28. This spring is secured to the interior of the box in a suitable manner between two contact pieces 29 and 30, from which it is insulated, and is intended to normally have contact with one piece and to be moved to break such contact and make contact with the other piece when the button is pushed.

Referring to Fig. 1, A, B and C designate three party-line telephones, each of which has its leads *a* and *b* connected in the usual manner to the main line wires *c* and *d*, respectively, the former of which line wires leads from the positive side and the latter from the negative side of the battery *e* of the plant. The positive lead *a* passes to the transmitter *f* and one coil of the induction coil *g* in the usual manner and connects to the contact spring 14 in the instrument. When the springs 14 and 14' are in contact a circuit is closed through the wire *h* to the contact spring 28, associated with the push button 27, thence through the contact-piece 29, when the spring 28 is in contact therewith, and the wire *i* connected to said piece. The wire *i* connects with one of the contacts of the receiver-hook 2 and the lead *b* to the other

contact in the usual manner, whereby a lowering of the hook breaks and a raising thereof closes connection between said wires. It is thus seen that the primary or talking circuit has in series the battery *e*, main line wires *a*, *d*, lead *a*, transmitter *f*, the primary of the induction coil *g*, contacts 14, 14', wire *h*, contacts 28, 29, wire *i*, receiver 2 and lead *b*. The wire *i* also has a branch leading to one end of the coil *g* of the electro-magnet. The other end of said coil is connected by a wire *j* to the spring-contact 15 associated with the electro-magnet, while the companion spring 15' is connected to the ground wire *k*, thus forming a closed grounding circuit when the springs 15, 15' have contact. The contact piece 30, associated with the push-button 27, is attached to the wire *l*, which connects with the lead wire *b* and also with the ground wire *k*, as at *o*, and has the condenser *m* and bells *n* in series therein, thus forming a ringing circuit which may be thrown in series with the talking circuit to allow the voice currents to pass to the condenser *m* by moving the push-button 27 to close the contact 28—30. The secondary circuit of the telephone comprises the usual receiver 3, wires *P* and the secondary of the induction coil *g*.

The operation of our invention is as follows:—Party "A", wishing to call party "B", takes his receiver from the hook and asks central for such party in the usual manner. As the outer end of the receiver-hook raises on being relieved of the weight of the receiver, the primary circuit between the wire *i* and lead wire *b* is closed in the usual manner, and the armature 7 is permitted to drop by gravity from contact with the dead magnet 5 due to the lowering of the spring-finger 9, the contact between the receiver hook and lead *b* taking place before the contact 15—15' can be broken. As the armature lowers the pin 12 is drawn down therewith and effects or permits a movement of the spring 15 to break contact with its companion, and a movement of the spring 14 to make contact with its companion, thus closing the primary circuit and opening the grounding circuit of such telephone. Should any other party now take his receiver from its hook his telephone is instantly and automatically grounded due to a current flowing from battery *e* through *a* at station A, 14, 14', 28, 29, *i*, 2 and *b* to main *d* and back from the main line wire *d*, through his lead wire *l*, receiver-hook 2, wire *i*, coil *g*, wire *j*, contacts 15, 15' to the ground wire *k*, as shown in diagram B. The energizing of the magnet 5 by the current passing through its coil holds the armature 7 to it and holds the pin 12 elevated so that contact is maintained between the grounding springs 15, 15' and broken between the main circuit contacts 14, 14'. In order to allow the party

called to come in on the line, "A", as soon as he has given his directions to central, presses the push-button 27, thus throwing the spring 28 into contact with the contact-piece 30 and releasing the dry or negative 70 side of the battery from the line so that the other parties on the line are released from the ground and the armature of any one of them free to drop when the associated receiver is taken from its hook, as above described for "A" when he came in on the 75 line. The button 27 is maintained in pushed position until the party called comes in on the line, which the party calling is able to tell by reason of the voice currents passing 80 through the condenser *m* of his telephone, after which he releases the button, so that the two can talk while all others are effectually locked out. Should "A" desire to call 85 a party on any other line the action would be the same, except that he would not have to push the button to let the party in. As soon as party called takes down his receiver, all other parties on line are locked out, as 90 above described.

It is apparent that our lock-out apparatus is exceedingly simple in its construction, operation, and instalment, thus enhancing its practicability and commercial value; that it does not necessitate the use of an additional condenser in the telephone instrument, 95 as is necessary with other apparatus of this nature, and that it needs no adjustment after being placed in the instrument.

We wish it understood that we do not desire to be restricted to the exact details of construction and arrangement of the parts shown and described, as obvious modifications will occur to persons skilled in the art. 100

Having thus described our invention, what we claim as new and desire to secure by Letters Patent, is,— 105

1. In a party-line telephone, a primary circuit having make and break contacts therein, a ground circuit having make and break contacts therein, means movable to make contact between one set of contacts and break contact between the other set of contacts, or vice versa, a receiver-hook cooperating with said means to hold the primary circuit contacts open and the ground circuit contacts closed when the outer end of the hook is lowered, said means being free to move to release the ground when no other telephone in the line is in use and magnetically controlled to maintain a position which closes the ground circuit and opens the primary circuit when another telephone in the line is in use. 110 115 120

2. In a party-line telephone, a primary circuit provided with make and break contact parts, a ground circuit provided with make and break contact parts, an electro-magnet disposed in said ground circuit, an armature associated with the electro-magnet 125 130

and insulatingly coacting with the primary and ground circuit contact parts to adapt it when moved to break contact between one set and make contact between the other set or vice versa, a receiver-hook having an inner end part which when elevated coacts with the armature to hold it in closed position with its magnet with the primary circuit contacts broken and the ground circuit contacts made, said armature being magnetically influenced to maintain such closed position when another telephone in the line is in use.

3. In a party-line telephone, a primary circuit provided with make and break contact parts, a ground circuit leading therefrom and provided with make and break contact parts, mechanically and magnetically controlled means adapted when in one position of its movement to make contact between one set and break contact between the other set of said parts and vice versa when in its other position of movement, said means being magnetically free to move to release the ground and close the primary circuit contact parts when no other telephone in the line is in use and magnetically controlled to maintain a position which closes the ground circuit and opens the primary circuit when another telephone in the line is in use.

4. In a party-line telephone, a primary circuit and a ground circuit each having make and break contact parts, a member movable to open one circuit and close the other and vice versa, and mechanical means and magnetic means adapted to act on said member to hold it in position to close the ground circuit and open the primary circuit, said magnetic means being energized when another telephone in the line is in use.

5. In a party-line telephone, a primary and a ground circuit each having make and break contact parts, an electro-magnet in series with the ground circuit, an armature associated with the magnet and adapted when in closed contact therewith to maintain the primary contacts in open and the ground contacts in closed position, a receiver-hook having part coacting with the armature to hold it in closed contact with the magnet when the outer end of the hook is lowered, said armature being free to move by gravity out of closed contact with the magnet when the outer end of the hook is raised and no other telephone in the line is in use and magnetically influenced to maintain such contact when another telephone in the line is in use.

6. In a party-line telephone, a primary and a ground circuit each having make and break contact parts, a member movable to open one circuit and close the other and vice versa, mechanical means and magnetic means adapted to act on said member to hold it in

position to close the ground circuit and open the primary circuit, said magnetic means being energized when another telephone in the line is in use, and means for releasing the ground from the telephone being called. 70

7. In a party-line telephone, a primary and a ground circuit each having make and break contact parts, a member movable to open one circuit and close the other and vice versa, means acting on said member when the telephone is not in use whereby to close the ground circuit and open the primary circuit, magnetic means acting on said member to maintain it in such closed ground and open primary circuit position when another telephone in the line is in use, and manually controlled means for releasing the ground from the telephone of the party called. 80

8. In a party line telephone, a primary and a ground circuit each having make and break contact parts, an electro-magnet in series with the ground circuit, an armature adapted to form a closed magnetic circuit with the magnet and having parts which cooperate with said contacts to maintain the ground circuit closed and the primary circuit open when the armature is in closed position and vice versa when the armature is in open position, said electro-magnet being energized when any other telephone in the line is in use, means which automatically acts on the armature to maintain it in closed position when its telephone is not in use, and means for releasing the ground from any other telephone in the line. 100

9. In a party-line telephone, a talking and a ground circuit each having make and break contact parts, a member movable to open one circuit and close the other and vice versa, mechanical means and magnetic means adapted to act on said member to hold it in position to close the ground circuit and open the talking circuit, said magnetic means being energized when any other telephone in the line is in use, a bell-circuit having a condenser in series therein, and means movable to effect a release of the ground from all other telephones in the line and to throw the ringing circuit in series with a portion of the talking circuit to allow the voice currents to pass to the condenser. 115

10. In a party-line telephone, a primary and a ground circuit each having make and break contact parts, an armature movable to open one circuit and close the other and vice versa, mechanical and magnetic means adapted to act on the armature to hold it in position to open the primary circuit and close the ground circuit, said mechanical means acting in such manner when the telephone is not in use, and said magnetic means being energized when any other telephone in the line is in use, a ringing circuit, call-bells and a condenser in series in the ringing circuit, and a switch adapted to 130

make contact between two parts of the primary circuit or to be moved to cut in the ringing circuit, the ground being released from all other telephones on the line when the switch is moved to cut in the ringing circuit.

11. In a central energy telephone plant, a plurality of telephones bridged across the main, each phone having a primary and a ground circuit, make and break contact parts in each circuit, an armature cooperating with said contact parts and movable to open the primary contacts and close the ground contacts and vice versa, a receiver-hook adapted, when its outer end is down, to hold the armature in position to close the ground contacts and open the primary contacts, an electro-magnet disposed in the ground circuit and adapted, when energized, to hold the armature in position to close the ground contacts and open the primary contacts, said magnet being energized when any other telephone in the line is in use and said armature being free to drop by gravity to open the ground circuit and close the primary circuit when the outer end of the associated receiver-hook raises and no other telephone in the line is in use, and means operated by party calling for reliev-

ing the ground from every other telephone in the line.

12. In a party-line telephone, a primary circuit and a ground circuit each having make and break contact parts, a member movable to open one circuit and close the other and vice versa, mechanical means and magnetic means adapted to act independently on said member to hold it in position to close the ground circuit and open the primary circuit, said mechanical means being automatically released from said member when the telephone receiver is taken from its hook and said magnetic means being energized when another telephone in the line is in use, and manually controlled means for releasing the ground from the telephone of a party called and enabling the party calling to tell when a party comes in on the line.

In testimony whereof we have hereunto signed our names to this specification in the presence of two subscribing witnesses.

WILLIAM F. WAGNER.  
WILLIAM E. SHIELS.

Witnesses:

CORNELL SCHREIBER,  
WILBER A. OWEN.