



EUROPEAN PATENT APPLICATION

Application number : **94301261.7**

Int. Cl.⁵ : **G08G 5/06**

Date of filing : **23.02.94**

Priority : **26.02.93 US 23978**

Inventor : **Hoover, Peter L.**
20 Kelleher Street
Marlboro, MA 01752 (US)

Date of publication of application :
31.08.94 Bulletin 94/35

Representative : **Jackson, David Spence et al**
REDDIE & GROSE
16, Theobalds Road
London, WC1X 8PL (GB)

Designated Contracting States :
DE ES FR GB IT NL SE

Applicant : **RAYTHEON COMPANY**
141 Spring Street
Lexington Massachusetts 02173 (US)

Infrared vehicle identification system.

An infrared vehicle identification system [109] comprising a microprocessor controlled infrared (IR) transmitter [112] located on an aircraft nose wheel landing strut [111] and an infrared receiver [128] including a microprocessor [44] enclosed in a plurality of edge light assemblies [20] located along surface pathways of an airport including runways and taxiways. The infrared transmitter [112] comprises an array of light emitting diodes [120] (LEDs) arranged in a semicircle within the horizontal plane. The transmitter [112] emits a plurality of fields [121, Fig.13] of encoded data to provide vehicle identification and position information. One field [122] comprises a steady stream of pulses that allows the IR receiver [128] to calculate the baud rate of the transmitter [112] and automatically adjust its internal timing. The other fields include a unique word [123] for marking the beginning of a message, the number [124] of characters in the message, the vehicle identification number [125], the vehicle position [126] and a checksum [127]. The latter [127] ensures that a complete and correct message has been received. If the transmitted message is interrupted for any reason, the checksum [127] will detect it and the messages will be voided. The IR receiver [128] relays a valid message of vehicle identification [125] and position [126] to a central computer system [12, Fig.1] at the airport control tower via the edge light assembly power wiring [21, Fig.1].

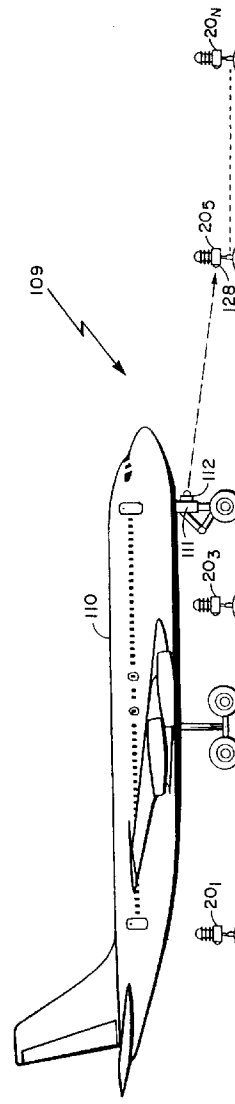

FIG. 10

Background of the Invention

This invention relates to identification of airport surface traffic and in particular to an apparatus and method for detecting and identifying aircraft or other vehicle movement on airport taxiways, runways and other surface areas.

Currently, ground control of aircraft at an airport is done visually by the air traffic controller in the tower. Low visibility conditions sometimes make it impossible for the controller to see all parts of the field. Ground surface radar can help in providing coverage during low visibility conditions; it plays an important part in the solution of the runway incursion problem but cannot solve the entire problem. A runway incursion is defined as "any occurrence at an airport involving an aircraft, vehicle, person, or object on the ground that creates a collision hazard or results in loss of separation with an aircraft taking off, intending to take off, landing, or intending to land." The U.S. Federal Administration Agency (FAA) has estimated that it can only justify the cost of ground surface radar at 29 of the top 100 airports in the United States. However, such radar only provides location information; it cannot alert the controller to possible conflicts between aircraft.

In the prior art, an airport control and monitoring system has been used to sense when an airplane reaches a certain point on a taxiway and controls switching lights on and off to indicate to the pilot when he may proceed on to a runway. Such a system sends microwave sensor information to a computer in the control tower. The computer comprises software for controlling the airport lighting and for providing fault information on the airport lighting via displays or a control panel to an operator. Such a system is described in sales information provided on a Bi-directional Series 7 Transceiver (BRITEE) produced by ADB-ALNACO, Inc., A Siemens Company, of Columbus, Ohio. However, such a system does not show the location of all vehicles on an airfield and is not able to detect and avoid a possible vehicle incursion.

A well known approach to airport surface traffic control has been the use of scanning radars operating at high frequencies such as K-band in order to obtain adequate definition and resolution. An existing airport ground traffic control equipment of that type is known in the art as Airport Surface Detection Equipment (ASDE). However, such equipment provides surveillance only, no discrete identification of aircraft on the surface being available. Also there is a need for a relatively high antenna tower and a relatively large rotation antenna system thereon.

Another approach to airport ground surveillance is a system described in U. S. Patent No. 3,872,474, issued March 18, 1974, to Arnold M. Levine and assigned to International Telephone and Telegraph Corporation, New York, NY, referred to as LOCAR (Localized Cable Radar) which comprises a series of small, lower powered, narrow pulses, transmitting radars having limited range and time sequenced along opposite sides of a runway ramp or taxiway. In another U. S. Patent No. 4,197,536, issued on April 8, 1980, to Arnold M. Levine, an airport surface identification and control system is described for aircraft equipped with ATCRBS (Air Traffic Control Radio Beacon System) and ILS (Instrument Landing System). However, these approaches are expensive, require special cabling and for identification purposes require expensive equipment to be included on the aircraft and other vehicles.

Another approach to vehicle identification such as types of aircraft by identifying the unique characteristic of the "footprint" presented by the configuration of wheels unique to a particular type of vehicle is described in U.S. Patent No. 3,872,283, issued March 18, 1975, to Gerald R. Smith et al. and assigned to The Cadre Corporation of Atlanta Georgia.

An automatic system for surveillance, guidance and fire-fighting at airports using infrared sensors is described in U. S. Patent No. 4,845,629, issued July 4, 1989 to Maria V. Z. Murga. The infrared sensors are arranged along the flight lanes and their output signals are processed by a computer to provide information concerning the aircraft movements along the flight lanes. Position detectors are provided for detecting the position of aircraft in the taxiways and parking areas. However, such system does not teach the use of edge lights along the runways and taxiways along with their associated wiring and it is not able to detect and avoid a possible vehicle incursion.

The manner in which the invention deals with the disadvantages of the prior art to provide a low cost infrared vehicle identification system will be evident as the description proceeds.

Summary of the Invention

Accordingly, it is therefore an object of this invention to provide a low cost infrared system that identifies aircraft or other vehicles on airport taxiways and runways.

It is also an object of this invention to provide at an airport a low cost aircraft or vehicle identification system using existing edge light assemblies and associated wiring along runways and taxiways.

It is another object of this invention to provide an infrared vehicle identification system that generates a

graphic display of the airport showing the location of all ground traffic including direction and velocity data and identifies such ground traffic.

5 The objects are further accomplished by providing a vehicle identification system for identifying aircraft and other vehicles on surface pathways including runways and other areas of an airport comprising means disposed on the aircraft and other vehicles for transmitting identification message data, means disposed in each of a plurality of light assembly means on the airport for receiving and decoding the message data from the transmitting means, means for providing power to each of the plurality of light assembly means, means for processing the decoded identification message data generated by the receiving and decoding means in each of the plurality of light assembly means, means for providing data communication between each of the 10 light assembly means and the processing means, and the processing means comprises means for providing a graphic display of the airport comprising symbols representing the aircraft and other vehicles, each of the symbols having the identification message data displayed. The transmitting means comprises means for creating unique message data which includes aircraft and flight identification, and infrared means coupled to the message creating means for transmitting a coded stream of the message data. The message data further includes 15 position information. The receiving and decoding means comprises an infrared sensor. The receiving and decoding means comprises microprocessor means coupled to the infrared sensor for decoding the message data. The plurality of light assembly means are arranged in two parallel rows along runways and taxiways of the airport. The light assembly means comprises light means coupled to the lines of the power providing means for lighting the airport, vehicle sensing means for detecting aircraft or other vehicles on the airport, microprocessor means coupled to the receiving and decoding means, the light means, the vehicle sensing means and the data communication means for decoding the identification message data, and the data communication means being coupled to the microprocessor means and the lines of the power providing means. The symbols representing aircraft and other vehicles comprise icons having a shape indicating type of aircraft or vehicle. The processing means determines a location of the symbols on the graphic display of the airport in accordance with data received from the light assembly means. 25

The objects are further accomplished by a vehicle identification system for surveillance and identification of aircraft and other vehicles on an airport comprising a plurality of light circuits on the airport, each of the light circuits comprises a plurality of light assembly means, means for providing power to each of the plurality of light circuits and to each of the light assembly means, means in each of the light assembly means for sensing 30 ground traffic on the airport, means disposed on the aircraft and other vehicles for transmitting identification message data, means disposed in each of the light assembly means for receiving and decoding the message data from the transmitting means, means for processing ground traffic data from the sensing means and decoded message data from each of the light assembly means for presentation on a graphic display of the airport, means for providing data communication between each of the light assembly means and the processing means, 35 the processing means comprises means for providing such graphic display of the airport comprising symbols representing the ground traffic, each of the symbols having direction, velocity and the identification message data displayed. Each of the light circuits are located along the edges of taxiways or runways on the airport. The sensing means comprises infrared detectors. The transmitting means comprises means for creating unique message data which includes aircraft and flight identification, and infrared means coupled to the message creating means for transmitting a coded stream of the message data. The message data further comprises 40 position information. The receiving and decoding means comprises an infrared sensor. The receiving and decoding means comprises microprocessor means coupled to the infrared sensor for decoding the message data. The plurality of light assembly means of the light circuits being arranged in two parallel rows along runways and taxiways of the airport. The light assembly means comprises light means coupled to the lines of the power providing means for lighting the airport, the ground traffic sensing means for detecting aircraft or other vehicles on the airport, microprocessor means coupled to the receiving and decoding means, the light means, the ground traffic sensing means and the data communication means for decoding the identification message data and processing a detection signal from the ground traffic sensing means, and the data communication means being coupled to the microprocessor means and the lines of the power providing means. 45 The light assembly means further comprises a photocell means coupled to the microprocessor means for detecting the light intensity of the light means. The light assembly means further comprises a strobe light coupled to the microprocessor means. The processing means comprises redundant computers for fault tolerance operation. The symbols representing the ground traffic comprise icons having a shape indicating type of aircraft or vehicle. The processing means determines a location of the symbols on the graphic display of the airport in accordance with the data receive from the light assembly means. The processing means determines a future 50 path of the ground traffic based on a ground clearance command, the future path being shown on the graphic display. The processing means further comprises means for predicting an airport incursion. The power providing means comprises constant current power means for providing a separate line to each of the plurality of 55

light circuits, and network bridge means coupled to the constant current power means for providing a communication channel to the processing means for each line of the constant current power means.

The objects are further accomplished by providing a method of providing a vehicle identification system for identifying aircraft and other vehicles on surface pathways including runways and other areas of an airport comprising the steps of transmitting identification message data with means disposed on the aircraft and other vehicles, receiving and decoding the message data from the transmitting means with means disposed in each of a plurality of light assembly means on the airport, providing power to each of the plurality of light assembly means, processing the decoded identification message data generated by the receiving and decoding means in each of the plurality of light assembly means, providing data communication between each of the light assembly means and the processing means, and providing a graphic display of the airport with the processing means comprising symbols representing the aircraft and other vehicles, each of the symbols having the identification message data displayed. The step of transmitting identification message data comprises the steps of creating unique message data which includes aircraft and flight identification, and transmitting a coded stream of the message data with infrared means coupled to the message creating means. The step of transmitting message data further includes transmitting position information. The step of receiving and decoding the message data includes using an infrared sensor. The step of receiving and decoding the message data further comprises the step of coupling microprocessor means to the infrared sensor for decoding the message data. The step of receiving and decoding the message data with means disposed in the plurality of light assembly means further comprises the step of arranging the plurality of light assembly means in two parallel rows along runways and taxiways of the airport. The step of providing a graphic display comprising symbols representing aircraft and other vehicles further comprises the step of providing icons having a shape indicating type of aircraft or vehicle. The step of providing a graphic display comprises the step of determining a location of the symbols on the graphic display of the airport in accordance with data received from the light assembly means.

Brief Description of the Drawings

Other and further features of the invention will become apparent in connection with the accompanying drawings wherein:

FIG. 1 is a block diagram of an airport vehicle incursion avoidance system;
 FIG. 2 is a block diagram of an edge light assembly showing a sensor electronics unit coupled to an edge light of an airfield lighting system;
 FIG. 3 is a pictorial diagram of the edge light assembly showing the edge light positioned above the sensor electronics unit;
 FIG. 4 is a diagram of an airfield runway or taxiway having a plurality of edge light assemblies positioned along each side of the runway or taxiway for detecting various size aircraft as shown;
 FIG. 5 is a block diagram of the central computer system shown in FIG. 1;
 FIG. 6 shows eleven network variables used in programming the microprocessor of an edge light assembly to interface with a sensor, a light and a strobe light;
 FIG. 7 is a block diagram showing an interconnection of network variables for a plurality of edge light assemblies located on both sides of a runway, each comprising a sensor electronics unit 10 positioned along a taxiway or runway;
 FIG. 8 shows a graphic display of a typical taxiway/runway on a portion of an airport as seen by an operator in a control tower, the display showing the location of vehicles as they are detected by the sensors mounted in the edge light assemblies located along taxiways and runways;
 FIG. 9 is a block diagram of the data flow within the system shown in FIG. 1 and FIG. 5;
 FIG. 10 is a pictorial diagram of an infrared identification system showing an IR transmitter mounted on an airplane wheel strut and an IR receiver mounted in an edge light assembly of an airport lighting system;
 FIG. 11 is a block diagram of an IR transmitter of an IR vehicle identification system;
 FIG. 12 shows a top view of the IR transmitter mounted on an airplane wheel strut providing a 195° area of coverage generated by an IR light emitting diode array in the IR transmitter;
 FIG. 13 shows data fields of a coded data stream transmitted by the IR transmitter;
 FIG. 14 is a block diagram of an IR receiver of the IR vehicle identification system;
 FIG. 15 is a flow chart of an IR message routine which is a communication protocol continuously performed in an IR receiver microprocessor; and
 FIG. 16 is a flow chart of a vehicle sensor routine which is continuously performed in an IR receiver microprocessor.

Description of the Preferred Embodiment

Referring to FIG. 1 a block diagram of an airport vehicle incursion avoidance system 10 is shown comprising a plurality of light circuits 18_{1-n}, each of said light circuits 18_{1-n} comprises a plurality of edge light assemblies 20_{1-n} connected via wiring 21_{1-n} to a lighting vault 16 which is connected to a central computer system 12 via a wide area network 14. Each of the edge light assemblies 20_{1-n} comprises an infrared (IR) detector vehicle sensor 50 (FIG. 2).

The edge light assemblies 20_{1-n} are generally located along side the runways and taxiways of the airport with an average 100 foot spacing and are interconnected to the lighting vault 16 by single conductor series edge light wiring 21_{1-n}. Each of the edge light circuits 18_{1-n} is powered via the wiring 21_{1-n} by a constant current supply 24_{1-n} located in the lighting vault 16.

Referring now to FIG. 1 and FIG. 2, communication between the edge light assemblies 20_{1-n} and the central computer system 12 is accomplished with LON Bridges 22_{1-n} interconnecting the edge light wiring 21_{1-n} with the Wide Area Network 14. Information from a microprocessor 44 located in each edge light assembly 20_{1-n} is coupled to the edge light wiring 21_{1-n} via a power line modem 54. The LON bridges 22_{1-n} transfers message information from the edge light circuits 18_{1-n} via the wiring 21_{1-n} to the wide area network 14. The wide area network 14 provides a transmission path to the central computer system 12. These circuit components also provide the return path communications link from the central computer system 12 to the microprocessor 44 in each edge light assembly 20_{1-n}. Other apparatus and methods, known to one of ordinary skill in the art, for data communication between the edge light assemblies 20_{1-n} and the central computer system 12 may be employed, such as radio techniques, but the present embodiment of providing data communication on the edge light wiring 21_{1-n} provides a low cost system for present airports. The LON Bridge 22 may be embodied by devices manufactured by Echelon Corporation of Palo Alto, California. The wide area network 14 may be implemented by one of ordinary skill in the art using standard Ethernet or Fiber Distributed Data Interface (FDDI) components. The constant current supply 24 may be embodied by devices manufactured by Crouse-Hinds of Winslow, Connecticut.

Referring now to FIG. 2 and FIG. 3, FIG. 3 shows a pictorial diagram of the edge light assembly 20_{1-n}. The edge light assembly 20_{1-n} comprises a bezel including an incandescent lamp 40 and an optional strobe light assembly 48 (FIG. 2) which are mounted above an electronics enclosure 43 comprising a vehicle sensor 50. The electronics enclosure 43 sits on the top of a tubular shaft extending from a base support 56. The light assembly bezel with lamp 40 and base support 56 may be embodied by devices manufactured by Crouse-Hinds of Winslow, Connecticut.

A block diagram of the contents of the electronics enclosure 43 is shown in FIG. 2 which comprises a coupling transformer 53 connected to the edge light wiring 21_{1-n}. The coupling transformer 53 provides power to both the incandescent lamp 40 via the lamp control triac 42 and the microprocessor power supply 52; in addition, the coupling transformer 53 provides a data communication path between the power line modem 54 and the LON Bridges 22_{1-n} via the edge light wiring 21_{1-n}. The microprocessor 44 provides the computational power to run the internal software program that controls the edge light assemblies 20_{1-n}. The microprocessor 44 is powered by the microprocessor power supply 52. Also connected to the microprocessor 44 is the lamp control triac 42, a lamp monitoring photo cell 46, the optional strobe light assembly 48, the vehicle sensor 50, and the data communications modem 54. The microprocessor 44 is used to control the incandescent edge light 40 intensity and optional strobe light assembly 48. The use of the microprocessor 44 in each light assembly 20_{1-n} allows complete addressable control over every light on the field. The microprocessor 44 may be embodied by a VLSI device manufactured by Echelon Corporation of Palo Alto, California 94304, called the Neuron[®] chip.

Still referring to FIG. 2, the sensor 50 in the present embodiment comprises an infrared (IR) detector and in other embodiments may comprise other devices such as proximity detectors, CCD cameras, microwave motion detectors, inductance loops, or laser beams. The program in the microprocessor 44 is responsible for the initial filtering of the sensor data received from the sensor 50 and responsible for the transmission of such data to the central computer system 12. The sensor 50 must perform the following functions: detect a stationary object, detect a moving object, have a range at least half the width of the runway or taxiway, be low power and be immune to false alarms. This system design does not rely on just one type of sensor. Since sensor fusion functions are performed within the central computer system 12, data inputs from all different types of sensors are acceptable. Each sensor relays a different view of what is happening on the airfield and the central computer system 12 combines them. There are a wide range of sensors that may be used in this system. As a new sensor type becomes available, it can be integrated into this system with a minimum of difficulty. The initial sensor used is an IR proximity detector based around a piezoelectric strip. These are the kind of sensors you use at home to turn on your flood lights when heat and/or movement is detected. When the sensor output pro-

vides an analog signal, an analog-to-digital converter readily known in the art may be used to interface with the microprocessor 44.

Another proximity detector that can be used is based around a microwave Gunn diode oscillator. These are currently in use in such applications as Intrusion Alarms, Door Openers, Distance Measurement, Collision
 5 Warning, Railroad Switching, etc. These types of sensors have a drawback because they are not passive devices and care needs to be taken to select frequencies that would not interfere with other airport equipment. Finally, in locations such as the hold position lines on taxiways, solid state laser and detector combinations could be used between adjacent taxiway lights. These sensor systems create a beam that when broken would identify the location of the front wheel of the airplane. This type of detector would be used in those locations
 10 where the absolute position of a vehicle was needed. The laser beam would be modulated by the microprocessor 44 to avoid the detector being fooled by any other stray radiation.

Referring to FIG. 2 and FIG. 4, a portion of an airport runway 64 or taxiway is shown having a plurality of edge light assemblies 20_{1-8} positioned along each side of the runway or taxiway for detecting various size airplanes or vehicles 60, 62. The dashed lines represent the coverage area of the sensors 50 located in each
 15 edge light assembly 20_{1-8} positioned along each side of the runway 64 or taxiway to insure detection of any airplane 60, 62 or other vehicles traveling on such runway 64 or taxiway. The edge light assemblies 20_{1-n} comprising the sensor 50 are logically connected together in such a way that an entire airport is sensitized to the movement of vehicles. Node to node communication takes place to verify and identify the location of the vehicles. Once this is done a message is sent to the central computer system 12 reporting the vehicles location.
 20 Edge lights assemblies (without a sensor electronics unit 43) and taxiway power wiring currently exist along taxiways, runways and open areas of airports, therefore, the sensor electronics unit 43 is readily added to existing edge lights and existing taxiway power wiring without the inconvenience and expense of closing down runways and taxiways while installing new cabling.

Referring now to FIG. 1, FIG. 5, FIG. 8 and FIG. 9, the central computer system 12 is generally located at
 25 a control tower or terminal area of an airport and is interconnected to the LON Bridges 22_{1-n} located in the lighting vault 16 with a Wide Area Network 14. The central computer system 12 comprises two redundant computers, computer #1 26 and computer #2 28 for fault tolerance, the display 30, speech synthesis units 29 & 31, alert lights 34, keyboard 27 and a speech recognition unit 33, all of these elements being interconnected by the wide area network 14 for the transfer of information. The two computers 26 and 28 communicate with
 30 the microprocessors 44 located in the edge light assemblies 20_{1-n} . Data received from the edge light assembly 20_{1-n} microprocessors 44 are used as an input to a sensor fusion software module 101 (FIG. 9) run on the redundant computers 26 and 28. The output of the sensor fusion software module 101 operating in the computers 26, 28 is used to drive the CRT display 30 which displays the location of each vehicle on the airport taxiway and runways as shown in FIG. 8. The central computer system 12 may be embodied by devices manufactured by IBM Corporation of White Plains, New York. The Wide Area Network 14 may be embodied by
 35 devices manufactured by 3Com Corporation of Santa Clara, California. The speech synthesis units 29, 31 and the speech recognition unit 33 may be embodied by devices manufactured by BBN of Cambridge, Massachusetts.

The speech synthesis unit 29 is coupled to a speaker 32. Limited information is sent to the speech synthesis
 40 unit 29 via the wide area network 14 to provide the capability to give an air traffic controller a verbal alert. The speech synthesis unit 31 is coupled to a radio 37 having an antenna 39 to provide the capability to give the pilots a verbal alert. The voice commands from the air traffic controller to the pilots are captured by microphone 35 and sent to the pilots via radio 36 and antenna 38. In the present embodiment a tap is made and the speech information is sent to both the radio 36 and the speech recognition unit 33 which is programmed to recognize
 45 the limited air traffic control vocabulary used by a controller. This includes airline names, aircraft type, the numbers 0-9, the name of the taxiways and runways and various short phrases such as "hold short", "expedite" and "give way to." The output of the speech recognition unit 33 is fed to the computers 26, 28.

Referring again to FIG. 2, the power line modem 54 provides a data communication path over the edge
 50 light wiring 21_{1-n} for the microprocessor 44. This two way path is used for the passing of command and control information between the various edge light assemblies 20_{1-n} and the central computer system 12. A power line transceiver module in the power line modem 54 is used to provide a data channel. These modules use carrier current approach to create the data channel. Power line modems that operate at carrier frequencies in the 100 to 450 KHz band are available from many manufacturers. These modems provide digital communication paths at data rates of up to 10,000 bits per second utilizing direct sequence spread spectrum modulation. They conform to FCC power line carrier requirements for conducted emissions, and can work with up to 55 dB of power
 55 line attenuation. The power line modem 54 may be embodied by a device manufactured by Echelon Corporation of Palo Alto, California 94304, called the PLT-10 Power Line Transceiver Module.

The data channel provides a transport layer or lowest layer of the open system interconnection (OSI) protocol used in the data network. The Neuron[®] chip which implements the microprocessor 44 contains all of the firmware required to implement a 7 layer OSI protocol. When interconnected via an appropriate medium the Neuron[®] chips automatically communicate with one another using a robust Collision Sense Multiple Access (CSMA) protocol with forward error corrections, error checking and automatic retransmission of missed messages (ARQ).

The command and control information is placed in data packets and sent over the network in accordance with the 7 Layer OSI protocol. All messages generated by the microprocessor 44 and destined for the central computer system 12 are received by the network bridge 22 via the power lines 21_{1-n} and routed to the central computer system 12 over the wide area network 14.

The Neuron[®] chip of the microprocessor 44 comprises three processors (not shown) and the firmware required to support a full 6 layer open systems interconnection (OSI) protocol. The user is allocated one of the processors for the application code. The other two processors give the application program access to all of the other Neuron[®] chips in the network. This access creates a Local Operating Network or LON. A LON can be thought of as a high level local area network LAN. The use of the Neuron[®] chip for the implementation of this invention, reduces the amount of custom hardware and software that otherwise would have to be developed.

Data from the sensor electronic unit 43 of the edge light assemblies 20_{1-n} is coupled to the central computer system 12 via the existing airport taxiway lighting power wiring 21. Using the existing edge light power line to transfer the sensor data into a LON network has many advantages. As previously pointed out, the reuse of the existing edge lights eliminates the inconvenience and expense of closing down runways and taxiways while running new cable and provides for a low cost system.

The Neuron[®] chip allows the edge light assemblies 20_{1-n} to automatically communicate with each other at the applications level. This is accomplished through network variables which allow individual Neuron[®] chips to pass data between themselves. Each Neuron[®] 'C' program comprises both local and network variables. The local variables are used by the Neuron[®] program as a scratch pad memory. The network variables are used by the Neuron[®] program in one of two ways, either as a network output variables or a network input variables. Both kinds of variables can be initialized, evaluated and modified locally. The difference comes into play in that once a network output variable is modified, network messages are automatically sent to each network input variable that is linked to that output variable. This variable linking is done at installation time. As soon as a new value of a network input variable is received by a Neuron[®] chip, the code is vectored off to take appropriate action based upon the value of the network input variable. The advantage to the program is that this message passing scheme is entirely transparent since the message passing code is part of the embedded Neuron[®] operating system.

Referring now to FIG. 6, eleven network variables have been identified for a sensor program in each microprocessor 44 of the edge light assemblies 20_{1-n}. The sensor 50 function has two output variables: prelim_detect 70 and confirmed_detect 72. The idea here is to have one output trigger whenever the sensor 50 detects movement. The other output does not trigger unless the local sensor and the sensor on the edge light across the runway both spot movement. Only when the detection is confirmed will the signal be fed back to the central computer system 12. This technique of confirmation helps to reduce false alarms in order to implement this technique the adjacent sensor 50 has an input variable called adj_prelim_detect 78 that is used to receive the other sensors prelim_detect output 70. Other input variables are upstream_detect 74 and downstream_detect 76 which are used when chaining adjacent sensors together. Also needed is a detector_sensitivity 80 input that is used by the central computer system 12 to control the detection ability of the sensor 50.

The incandescent light 40 requires two network variables, one input and the other an output variable. The input variable light_level 84 would be used to control the light's brightness. The range would be OFF or 0% all the way to FULL ON or 100%. This range from 0% to 100% would be made in 0.5% steps. Since the edge light assembly 20_{1-n} also contains the photocell 46, an output variable light_failure 84 is created to signal that the lamp did not obtain the desired brightness.

The strobe light 48 requires three input variables. The strobe-mode 86 variable is used to select either the OFF, SEQUENTIAL, or ALTERNATE flash modes. Since the two flash modes require a distinct pattern to be created, two input variables active_delay 88 and flash_delay 90 are used to time align the strobe flashes. By setting these individual delay factors and then addressing the Neuron[®] chips as a group, allows the creation of a field strobe pattern with just one command.

Referring now to FIG. 7, a block diagram of an interconnection of network variables for a plurality of edge light assemblies 20_{1-n} located on both sides of a runway is shown, each of the edge light assemblies 20_{1-n} comprising a microprocessor 44. Each Neuron[®] program in the microprocessor 44 is designed with certain network input and output variables. The user writes the code for the Neuron[®] chips in the microprocessor 44

assuming that the inputs are supplied and that the outputs are used. To create an actual network the user has to "wire up" the network by interconnecting the individual nodes with a software linker. The resulting distributed process is best shown in schematic form, and a portion of the network interconnect matrix is shown in Figure 7. The `prelim_detect 70` output of a sensor node `441` is connected to the `adj_primary_detect 92` input of the sensor node `444` across the taxiway. This is used as a means to verify actual detections and eliminate false reports. The communications link between these two nodes `441` and `444` is part of the distributed processing. The two nodes communicate among themselves without involving the central computer system 12. If in the automatic mode or if instructed by the controller, the system will also alert the pilots via audio and visual indications.

Referring again to FIG. 1 and FIG. 4, the central computer system 12 tracks the movement of vehicles as they pass from the sensor 50 to sensor 50 in each edge light assembly `201-n`. Using a variation of a radar automatic track algorithm, the system can track position, velocity and heading of all aircraft or vehicles based upon the sensor 50 readings. New vehicles are entered into the system either upon leaving a boarding gate or landing. Unknown vehicles are also tracked automatically. Since taxiway and runway lights are normally across from each other on the pavement (as shown in FIG. 4 and FIG. 7), the microprocessor 44 in each edge lights assembly `201-n` is programmed to combine their sensor 50 inputs and agree before reporting a contact. A further refinement is to have the microprocessor 44 check with the edge light assemblies `201-n` on either side of them to see if their sensors 50 had detected the vehicle. This allows a vehicle to be handed off from sensor electronic unit 43 to sensor electronic unit 43 of each edge light assembly `201-n` as it travels down the taxiway. This also assures that vehicle position reports remain consistent. Vehicle velocity may also be calculated by using the distance between sensors, the sensor pattern and the time between detections.

Referring to FIG. 5 and FIG. 8, the display 30 is a color monitor which provides a graphical display of the airport, a portion of which is shown in FIG. 8. This is accomplished by storing a map of the airport in the redundant computers 26 and 28 in a digital format. The display 30 shows the location of airplanes or vehicles as they are detected by the sensors 50 mounted in the edge light assemblies `201-n` along each taxiway and runway or other airport surface areas. All aircraft or vehicles on the airport surface are displayed as icons, with the shape of the icons being determined by the vehicle type. Vehicle position is shown by the location of the icon on the screen. Vehicle direction is shown by either the orientation of the icon or by an arrow emanating from the icon. Vehicle status is conveyed by the color of the icon. The future path of the vehicle as provided by the ground clearance command entered via the controllers microphone 35 is shown as a colored line on the display 30. The status of all field lights including each edge light `201-n` in each edge light circuit `181-n` is shown via color on the display 30.

Use of object orientated software provides the basis for building a model of an airport. The automatic inheritance feature allows a data structure to be defined once for each object and then replicated automatically for each instance of that object. Automatic flow down assures that elements of the data base are not corrupted due to typing errors. It also assures that the code is regular and structured. Rule based object oriented programming makes it difficult to create unintelligible "spaghetti code." Object oriented programming allows the runways, taxiways, aircraft and sensors, to be decoded directly as objects. Each of these objects contains attributes. Some of these attributes are fixed like runway 22R or flight UA347, and some are variable like vehicle status and position.

In conventional programming we describe the attributes of an object in data structures and then describe the behaviors of the object as procedures that operate on those data structures. Object oriented programming shifts the emphasis and focuses first on the data structure and only secondarily on the procedures. More importantly, object oriented programming allows us to analyze and design programs in a natural manner. We can think in terms of runways and aircraft instead of focusing on either the behavior or the data structures of the runways and aircraft.

Table 1 shows a list of objects with corresponding attributes. Each physical object that is important to the runway incursion problem is modeled. The basic airplane or vehicle tracking algorithm is shown in Table 2 in a Program Design Language (PDL). The algorithm which handles sensor fusion, incursion avoidance and safety alerts is shown in a single program even though it is implemented as distributed system using both the central computer system 12 and the sensor microprocessors 44.

TABLE 1

<u>OBJECT</u>	<u>ATTRIBUTE</u>	<u>DESCRIPTION</u>
5	Sensor	Location
		X & Y coordinates of sensor
		Circuit
		AC wiring circuit name & number
		Unique_address
		Net address for this sensor and its mate
		Lamp_intensity
		0% to 100% in 0.5% steps
10		Strobe_status
		Blink rate/off
		Strobe-delay
		From start signal
		Sensor_status
		Detect/no detect
		Sensor_type
		IR, laser, proximity, etc.
15	Runway	Name
		22R, 27, 33L, etc.
		Location
		X & Y coordinates of start of center line
		Length
		In feet
		Width
		In feet
20		Direction
		In degrees from north
		Status
		Not_active, active_takeoff, active_landing, alarm
		Sensors (MV)
		List of lights/sensors along this runway
		Intersections (MV)
		List of intersections
25		Vehicles
		List of vehicles on the runway
	Taxiway	Name
		Name of taxiway
		Location
		X & Y coordinates of start of center line
		Length
		In feet
30		Width
		In feet
		Direction
		In degrees from north
		Status
		Not active, active, alarm
		Sensors (MV)
		List of intersections
35		Hold_Locations
		List of holding locations
		Vehicles (MV)
		List of vehicles on the runway

40

45

50

55

	Intersection	Name	Intersection Name
		Location	Intersection of two center lines
5		Status	Vacant/Occupied
		Sensors (MV)	List of sensors creating intersection border
	Aircraft	Airline	United
		Model	727-200
10		Tail-number	N3274Z
		Empty_weight	9.5 tons
		Freight_weight	2.3 tons
		Fuel_weight	3.2 tons
15		Top_speed	598 mph
		V1_speed	100 mph
		V2_speed	140 mph
		Acceleration	0.23 g's
20		Deceleration	0.34 g's

MV = Multi-variable or array

25

Table 2

```

while (forever)
  | if (edge light shows a detection)
  | | if (adjacent light also shows a detection sensor fusion)
  | | | /* CONFIRMED DETECTION */
  | | | if (previous block showed a detection)
  | | | | /* ACCEPT HANDOFF */
  | | | | Update aircraft position and speed
  | | | else
  | | | | /* MAY BE AN ANIMAL OR SERVICE TRUCK */
  | | | | Alert operator to possible incursion
  | | | | /* MAY BE AN AIRCRAFT ENTERING THE SYSTEM */
  | | | | Start a new track
  | | else
  | | | Request status from adjacent light

```

50

55

```

| | | if (Adjacent light is OK)
| | | | /* NON CONFIRMED DETECTION */
5 | | | else
| | | | Flag adjacent light for repair
| | | endif
10 | | endif
| endif
| if (Edge light loses a detection AND status is OK)
| | if (Next block showed a detection)
15 | | | /* PROPER HANDOFF */
| | | else
| | | if (vehicle speed > = takeoff)
20 | | | | Handoff to departure control
| | | else
| | | | /* MISSING HANDOFF */
25 | | | | Alert operator to possible incursion
| | | | endif
| | | endif
30 | | endif
| endif
| /* CHECK FOR POSSIBLE COLLISIONS */
| for (all tracked aircraft)
35 | | Plot future position
| | if (position conflict)
| | | Alert operator to possible incursion
40 | | | endif
| | endif
| endif
| Update display
45 |
endwhile

```

Referring again to FIG. 1 and FIG. 2, the control of taxiway lighting intensity is usually done by placing all the lights on the same series circuit and then regulating the current in that circuit. In the present embodiment the intensity of the lamp 40 is controlled by sending a message with the light intensity value to the microprocessor 44 located within the light assembly 20_{1-n}. The message allows for intensity settings in the range of 0 to 100% in 0.5% steps. The use of photocell 46 to check the light output allows a return message to be sent if the bulb does not respond. This in turn generates a maintenance report on the light. The strobe light 48 provides an additional optional capability under program control of the microprocessor 44. Each of the microprocessors 44 in the edge light assemblies 20 is individually addressable. This means every lamp on the field is controlled individually by the central computer system 12.

The system 10 can be programmed to provide an Active Runway Indicator by using the strobe lights 48 in those edge light assemblies 20_{1-n} located on the runway 64 to continue the approach light "rabbit" strobe

pattern all the way down the runway. This lighting pattern could be turned-on as a plane is cleared for landing and then turned-off after the aircraft has touched down. A pilot approaching the runway along an intersecting taxiway would be alerted in a clear and unambiguous way that the runway was active and should not be crossed.

5 If an incursion was detected the main computers 26, 28 could switch the runway strobe lights 48 from the "rabbit" pattern to a pattern that alternatively flashes either side of the runway in a wig-wag fashion. A switch to this pattern would be interpreted by the pilot of an arriving aircraft as a wave off and a signal to go around. The abrupt switch in the pattern of the strobes would be instantaneously picked up by the air crew in time for them to initiate an aborted landing procedure.

10 During Category III weather conditions both runway and taxiway visibility are very low. Currently radio based landing systems are used to get the aircraft from final approach to the runway. Once on the runway it is not always obvious which taxiways are to be used to reach the airport terminal. In system 10 the main computers 26,28 can control the taxiway lamps 40 as the means for guiding aircraft on the ground during CAT III conditions. Since the intensity of the taxiway lamps 40 can be controlled remotely, the lamps just in front of
15 an aircraft could be intensified or flashed as a means of guiding it to the terminal.

Alternatively, a short sequence of the "rabbit" pattern may be programmed into the taxiway strobes just in front of the aircraft. At intersections, either the unwanted paths may have their lamps turned off or the entrance to the proper section of taxiway may flash directing the pilot to head in that direction. Of course in a smart system only those lights directly in front of a plane would be controlled, all other lamps on the field would
20 remain in their normal mode.

Referring now to FIG. 9, a block diagram is shown of the data flow within the system 10 (as shown in FIG. 1 and FIG. 5). The software modules are shown that are used to process the data within the computers 26, 28 of the central computer system 12. The tracking of aircraft and other vehicles on the airport operates under the control of a sensor fusion software module 101 which resides in the computers 26, 28. The sensor fusion
25 software module 101 receives data from the plurality of sensors 50, a sensor 50 being located in each edge light assembly 20_n which reports the heat level detected, and this software module 101 combines this information through the use of rule based artificial intelligence to create a complete picture of all ground traffic at the airport on a display 30 of the central computer system 12.

The tracking algorithm starts a track upon the first report of a sensor 50 detecting a heat level that is above the ambient background level of radiation. This detection is then verified by checking the heat level reported by the sensor directly across the pavement from the first reporting sensor. This secondary reading is used to confirm the vehicle detected and to eliminate false alarms. After a vehicle has been confirmed the sensors adjacent to the first reporting sensor are queried for changes in their detected heat level. As soon as one of the adjacent sensors detects a rise in heat level a direction vector for the vehicle can be established. This process continues as the vehicle is handed off from sensor to sensor in a bucket brigade fashion as shown in FIG. 7. Vehicle speed can be roughly determined by calculating the time between vehicle detection by adjacent sensors. This information is combined with information from a system data base on the location of each sensor to calculate the velocity of the target. Due to hot exhaust or jet blast, the sensors behind the vehicle may not return to a background level immediately. Because of these condition, the algorithm only uses the first four
30 sensors (two on either side of the taxiway) to calculate the vehicles position. The vehicle is always assumed to be on the centerline of the pavement and between the first four reporting sensors.

Vehicle identification can be added to the track either manually or automatically by an automated source that can identify a vehicle by its position. An example would be prior knowledge of the next aircraft to land on a particular runway. Tracks are ended when a vehicle leaves the detection system. This can occur in one of
35 two ways. The first way is that the vehicle leaves the area covered by the sensors 50. This is determined by a vehicle track moving in the direction of a gateway sensor and then a lack of detection after the gateway sensor has lost contact. A second way to leave the detection system is for a track to be lost in the middle of a sensor array. This can occur when an aircraft departs or a vehicle runs onto the grass. Takeoff scenarios can be determined by calculating the speed of the vehicle just before detection was lost. If the vehicle speed was increasing and above rotation speed then the aircraft is assumed to have taken off. If not then the vehicle is
40 assumed to have gone on to the grass and an alarm is sounded.

Referring to FIG. 5 and FIG. 9, the ground clearance routing function is performed by the speech recognition unit 33 along with the ground clearance compliance verifier software module 103 running on the computers 26,28. This software module 103 comprises a vehicle identification routine, clearance path routing,
45 clearance checking routine and a path checking routine.

The vehicle identification routine is used to receive the airline name and flight number (i.e. "Delta 374") from the speech recognition unit 33 and it highlights the icon of that aircraft on the graphic display of the airport on display 30.

The clearance path routine takes the remainder of the controller's phrase (i.e. "outer taxiway to echo, hold short of runway 15 Left") and provides a graphical display of the clearance on the display 30 showing the airport.

The clearance checking routine checks the clearance path for possible conflict with other clearances and vehicles. If a conflict is found the portion of the path that would cause an incursion is highlighted in a blinking red and an audible indication is given to the controller via speaker 32.

The path checking routine checks the actual path of the vehicle as detected by the sensors 50 after the clearance path has been entered into the computers 26, 28 and it monitors the actual path for any deviation. If this routine detects that a vehicle has strayed from the assigned course, the vehicle icon on the graphic display of the airport flashes and an audible indicator is given to the controller via speaker 32 and optionally the vehicle operator via radio 37.

The airport vehicle incursion avoidance system 10 operates under the control of safety logic routines which reside in the collision detection software module 104 running on computers 26, 28. The safety logic routines receive data from the sensor fusion software module 101 location program via the tracker software module 102 and interpret this information through the use of rule based artificial intelligence to predict possible collisions or runway incursions. This information is then used by the central computer system 12 to alert tower controllers, aircraft pilots and truck operators to the possibility of a runway incursion. The tower controllers are alerted by the display 30 along with a computer synthesized voice message via speaker 32. Ground traffic is alerted by a combination of traffic lights, flashing lights, stop bars and other alert lights 34, lamps 40 and 48, and computer generated voice commands broadcast via radio 36.

Knowledge based problems are also called fuzzy problems and their solutions depend upon both program logic and an interface engine that can dynamically create a decision tree, selecting which heuristics are most appropriate for the specific case being considered. Rule based systems broaden the scope of possible applications. They allow designers to incorporate judgement and experience, and to take a consistent solution approach across an entire problem set.

The programming of the rule based incursion detections software is very straight forward. The rules are written in English allowing the experts, in this case the tower personnel and the pilots, to review the system at an understandable level. Another feature of the rule based system is that the rules stand alone. They can be added, deleted or modified without affecting the rest of the code. This is almost impossible to do with code that is created from scratch. An example of a rule we might use is:

```
If (Runway_Status = Active)
    then (Stop_Bar_Lights = RED).
```

This is a very simple and straight forward rule. It stands alone requiring no extra knowledge except how Runway_Status is created. So let's make some rules affecting Runway_Status.

```
If (Departure = APPROVED) or (Landing = IMMINENT),
    then (Runway_Status = ACTIVE).
```

For incursion detection, another rule is:

```
If (Runway_Status = ACTIVE) and (Intersection = OCCUPIED),
    then (Runway_Incursion = TRUE).
```

Next, detect that an intersection of a runway and taxiway are occupied by the rules:

```
If (Intersection_Sensors = DETECT),
    then (Intersection = OCCUPIED).
```

To predict that an aircraft will run a Hold Position stop, the following rule is created:

```
If (Aircraft_Stopping_Distance > Distance_to_Hold_Position),
    then (Intersection = OCCUPIED).
```

In order to show that rules can be added without affecting the reset of the program, assume that after a demonstration of the system 10 to tower controllers, they decided that they wanted a "Panic Button" in the tower to override the rule based software in case they spot a safety violation on the ground. Besides installing the button, the only other change would be to add this extra rule.

```
If (Panic_button = PRESSED),
    then (Runway_Incursion = TRUE).
```

It is readily seen that the central rule based computer program is very straight forward to create, understand and modify. As types of incursions are defined, the system 10 can be upgraded by adding more rules.

Referring again to FIG. 9, the block diagram shows the data flow between the functional elements within the system 10 (FIG. 1). Vehicles are detected by the sensor 50 in each of the edge light assemblies 20_{1-n}. This information is passed over the local operating network (LON) via edge light wiring 21_{1-n} to the LON bridges 22_{1-n}. The individual message packets are then passed to the redundant computers 26 and 28 over the wide area network (WAN) 14 to the WAN interface 108. After arriving at the redundant computers 26 and 28, the message packet is checked and verified by a message parser software module 100. The contents of the mes-

sage are then sent to the sensor fusion software module 101. The sensor fusion software module 101 is used to keep track of the status of all the sensors 50 on the airport; it filters and verifies the data from the airport and stores a representative picture of the sensor array in a memory. This information is used directly by the display 30 to show which sensors 50 are responding and used by the tracker software module 102. The tracker software module 102 uses the sensor status information to determine which sensor 50 reports correspond to actual vehicles. In addition, as the sensor reports and status change, the tracker software module 102 identifies movement of the vehicles and produces a target location and direction output. This information is used by the display 30 in order to display the appropriate vehicle icon on the screen.

The location and direction of the vehicle is also used by the collision detection software module 104. This module checks all of the vehicles on the ground and plots their expected course. If any two targets are on intersecting paths, this software module generates operator alerts by using the display 30, the alert lights 34, the speech synthesis unit 29 coupled to the associated speaker 32, and the speech synthesis unit 31 coupled to radio 37 which is coupled to antenna 39.

Still referring to FIG. 9, another user of target location and position data is the ground clearance compliance verifier software module 103. This software module 103 receives the ground clearance commands from the controller's microphone 35 via the speech recognition unit 33. Once the cleared route has been determined, it is stored in the ground clearance compliance verifier software module 103 and used for comparison to the actual route taken by the vehicle. If the information received from the tracker software module 102 shows that the vehicle has deviated from its assigned course, this software module 103 generates operator alerts by using the display 30, the alert lights 34, the speech synthesis unit 29 coupled to speaker 32, and the speech synthesis unit 31 coupled to radio 37 which is coupled to antenna 39.

The keyboard 27 is connected to a keyboard parser software module 109. When a command has been verified by the keyboard parser software module 109, it is used to change display 30 options and to reconfigure the sensors and network parameters. A network configuration data base 106 is updated with these reconfiguration commands. This information is then turned into LON message packets by the command message generator 107 and sent to the edge light assemblies 20_{1-n} via the WAN interface 108 and the LON bridges 22_{1-n} .

Referring now to FIG. 1 and FIG. 10, FIG. 10 shows a pictorial diagram of an infrared vehicle identification system 109 invention comprising an infrared (IR) transmitter 112 mounted on an airplane 110 wheel strut 111 and an IR receiver 128 which comprises a plurality of edge light assemblies 20_{1-n} of an airport lighting system also shown in FIG. 1. The combination of the IR transmitter 112 mounted on aircraft and/or other vehicles and a plurality of IR receivers 128 located along runways and taxiways form the infrared vehicle identification system 109 for use at airports for the safety, guidance and control of surface vehicles in order to provide positive detection and identification of all aircraft and other vehicles and to prevent runway incursions. Runway incursions generally occur when aircraft or other vehicles get onto a runway and conflict with aircraft cleared to land or takeoff on that same runway. All such incursions are caused by human error.

Referring now to FIG. 11, a block diagram of the IR transmitter 112 is shown comprising an embedded microprocessor 118 having DC power 114 inputs from the aircraft host or vehicle on which the IR transmitter 112 is mounted and an ID switch 116 within the aircraft for entering vehicle identification data which is received by the IR transmitter 112 on a serial line. Vehicle position information is provided to the IR transmitter 112 from a vehicle position receiver 117 which may be embodied by a global positioning system (GPS) receiver readily known in the art. The output of embedded microprocessor 118 feeds an IR emitter comprising a light emitting diode (LED) array 120. When power is applied to the IR transmitter 112, the microprocessor continuously outputs a coded data stream 121 (FIG. 13) which is transmitted by the IR LED array 120. The embedded microprocessor 118 may be embodied by microprocessor Model MC 6803 or equivalent manufactured by Motorola Microprocessor Products of Austin; Texas. The IR LED array 120 may be embodied by IR LED Devices manufactured by Harris Semiconductor of Melbourne, Florida.

Referring now to FIG. 12, a top view of the IR transmitter 112 comprising the IR LED array 120 mounted on an airplane wheel strut 111 is shown. The IR LED array 120 comprises a plurality of high power LEDs each having a beam width of 15° . By placing thirteen LEDs in an array, a 195° area can be covered. The IR LED array 120 illuminates edge light assemblies 20_{1-4} along the edges of the runway 64. Each of the edge light assemblies 20_{1-4} comprises an IR receiver 128.

Referring now to FIG. 13, the coded data stream emitted from the IR transmitter 112 comprises six separate fields. The first field is called timing pattern 122 and comprises a set of equally spaced pulses. The second field is called unique word 123 which marks the beginning of a message. The third field is called character count 124 which specifies the number of characters in a message. The fourth field is called vehicle identification number 125. The fifth field is called vehicle position 126 and provides latitude and longitude information.

The sixth field is called message checksum 127. The equally spaced pulses of the timing pattern 122 allow the IR receiver 128 to calculate the baud rate of a transmitted message and automatically adjust its internal timing to compensate for either a doppler shift or an offset in clock frequency. The checksum 126 field allows the IR receiver 128 to find the byte boundary. The character count 124 field is used to alert the IR receiver 128 in the edge light assemblies 20₁₋₄ as to the length of the message being received. The IR receiver 128 uses this field to determine when the message has ended and if the message was truncated.

The vehicle identification number 125 field comprises an airline flight number or a tail number of an aircraft or a license number of other vehicles. The actual number can be alpha-numeric since each character will be allocated eight (8) bits. An ASCII code which is known to those of ordinary skill in the art is an example of a code type that may be used. The only constraints on the vehicle ID number is that it be unique to the vehicle and that it be entered in the airport's central computer data base to facilitate automatic identification. The checksum 127 guarantees that a complete and correct message is received. If the message is interrupted for any reason, such as a blocked beam or a change in vehicle direction, it is instantly detected and the reception voided. This procedure reduces the number of false detects and guarantees that only perfect vehicle identification messages are passed on to the central computer system 12 at the airport tower.

Referring now to FIG. 1, FIG. 2, FIG. 10 and FIG. 14, a block diagram of the IR receiver 128 is shown in FIG. 14 which comprises an IR sensor 130 connected to an edge light assembly 20_{1-n} shown in FIG. 1, FIG. 2 and FIG. 10, on an airport. In FIG. 14, only the relevant portions of FIG. 2 are shown, but it should be understood that all of the elements of the edge light assembly 20_{1-n} shown in FIG. 2 are considered present in FIG. 14. The IR receiver 128 comprises the IR sensor 130 which receives the coded data stream 121 (FIG. 13) from the transmitter 112. The output of the IR sensor 130 is fed to the microprocessor 44 for processing by an IR message routine 136 for detecting the data message. A vehicle sensor routine 138 in microprocessor 44 processes signals from the vehicle sensor 50 for detecting an aircraft or other vehicles. The IR message routine 136 is implemented with software within the microprocessor 44 as shown in the flow chart of FIG. 15. The vehicle sensor routine 138 is also implemented with software within the microprocessor 44 as shown in the flow chart of FIG. 16. The outputs of the IR message routine 136 and vehicle sensor routine 138 are processed by the microprocessor 44 which sends via the power line modem 54 the identified aircraft or vehicle and their position data over the edge light wiring 21_{1-n} communication lines to the central computer system 12 shown in FIG. 1 at the airport terminal or control tower. The IR sensor 130 may be embodied with Model RY5BD01 IR sensor manufactured by Sharp Electronics, of Paramus, New Jersey. The microprocessor 44 may be embodied by the VLSI Neuron[®] Chip, manufactured by Echelon Corporation, of Palo Alto, California.

Referring to FIG. 15, a flow chart of the IR message routine 136 is shown which is a communication protocol continuously performed in the microprocessor 44 of the IR receiver 128. After an IR signal is detected 150 the next action is transmitter acquisition or to acquire timing 152. The microprocessor 44 looks for the proper timing relationship between the received IR pulses. If the correct on/off ratio exists, the microprocessor 44 calculates the baud rate from the received timing and waits to acquire the unique word 156 signifying byte boundary and then checks for the capture of the character count 160 field byte. After the character count is known, the microprocessor 44 then captures each character in the vehicle ID 162 field and stores them away in a buffer. It then captures vehicle position 163 including latitude and longitude data. If the IR coded data stream is disrupted before all the vehicle ID characters are received, the microprocessor 44 aborts this reception try and returns to the acquisition or IR detected 150 state. After all characters have been received, the checksum 164 is calculated. If the checksum matches 166, then the message is validated and the vehicle ID relayed 168 to the central computer system 12. With this scheme the microprocessor 44 is implementing both the physical and a link layer of the OSI protocol by providing an error free channel.

Referring now to FIG. 16, a flow chart is shown of the vehicle sensor routine 138 software running on microprocessor 44. This software routine 138 runs as a continuous loop. An internal timer is continuously checked for a time out condition (timer = zero 170). As soon as the timer expires the analog value from sensor 50 is read (Read Sensor Value 171) by the microprocessor 44 and the timer is reset to the poll_time 172 variable downloaded by the central computer system 12. This sensor value is compared against a predetermined detection threshold 173 and downloaded by the central computer system 12. If the sensor value is less than the detection threshold, the microprocessor 44 sets the network variable prelim_detect to the FALSE state 174. If the sensor value is greater than the detection threshold the microprocessor 44 sets the network variable prelim_detect to the TRUE state 175. If a preliminary detection is declared, the program then checks to see what reporting mode 176 is in use. If all detections are required to be sent to the central computer system 12, then this sensor value 180 is sent. If only those readings that are different from the previous reading by a predetermined delta and download by the central computer system 12, then this check is made 177. If the change is greater than the delta 177, the program checks to see if it should confirm the detection 178 to eliminate any

false alarms. If a confirmation is not required, then this sensor value 181 is sent. If in the confirmation mode, then the adjacent sensor's 179 preliminary network variable is checked. If the adjacent sensor has also detected the object, then the current sensor value 182 is sent.

5 This concludes the description of the preferred embodiment. However, many modifications and alterations will be obvious to one of ordinary skill in the art without departing from the spirit and scope of the inventive concept. Therefore, it is intended that the scope of this invention be limited only by the appended claims.

10 **Claims**

1. A vehicle identification system for identifying aircraft and other vehicles on surface pathways including runways and other areas of an airport comprising:
 - means disposed on said aircraft and other vehicles for transmitting identification message data;
 - means disposed in each of a plurality of light assembly means on said airport for receiving and decoding said message data from said transmitting means;
 - means for providing power to each of said plurality of light assembly means;
 - means for processing said decoded identification message data generated by said receiving and decoding means in each of said plurality of light assembly means;
 - means for providing data communication between each of said light assembly means and said processing means; and
 - said processing means comprises means for providing a graphic display of said airport comprising symbols representing said aircraft and other vehicles, each of said symbols having said identification message data displayed.
- 25 2. The vehicle identification system as recited in Claim 1 wherein said transmitting means comprises:
 - means for creating a unique message data which includes aircraft and flight identification; and
 - infrared means coupled to said message creating means for transmitting a coded stream of said message data.
- 30 3. The vehicle identification system as recited in Claim 3 wherein:
 - said message data further includes position information.
4. The vehicle identification system as recited in Claim 1 wherein:
 - said receiving and decoding means comprises an infrared sensor.
- 35 5. The vehicle identification system as recited in Claim 3 wherein:
 - said receiving and decoding means comprises microprocessor means coupled to said infrared sensor for decoding said message data.
- 40 6. The vehicle identification system as recited in Claim 1 wherein:
 - said plurality of light assembly means being arranged in two parallel rows along runways and taxiways of said airport.
- 45 7. The vehicle identification system as recited in Claim 1 wherein said light assembly means comprises:
 - light means coupled to said lines of said power providing means for lighting said airport;
 - vehicle sensing means for detecting aircraft or other vehicles on said airport;
 - microprocessor means coupled to said receiving and decoding means, said light means, said vehicle sensing means and said data communication means for decoding said identification message data;
 - and
 - said data communication means being coupled to said microprocessor means and said lines of said power providing means.
- 50 8. The vehicle identification system as recited in Claim 1 wherein:
 - said symbols representing aircraft and other vehicles comprise icons having a shape indicating type of aircraft or vehicle.
- 55 9. The vehicle identification system as recited in Claim 1 wherein:
 - said processing means determines a location of said symbols on said graphic display of said airport in accordance with data received from said light assembly means.

10. A vehicle identification system for identifying aircraft and other vehicles on surface pathways including runways and other areas of an airport comprising:
means disposed on said aircraft and other vehicles for creating a unique message including aircraft and flight identification;
5 infrared means coupled to said message creating means for transmitting a coded stream of said message data;
infrared means disposed in each of a plurality of light assembly means on said airport for receiving said message data from said transmitting means;
10 microprocessor means coupled to said receiving means for decoding said message data;
means for providing power to each of said plurality of light assembly means;
means for processing said decoded message data generated by said decoding means in each of said plurality of light assembly means;
means for providing data communication between each of said light assembly means and said processing means; and
15 said processing means comprises means for providing a graphic display of said airport comprising symbols representing said aircraft and other vehicles, each of said symbols having said identification message data displayed.
11. The vehicle identification system as recited in Claim 10 wherein:
20 said message data further includes position information.
12. The vehicle identification system as recited in Claim 10 wherein:
said plurality of light assembly means being arranged in two parallel rows along runways and taxiways of said airport.
- 25 13. The vehicle identification system as recited in Claim 10 wherein said light assembly means comprises:
light means coupled to said lines of said power providing means for lighting said airport;
vehicle sensing means for detecting aircraft or other vehicles on said airport;
said microprocessor means coupled to said decoding means, said light means, said vehicle sensing means and said data communication means further processes a detection signal from said vehicle sensing means; and
30 said data communication means being coupled to said microprocessor means and said lines of said power providing means.
14. The vehicle identification system as recited in Claim 10 wherein:
35 said symbols representing aircraft and other vehicles comprise icons having a shape indicating type of aircraft or vehicle.
15. The vehicle identification system as recited in Claim 10 wherein:
40 said processing means determines a location of said symbols on said graphic display of said airport in accordance with data received from said light assembly means.
16. A vehicle identification system for surveillance and identification of aircraft and other vehicles on an airport comprising:
45 a plurality of light circuits on said airport, each of said light circuits comprises a plurality of light assembly means;
means for providing power to each of said plurality of light circuits and to each of said light assembly means;
means in each of said light assembly means for sensing ground traffic on said airport;
means disposed on said aircraft and other vehicles for transmitting identification message data;
50 means disposed in each of said light assembly means for receiving and decoding said message data from said transmitting means;
means for processing ground traffic data from said sensing means and decoded message data from each of said light assembly means for presentation on a graphic display of said airport;
means for providing data communication between each of said light assembly means and said processing means; and
55 said processing means comprises means for providing such graphic display of said airport comprising symbols representing said ground traffic, each of said symbols having direction, velocity and said identification message data displayed.

17. The vehicle identification system as recited in Claim 16 wherein:
each of said light circuits being located along the edges of taxiways or runways on said airport.
- 5 18. The vehicle identification system as recited in Claim 16 wherein:
said sensing means comprises infrared detectors.
- 10 19. The vehicle identification system as recited in Claim 16 wherein said transmitting means comprises:
means for creating unique message data which includes aircraft and flight identification; and
infrared means coupled to said message creating means for transmitting a coded stream of said
message data.
- 15 20. The vehicle identification system as recited in Claim 19 wherein:
said message data further comprises position information.
- 20 21. The vehicle identification system as recited in Claim 16 wherein:
said receiving and decoding means comprises an infrared sensor.
- 25 22. The vehicle identification system as recited in Claim 21 wherein:
said receiving and decoding means comprises microprocessor means coupled to said infrared sen-
sor for decoding said message data.
- 30 23. The vehicle identification system as recited in Claim 16 wherein:
said plurality of light assembly means of said light circuits being arranged in two parallel rows along
runways and taxiways of said airport.
- 35 24. The vehicle identification system as recited in Claim 16 wherein said light assembly means comprises:
light means coupled to said lines of said power providing means for lighting said airport;
said ground traffic sensing means for detecting aircraft or other vehicles on said airport;
microprocessor means coupled to said receiving and decoding means, said light means, said
ground traffic sensing means and said data communication means for decoding said identification mes-
sage data and processing a detection signal from said ground traffic sensing means; and
said data communication means being coupled to said microprocessor means and said lines of said
power providing means.
- 40 25. The vehicle identification system as recited in Claim 24 wherein:
said light assembly means further comprises a photocell means coupled to said microprocessor
means for detecting the light intensity of said light means.
- 45 26. The vehicle identification system as recited in Claim 24 wherein:
said light assembly means further comprises a strobe light coupled to said microprocessor means.
- 50 27. The vehicle identification system as recited in Claim 16 wherein:
said processing means comprises redundant computers for fault tolerance operation.
- 55 28. The vehicle identification system as recited in Claim 16 wherein:
said symbols representing said ground traffic comprise icons having a shape indicating type of air-
craft or vehicle.
29. The vehicle identification system as recited in Claim 16 wherein:
said processing means determines a location of said symbols on said graphic display of said airport
in accordance with said data receive from said light assembly means.
30. The vehicle identification system as recited in Claim 16 wherein:
said processing means determines a future path of said ground traffic based on a ground clearance
command, said future path being shown on said graphic display.
31. The vehicle identification system as recited in Claim 16 wherein:
said processing means further comprises means for predicting an airport incursion.
32. The vehicle identification system as recited in Claim 16 wherein said power providing means comprises:

constant current power means for providing a separate line to each of said plurality of light circuits;
and

network bridge means coupled to said constant current power means for providing a communication channel to said processing means for each line of said constant current power means.

5

33. A method of providing a vehicle identification system for identifying aircraft and other vehicles on surface pathways including runways and other areas of an airport comprising the steps of:
transmitting identification message data with means disposed on said aircraft and other vehicles;
receiving and decoding said message data from said transmitting means with means disposed in
10 each of a plurality of light assembly means on said airport;
providing power to each of said plurality of light assembly means;
processing said decoded identification message data generated by said receiving and decoding means in each of said plurality of light assembly means;
providing data communication on lines of said power providing means between each of said light
15 assembly means and said processing means; and
providing a graphic display of said airport with said processing means comprising symbols representing said aircraft and other vehicles, each of said symbols having said identification message data displayed.

20

34. The method as recited in Claim 33 wherein said step of transmitting identification message data comprises the steps of creating unique message data which includes aircraft and flight identification; and
transmitting a coded stream of said message data with infrared means coupled to said message
creating means.

25

35. The method as recited in Claim 34 wherein said step of transmitting message data further includes transmitting position information.

36. The method as recited in Claim 33 wherein said step of receiving and decoding said message data includes using an infrared sensor.

30

37. The method as recited in Claim 33 wherein said step of receiving and decoding said message data further comprises the step of coupling microprocessor means to said infrared sensor for decoding said message data.

35

38. The method as recited in Claim 33 wherein said step of receiving and decoding said message data with means disposed in said plurality of light assembly means further comprises the step of arranging said plurality of light assembly means in two parallel rows along runways and taxiways of said airport.

40

39. The method as recited in Claim 33 wherein said step of providing a graphic display comprising symbols representing aircraft and other vehicles further comprises the step of providing icons having a shape indicating type of aircraft or vehicle.

45

40. The method as recited in Claim 33 wherein said step of providing a graphic display comprises the step of determining a location of said symbols on said graphic display of said airport in accordance with data received from said light assembly means.

50

55

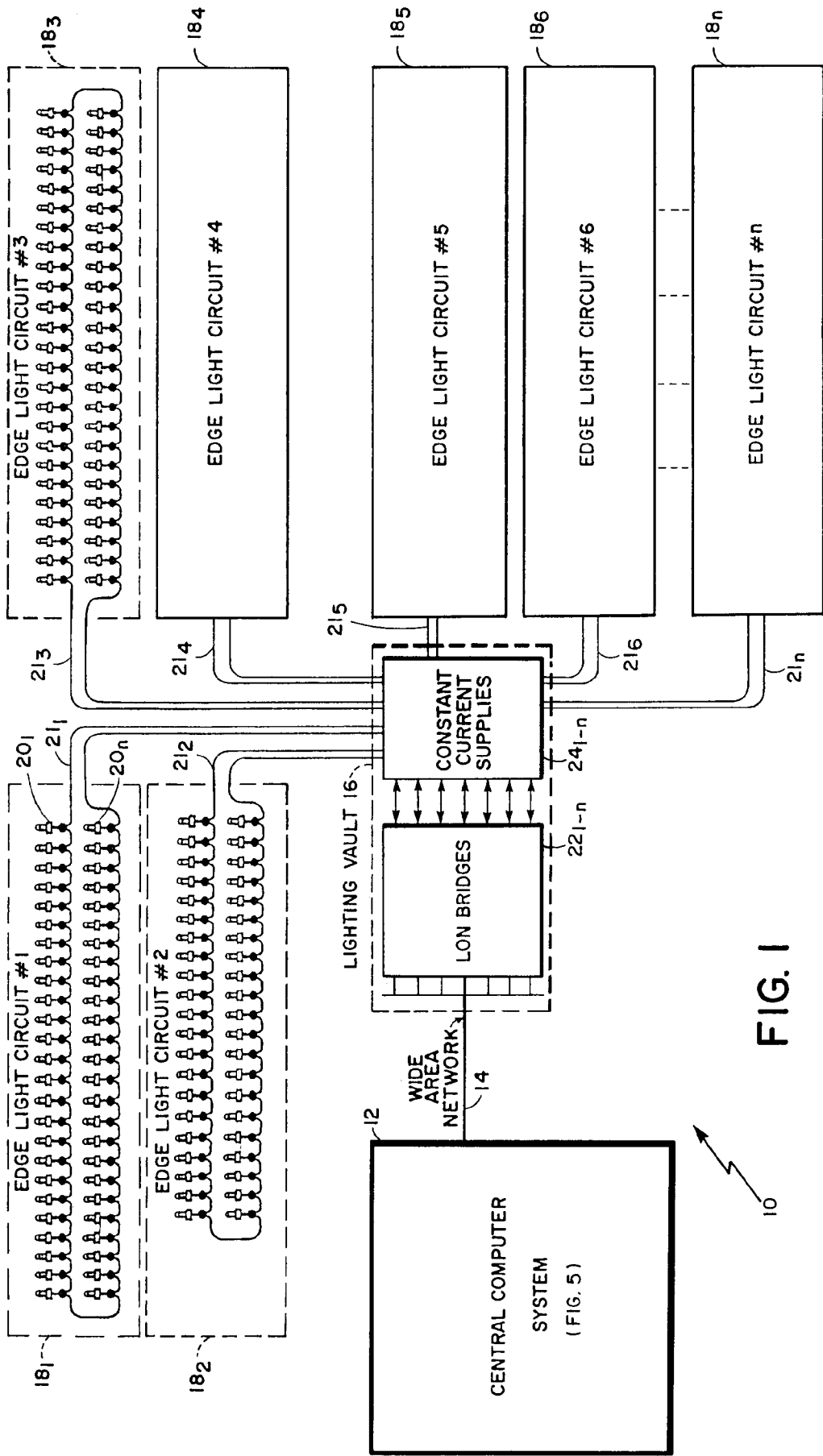

FIG. 1

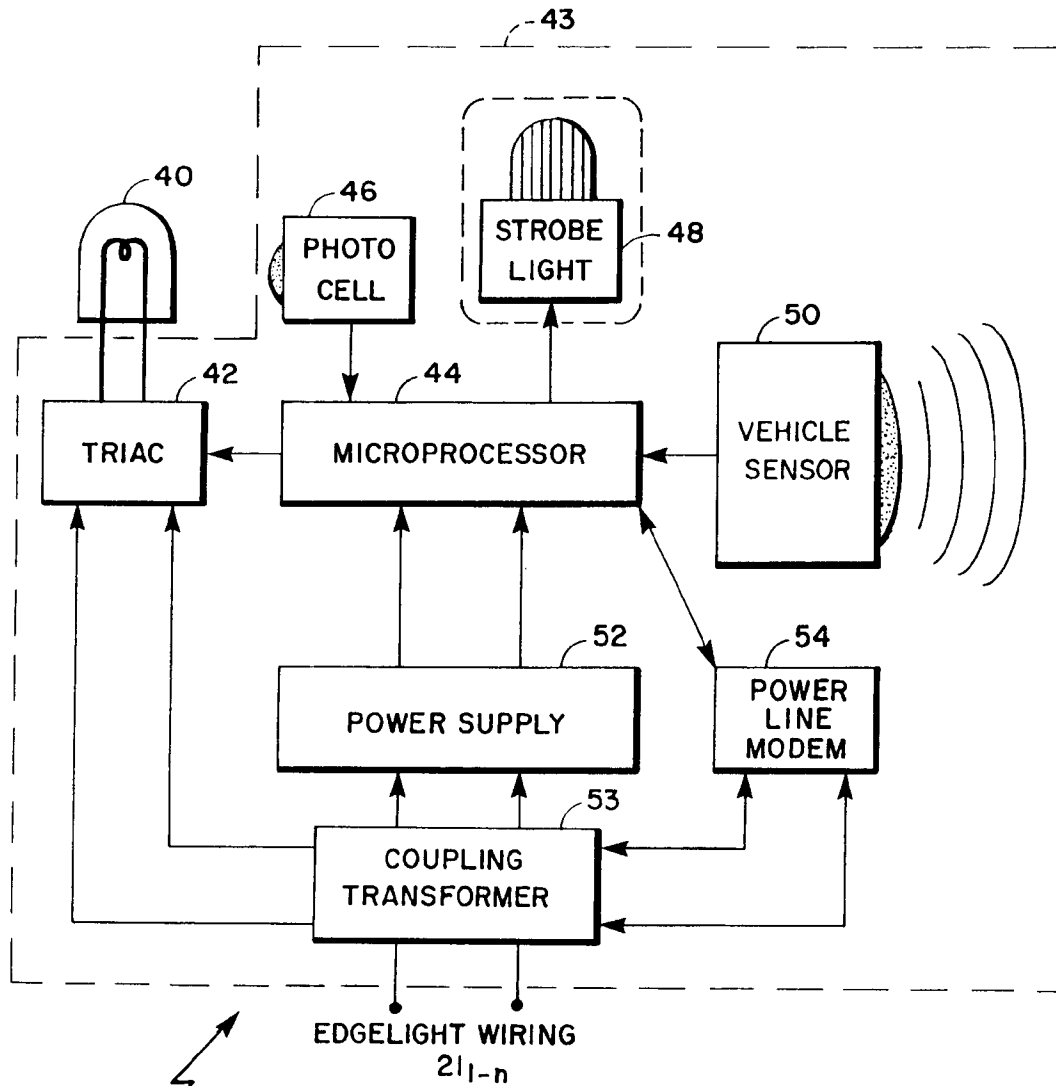

FIG. 2

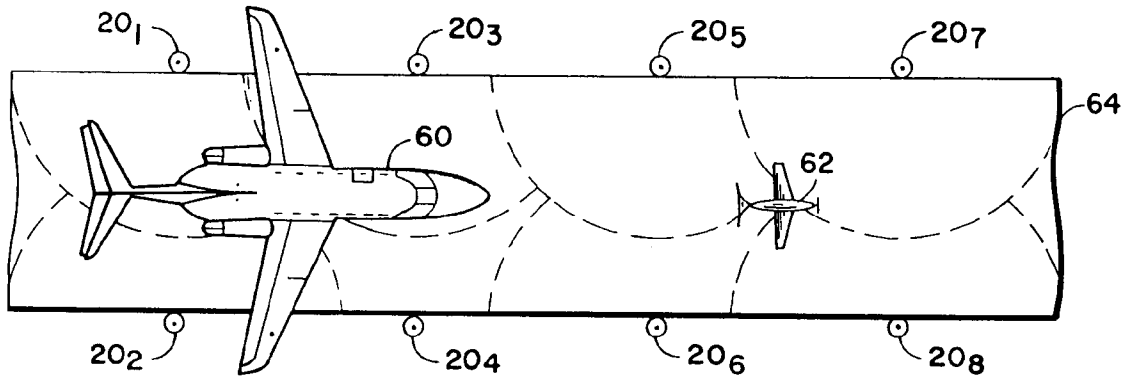

FIG. 4

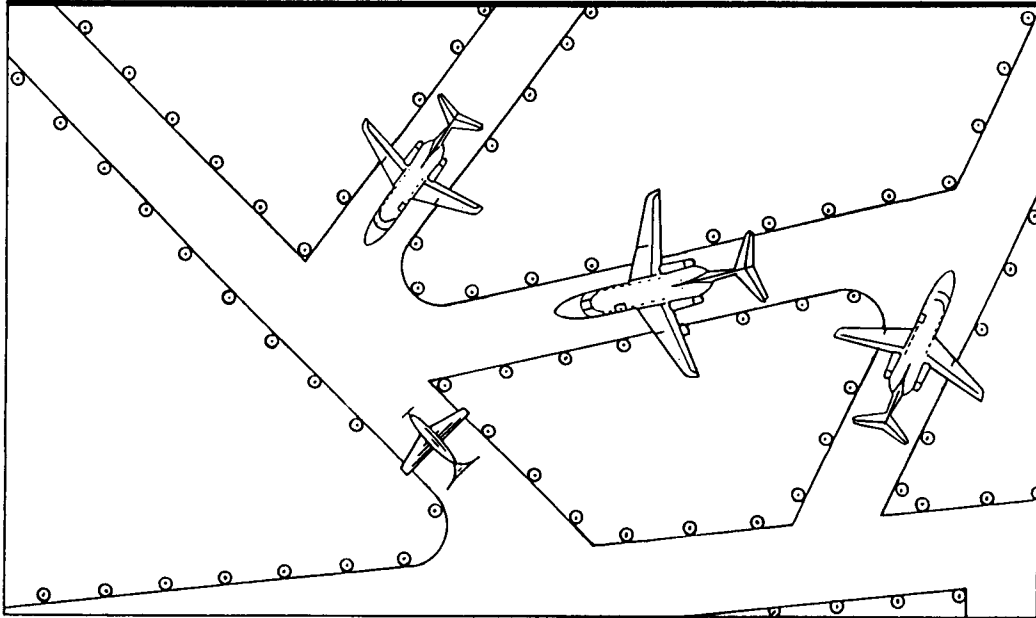

FIG. 8

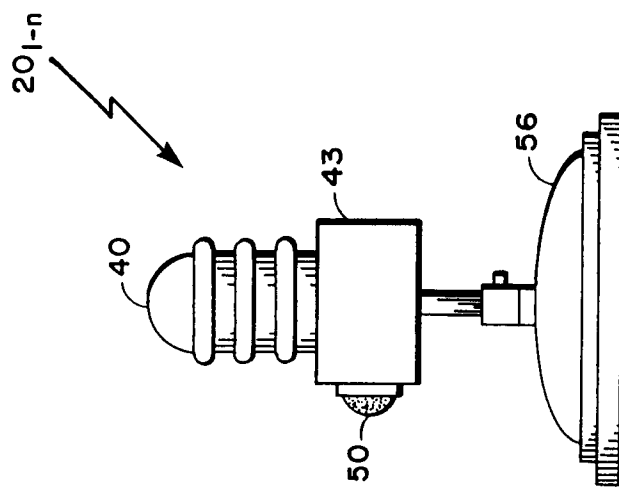

FIG. 3

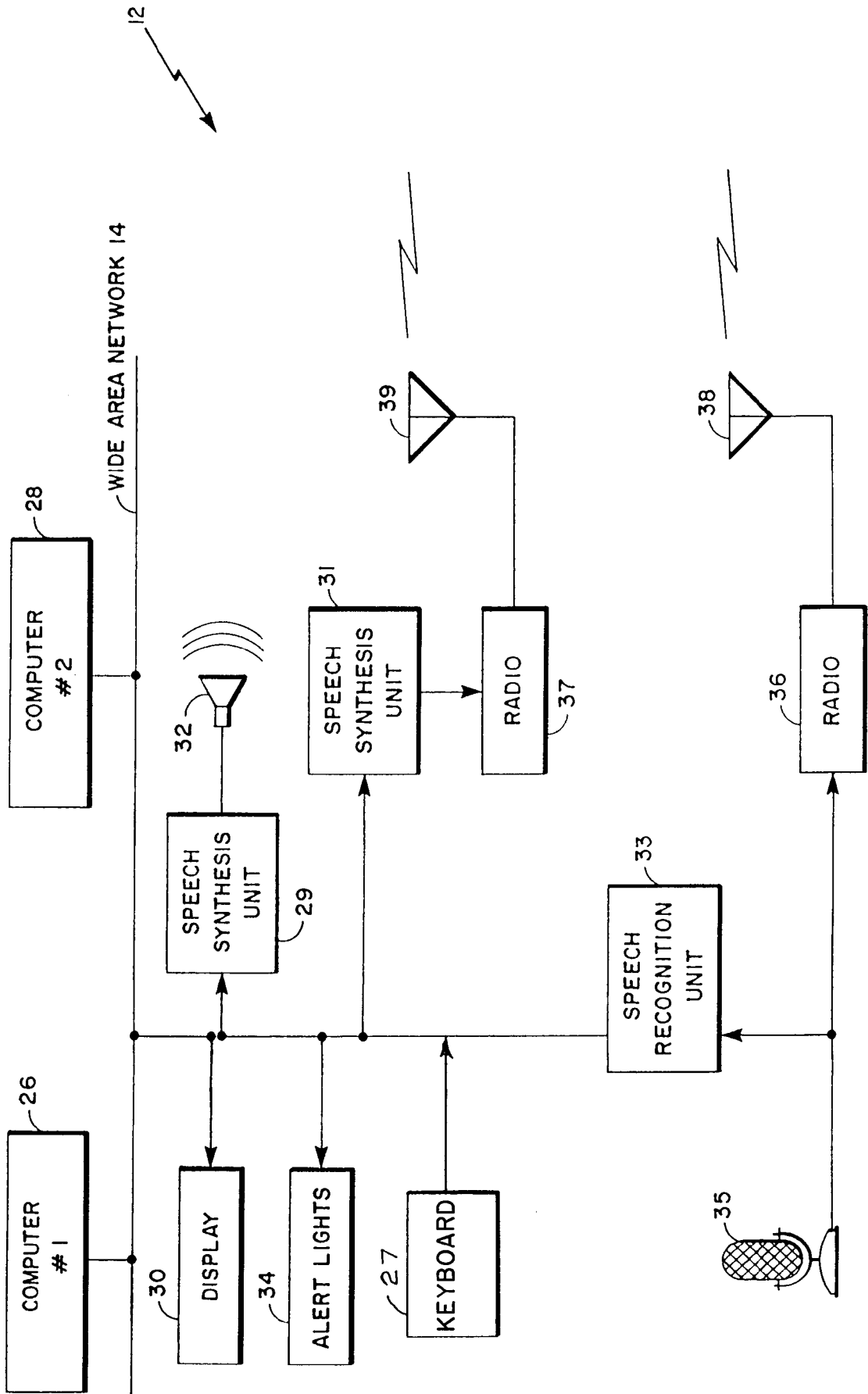

FIG. 5

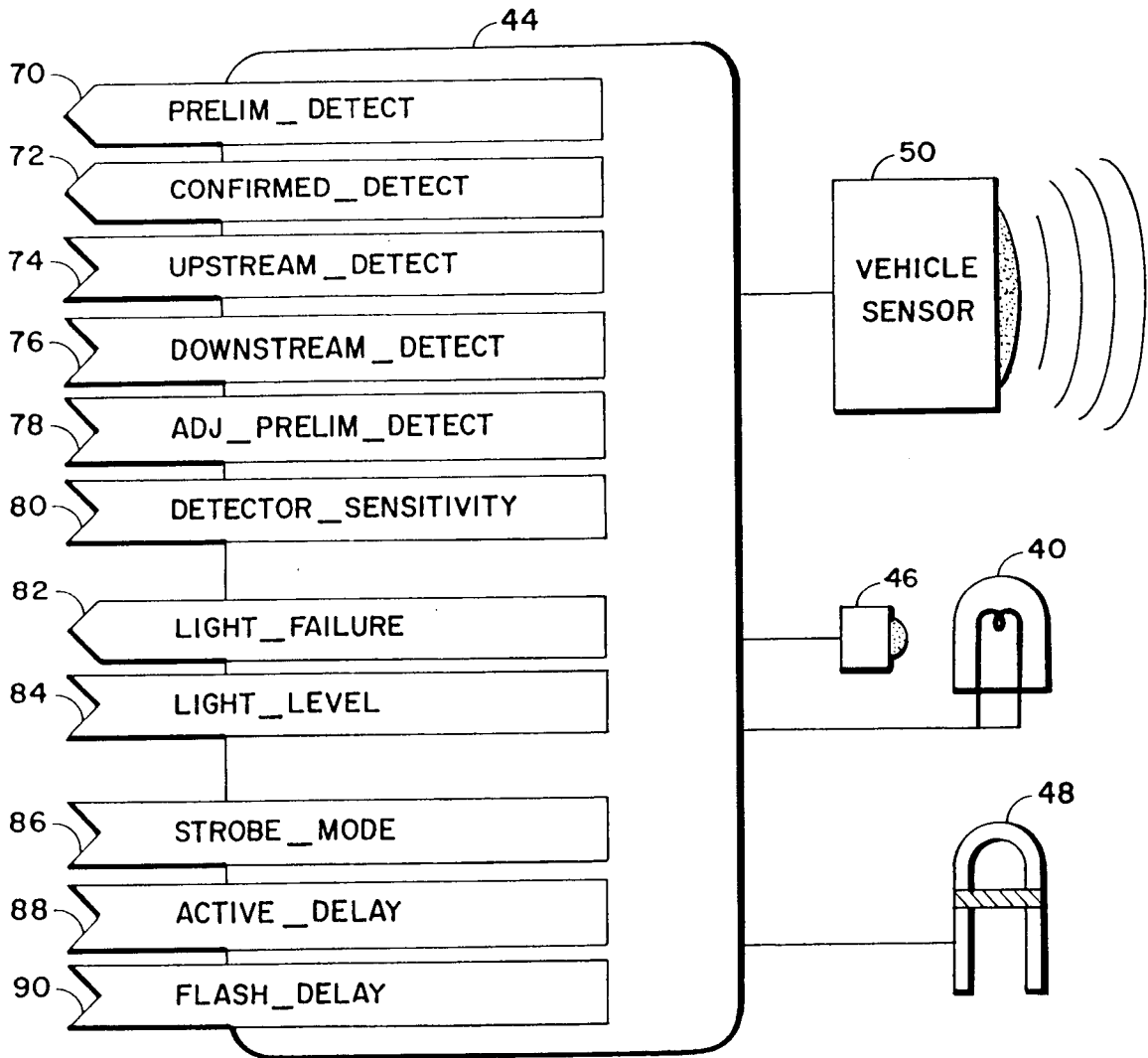

FIG. 6

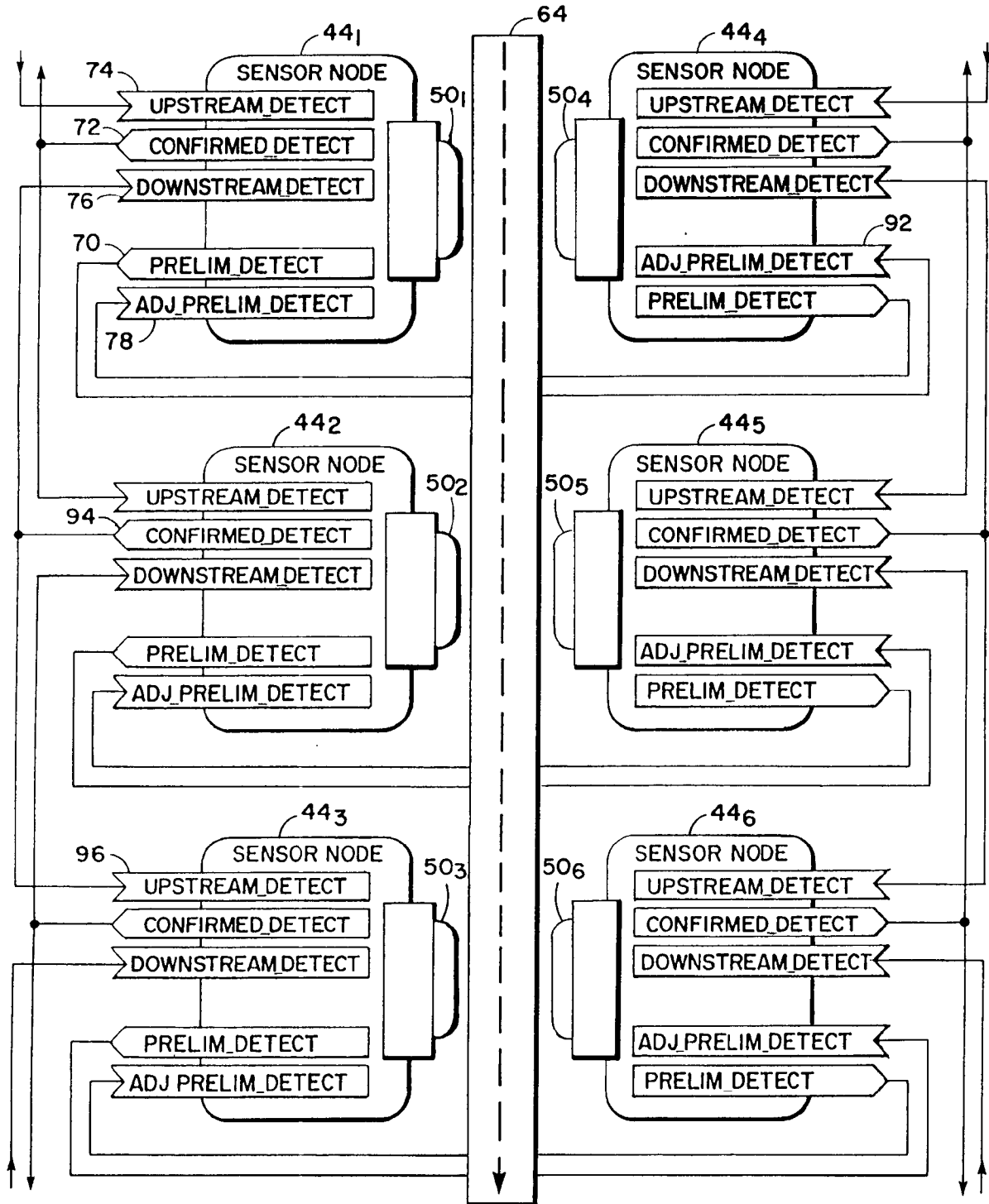

FIG. 7

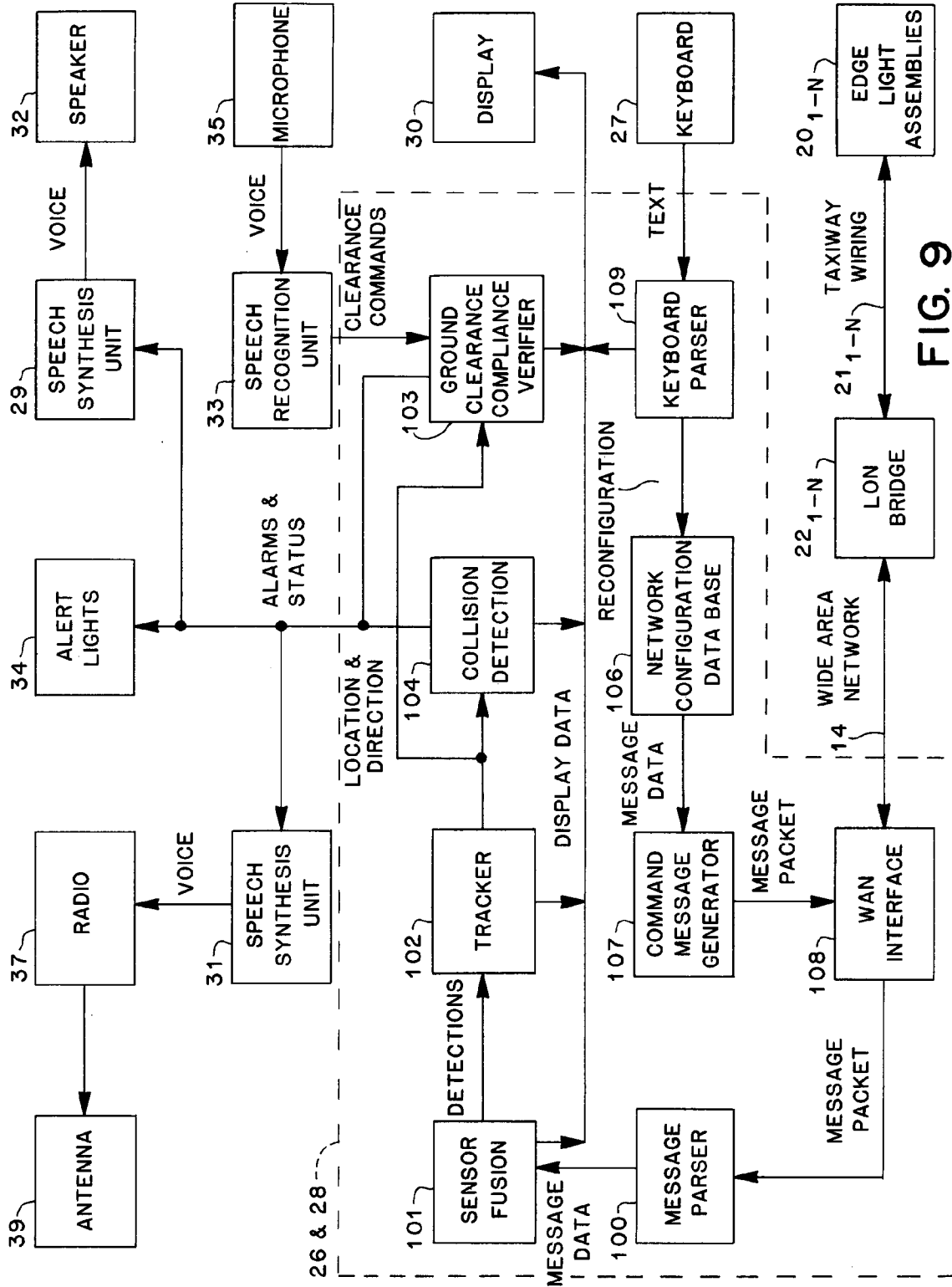

FIG. 9

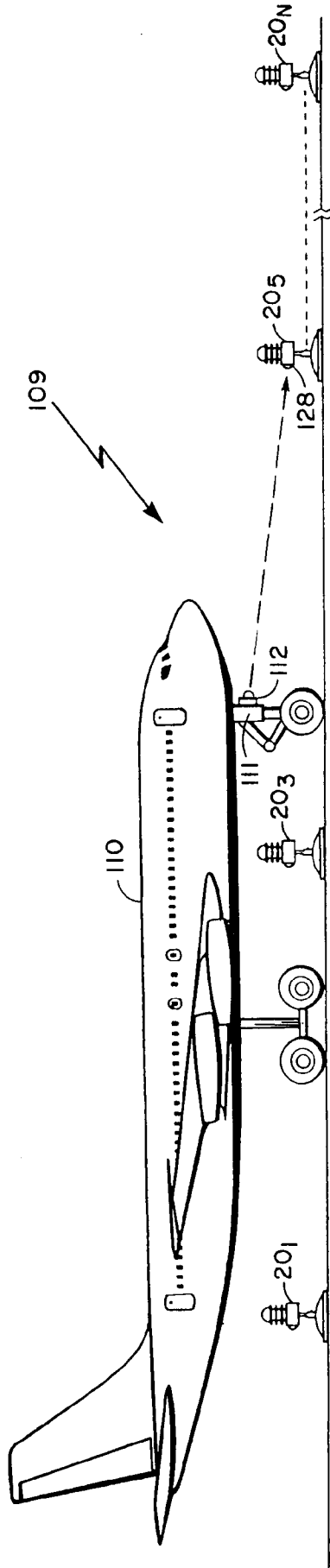

FIG. 10

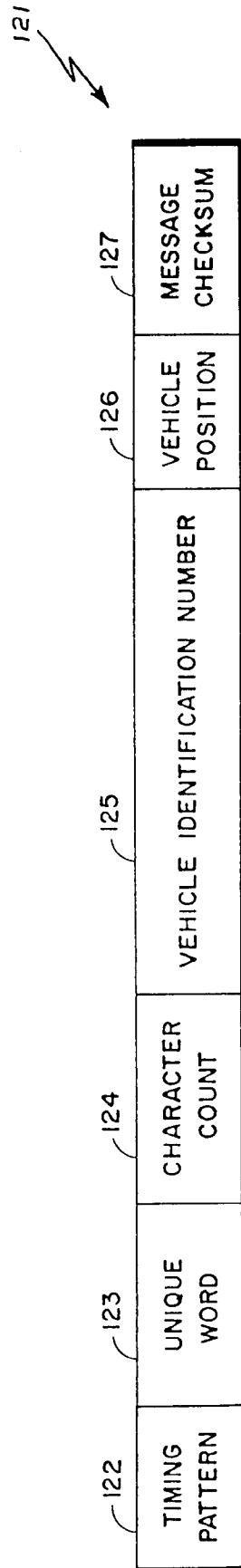

FIG. 13

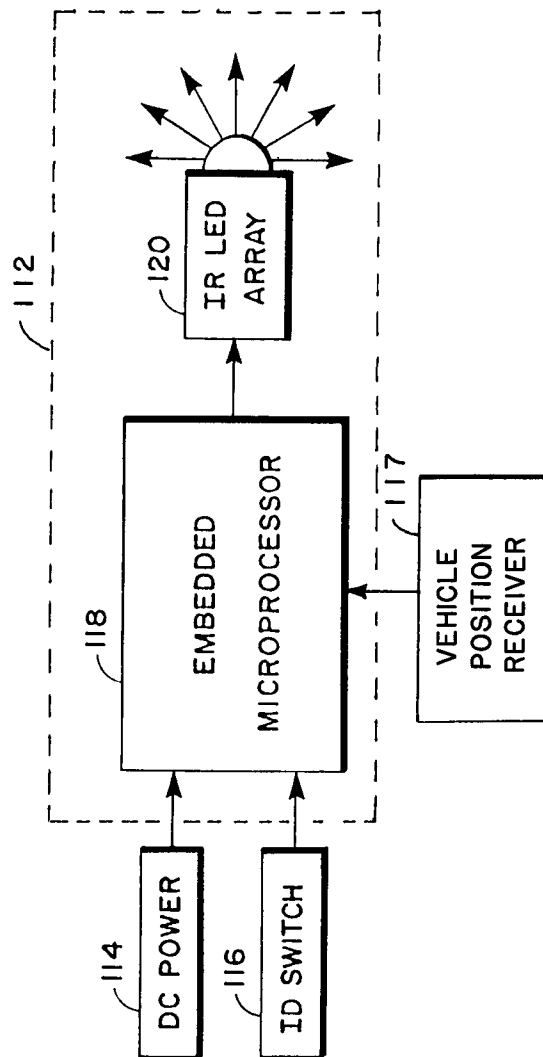

FIG. 11

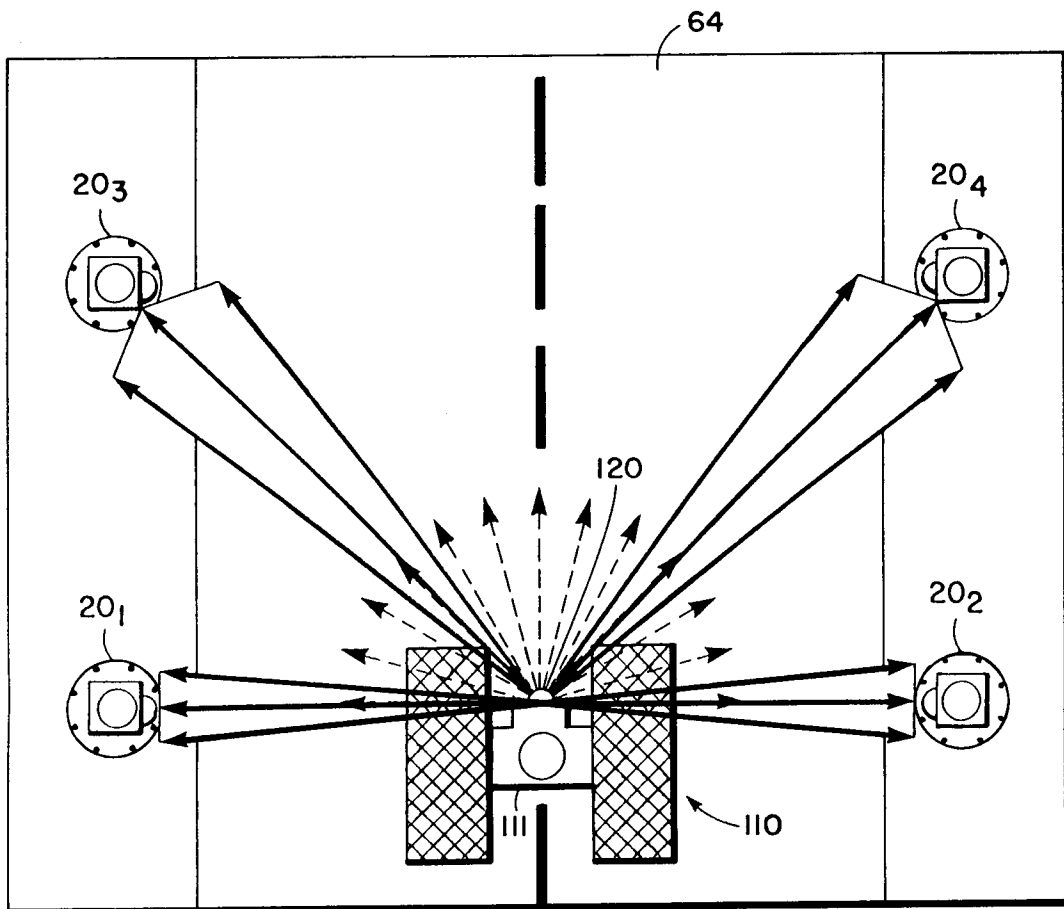

FIG. 12

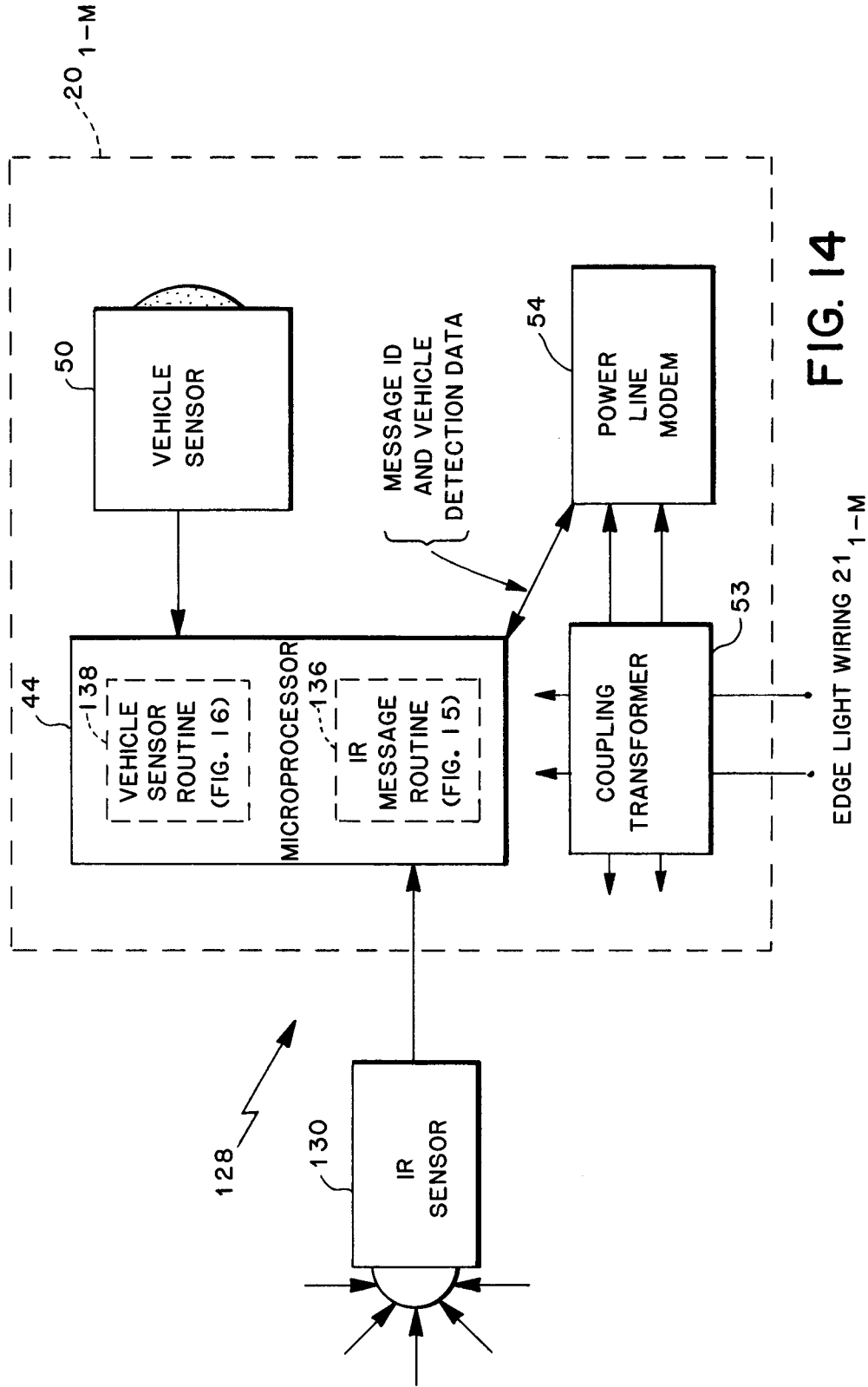

FIG. 14

EDGE LIGHT WIRING 21 1-M

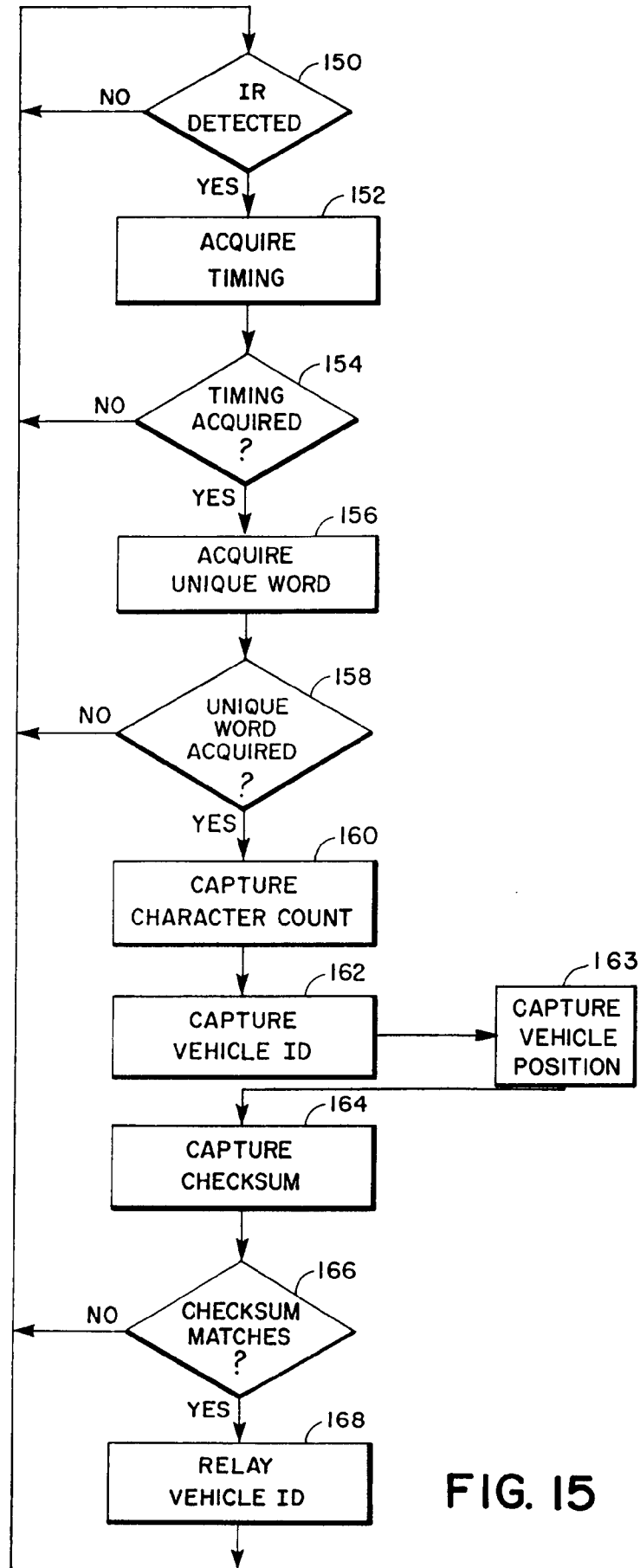

FIG. 15

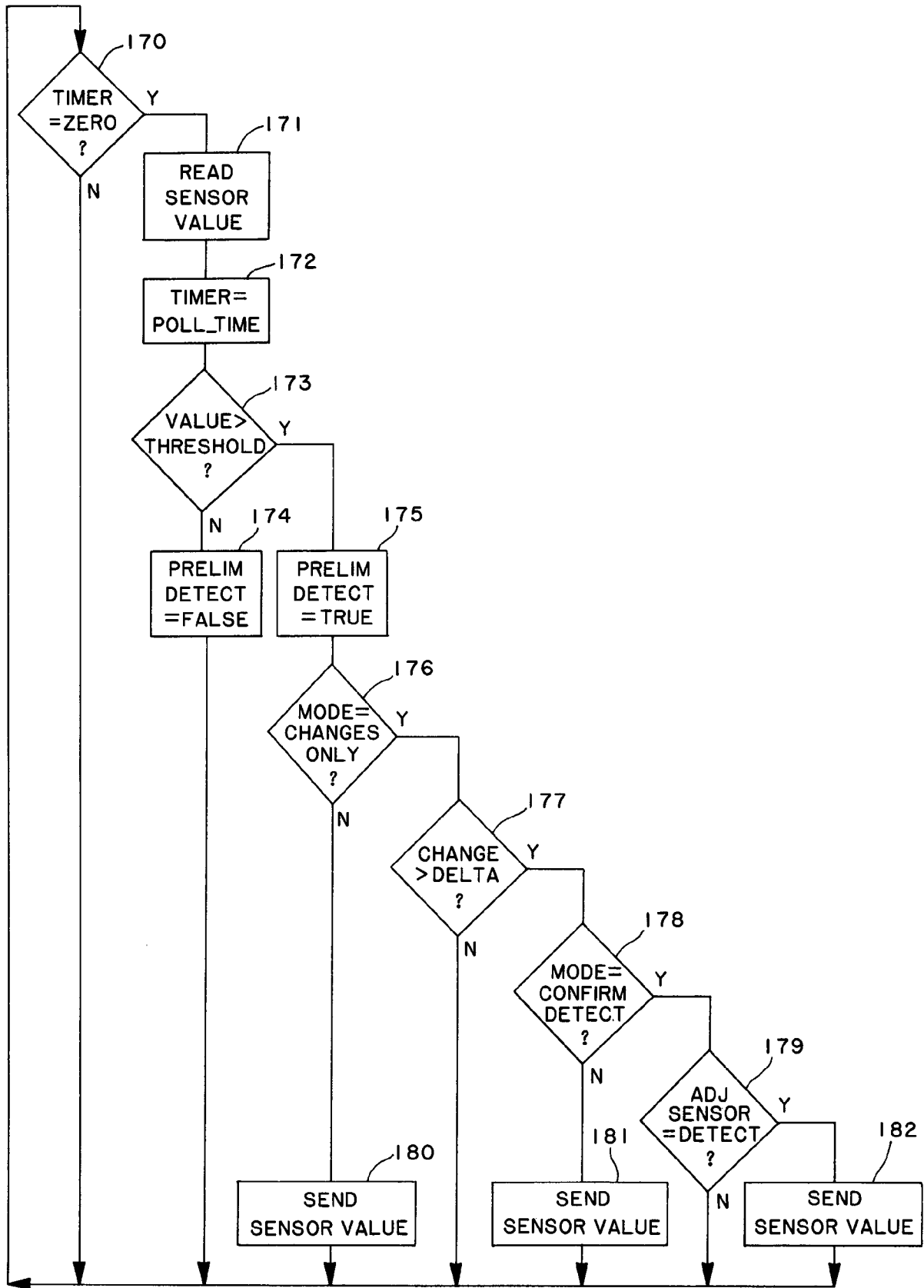

FIG. 16



European Patent Office

EUROPEAN SEARCH REPORT

Application Number
EP 94 30 1261

DOCUMENTS CONSIDERED TO BE RELEVANT			
Category	Citation of document with indication, where appropriate, of relevant passages	Relevant to claim	CLASSIFICATION OF THE APPLICATION (Int.Cl.5)
Y	US-A-3 855 571 (MASSA) * the whole document * ---	1-40	G08G5/06
Y	WO-A-90 04242 (SWEDISH AIRPORT TECHNOLOGY HB) * the whole document * ---	1-40	
Y	FR-A-2 620 551 (RINALDI) * the whole document * ---	2-5,10, 16,18, 21,22, 33,36,37	
Y	EP-A-0 209 397 (GENERAL DE INVESTIGACION Y DESARROLLO S.A.) * claims 1,5-13,23,27 * D & US-A-4 845 629 (MURGA ET AL.) ---	7-9, 13-15, 24,39,40	
Y	US-A-4 093 937 (HABINGER) * column 2, line 3 - line 33 * ---	26	
Y	US-A-3 706 969 (PAREDES) * column 3, line 18 - column 4, line 59 * * column 22, line 57 - column 23, line 28 * -----	30,31	TECHNICAL FIELDS SEARCHED (Int.Cl.5) G08G
The present search report has been drawn up for all claims			
Place of search THE HAGUE		Date of completion of the search 20 June 1994	Examiner Reekmans, M
<p>CATEGORY OF CITED DOCUMENTS</p> <p>X : particularly relevant if taken alone Y : particularly relevant if combined with another document of the same category A : technological background O : non-written disclosure P : intermediate document</p> <p>T : theory or principle underlying the invention E : earlier patent document, but published on, or after the filing date D : document cited in the application L : document cited for other reasons & : member of the same patent family, corresponding document</p>			

EPO FORM 1503 03.92 (P04C01)