

(No Model.)

H. B. KEIPER.  
DRILL.

No. 577,556.

Patented Feb. 23, 1897.

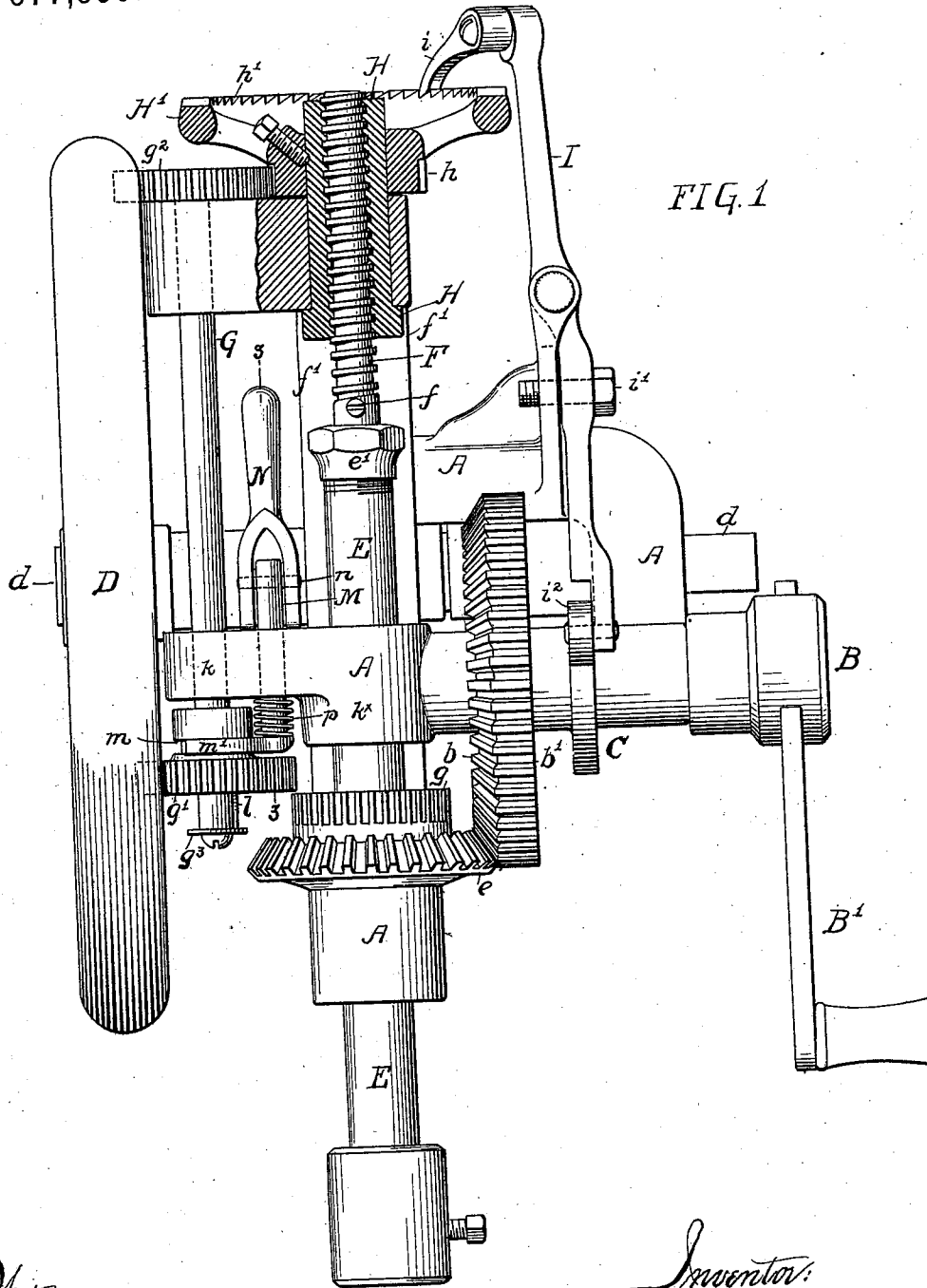

FIG. 1

Witnesses:  
*Jno E. Parker*  
*J. Henderson*

Inventor:  
*Henry B. Keiper*  
 by his Attorney,  
*James Pettie.*

H. B. KEIPER.  
DRILL.

No. 577,556.

Patented Feb. 23, 1897.

FIG. 2

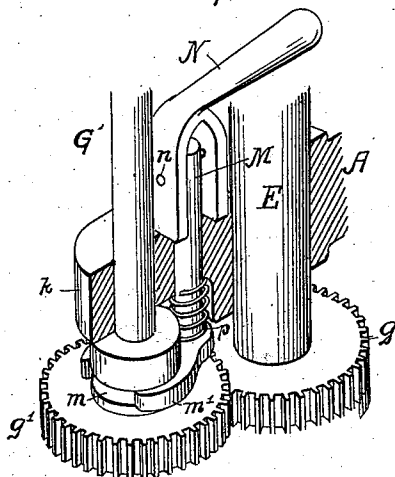
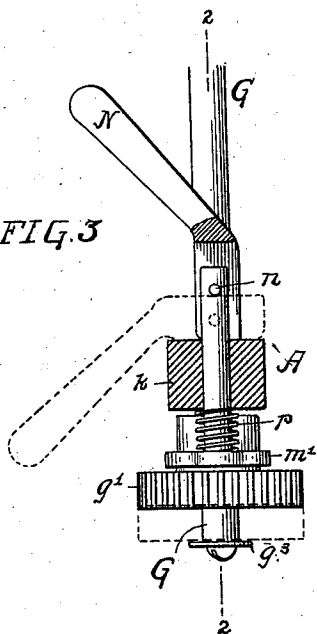

FIG. 3



Witnesses  
*J. C. Parker*  
*J. Henderson*

Inventor:  
*Henry B. Keiper,*  
 by his Attorney,  
*Home Petter.*

# UNITED STATES PATENT OFFICE.

HENRY B. KEIPER, OF LANCASTER, PENNSYLVANIA.

## DRILL.

SPECIFICATION forming part of Letters Patent No. 577,556, dated February 23, 1897.

Application filed April 23, 1894. Serial No. 508,617. (No model.)

*To all whom it may concern:*

Be it known that I, HENRY B. KEIPER, a citizen of the United States, and a resident of Lancaster, State of Pennsylvania, have invented a new and useful Improvement in Drills, of which the following is a full, clear, and exact description, reference being had to the accompanying drawings, forming part of this specification.

My invention relates to certain improvements in drills, and has for its object to provide a drill with attachments by means of which the drill-bit may be quickly elevated after the desired hole is bored in the material and without stopping the rotation of the driving-shaft, as more fully set forth herein-after.

I herein describe and illustrate a construction of apparatus embodying my invention, though it is clear that the construction may be modified without departing from the spirit of my invention.

In the accompanying drawings, Figure 1 is a front elevation, partially in section, of a drill provided with a return attachment constructed and arranged in accordance with my invention. Fig. 2 is a sectional perspective view of a portion of the same on the line 2 2, Fig. 3; and Fig. 3 is a sectional elevation on the line 3 3, Fig. 1.

Referring to the drawings, A represents a suitable bearing or framework provided with journal-bearings for the reception and support of the various operating parts. In this frame is mounted a horizontal shaft B, provided with a handled crank B' and carrying near one end a combination bevel-gear and spur-wheel  $b b'$  and a cam C. The spur-gear  $b'$  meshes with a small pinion on a horizontal shaft  $d$ , on which is mounted the balance-wheel D.

The drill-spindle E is provided with a beveled gear  $e$ , intermeshing with the bevel-gear  $b$  on the shaft B, and is also provided with a gear-wheel  $g$ , which at times when the return attachment is in operation intermeshes with a gear-wheel  $g'$ , feathered to a shaft G and capable of vertical movement thereon. The upper end of the drill-spindle is connected, as usual, by a swivel-nut  $e'$  to a threaded spindle F, which is held from rotating by a pin  $f$ , which extends through the spindle and

at the rear engages in a vertical slot provided in the upright  $f'$ , which permits the free movement of the spindle in a vertical line. The spindle F is provided with a nut H, adapted to a bearing in the frame A, and at its upper end the nut is provided with a gear-wheel  $h$  and a hand-wheel H', having ratchet-teeth  $h'$  formed on its upper surface. With these ratchet-teeth a pawl  $i$  engages, carried by an arm I, fulcrumed at  $i'$  in the framework and carrying at its lower end an antifriction-wheel  $i^2$ , normally in the path of the cam C, so that at each rotation of the latter the antifriction-wheel will be moved, causing the opposite pawl-carrying end of the lever I to effect a partial rotation of the nut H, which operates to depress the drill-spindle, the step-by-step feed continuing during the rotative movement of the drill and until the boring of the hole has been fully accomplished.

The mechanism thus far described is common to nearly all drills of this type, but the usual method of raising the drill-spindle after the hole has been bored is to reverse the movement of the driving-shaft or to turn the hand-wheel H' directly by the hand, and thus to operate upon the nut and raise the spindle, which are slow and tedious operations.

To provide for a quick return of the drill without stopping its rotative movement, and at the same time to remove the borings by revolving the drill-bit during the operation, I provide at one side of the drill-spindle a vertical shaft G, adapted to suitable bearings in the framework and carrying at its upper end a gear-wheel  $g^2$ , which is constantly in engagement with the gear-wheel  $h$ , forming the lower part of the hand-wheel H'.

The lower end of the shaft G projects for some distance below its lower bearing  $k$  and is provided with a feather  $l$  to insure the constant rotation of a gear-wheel  $g'$ , adjustably mounted upon the shaft near the lower end of the same. The hub of the gear-wheel  $g'$  is provided with an annular slot  $m$ , with which engages a forked arm  $m'$ , carried by a spindle M, adapted to a vertically-disposed guiding-opening provided in the horizontally-disposed part  $k$  of the frame A, the upper end of the spindle being secured by a transverse pin  $n$  to a handled cam N, so arranged that by turning it to the position illustrated in Fig.

1 the gear-wheel  $g'$  will be elevated to the position illustrated in said figure and will have no effect upon the movement or operation of any parts of the drill. When the hole in the material operated upon has been bored and the drill-bit is fully down, and it is desired to insure its quick return to its initial position for drilling another hole, the pawl  $i$  is thrown back out of engagement with the teeth  $h'$ , and the handled cam  $N$  is turned down, permitting the gear-wheel  $g'$  to fall to the end of the shaft  $G$  and to engage with the teeth of the wheel  $g$ , the movement of the gear being insured by a coiled spring  $p$ , surrounding that portion of the spindle  $M$  between the forked arm  $m$  and the lower surface of that portion  $k$  of the framework through which the spindle passes. Any excessive downward movement of the gear-wheel is prevented by a disk  $g^2$ , secured to the lower end of the shaft. If the cranked arm  $B'$  be rotated when these gears  $g g'$  are intermeshing, the rotations of the shaft  $B$  will be imparted to the spindle  $G$  by means of the beveled gears  $b, e, \text{ and } g$ , and as the gear-wheel  $g$  is likewise secured to the drill-spindle the rotations of the latter will be imparted to the nut  $H$  through the gear-wheel  $g'$ , the shaft  $G$ , and gear-wheels  $g^2 h$ , rotating the nut in a direction opposite to that in which it is rotated by the pawl  $i$  and quickly elevating the drill-spindle, while at the same time the drill-bit continues to revolve in the same direction as when boring and cleans the hole after the completion of the boring.

It is obvious that a device of this character may be readily applied to all drills in which a ratchet-feed is employed to depress the drill-spindle, and various modifications, as before stated, may be made in the general arrangements of the parts without departing from the spirit of my invention.

Having thus described my invention, what I claim, and desire to secure by Letters Patent, is—

In a drill, the combination with the frame, of a horizontal driving-shaft journaled therein, a combined bevel-gear and spur-wheel  $b b'$  on the driving-shaft, a horizontal counter-shaft mounted in the frame having a balance-wheel at one end and provided with a pinion meshing with the spur-wheel on the driving-shaft, the drill-spindle mounted vertically in the frame and provided with a threaded portion at its upper end, a combined bevel-gear and crown-wheel on the said spindle, the said bevel-gear meshing with the bevel-gear on the driving-shaft, a rotatable nut mounted on the threaded upper end of the drill-spindle and journaled in the frame, a combined gear-pinion and ratchet-wheel secured to the upper end of the nut, means for rotating the ratchet-wheel intermittently, a vertical shaft mounted in the frame, a pinion on the upper end of said shaft meshing with the pinion on the rotatable nut, a sliding pinion on the lower end of said shaft adapted to engage the crown-wheel on the drill-spindle and having an annular groove in its hub, a vertically-movable spindle mounted in the frame and provided at its lower end with a fork engaging the annular groove in the hub of the sliding pinion, a spring coiled around said spindle between the fork and the frame, and a cam pivoted to the upper end of the said spindle and bearing on the upper side of the frame.

In witness whereof I have hereunto set my hand this 13th day of April, A. D. 1894.

HENRY B. KEIPER.

Witnesses:

JOHN A. MERRICK,  
SAMUEL BELL.