

J. B. WITHEY.  
Carriage Spring.

No. 110,528.

Patented Dec. 27, 1870.

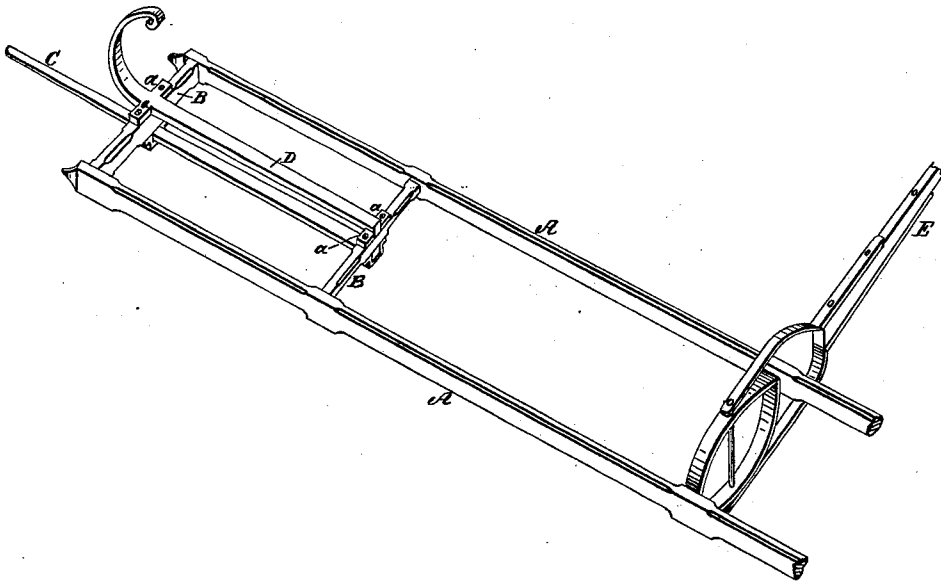

*attest.*

*Frederick Eberts.*  
*No. Stewart*

*Inventor:*

*J. B. Withey*  
*per attorney*  
*Thos. S. Sprague*

# United States Patent Office

JEROME B. WITHEY, OF DETROIT, MICHIGAN.

Letters Patent No. 110,528, dated December 27, 1870.

## IMPROVEMENT IN RUNNING-GEARS FOR CARRIAGES.

The Schedule referred to in these Letters Patent and making part of the same.

### *To whom it may concern:*

Be it known that I, JEROME B. WITHEY, of Detroit, in the county of Wayne and State of Michigan, have invented a new and useful Improvement in a Running-Gear for Carriages; and I do declare that the following is a true and accurate description thereof, reference being had to the accompanying drawing and to the letters of reference marked thereon and being a part of this specification, in which one-half of the rear part of my improved gear is shown in perspective.

The nature of this invention relates to an improved running-gear for carriages; and

It consists in the novel and peculiar construction of a pair of light wooden frames extending across the body of the vehicle, under each end, and connected by a proper reach.

To cross or bearing-bars at the ends of the frames are secured short axles, upon which the wheels rotate, or which axles may rotate in suitable bearings in the cross-bars, if preferred.

Also, in the peculiar construction and arrangement with relation to each frame of a pair of spring-supporting jacks.

In the drawing—

A are parallel bars, having mortised into them, near each end, a pair of cross or bearing-bars, B, forming a light wooden frame.

C is a short iron or steel axle, secured to the under sides of the cross-bars by proper clips, and projecting beyond the end of the frame to receive a wheel-hub.

If preferred, the wheel may be rigidly secured to the axle, and the latter arranged to rotate in suitable boxes under said cross-bars.

D is a jack, whose straight body extends from

the inner to the outer cross-bar, and is provided with the ears *a*, whereby it is secured to said bars by means of proper bolts passing through both.

The outer end of the jack is turned up and hooked to receive one end of the spring, in the usual manner.

E is the reach, which connects the frame shown to a similar one under the other end of the carriage-body.

The advantages of this gear are—

First, it is lighter and more elegant than any other.

Second, it is stronger and more durable than another of greater weight.

Third, it is more simple and less liable to get out of order.

Fourth, it will run silently, there being nothing about it that can rattle when the vehicle is in order.

Fifth, it is readily taken apart and put together for shipping or other purposes.

Sixth, the actual cost of its manufacture is at least twenty per cent. less than that of any other form of running-gear now in use.

What I claim as my invention, and desire to secure by Letters Patent, is—

1. The jack D, provided with ears *a*, as and for the purposes herein set forth.

2. The frame, consisting of the bars A B, in combination with the short axles or shafts C, jacks D, and reach E, substantially as and for the purposes set forth.

JEROME B. WITHEY.

Witnesses.

FREDERICK EBERTS,  
MARTHA STEWART.