

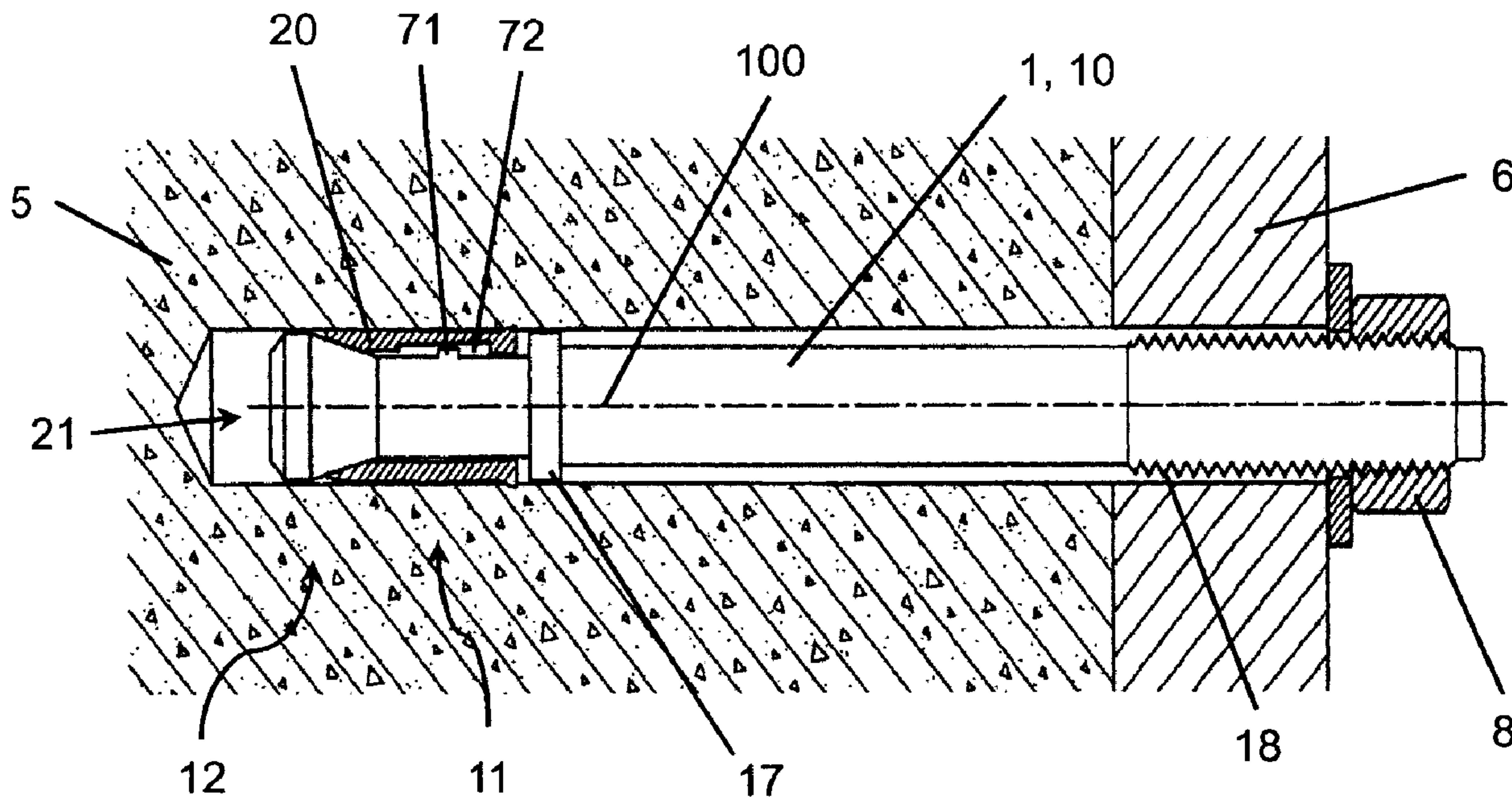

(86) **Date de dépôt PCT/PCT Filing Date:** 2014/09/02
 (87) **Date publication PCT/PCT Publication Date:** 2015/03/19
 (45) **Date de délivrance/Issue Date:** 2018/01/09
 (85) **Entrée phase nationale/National Entry:** 2016/02/25
 (86) **N° demande PCT/PCT Application No.:** EP 2014/068579
 (87) **N° publication PCT/PCT Publication No.:** 2015/036281
 (30) **Priorité/Priority:** 2013/09/16 (EP13184593.5)

(51) **Cl.Int./Int.Cl. F16B 13/06** (2006.01)
 (72) **Inventeur/Inventor:**
 SCHAEFFER, MARC, AT
 (73) **Propriétaire/Owner:**
 HILTI AKTIENGESELLSCHAFT, LI
 (74) **Agent:** ROBIC

(54) **Titre : ANCRAGE EXPANSIBLE**
 (54) **Title: EXPANSION ANCHOR**



(57) **Abrégé/Abstract:**

The invention relates to an expansion anchor (1) comprising a bolt (10) as the first element and an expansion sleeve which at least partially surrounds the bolt as the second element, the bolt having an expansion region for expansion of the expansion sleeve, one of the two elements having a groove (72) that extends in the longitudinal direction of the expansion anchor and the other element having a projection that engages with the groove at least in sections. According to the invention, the groove has a restricted portion (73) which inhibits an axial movement of the expansion sleeve relative to the bolt.

(12) NACH DEM VERTRAG ÜBER DIE INTERNATIONALE ZUSAMMENARBEIT AUF DEM GEBIET DES PATENTWESENS (PCT) VERÖFFENTLICHTE INTERNATIONALE ANMELDUNG

(19) Weltorganisation für geistiges

Eigentum

Internationales Büro

(43) Internationales

Veröffentlichungsdatum

19. März 2015 (19.03.2015)



(10) Internationale Veröffentlichungsnummer

WO 2015/036281 A1

(51) Internationale Patentklassifikation:

F16B 13/06 (2006.01)

(21) Internationales Aktenzeichen: PCT/EP2014/068579

(22) Internationales Anmeldedatum:

2. September 2014 (02.09.2014)

(25) Einreichungssprache: Deutsch

(26) Veröffentlichungssprache: Deutsch

(30) Angaben zur Priorität:

13184593.5 16. September 2013 (16.09.2013) EP

(71) Anmelder: HILTI AKTIENGESELLSCHAFT [LI/LI];
Feldkircherstr. 100, CH-9494 Schaan (LI).(72) Erfinder: SCHAEFFER, Marc; Breiter Weg 22, A-6800
Feldkirch-Nofels (AT).(81) Bestimmungsstaaten (soweit nicht anders angegeben, für
jede verfügbare nationale Schutzrechtsart): AE, AG, AL,
AM, AO, AT, AU, AZ, BA, BB, BG, BH, BN, BR, BW,
BY, BZ, CA, CH, CL, CN, CO, CR, CU, CZ, DE, DK,
DM, DO, DZ, EC, EE, EG, ES, FI, GB, GD, GE, GH, GM,GT, HN, HR, HU, ID, IL, IN, IR, IS, JP, KE, KG, KN, KP,
KR, KZ, LA, LC, LK, LR, LS, LT, LU, LY, MA, MD,
ME, MG, MK, MN, MW, MX, MY, MZ, NA, NG, NI,
NO, NZ, OM, PA, PE, PG, PH, PL, PT, QA, RO, RS, RU,
RW, SA, SC, SD, SE, SG, SK, SL, SM, ST, SV, SY, TH,
TJ, TM, TN, TR, TT, TZ, UA, UG, US, UZ, VC, VN, ZA,
ZM, ZW.(84) Bestimmungsstaaten (soweit nicht anders angegeben, für
jede verfügbare regionale Schutzrechtsart): ARIPO (BW,
GH, GM, KE, LR, LS, MW, MZ, NA, RW, SD, SL, ST,
SZ, TZ, UG, ZM, ZW), eurasisches (AM, AZ, BY, KG,
KZ, RU, TJ, TM), europäisches (AL, AT, BE, BG, CH,
CY, CZ, DE, DK, EE, ES, FI, FR, GB, GR, HR, HU, IE,
IS, IT, LT, LU, LV, MC, MK, MT, NL, NO, PL, PT, RO,
RS, SE, SI, SK, SM, TR), OAPI (BF, BJ, CF, CG, CI, CM,
GA, GN, GQ, GW, KM, ML, MR, NE, SN, TD, TG).

Veröffentlicht:

— mit internationalem Recherchenbericht (Artikel 21 Absatz
3)

(54) Title: EXPANSION ANCHOR

(54) Bezeichnung : SPREIZANKER

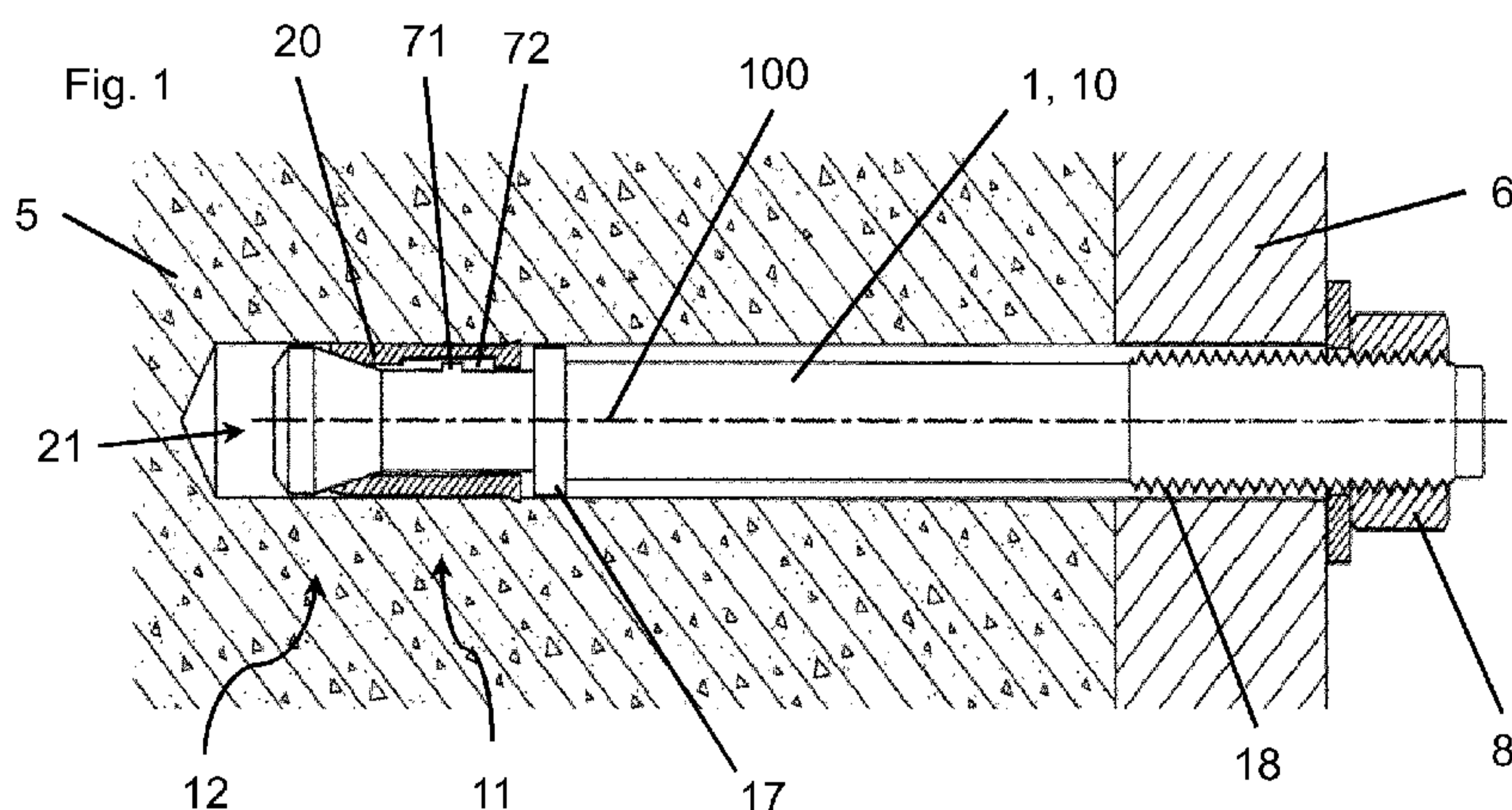

(57) Abstract: The invention relates to an expansion anchor (1) comprising a bolt (10) as the first element and an expansion sleeve which at least partially surrounds the bolt as the second element, the bolt having an expansion region for expansion of the expansion sleeve, one of the two elements having a groove (72) that extends in the longitudinal direction of the expansion anchor and the other element having a projection that engages with the groove at least in sections. According to the invention, the groove has a restricted portion (73) which inhibits an axial movement of the expansion sleeve relative to the bolt.

(57) Zusammenfassung: Die Erfindung betrifft einen Spreizanker (1) mit einem Bolzen (10) als erstes Element und mit einer Spreizhülse, welche den Bolzen zumindest teilweise umgibt, als zweites Element, wobei der Bolzen einen Spreizbereich zum Aufspreizen der Spreizhülse aufweist, wobei eines der beiden Elemente eine in Längsrichtung des Spreizankers verlaufende Nut (72) und das andere Element einen Vorsprung aufweist, der zumindest bereichsweise in die Nut eingreift. Erfindungsgemäss ist vorgesehen, dass die Nut eine Verengung (73) aufweist, die eine Axialbewegung der Spreizhülse relativ zum Bolzen hemmt.



WO 2015/036281 A1

Hilti AG in Schaan

Principality of Liechtenstein

Expansion anchor

The invention relates to an expansion anchor. Such an expansion anchor is designed with a bolt as a first element and with an expansion sleeve, which at least partially surrounds the bolt, as a second element, wherein the bolt has an expansion region for spreading apart the expansion sleeve, wherein one of the two elements, particularly on an external peripheral surface or internal peripheral surface, has a groove running in the longitudinal direction of the expansion anchor and the other element has a projection, which engages at least sectionally in the groove.

Expansion anchors are known from DE 101 08 844 A1, for example. They are used in a borehole in a substrate, e.g., in a wall or a ceiling of a construction unit. By pulling the expansion region of the bolt into the expansion sleeve, the latter is radially widened and the expansion anchor is anchored in the substrate.

EP 0 515 916 A2 and DE 2 256 8 22 A1 describe expansion anchors, in which an anti-rotation means of the expansion sleeve on the bolt is prevented by a groove guide.

The object of the invention is to provide an expansion anchor, which achieves particularly good load values, while having low production costs and high reliability.

The object is achieved according to the invention by an expansion anchor with the features of claim 1. Preferred embodiments are indicated in the dependent claims.

The expansion anchor according to the invention is characterized in that the groove presents a local narrowing, creating a bottleneck effect, and said local narrowing inhibits an axial movement of the expansion sleeve relative to the bolt.

According to the invention, the groove has a narrowing that inhibits an axial movement of the projection relative to the groove, and thus an axial movement of the expansion sleeve relative to the bolt, preferably an axial movement of the expansion sleeve relative to the bolt into the expansion region.

According to the invention, it is thus provided that the cross-section of the groove along the bolt varies, so that the projection engaging into the groove rubs against the groove at varying levels of intensity, depending on the position of the expansion sleeve relative to the bolt, which in turn results in varying forces being required, depending on the position of the expansion sleeve relative to the bolt, to displace the expansion sleeve on the bolt. According to the invention, and in a particularly simple and cost-effective manner, an additional parameter is provided with which one can control the anchoring process of the anchor. This in turn allows one to resolve conflicts that may exist under certain circumstances in conventional expansion anchors. For example, in regard to conventional anchors, it may be desirable to have a relatively stiff design of the sleeve on the one hand, e.g., to counteract the possibility of a premature complete pull-through of the bolt through the sleeve when the anchor is set; however, simultaneously, a relatively malleable design of the sleeve may be desired so that it can adapt particularly well to the substrate for example, and thereby offer particularly good load transfer values. According to the invention, the pull-through behavior can now also be controlled by means of the narrowing of the groove, so that the sleeve can be selected to be malleable in regard to load transfer values, without having to hereby consider the pull-through behavior to a significant degree. In this way, a particularly reliable anchor can be obtained according to the invention.

The narrowing exists for practical purposes at least in the peripheral direction of the bolt and/or the expansion sleeve, i.e., seen in the peripheral direction, the groove at the narrowing is preferably narrower than the width of the projection. Preferably, the groove outside the narrowing is cross-sectionally greater than the projection in such a manner that the projection there can move in an essentially non-frictional manner in the groove. In particular, the groove outside of the narrowing, as seen in the peripheral direction of the bolt and/or the expansion sleeve, may be wider than the projection. This can also have production-related advantages. In particular, in this case the sleeve may be rolled in an especially load-free manner, and thus in an especially simple manner, on the bolt.

The bolt may have a neck region for receiving the expansion sleeve prior to expansion, in which the bolt has preferably, at least sectionally, an at least almost constant cross-section in the longitudinal direction. In the expansion region, the bolt widens towards its tip, i.e., as the distance increases from the neck region. The groove and/or the projection run preferably parallel to the longitudinal axis of the bolt and/or expansion anchor. To the extent that the radial direction and the longitudinal direction are mentioned here, this shall refer in particular to the longitudinal axis of the bolt and/or the anchor,

which may be in particular the symmetrical and/or central axis of the bolt and the anchor, respectively.

The expansion sleeve and/or the bolt consist preferably of a metal material. Preferably, the bolt has on its end region opposite the expansion region exterior threads for a nut. In particular, on the bolt, there may be designed a stop, for example, an annular shoulder, which limits a displacement of the sleeve away from the expansion region. However, the expansion sleeve, which may also be designed in a multi-part manner, may also extend to the exterior threads of the bolt. The expansion region is provided according to the invention for spreading out the expansion sleeve, i.e., for the radial widening of the expansion sleeve.

The projection engaging into the groove may also form an anti-rotation means, which inhibits a rotation of the expansion sleeve relative to the bolt about the longitudinal axis of the bolt. Fundamentally, the projection could have discontinuities. However, the projection is preferably continuous.

It is especially preferred that the groove arranged on the bolt, or the projection arranged on the bolt, runs at least partially outside of the expansion region. This design may take into account among other things that the tensile forces of the set expansion anchor are introduced primarily in the expansion region in the bolt. By the groove or the projection running at least partially, preferably entirely, outside the expansion region, one avoids impairing the force transmission. Preferably, the groove, or the projection, on the bolt runs at least sectionally in the neck region, i.e., especially in the region between the expansion region and the stop for the expansion sleeve.

Furthermore, it is preferred that the projection is arranged on the bolt and the groove is arranged on the expansion sleeve. This may be especially advantageous in a production-related manner. For example, the groove may be rolled in. The projection may be formed during a rolling or compressing process.

Alternatively, it may be provided that the projection is arranged on the expansion sleeve and the groove is arranged on the bolt. In this context, it may be especially advantageous that the wall thickness of the expansion sleeve is increased locally by the projection. On the projection, a particularly large expansion can hereby be achieved, without the neck region of the bolt, in which the projection is arranged prior to

expansion, being significantly weakened. A local wall thickness increase may refer especially to the wall thickness being larger at the projection than in its periphery.

It may also be provided that the expansion anchor has a plurality of grooves running in the longitudinal direction of the expansion anchor and a plurality of respective corresponding projections, wherein at least part of the grooves each have a narrowing, which inhibits an axial movement of the corresponding projection and thus an axial movement of the expansion sleeve relative to the bolt, particularly an axial movement of the expansion sleeve relative to the bolt into the expansion region. In addition, all grooves may have such a narrowing. For example, all grooves may be provided on one of the elements and all projections may be provided on the other element. However, a mixed arrangement may also be provided, in which one of the elements has part of the grooves and one has part of the projections.

Depending on the desired force progression, it may be advantageous that the narrowing is provided at one end of the groove or in a middle region of the groove.

Preferably, the projection is a cross-piece, which extends in the longitudinal direction of the expansion anchor, and runs in particular parallel to the longitudinal direction of the expansion anchor. The displacement behavior of the expansion sleeve can thereby be controlled in a more exact manner.

The invention is subsequently explained in further detail by means of preferred embodiments, which are schematically illustrated in the enclosed drawings, wherein individual features of the subsequently depicted embodiments may be executed within the scope of the invention basically in an individual manner or in any combination. Schematically depicted in the drawings are:

Fig. 1: A partial longitudinally cut perspective of an expansion anchor according to the invention placed in a concrete substrate;

Fig. 2: A plan view of the exterior side of the bolt of the anchor from Fig. 1 in the neck region;

Fig. 3: A plan view of the interior side of the expansion sleeve of the anchor from Fig. 1; and

Fig. 4: A plan view of the interior side of another embodiment of an expansion sleeve for the anchor from Fig. 1.

Figs. 1 to 3 depict an embodiment of an expansion anchor 1 according to the invention. As Fig. 1 in particular shows, expansion anchor 1 has a bolt 10 and an expansion sleeve 20, which surrounds bolt 10. Bolt 10 has a neck region 11 with a constant cross-section, and connecting to neck region 11 in the front end region of bolt 10, there is an expansion region 12 for expansion sleeve 20, in which bolt 10 widens starting at the neck region 11 toward its front end. On the side, facing away from expansion region 12, of neck region 11, bolt 10 has a stop designed as an annular shoulder, for example, for expansion sleeve 20. On its rear end region opposite expansion region 12, bolt 10 is furnished with external threads 18 for bolt 8.

As one can see especially in Fig. 3, expansion sleeve 20 has expansion slits 24, which extend from the front face 21 of expansion sleeve 20. These expansion slits 24 facilitate the radial widening of expansion sleeve 20 through expansion region 12 of bolt 10. Expansion sleeve 20 can be produced by rolling on a sheet metal blank.

When setting expansion anchor 1, bolt 10 with expansion region 12 is pushed forward in the direction of longitudinal axis 100 of bolt 10 into a borehole in substrate 5 from Fig. 1. Due to stop 17, expansion sleeve 20 is also thereby inserted into the borehole. Then, bolt 10, is pulled back out a little bit from the borehole, for example by tightening bolt 8. Due to its friction with the borehole wall, expansion sleeve 20 remains and a displacement of bolt 10 occurs relative to expansion sleeve 20, in which expansion region 12 of bolt 10 penetrates always deeper into expansion sleeve 20 in such a manner that expansion sleeve 20 is radially widened by expansion region 12 of bolt 10 and is pressed against the wall of the borehole. By means of this mechanism, expansion anchor 1 is fixed in substrate 5. The set state of expansion anchor 1, in which it is fixed in substrate 5, is depicted in Fig. 1. By means of nut 8, an add-on part 6 can be fixed to substrate 5.

As Figs. 1 and 2 show, bolt 10 has in its neck region 11 a projection 71, which projects radially outward from bolt 10. As Figs. 1 and 3 show, expansion sleeve 20 has a groove 72 corresponding to this projection 71, which extends in the direction of the longitudinal axis 100 of bolt 10, preferably parallel to longitudinal axis 100, and in which projection 71 is received. Groove 72 of Fig. 3 has two regions, in which groove 72 is cross-sectionally larger than projection 71, in in which projection 71 can move in an

essentially friction-free manner. Between these two regions, groove 72 has a narrowing 73. Projection 71 can only pass through this narrowing 73 by increasing the application of force. Narrowing 73 thus inhibits projection 71 from passing through, i.e., it inhibits the axial movement of expansion sleeve 20 relative to bolt 10 at a predetermined axial position. In particular, narrowing 73 can thereby counteract bolt 10 from pulling through expansion sleeve 20 in an undesired manner.

As Fig. 2 shows, projection 71 may be designed as an elongated cross-piece extending toward longitudinal axis 100 of bolt 10, preferably parallel to longitudinal axis 100.

Another embodiment of an expansion sleeve is depicted in Fig. 4. According to the embodiment of Fig. 4, narrowing 73 is located at the end of groove 72, while according to Fig. 3, it was provided in a middle region of groove 72. In particular, narrowing 73 of Fig. 4 is arranged on that end of groove 72, which faces away from expansion region 12 of bolt 10 and faces threads 18.

CLAIMS

1. Expansion anchor (1)

with a bolt (10) as a first element and with an expansion sleeve (20), which surrounds the bolt (10) at least partially, as a second element, wherein the bolt (10) has an expansion region (12) for expanding expansion sleeve (20),

wherein one of the two elements has a groove (72) running in the longitudinal direction of the expansion anchor (1) and the other element has a projection (71), which engages at least sectionally into the groove (72),

wherein

the groove (72) presents a local narrowing, creating a bottleneck effect, said local narrowing (73) inhibits an axial movement of the expansion sleeve (20) relative to the bolt (10).

2. Expansion anchor (1) according to claim 1, wherein the groove (72) is wider outside of the narrowing (73), when seen in the peripheral direction of the bolt (10) and/or the expansion sleeve (20), than the projection (71).

3. Expansion anchor (1) according to claim 1 or 2, wherein the groove (72) arranged on the bolt (10) or the projection (71) arranged on the bolt (10) runs at least partially outside of the expansion region (12).

4. Expansion anchor (1) according to any one of the claims 1 to 3, wherein the projection (71) is arranged on the bolt (10) and the groove (72) is arranged on the expansion sleeve (20).

5. Expansion anchor (1) according to any one of the claims 1 to 3, wherein the projection (71) is arranged on the expansion sleeve (20) and the groove (72) is arranged on the bolt (10),
wherein the wall thickness of the expansion sleeve (20) is locally increased by the projection (71).

6. Expansion anchor (1) according to any one of claims 1 to 5, wherein the expansion anchor (1) has a plurality of grooves (72) running in the longitudinal direction of the

expansion anchor (1) and a plurality of respectively corresponding projections (71), wherein at least a portion of the grooves (72) each have a narrowing (73), which inhibits an axial movement of the expansion sleeve (20) relative to the bolt (10).

7. Expansion anchor (1) according to any one of claims 1 to 6, wherein the narrowing (73) is provided on one end of the groove (72), or that the narrowing (73) is provided in a middle region of the groove (72).
8. Expansion anchor (1) according to any one of claims 1 to 7, wherein the projection (71) is a cross-piece which extends in the longitudinal direction of the expansion anchor (1).
9. Expansion anchor (1) according to any one of claims 1 to 8, wherein the expansion sleeve has an outer surface and an inner surface, and the bolt has a neck region (11), the inner surface of the expansion sleeve facing and surrounding the neck region of the bolt, and wherein the groove (72) is provided on the inner side of the expansion sleeve (20) without opening of its outer surface.
10. Expansion anchor (1) according to any one of claims 1 to 9, wherein the groove (72) comprises first and second regions, the first region being wider than the second region, the local narrowing forming the second region; and when the projection is in the first region, the projection can move in a friction free manner, and when the projection is in the second region, the projection is frictionally engaged with sidewalls of the projection.

