



US00D749498S

(12) **United States Design Patent**  
**Ropars**

(10) **Patent No.:** **US D749,498 S**

(45) **Date of Patent:** **\*\* Feb. 16, 2016**

(54) **SURFACE DESIGN FOR A PNEUMATIC TIRE**

(71) Applicant: **Olivier Ropars**, Clermont-Ferrand (FR)

(72) Inventor: **Olivier Ropars**, Clermont-Ferrand (FR)

(73) Assignees: **COMPANGNIE GENERALE DES  
ETABLISSEMENTS MICHELIN  
(FR); MICHELIN RECHERCHE ET  
TECHNIQUE S.A. (CH)**

(\*\*) Term: **14 Years**

(21) Appl. No.: **29/483,968**

(22) Filed: **Mar. 5, 2014**

(30) **Foreign Application Priority Data**

Sep. 6, 2013 (EM) ..... 002304121-0001

(51) **LOC (10) CL.** ..... **12-05**

(52) **U.S. CL.**  
USPC ..... **D12/605; D5/30**

(58) **Field of Classification Search**

USPC ..... D12/504, 604, 605; D5/30, 46, 53, 56,  
D5/59, 60, 61, 62; D7/588, 396.4, 396.5;  
D24/124, 125, 126; D25/100, 101,  
D25/109, 138; D2/952  
CPC ..... B60C 13/00; B60C 13/001; B60C 13/02;  
B60C 1/0025; D04H 11/00; D04H 11/04;  
D04H 11/08

See application file for complete search history.

(56) **References Cited**

**U.S. PATENT DOCUMENTS**

D44,854 S \* 11/1913 Morris ..... D12/504  
D44,855 S \* 11/1913 Morris ..... D12/504  
D46,439 S \* 9/1914 Marshall ..... D12/504  
D47,892 S \* 9/1915 Hauvette-Michelin ..... D12/504  
D47,963 S \* 10/1915 Mooney ..... D12/504

D48,690 S \* 3/1916 McGraw ..... D12/504  
D58,018 S \* 5/1921 Campbell ..... D12/504  
D63,022 S \* 9/1923 Black ..... D12/504  
D99,981 S \* 6/1936 Anderson ..... D12/605  
D104,558 S \* 5/1937 Carter ..... D5/61  
D154,950 S \* 8/1949 Ortner ..... D5/60  
D388,041 S \* 12/1997 Cross ..... D12/605  
D461,643 S \* 8/2002 Missoni ..... D5/59  
D472,391 S \* 4/2003 Romero Femenia ..... D5/46  
D532,613 S \* 11/2006 Wu ..... D5/53  
D568,806 S \* 5/2008 Dixon et al. .... D12/605  
D606,013 S \* 12/2009 Reese et al. .... D12/605  
D631,262 S \* 1/2011 Evans ..... D5/56  
D674,745 S \* 1/2013 Miyazaki ..... D12/605

\* cited by examiner

*Primary Examiner* — Cynthia M Chin

(74) *Attorney, Agent, or Firm* — Dickinson Wright PLLC

(57) **CLAIM**

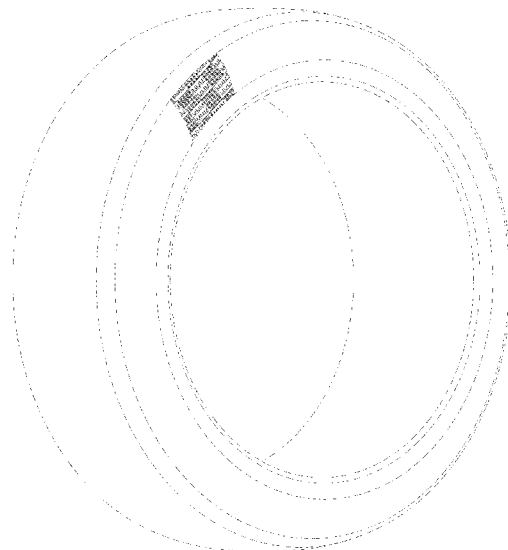
The ornamental design for a surface design for a pneumatic tire, as shown and described.

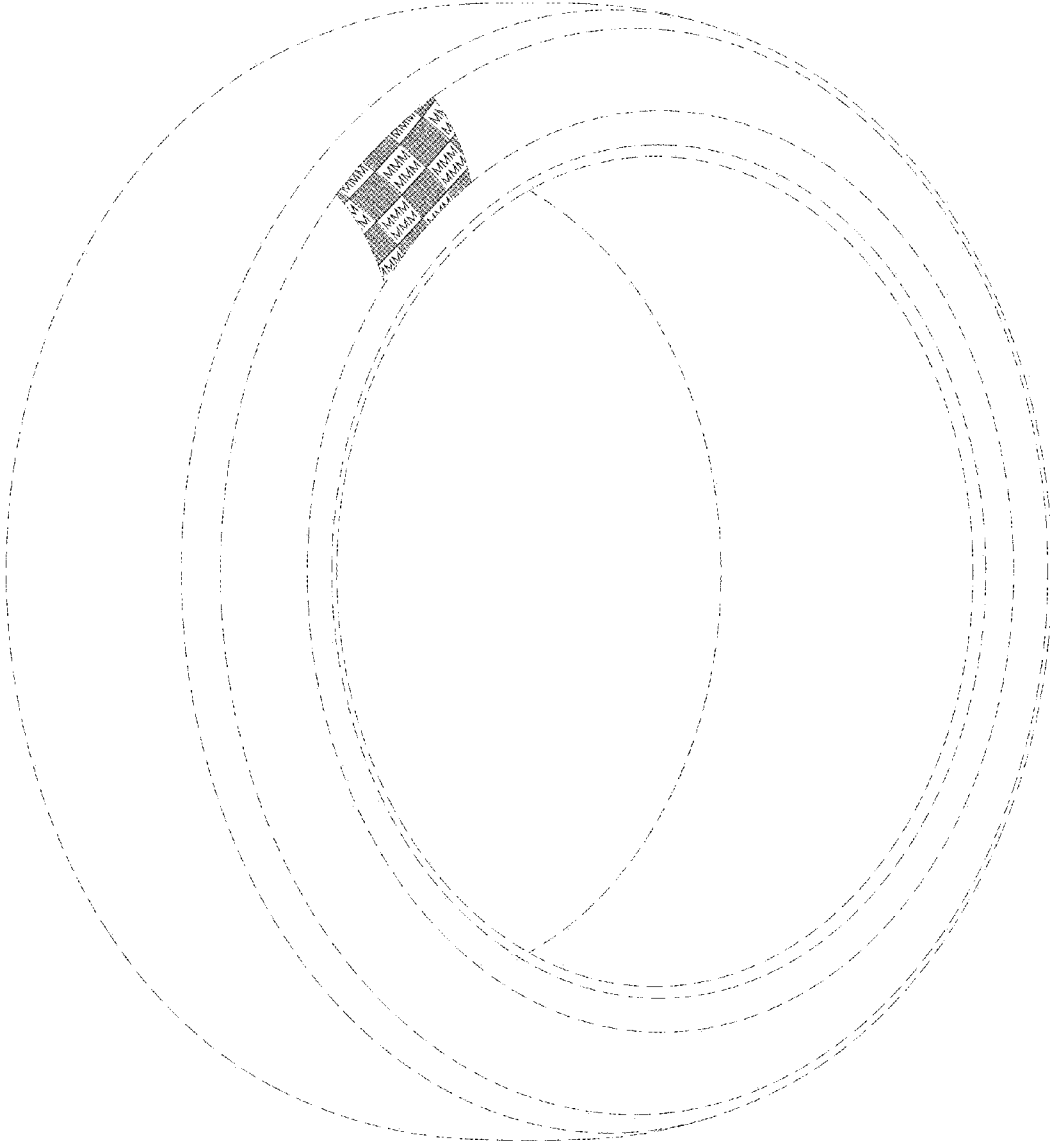
**DESCRIPTION**

FIG. 1 is a perspective view of a pneumatic tire with the ornamental surface design shown on the sidewall thereof; FIG. 2 is a side elevational view of a pneumatic tire with the ornamental surface design shown on the sidewall thereof, the opposite view being the mirror-image thereof; FIG. 3 is a front elevational view of a pneumatic tire with the ornamental surface design on the sidewall thereof, the opposite view being the mirror-image thereof; and, FIG. 4 is an enlarged, partial view of FIG. 1, detailing the ornamental surface design thereof.

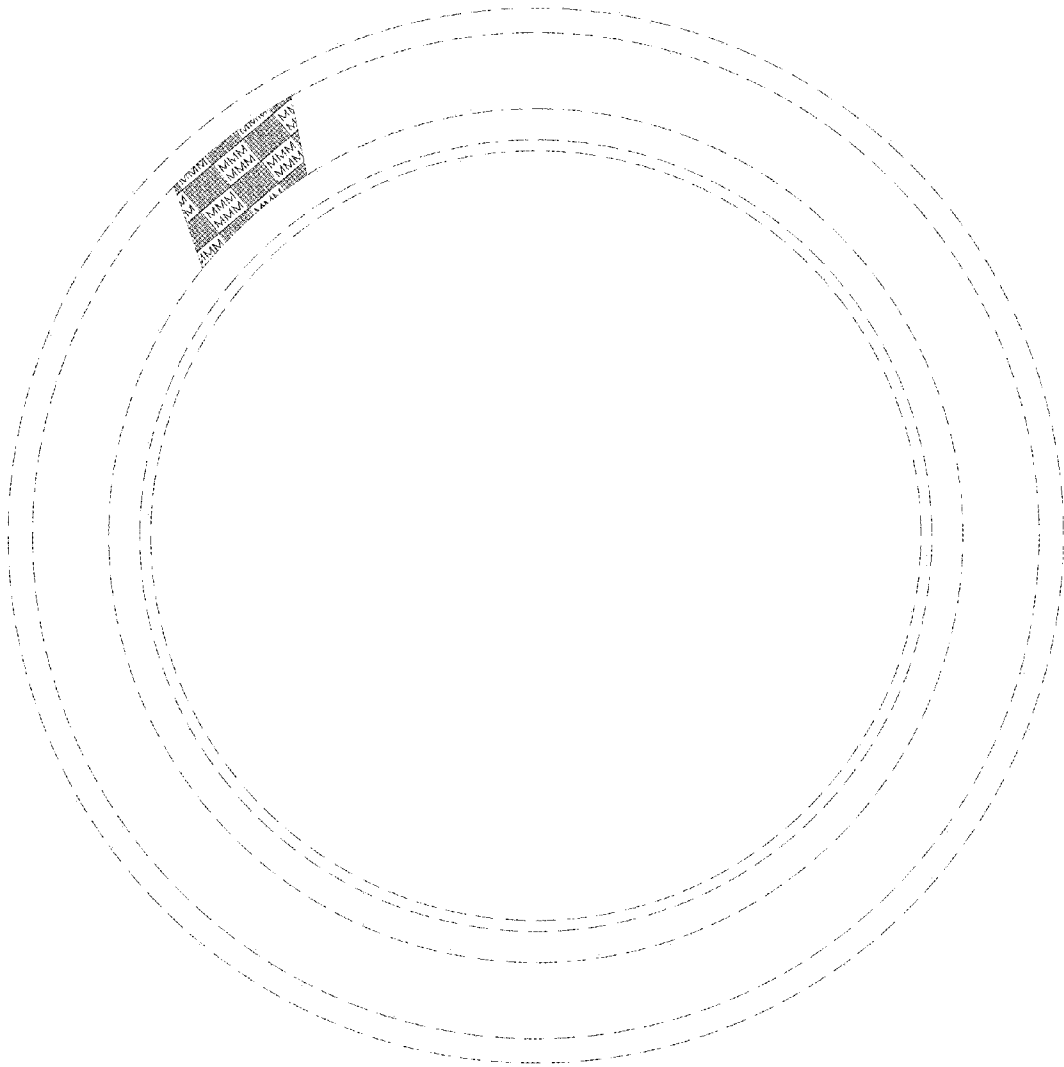
In the drawings, the broken lines depict environmental subject matter that forms no part of the claimed design. The dash-dot lines represent the boundary of the claimed surface design. The design is understood to repeat uniformly over the annular area of the tire sidewall.

**1 Claim, 4 Drawing Sheets**

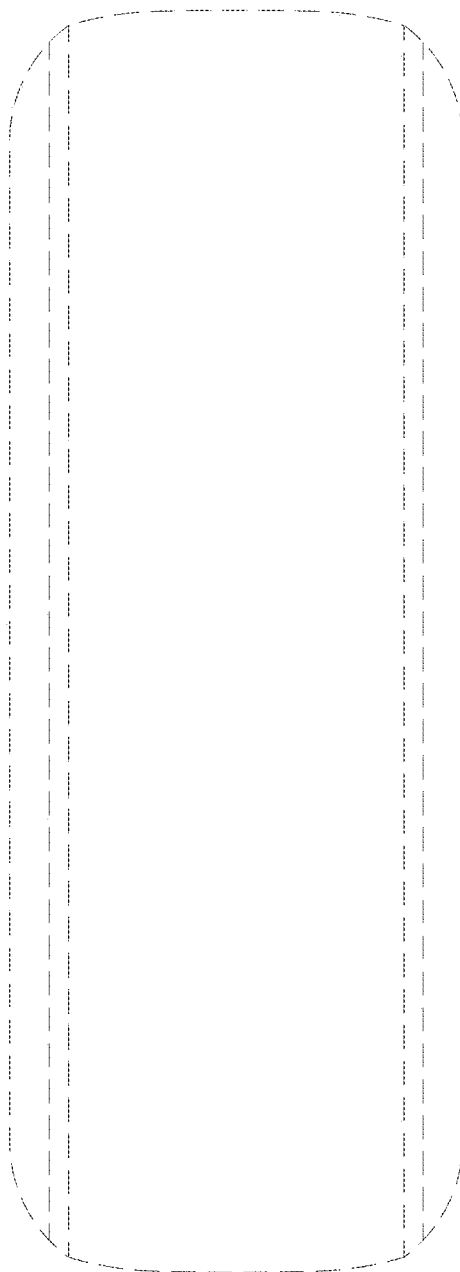




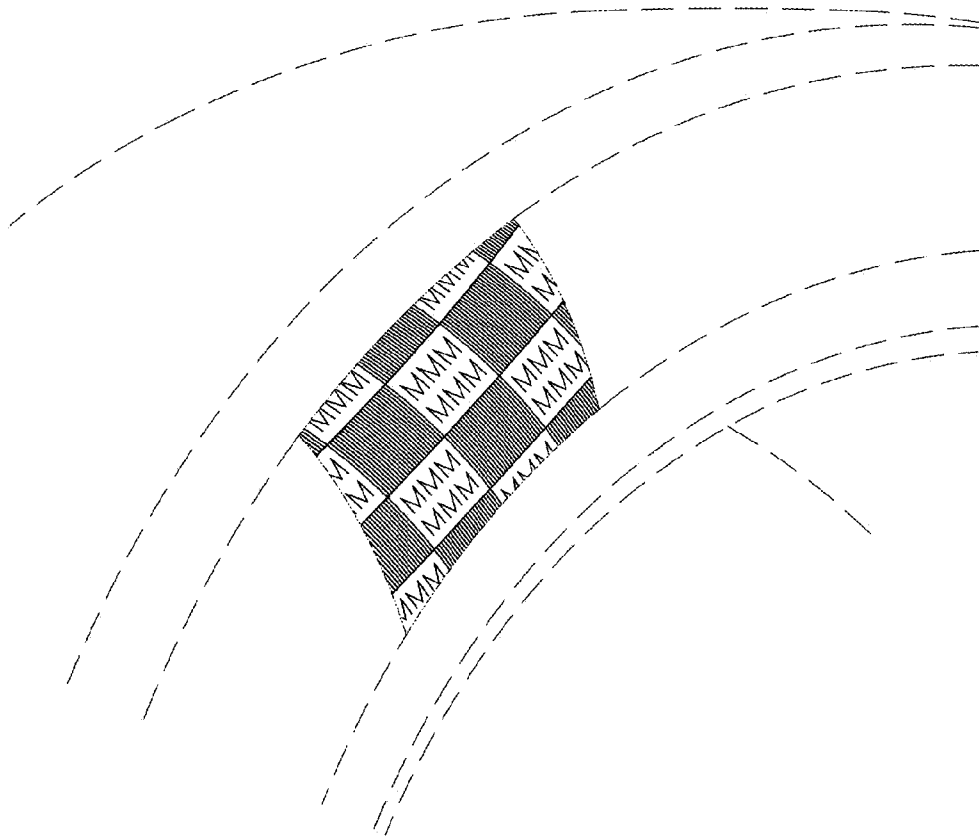
**FIG. 1**



**FIG. 2**



**FIG. 3**



**FIG. 4**