



INTERNATIONAL APPLICATION PUBLISHED UNDER THE PATENT COOPERATION TREATY (PCT)

<p>(51) International Patent Classification³ : A62B 7/10</p>	<p>A1</p>	<p>(11) International Publication Number: WO 83/ 00632 (43) International Publication Date: 3 March 1983 (03.03.83)</p>
<p>(21) International Application Number: PCT/US82/01164 (22) International Filing Date: 26 August 1982 (26.08.82) (31) Priority Application Number: 297,010 (32) Priority Date: 27 August 1981 (27.08.81) (33) Priority Country: US</p> <p>(71)(72) Applicants and Inventors: VAUGHAN, Kenneth, V. [GB/US]; 40 Concord Court, Mt. Airy, MD 21771 (US). WIGGINS, James, R. [US/US]; 379 West Side Drive, Apt. 301, Gaithersburg, MD 20878 (US).</p> <p>(81) Designated States: AT (European patent), AU, BE (European patent), BR, CF (OAPI patent), CG (OAPI patent), CH (European patent), CM (OAPI patent), DE, DE (European patent), DK, FR (European patent), GA (OAPI patent), GB, GB (European patent), JP, LU (European patent), NL (European patent), SE, SE (European patent), SN (OAPI patent), SU, TD (OAPI patent), TG (OAPI patent).</p>		<p>Published <i>With international search report. Before the expiration of the time limit for amending the claims and to be republished in the event of the receipt of amendments.</i></p>
<p>(54) Title: IMPROVEMENT IN RESPIRATORY DEVICES</p>		

(57) Abstract

Respirators, particularly powered respirators, used to protect the wearer from contaminated atmospheres. Various types of protective devices are currently available. The negative pressure respirators available are generally uncomfortable and provide low protection because of the difficulties of sealing a large variety of face sizes. Other positive pressure types are generally heavy, rigid and cumbersome being constructed around bulky and heavy helmets and hoods that may require trailing hoses. The invention is a powered filtering respirator comprising of a non-rigid headcover (1), an electric motor and fan unit (10), and at least one filter (14). The electric motor may be connected to an alternating current source or may be powered by a battery. The invention has wide applicability wherever there is a risk of exposure to health and lung damaging particulates or gases during occupations or hobbies, or for allergy sufferers exposed to pollen and spores.

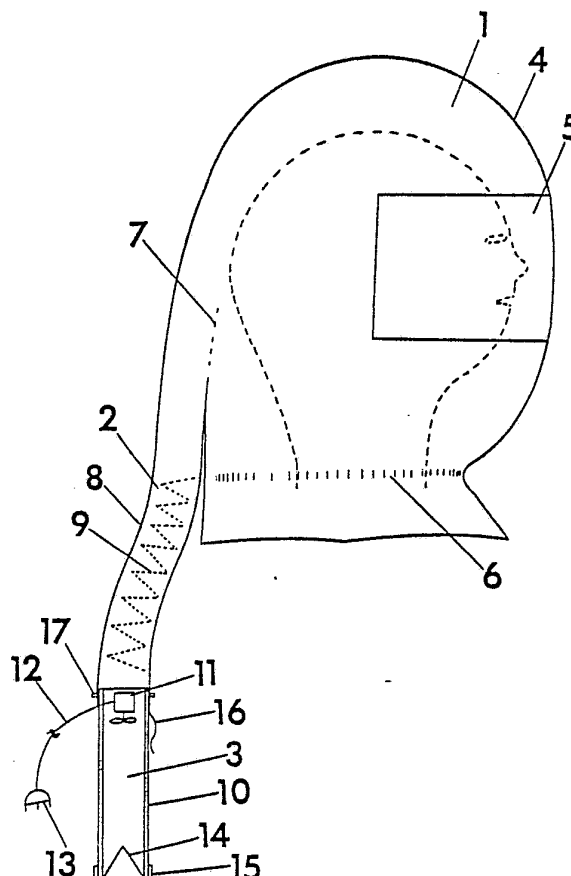

FOR THE PURPOSES OF INFORMATION ONLY

Codes used to identify States party to the PCT on the front pages of pamphlets publishing international applications under the PCT.

AT	Austria	KP	Democratic People's Republic of Korea
AU	Australia	LI	Liechtenstein
BE	Belgium	LK	Sri Lanka
BR	Brazil	LU	Luxembourg
CF	Central African Republic	MC	Monaco
CG	Congo	MG	Madagascar
CH	Switzerland	MW	Malawi
CM	Cameroon	NL	Netherlands
DE	Germany, Federal Republic of	NO	Norway
DK	Denmark	RO	Romania
FI	Finland	SE	Sweden
FR	France	SN	Senegal
GA	Gabon	SU	Soviet Union
GB	United Kingdom	TD	Chad
HU	Hungary	TG	Togo
JP	Japan	US	United States of America

1

DESCRIPTION

IMPROVEMENT IN RESPIRATORY DEVICES

Technical Field

The invention relates to respirators to be used by individuals to prevent or limit the breathing of contaminated atmospheres. More particularly, the invention relates to the use of a power source to activate a blower which moves the contaminated atmosphere through a filter or filters and provides a flow of purified atmosphere for the wearer to breath as a positive pressure.

Existing positive pressure devices are generally heavy, rigid and cumbersome, being designed as helmets or hoods. These are generally expensive. Existing negative pressure respirators are uncomfortable, and provide lower effective protection because of the difficulties caused by attempting to seal to human faces and heads of all shapes and sizes.

The invention is a lightweight, low cost and low maintenance respirator that is comfortable to wear, provides higher protection because its sealing technique does not depend upon fitting to faces or heads and also makes use of any readily available AC power or, alternatively, batteries in order to make the use of the device as flexible and convenient as possible.

Background Art

Polluted atmospheres threaten the health and safety of many people. Some people are exposed to health and lung damaging particulates or gases during their occupations. Others are exposed during their hobbies or spare time activities. Others are allergy sufferers, being affected by pollen and spores.

Various types of protective devices are currently available. The negative pressure respirators available are generally ineffective because of the difficulty of sealing to a large variety of face shapes and sizes. Generally people can find them unsuitable to wear for long

SUBSTITUTE SHEET



1 periods. The positive pressure devices available are generally heavy, rigid and cumbersome, generally being constructed around bulky and heavy helmets or hoods that may require trailing hoses. Such respirators are generally expensive to purchase and to maintain.

5 The invention claimed and disclosed herein is intended to overcome the difficulties of existing respirators and to solve problems that exist for people who are exposed to polluted atmospheres.

Disclosure of Invention

A powered filtered air respirator comprising of a non-rigid
10 headcover, an electric motor and fan unit, and at least one filter. The electric motor is connected to an alternating current source or may be powered by a battery.

It is the general objective of this invention to provide a low cost, useful means of purifying air before it is breathed.

15 Another objective is to provide a means of connecting to readily available alternating current so as to power the device.

Another objective is to provide a lightweight, comfortable device, suitable for general use by men and women, being flexible, light, non-rigid and portable.

20 It is another objective to provide a means of connecting to batteries.

Another objective is to cover the entire head including hair, face, ears and nose so that these are also protected from dirt, dust, fibers, fumes, grit, smoke and so on.

25 Another objective is to cover the entire head so that difficulties associated with sealing against the nose, mouth and face are not encountered.

Another objective is to use the extensive power available from alternating current sources to overcome the back pressure associated
30 with filters, particularly with gas filters.

Other more specific objectives and advantages of the invention will become apparent after referring to the following description and drawings.

1 Brief Description of Drawings

Figure 1 shows one form of the invention. It shows a non-rigid headcover(1) completely covering the wearer's head. A breathing tube (2) connects the headcover to the filtration assembly (3). In this
5 instance, the electric blower (11) is located inside the filtration assembly with the filter (14). The motor can be powered with electric power through a cord (12) and appropriate plug (13).

Figure 2 is an alternative form of the invention in which a rigid headcover section (1) protects the user from sharp blows to the head.

10 Figure 3 is an alternative form of the invention in which the filtration assembly (4) is in combination with the headcover (1). This arrangement eliminates the need for a breathing tube.

Best Mode For Carrying Out the Invention

This invention will now be described in accordance with the accompanying drawings. Figure 1 shows a form of the invention comprising
15 of a headcover (1) which completely encloses the user's head. It consists of a fabric top (4), visor (5), and inner liner (7). The fabric top (4) can be of a variety of materials depending on durability, costs and application as can the visor and inner liner. An elastic neck
20 section (6) is used to restrict the airflow leaving the headcover (4), creating a positive pressure inside. This assures that no contamination can enter inside the headcover (1), where the user is breathing.

The breathing tube (2) attaches directly to the lower rear of the headcover (1) and consists of a fabric tube (8) with an inner coil
25 expander (9). The inner coil expander (9) keeps the fabric tube from bending or flattening restricting the passage of filtered air to the headcover (1).

Through the use of a clamp (7), the filtration assembly (3) is connected to the breathing tube (2). A motor and fan (10) draws air
30 through the filter (14), into the breathing tube (2) and inside the headcover (1). The motor and fan (11) is supplied with electric power through a cord (12) and appropriate plug (13). Various different power sources can be used being alternating or direct current and either mobile or stationary.

1 The filter (14) can be replaceable or reusable and can remove particulates, gases or both. It is attached to, and sealed by, a filter retainer (15) to the filtration casing (10). A clip (16) is used to attach the filtration assembly (3) to the user.

5 Figure 2 is an alternate form of the invention. In this variation a rigid headcover section (1) incorporating a head harness (2) protects the users from sharp blows to the head due to flying objects, falls, etc. A fabric headcover section (3) with visor (4) is attached to the rigid headcover section (1). It is basically of the same configuration as seen in Figure 1. The breathing tube (5) attaches to the lower rear of the fabric headcover section (3), again as is seen in Figure 1. An electrical switch (6) can be used to continue or discontinue the flow of power to the motor and fan (not shown). Solar cells (7) located on the top of the rigid headcover section (1) add electrical power to any mobile power source or act in a recharging fashion when the unit is not in operation.

Figure 3 is another form of the invention, in which the filtration assembly (4) is in combination with the headcover (1). As was seen before, the headcover (1) consists of a fabric top (2), visor (3) and inner liner (11). The motor and fan (6) draw air through the filter (9) and force it directly inside the headcover (1) eliminating the breathing tube (not shown). To prevent against an influx of contamination, a filter retainer (10) is used to seal the filter (9) to the casing (5). Power for the motor and fan (6) is supplied through the use of an electrical cord (7) and appropriate plug (8).

Industrial Applicability

The widespread applicability of the invention in industry is obvious. Many occupations involve the exposure or the risk of exposure to potentially harmful atmospheres. The invention provides unique and useful features and benefits, such as low manufacturing cost, high protection factors, high user comfort and flexibility of design to incorporate various power sources, headcover designs and filters.

CLAIMS

I claim:

1. A respirator comprising of
a headcover incorporating at least one transparent section, at
least one inlet and at least one outlet.
an electric motor and fan unit providing air moving means to
said headcover.
a substantially non-rigid airpath or fluid path means between
said electric motor and fan unit and said headcover.
at least one filter in combination with said motor and fan unit,
said airpath means and said headcover. Said filter or filters
to remove particulates, gases or both.
2. The respirator of Claim 1 in which said electric motor and fan unit
are powered by alternating current from a fixed or portable source,
connected by obvious means.
3. The respirator of Claim 1 in which said electric motor and fan unit
are powered by direct current from a fixed or portable source, con-
nected by obvious means.
4. The respirator of Claim 1 in which at least one section of said
headcover is substantially rigid.
5. The respirator of Claim 1 in which the headcover is substantially
non-rigid.
6. The respirator of Claim 1 in which at least one section of said
airpath means is substantially rigid.
7. The respirator of Claim 1 in which said headcover incorporates
an inner lining. Said inner lining being a portion of said air-
path.
8. The respirator of Claim 1 in which the said airpath is continuous
from said motor and fan unit into said headcover. Said airpath
being functionally and materially independent of the said head-
cover.

- 1 9. The respirator of Claim 1 in which said electric motor and fan
unit and said filter are located outside said headcover.
10. The respirator of Claim 1 in which one or both said electric motor
and fan unit and said filter are located inside or attached to
5 said headcover.
11. The respirator of Claim 3 in which said electric motor is powered
by direct current from a portable source located on or inside
said headcover.
12. The respirator of Claim 1 incorporating an electrical switch for
10 manually or automatically for turning on and off said electric
motor and fan unit.
13. The respirator of Claim 1 incorporating a securing means for at-
taching said headcover to user's head.
14. The respirator of Claim 1 in which said headcover covers the com-
15 plete head and face of the wearer and extends on all sides down to
and around the wearer's neck.
15. The respirator of Claim 1 incorporating hearing protection devices
attached to said headcover or any other obvious part.
16. The respirator of Claim 1 in which said electric motor is powered
20 by a power source incorporating an energy conversion device. .
Said energy conversion device could be at least one solar cell.
17. A respirator comprising of:
a substantially non-rigid headcover incorporating one trans-
25 parent section, said headcover covering the complete head and
face of the wearer and extending on all sides down to and
around the wearer's neck.
An electric motor and fan unit providing air moving means to
said cover, said electric motor and fan unit being located
outside said headcover.
30 A substantially non-rigid continuous airpath means between
said electric motor and fan unit and said headcover.
An outlet or outlets adjacent to the wearer's neck.

1 A means of powering said electric motor and fan unit by con-
necting to a fixed or portable alternating current source.

At least one filter in combination with said motor and fan
unit, said airpath means and said headcover. Said filter or
5 filters to remove particulates, gases or both.

18. The respirator of Claim 17 in which said electric motor and fan
unit and said filter are located inside said headcover.
19. The respirator of Claim 17 in which said electric motor and fan
unit is powered by connecting said motor to a direct current source.
10 Said source being located either inside or outside said headcover.
20. The respirator of Claim 17 in which at least one section of said
headcover is substantially rigid.

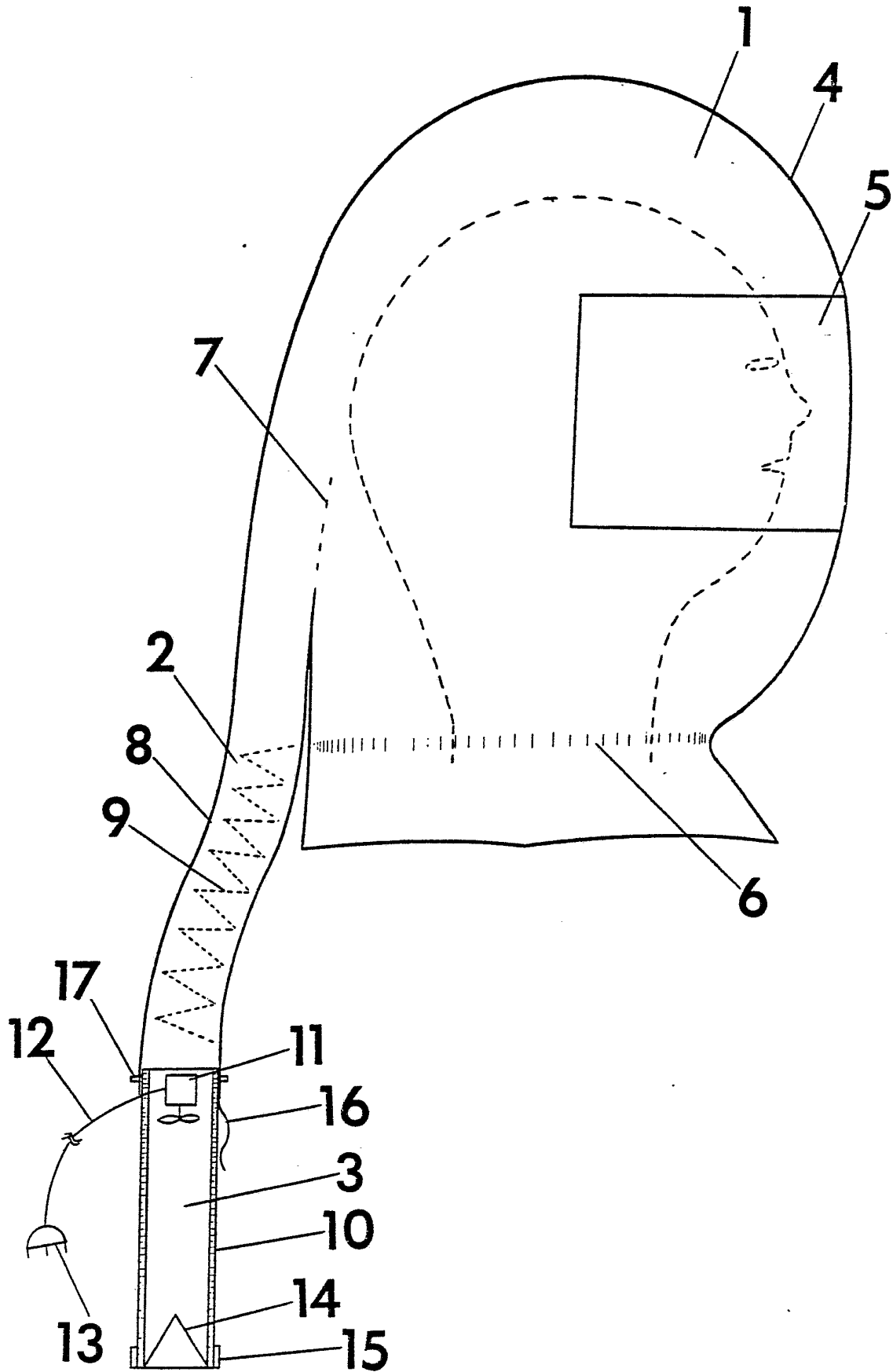

FIGURE 1

SUBSTITUTE SHEET



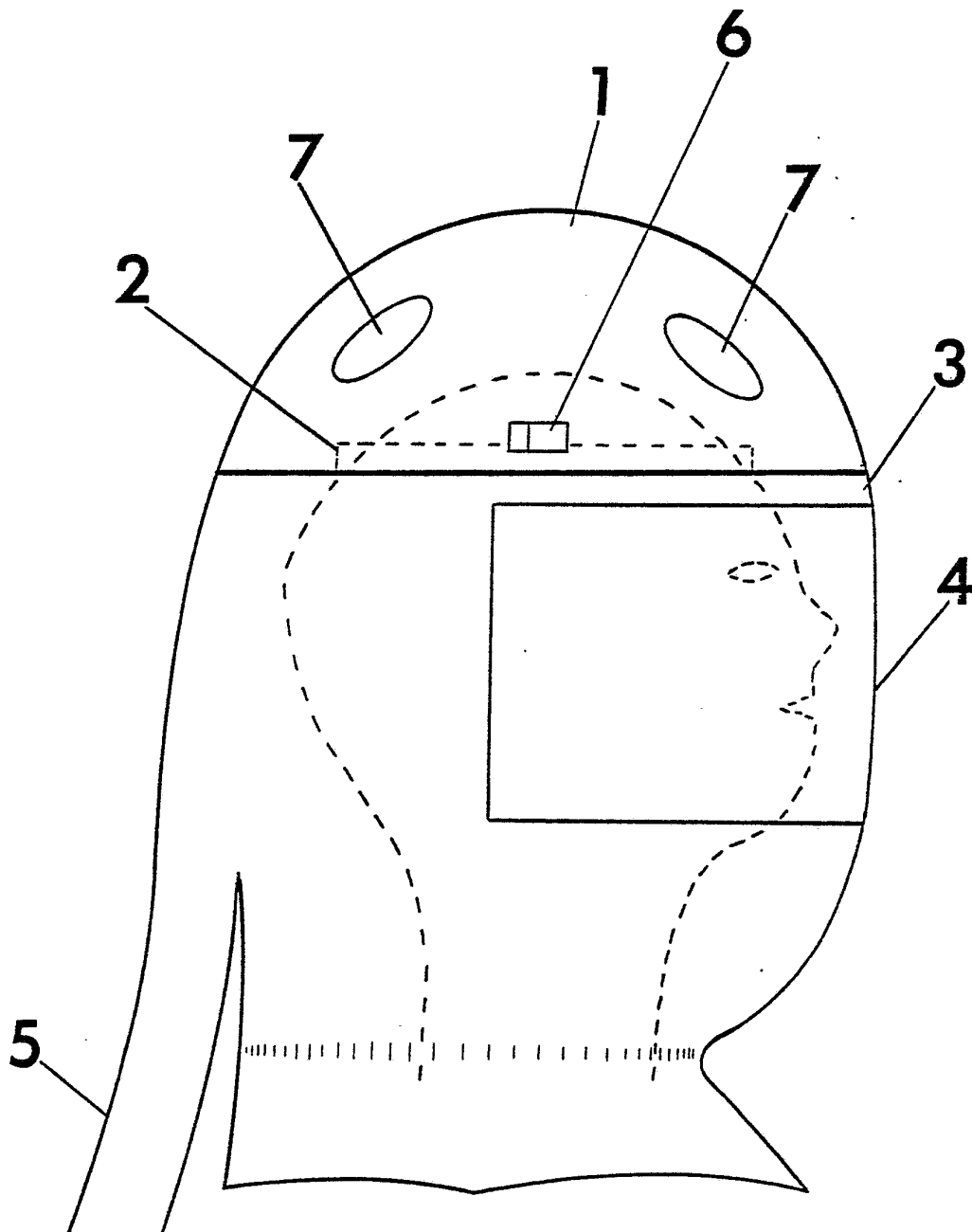

FIGURE 2

SUBSTITUTE SHEET



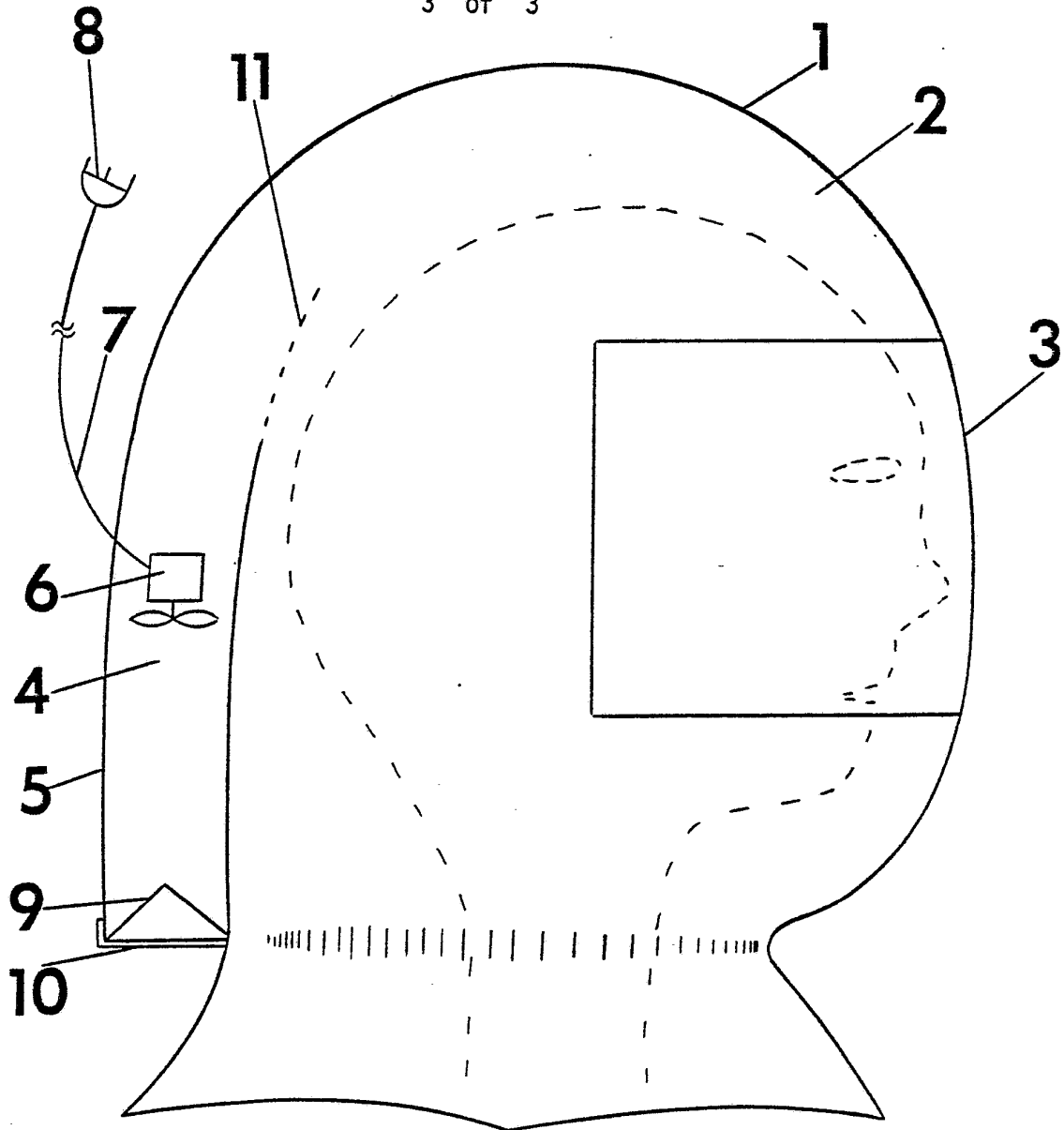

FIGURE 3
SUBSTITUTE SHEET



INTERNATIONAL SEARCH REPORT

International Application No PCT/US82/01164

I. CLASSIFICATION OF SUBJECT MATTER (if several classification symbols apply, indicate all) ³		
According to International Patent Classification (IPC) or to both National Classification and IPC		
INT. CL. ⁸ A62B7/10		
U.S. CL. 128/201.25		
II. FIELDS SEARCHED		
Minimum Documentation Searched ⁴		
Classification System	Classification Symbols	
U.S.	128/201.23, 201.25, 201.29, 205.12.	
Documentation Searched other than Minimum Documentation to the Extent that such Documents are Included in the Fields Searched ⁵		
III. DOCUMENTS CONSIDERED TO BE RELEVANT ¹⁴		
Category *	Citation of Document, ¹⁶ with indication, where appropriate, of the relevant passages ¹⁷	Relevant to Claim No. ¹⁸
X	U S, A, 232,233 Published 14 September 1880 Beyer	1-20
Y	U S, A, 2,332,662 Published 20 October 1943 Nathanson	1-20
Y	U S, A, 3,963,021 Published 15 June 1976 Bancroft	10,18
Y	U S, A, 3,895,625 Published 22 July 1975 Delest	11
PY	U S, A, 4,331,141 Published 25 May 1982 Pokhis	17,19,20
<p>* Special categories of cited documents: ¹⁵</p> <p>"A" document defining the general state of the art which is not considered to be of particular relevance</p> <p>"E" earlier document but published on or after the international filing date</p> <p>"L" document which may throw doubts on priority claim(s) or which is cited to establish the publication date of another citation or other special reason (as specified)</p> <p>"O" document referring to an oral disclosure, use, exhibition or other means</p> <p>"P" document published prior to the international filing date but later than the priority date claimed</p> <p>"T" later document published after the international filing date or priority date and not in conflict with the application but cited to understand the principle or theory underlying the invention</p> <p>"X" document of particular relevance; the claimed invention cannot be considered novel or cannot be considered to involve an inventive step</p> <p>"Y" document of particular relevance; the claimed invention cannot be considered to involve an inventive step when the document is combined with one or more other such documents, such combination being obvious to a person skilled in the art.</p> <p>"&" document member of the same patent family</p>		
IV. CERTIFICATION		
Date of the Actual Completion of the International Search ²	Date of Mailing of this International Search Report ²	
International Searching Authority ¹	<div style="font-size: 1.2em; font-weight: bold; margin-bottom: 5px;">23 DEC 1982</div> Signature of Authorized Officer ²⁰ 	