

(19) **DANMARK**

(10) **DK/EP 3680416 T3**



Patent- og
Varemærkestyrelsen

(12) **Oversættelse af
europæisk patentskrift**

-
- (51) Int.Cl.: **E 04 D 13/147 (2006.01)**
- (45) Oversættelsen bekendtgjort den: **2023-04-03**
- (80) Dato for Den Europæiske Patentmyndigheds bekendtgørelse om meddelelse af patentet: **2023-01-18**
- (86) Europæisk ansøgning nr.: **20150909.8**
- (86) Europæisk indleveringsdag: **2020-01-09**
- (87) Den europæiske ansøgnings publiceringsdag: **2020-07-15**
- (30) Prioritet: **2019-01-10 DK PA201970014**
- (84) Designerede stater: **AL AT BE BG CH CY CZ DE DK EE ES FI FR GB GR HR HU IE IS IT LI LT LU LV MC MK MT NL NO PL PT RO RS SE SI SK SM TR**
- (73) Patenthaver: **VKR HOLDING A/S, Breettevej 18, 2970 Hørsholm, Danmark**
- (72) Opfinder: **Allesen, Torben Krogsgaard, c/o VKR Holding A/S, Breettevej 18, 2970 Hørsholm, Danmark**
- (74) Fuldmægtig i Danmark: **Murgitroyd & Company, Mannerheimvägen 12 B 5th floor, FI-00100 Helsinki, Finland**
- (54) Benævnelse: **A CONNECTOR ELEMENT FOR A FLASHING ASSEMBLY FOR USE IN A ROOF WINDOW ARRANGEMENT AND A METHOD FOR WEATHER PROOFING A ROOF WINDOW ARRANGEMENT**
- (56) Fremdragne publikationer:
EP-A1- 3 039 198
EP-A1- 3 282 064
DE-U1- 7 829 553

DESCRIPTION

[0001] The present invention relates to a connector element for a flashing assembly for use in a roof window arrangement in an inclined roof structure including at least two roof windows, said connector element being configured for being arranged with an exterior side facing the exterior in the mounted state, an interior side facing the roof structure, a first end facing a first roof window, and a length direction of the connector element extending from the first end towards a second opposite open end, where the exterior side comprises a gutter with two longitudinal edges extending between the first and second ends, at least one of said longitudinal edges being configured for engagement with an engagement section of a flashing member, and where a connecting section on the interior side is configured for being connected to a bracket used for connecting a roof window to a load-bearing structure of the roof structure. The invention further relates to a roof window arrangement including such a connector element and to a method for weather proofing a roof window arrangement.

[0002] A connector element of this type is known from EP3039198. This connector element, however, is configured for use where roof windows are mounted side-by-side and is not well suited for use in roof window arrangements, where the windows are mounted one below the other when seen in the direction of inclination of the roof structure.

[0003] It is therefore the object of the invention to provide a connector element, which is configured for use in roof window arrangements, where one roof window is located below the other roof window when seen in the direction of inclination of the roof structure, and a method for weather proofing such a roof window arrangement.

[0004] In a first aspect of the invention this is achieved with a connector element according to claim 1, which is configured for being arranged with the first end at an outer side of a bottom frame member of the first roof window and the second end at an exterior side of the second roof window, where the connector element comprises two end surfaces at the second end, said end surfaces extending from the exterior side towards the interior side and being non-parallel to the length direction, and where at least one attachment element is provided on each of the end surfaces said attachment element being adapted for engagement with a supporting element of a flashing assembly.

[0005] By arranging the connector element with the first end at an outer side of a bottom frame member of the first roof window and the second end at an exterior side of the second roof window, any water condensing at the pane of the first roof window may be drained off onto the exterior side of the second roof window via the gutter. It is noted that the wording "outer side" is here intended to mean a side extending between the exterior side of the roof window facing the exterior and the interior side of the roof window facing the interior covered by the roof structure.

[0006] By providing the connector element with at least one attachment element on each of

the end surfaces at the second end, a supporting element may be attached to it thereby allowing the connector element to not only support a flashing member engaging with the longitudinal edge of the gutter but to also transfer loads from other parts of the flashing assembly to a bracket used for connecting a roof window to a load-bearing structure of the roof structure. In use, the longitudinal edges of the gutter will typically support an end of a middle flashing member extending between the first and second roof windows. The attachment element may then for example be used for the attachment of a support rail extending along the length of the middle flashing member, i.e. in parallel with the top frame member of the second roof window. Such a supporting rail may for example be used for supporting the middle flashing member, so that it does not sag, and/or for supporting a gasket. The attachment element may for example also be used for attachment of a side flashing member supporting element. Further details and examples will be given be-low.

[0007] The end surfaces extend from the longitudinal edges away from the gutter, so that the attachment element(s) do(es) not block the open end of the gutter.

[0008] The connector element has an end surface with an attachment element on both sides of the gutter, and in one embodiment these end surfaces and the attachment elements on the two sides of the gutter are substantially identical except for being mirror inverted, so that the connector element is substantially symmetrical. Making the connector element symmetrical reduces the risk of errors in the mounting process, where connector elements are mounted at both sides of the roof windows.

[0009] Each attachment element includes a male part adapted for engagement with an opening or depression in or on a supporting element. This provides for a relatively easy engagement between the connector element and the supporting element, and alignment between the male part and the opening or depression will serve as an indication that the supporting element has been positioned correctly. In case of an opening, the appearance of the male part within the opening will indicate correct engagement, but a tactile feedback may also help to determine correct engagement. The engagement between the opening or depression and the male part may be a simple engagement where one fits over the other, but it is also possible to achieve a snap-locking engagement. It is also within the scope of the invention to use a female attachment element adapted for engagement with a projection on the supporting element.

[0010] The engagement between a male or female part of an attachment element and a corresponding part on a supporting element may serve as a temporary interconnection, which is later supplemented with another connection, such as a screw connection.

[0011] The attachment element may include an elongate receiver adapted for receiving an elongate fastener, such as a screw. The length direction of the elongate receiver is preferably substantially parallel to the length direction of the connector element, but may extend at other angles if needed in order to achieve an optimal attachment of the supporting element, or in order to give room for other items located on or at the connector element in the mounted state.

[0012] If the elongate receiver is intended to receive a screw, it is preferably made from a polymer with sufficient plasticity and/or elasticity to allow the thread of the screw to cut into it without causing unintentional damage. Examples of such materials are acrylonitrile butadiene styrene (ABS), polyethylene (PE), polypropylene (PP) and polyvinylchloride (PVC).

[0013] In one embodiment, the entire connector element is made from the same material. It may be made in one piece, for example by moulding or 3D printing, but it may also be advantageous to assemble it from two or more parts.

[0014] A second aspect of the invention relates to a roof window arrangement for use in an inclined roof structure including at least two roof windows, where a first roof window is located above a second roof window when seen in the direction of inclination of the roof structure, and a flashing assembly, said flashing assembly including at least one connector element as described above arranged with the first end at an outer side of a bottom frame member of the first roof window and the second end at an exterior side of the second roof window, at least a middle flashing member extending between the two roof windows, and a supporting element adapted for supporting one or more flashing members, said supporting element being attached to at least one attachment element of the connector element. This roof window arrangement provides for an improved attachment of the flashing members of the flashing assembly, where loads can be transferred to the load-bearing structure via the connector element and brackets used for connecting a roof window to a load-bearing structure of the roof structure and do not have to be transferred via the frames of the roof windows. This may for example be advantageous where the frames of the roof windows are made from materials, which are not easily penetrated by screws or like fasteners, or where attachment to the frames are undesired, for example to avoid thermal bridges.

[0015] In a third aspect of the invention, the object is achieved with a method for weather proofing a roof window arrangement including at least two roof windows mounted in an inclined roof structure, a first roof window above a second roof window when seen in the direction of inclination of the roof structure, said method comprising the following steps:

- connecting a connecting section of a connector element according to the first aspect of the invention to a bracket used for connecting a roof window to a load-bearing structure of the roof structure, so that said connector element is arranged between the first roof window and the second roof window with an exterior side facing the exterior, an interior side facing the roof structure, a first end facing the first roof window and a second open end being arranged at the second roof window, a length direction of the connector element extending from the first end towards the second end,
- arranging a middle flashing member so that it extends between the two roof windows and so that an engagement section of the middle flashing member is in engagement with a longitudinal edge delimiting a gutter extending between the first and second ends on the exterior side of the connector element,
- attaching a supporting element of a flashing assembly to an attachment element provided on an end surface at the second end of said connector element, said end

surface extending from the exterior side towards the interior side and being non-parallel to the length direction, and

- arranging at least one flashing member of the flashing assembly so that it is supported by the supporting element.

[0016] The order of the steps may vary. For example, it may be advantageous to attach the supporting element before bringing the middle flashing member in engagement with the connector element. The method may include further steps, such as covering the connector element with a connector flashing member.

[0017] Embodiments and advantages described with reference to one aspect of the invention also applies to the other aspects of the invention unless otherwise stated.

[0018] In the following the invention will be described in more detail with reference to the non-limiting embodiments shown in the drawing, where:

Fig. 1 is a perspective partially cut-away view of a roof window arrangement according to the invention,

Fig. 2 corresponds to Fig. 1 but with some of the flashing members removed,

Fig. 3 shows the detail marked III in Fig. 2, where covering and cladding members of the flashing assembly have been removed,

Fig. 4 is a perspective view of a connector element according to the invention,

Fig. 5 is a perspective view of the connector element in Fig. 4 from a different angle,

Fig. 6 is a perspective view of the connector element in Figs 4 and 5 from yet another angle, and

Figs 7-11 are perspective views of different stages of the construction of a roof window arrangement, each view corresponding substantially to the view in Fig. 3, but seen from a different angle.

[0019] A roof window arrangement in an inclined roof structure including a first roof window 1 located above a second roof window 2 when seen in the direction of inclination of the roof structure is seen in Fig. 1. In addition to the roof windows, it comprises a flashing assembly 3 which includes a middle flashing member 30 extending between the two roof windows, a bottom covering 31 and a cladding 32 on the first roof window, a cladding 34 on the second roof window, side flashing members 35, 36 at the first and second roof windows, respectively. Furthermore, it includes a connector flashing member 33 extending between the middle flashing member 30 and the side flashing member 35 of the first roof window 1 and between

the claddings 32, 34 on the two windows.

[0020] As is seen in Fig. 2, where side flashing members 35, 36 and the connector flashing member 33 has been removed, the connector flashing member covers a connector element 6, which is attached to a connector bracket 41 interconnecting the mounting brackets 11,21 of the two roof windows 1,2. The attachment of the connector element to the connector bracket may for example be achieved by passing bolts through openings 611 (see Fig. 3) in a connecting section 61 of the connector element and through similar aligned openings in the connector bracket.

[0021] In Fig. 3, where the bottom covering 31 and the claddings 32,34 have also been removed, the detail marked III in Fig. 2 is seen more clearly.

[0022] The middle flashing member 30 has a bent edge 301 serving as an engagement section, which projects into a gutter 62 on the exterior side of the connector element 6. The engagement with the flange 621 defining the longitudinal edges of the gutter prevents the middle flashing member from moving away from the connector element and from moving towards the interior. When the connector flashing member 33 is mounted on top and attached to the tubular attachment element 622, for example by means of a screw, the middle flashing member is further prevented from moving towards the exterior.

[0023] The connector element is arranged with a first end 601 at the first roof window 1 abutting an outer side of a bottom member of the frame 10 of the first roof window, and a second end 602 above the exterior side of the second window 2.

[0024] The connector element 6 is shown in more detail in Figs 4-6.

[0025] Attachment sections 63 are provided on both sides of the open end of the gutter. Each attachment section 63 comprises a flange 631 defining an end surface at the second end 602, extending from the exterior side towards the interior side and being substantially perpendicular to the length direction L. Each flange is provided with an attachment element 632 on the end surface, here in the form of a frustoconical flange, which defines the opening of an elongate hollow extending into an elongate receiver 633 on the opposite side of flange 631. The elongate hollow extending into the receiver 633 is configured to receive a screw or a like fastener (not shown), which can be used for attaching a supporting element of a flashing assembly or other parts of a flashing assembly to the connector element 6. The fact that the attachment element 632 projects from the end surface means that it may engage with an opening or depression in or on a supporting element.

[0026] Turning now to Figs 7-11 an example of the mounting of a flashing assembly by means of a connector element 6 according to the invention is shown.

[0027] Fig. 7 shows the connector element 6 mounted on the connector bracket (not visible) as in Fig. 2 and extending between the cladding 32 of the first roof window and the cladding 34

of the second roof window. The mounting bracket 11 and frame 12 of the first roof window is seen in the background and a first supporting rail 371 is attached to the top frame member (not visible) of the second roof window.

[0028] In Fig. 8 a supporting element 372 has been attached to the top corner of the frame of the second roof window so that it supports the upper end 341 of cladding 34 and a cover member 373 has been arranged on the exterior side of the cladding 34, so that the upper end 341 is sandwiched between the two. Furthermore, a first gasket 374 has been arranged on the first supporting rail 371, extending along its exterior edge and having a length so that it overlaps with the cover member 373 on the cladding 34. Both the cover member 373 and the first gasket 374 are arranged behind the attachment sections 63 of the connector element 6 and are thus prevented from moving away from the first roof window.

[0029] In Fig. 9 a second supporting rail 375 has been arranged on one side of the connector element 6 on top of the first gasket 374 and a side flashing supporting element 376 has been arranged on the other side of the connector element overlapping the cladding support element 372 and the cover member 373. Both the second supporting rail 375 and the side flashing supporting element 376 are provided with circular openings which have been fitted over the attachment elements 632 of the connector element 6 so that the attachment elements project through the openings.

[0030] In Fig. 10 a second gasket 377 has been attached to both attachment elements 632, two openings in the gasket fitting over them so that this gasket 377 overlaps the gap between the second supporting rail 375 and the side flashing supporting element 376. The outer ends of the frustoconical flanges of the attachment elements 632 are substantially flush with the outer side of the second gasket 377.

[0031] In Fig. 11 the middle flashing member 30 has been arranged with the bent edge 301 projecting into the gutter of the connector element 6 as described above and with a front edge 302 hooking over the second supporting rail 375 and the second gasket 377. The system of rails 371,375 and gaskets 374,377 thus provides a weather-proof connecting between the middle flashing member 30 and the second roof window. The middle flashing element 30 too has an opening 303, which in the correctly mounted state is aligned with the left-hand attachment element on the connector element 6. A screw or like fastener (not shown) may be passed through this opening 303 and directly into the elongate receiver 633 of the connector element 6.

[0032] The side flashing member 35 (shown only in Fig. 1) is provided with a similar opening fitting with the right-hand attachment element 632 and corresponding elongate receiver 633, and the connector flashing member 33 has two openings matching the position of the attachment elements 632 in the same way as described for the second gasket 377. This means that when the connector flashing member 33 has been arranged on top of the middle flashing member 30 and the side flashing member 35, two screws or like fasteners passed through all of the aligned openings are sufficient for securing all three flashing members, the

supporting elements, and the gaskets to the connector element 6 and thus indirectly to the load-bearing structure. This provides for a simple, reliable, and cost-efficient attachment of the flashing assembly.

[0033] It is noted that the embodiment shown and described with reference to the drawing is not to be regarded as limiting the invention, which is defined by the claims. This for example means that some of the supporting elements and gasket described with reference to Figs 7-11 may be left out or modified and that other elements may be added. Likewise, the connector element 6 may have a different shape than what is shown. For example, the attachment sections 63 may be embodied differently. It is also contemplated that supporting elements may be attached to the connector element 6 by a snap-locking engagement.

[0034] Finally, it is noted that the design of the gutter of the connector element 6 and the engagement with the middle flashing member 30 may be achieved in many different ways from what is shown and described. For example, the middle flashing member 30 may be without the bent edge 301.

List of reference numbers

[0035]

1	First roof window
10	Frame of first roof window
11	Mounting bracket
2	Second roof window
21	Mounting bracket
3	Flashing assembly
30	Middle flashing member
301	Bent edge
302	Front edge
303	Opening
31	Bottom covering

32	Cladding
33	Connector flashing member
34	Cladding
35	Side flashing members
36	Side flashing members
371	First supporting rail
372	Supporting element
341	Upper end
373	Cover member
374	First gasket
375	Second supporting rail
376	Side flashing supporting element
377	Second gasket
41	Connector bracket
6	Connector element
601	First end
602	Second end
61	Connecting section
611	Openings
62	Gutter
621	Flange
622	Tubular attachment element

63	Attachment section
631	Flange
632	Attachment element
633	Elongate receiver
L	Length direction

REFERENCES CITED IN THE DESCRIPTION

Cited references

This list of references cited by the applicant is for the reader's convenience only. It does not form part of the European patent document. Even though great care has been taken in compiling the references, errors or omissions cannot be excluded and the EPO disclaims all liability in this regard.

Patent documents cited in the description

- [EP3039198A \[0002\]](#)

PATENTKRAV

1. Konnektorelement (6) til en afdækningsanordning (3) til brug i en tagvinduesanordning i en skrå tagstruktur inklusive mindst to tagvinduer (1, 2), nævnte konnektorelement er
5 konfigureret til at blive placeret med en udvendig side rettet imod det ydre i monteret tilstand, en indvendig side rettet imod tagstrukturen, en første ende (601) rettet imod et første tagvindue (1), og en længderetning (L) af konnektorelementet, der strækker sig fra den første ende imod en anden modsat åben ende (602), hvor den udvendige side omfatter en rende (62) med to langsgående kanter (621), der strækker sig imellem de
10 første og anden ender, mindst en af nævnte langsgående kanter er konfigureret til at gå i indgreb med et indgrebsafsnit (301) på en afdækningsdel (30), og hvor et forbindelsesafsnit (61) på den indvendige side er konfigureret til at være forbundet med et beslag (41) anvendt til at forbinde et tagvindue med en belastningsbærende struktur af tagstrukturen, hvor konnektorelementet (6) er konfigureret til at være placeret med
15 den første ende (601) ved en ydre side af en nederste rammedel på det første tagvindue (1) og den anden ende (602) ved en udvendig side af det andet tagvindue (2),
kendetegnet ved,
at konnektorelementet (6) omfatter to endeflader (631) ved den anden ende (602),
20 nævnte endeflader strækker sig fra den udvendige side imod den indvendige side og er ikke parallelle med længderetningen (L), hvor hver af endefladerne (631) strækker sig fra en af de langsgående kanter (621) væk fra renden, og
at mindst et fastgørelseselement (632) tilvejebringes på hver af endefladerne (631),
hvert fastgørelseselement omfatter en handel (632) tilpasset til at gå i indgreb med en
25 åbning eller fordybning i eller på et støttelement (375) for en afdækningsanordning (6).
2. Konnektorelement ifølge krav 1, hvor fastgørelseselementet (632) omfatter en aflang modtager (633) tilpasset til modtagelse af en aflang fastgørelse, såsom en skrue.
- 30 3. Konnektorelement ifølge krav 2, hvor den aflange modtagers (633) længderetning hovedsageligt er parallel med konnektorelementets længderetning (L).
4. Konnektorelement ifølge et eller flere af kravene 1-3, hvor endefladerne (631) og fastgørelseselementerne (632) på to af siderne på renden (62) hovedsageligt er
35 identiske med undtagelse af at være spejlvendte, så konnektorelementet (6) hovedsageligt er symmetrisk.
5. Tagvinduesanordning til brug i en skrå tagstruktur inklusive mindst to tagvinduer (1, 2),

- 5 hvor et første tagvindue (1) er placeret over et andet tagvindue (2) set i retning af tagstrukturens hældning, og en afdækningsanordning (3), nævnte afdækningsanordning inklusive mindst et konnektorelement (6) ifølge et eller flere af kravene 1-4 placeret med den første ende (601) ved en ydre side af en nederste rammedel på det første tagvindue (1) og den anden ende (602) ved en ydre side af det andet tagvindue (2), mindst en mellemafdækningsdel (30), der strækker sig imellem de to tagvinduer (1, 2), og et støtteelement (375) tilpasset til at støtte en eller flere afdækningsdele, nævnte støtteelement er fastgjort til mindst et fastgørelseselement (632) på konnektorelementet.
- 10
6. Fremgangsmåde for vejrtæthed af en tagvinduesanordning inklusive mindst to tagvinduer (1, 2) monteret på en skrå tagstruktur, et første tagvindue (1) over et andet tagvindue (2) set i retning af tagstrukturens skråning, nævnte fremgangsmåde omfatter følgende trin:
- 15
- tilslutning af et konnektorelements (6) forbindelsesafsnit (61) ifølge et eller flere af kravene 1-4 til et beslag (41) brugt til at tilslutte et tagvindue med en belastningsbærende struktur af tagstrukturen, således at nævnte konnektorelement er placeret imellem det første tagvindue (1) og det andet tagvindue (2) med en udvendig side rettet imod det ydre, en indvendig side rettet imod tagstrukturen, en første ende (601) rettet imod det første tagvindue og en anden åben ende, der er placeret ved det andet tagvindue, en længderetning (L) af konnektorelementet strækker sig fra den første ende (601) imod den anden ende (602),

20

 - placering af mellemafdækningsdelen (30), således at den strækker sig imellem to tagvinduer (1, 2), og således at et indgrebsafsnit (301) på mellemafdækningsdelen er i indgreb med en langsgående kant (621), der afgrænser en rende (62), der strækker sig imellem de første og anden ender (601, 602) på konnektorelementets ydre side,

25

 - fastgørelse af et støtteelement (375) på en afdækningsanordning (3) til et fastgørelseselement (632) tilvejebragt på en endeflade (631) ved den anden ende (602) af nævnte konnektorelement, nævnte endeflade strækker sig fra den udvendige side imod den indvendige side og er ikke parallel med længderetningen (L), og

30

 - placering af mindst en afdækningsdel (30) på afdækningsanordningen, således at den understøttes af støtteelementet (375).

35

DRAWINGS

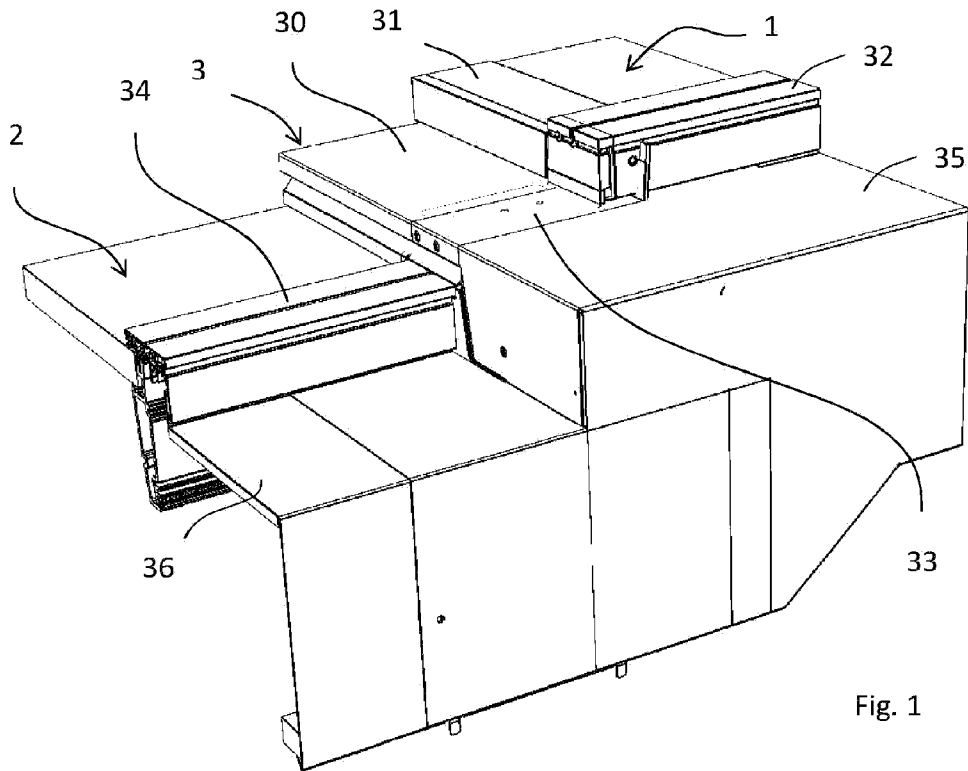

Fig. 1

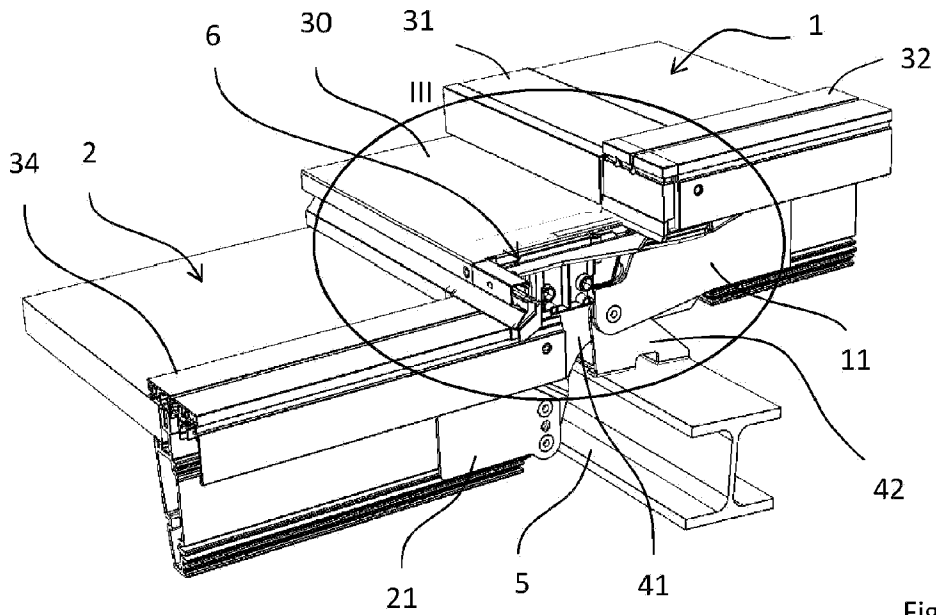

Fig. 2

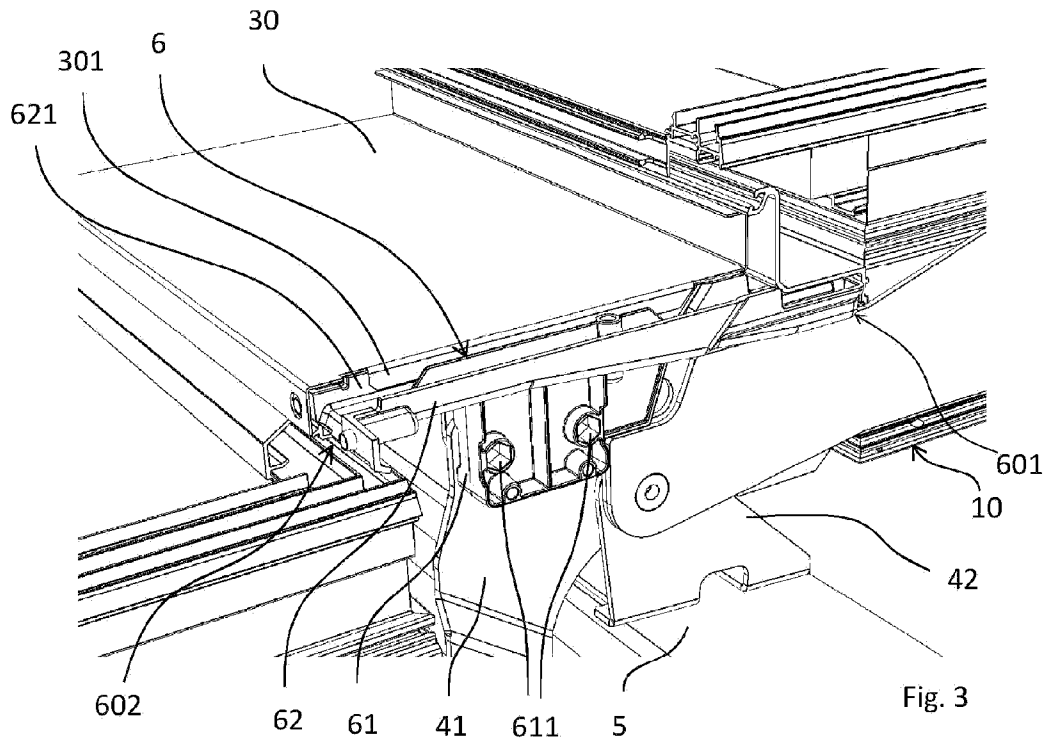

Fig. 3

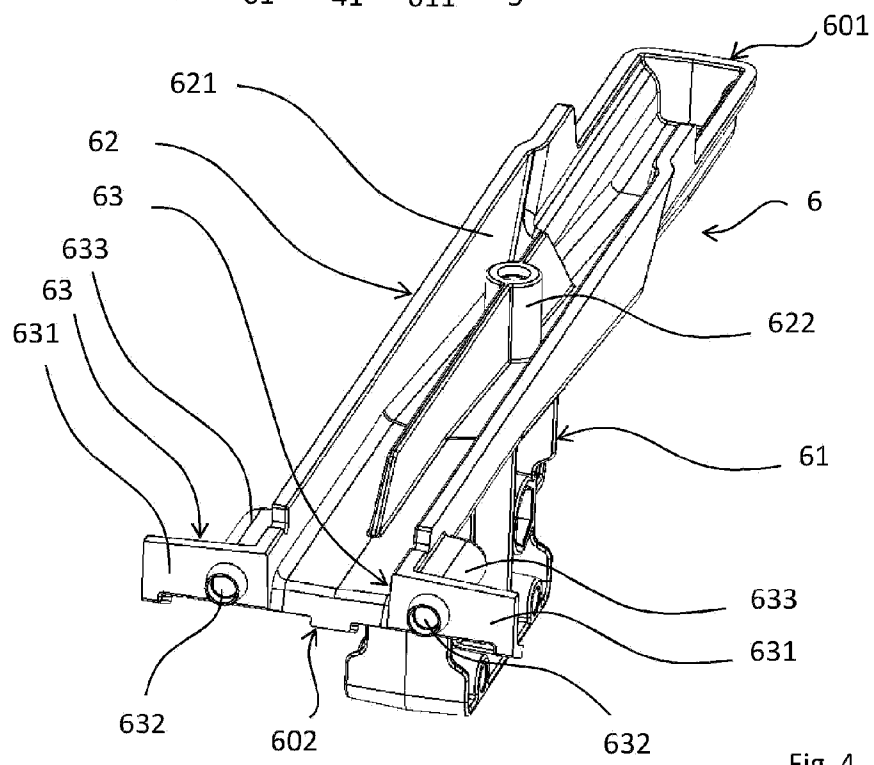

Fig. 4

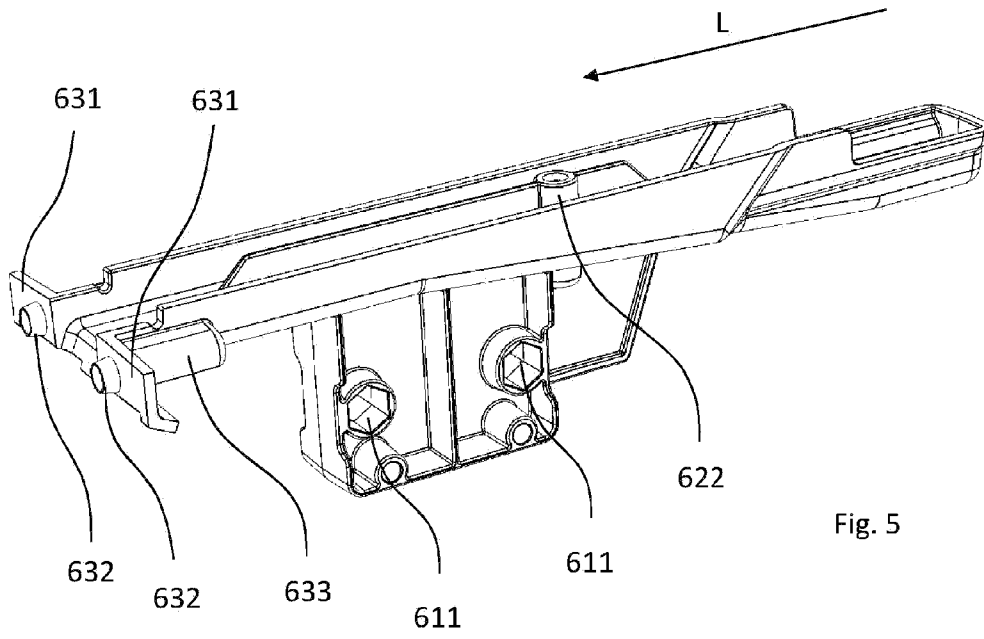

Fig. 5

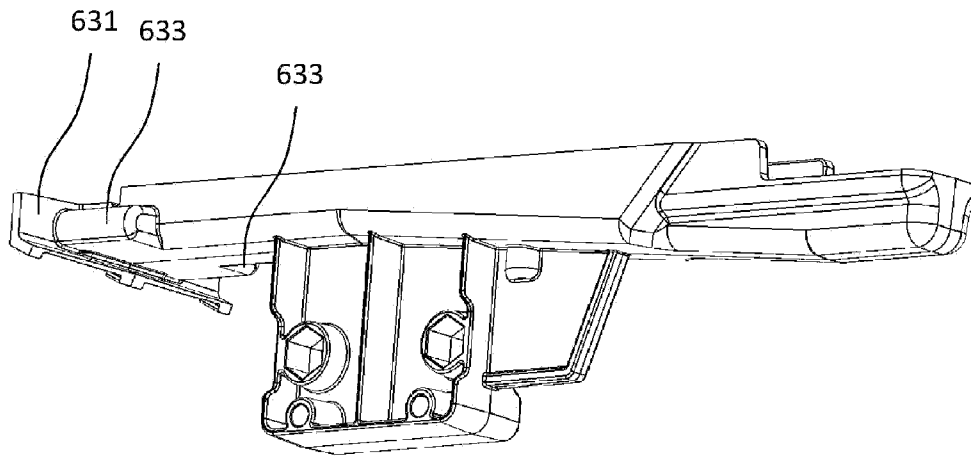

Fig. 6

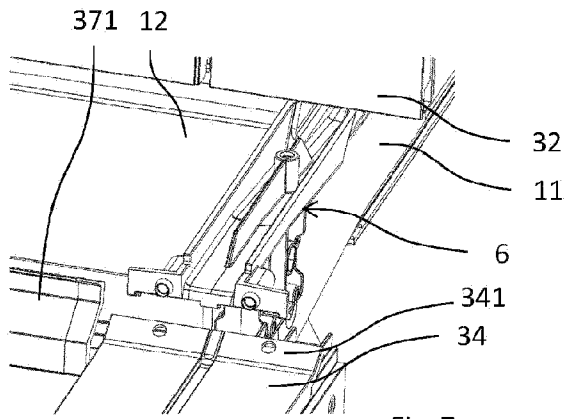

Fig. 7

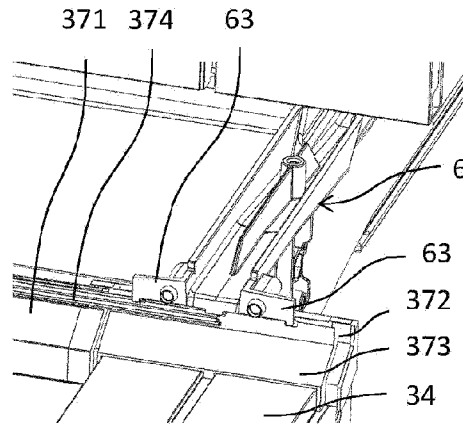

Fig. 8

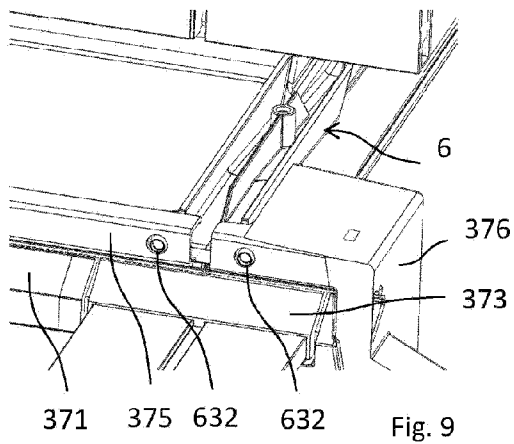

Fig. 9

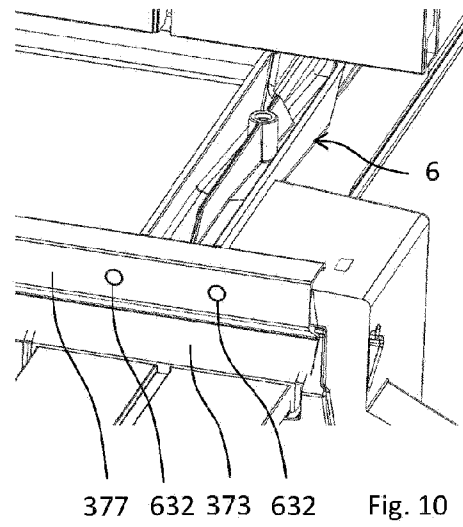

Fig. 10

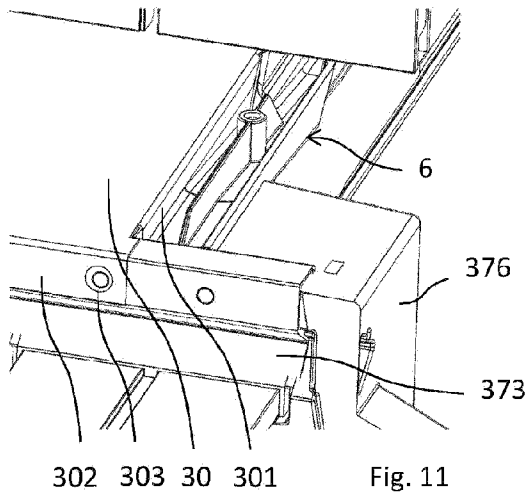

Fig. 11