

(19)
(12)

(KR)
(A)

(51) 。 Int. Cl. ⁷
B65B 25/04

(11)
(43)

2003 - 0000100
2003 01 06

(21) 10 - 2001 - 0035747
(22) 2001 06 22

(71) 1125 - 3 2 325 - 804

(72) 1125 - 3 2 325 - 804

(74)

:

(54)

(1) ,

(p)

(a)

가

(p)

(130)

(100)

(210) ,

(220)

(2)

(p)

(200)

,

(111)

가

(s)

(112)

(110)

(120) ,

(p)

(100) ,

(p)

(s)

,

1 ,
2 ,
3 ,
4 ,
5 ,
6 ,
7 .

* *

1; 100;
101; 102;
110; 112;
120; 124;
130; 131;
133; 134;
138; 200;
210; 211;
212; 220;
222; a;
p; s;

가 가 ,

가

1 , 3 , 2 , 4 , 5 , 6

(1) 1 2 ,
(p) 가 (s) , () (120) , (p)
(110) , (p) (p) (130)

(100) , (100) (2) , (p)
(210) ,
(p) (220) (200) (s) ,
()

(100) (2) (120) 1 3 , ,
 (p) 가 (121) (122)
 (123) ,
 (p) (123) (130)가 (124)가 (s) (130)
 (124)가 (2)
 (p) (130) (p) , , .
 (130) (131) 3 4 (100)
 ' Z ' (132) (130) (133)가
 , ,
 (134) (131) (100) (101)
 (101) (134) (102) .
 6) (101) ' T ' (134) (135) (13)
 (137) .
 (p) (138)가 .
 (p) (120) (a) (120)
 (110) (110)
 (131,134) (110) 2 3 (120) (124,138)
 가 ,
 (111) 가 (s) ,
 (a) (112) .
 (2) (100) (p) (a) (1)
 (200) ,
 (200) 6 7 ,
 (2) (100) (a) (p) (p)
 (220)가 ,
 (221) (220) , 가 (s) (222) (p)

가 , (220) (2) (p) (210)

(210) (2) (p) (212) ,

(s) , (p) (211) .

, (1) 1 (a) (100)

(112) ,

(120) (124)가 (s)

(123) (p)

(124) (p) 2 3 (130)가

(p) , (101) (102) (138)

, (124,138) (p) 가 (p) (1) (124)

5 a) (p) (a) (p) 가 ,

5 b) (p) , (131,134) (p)가

(124,138) (p) 가 가

(p) (a) (1) 2 (a) (112) (s)

(p) (a)

(a) (p) (110) (120),

(130) (100) ,

(a) (p) (2) (200) .

(200) (a) (p) (1) 2 6

(220)가 (p) ,

(221) (s) (222) (p) 가 (220) 7

.

(p) (220) ,

1)가 (2) (220) 가 (210) 가 (s) (21

(212) (p)

(p) (220) (p)
 ,
 (210) (p) (p) 가 ,
 ,
 (210) 가

,
 가

(57)

1.

;

(1) ,

(p)

(a)

가

(p)
 (130)

(111)

가

(s)

(112)

(110)

(120) ,

(p)

(100) ,

(100)

(2)

,

(p)

(210) ,

(p)

(s)

,

(220)

(200)

.

2.

1

;

(120) ,

(1)

(2)

,

(p)

가

(121)

(122)

(123),

(p)

(s)

(124) ,

(100) (101) (102) (p)
 (138)

3.

1 ;

(120) ,

'Z' (132) (133)가 (131) ,

(101) (102) (135) (136)
 'T' (137) (134) ,

, (131,134) , (124,138)가 (130)

4.

1 ;

(200) ,

(s) (221)

가 (222) (220) ,

(2) (p) (211) ,

(212) 가 (s) , (p)

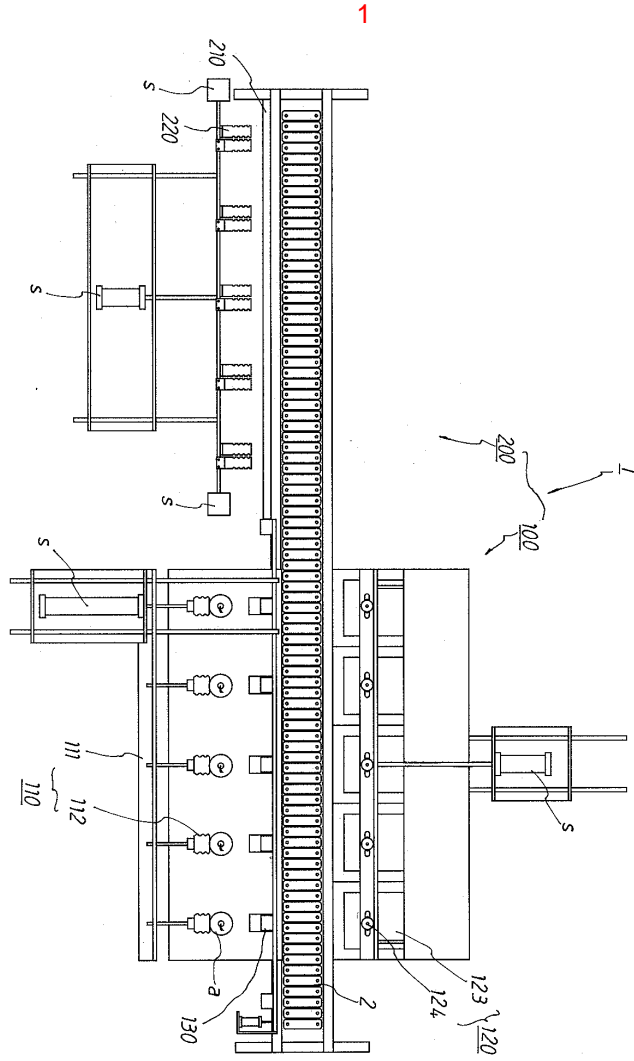

2

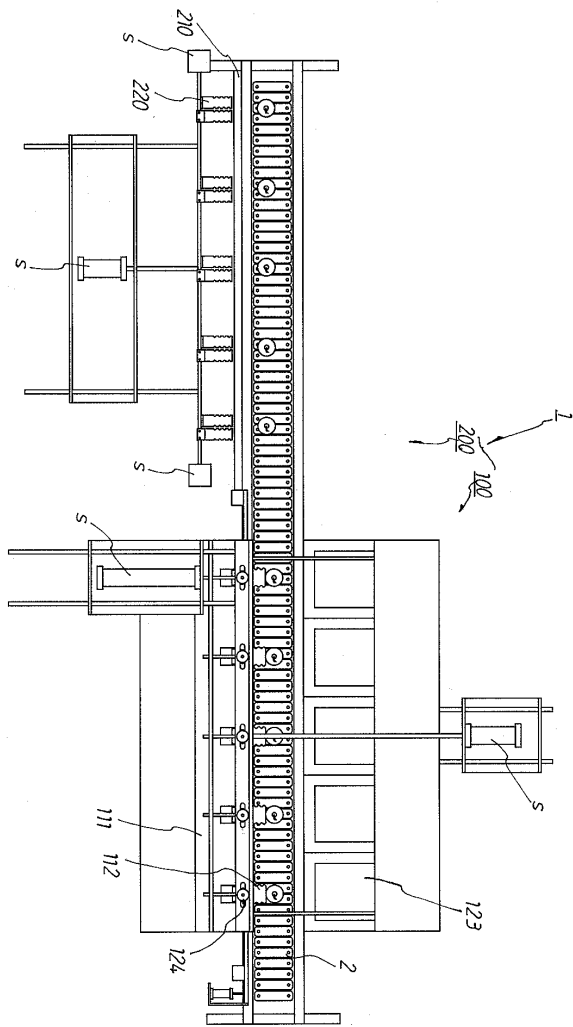

3

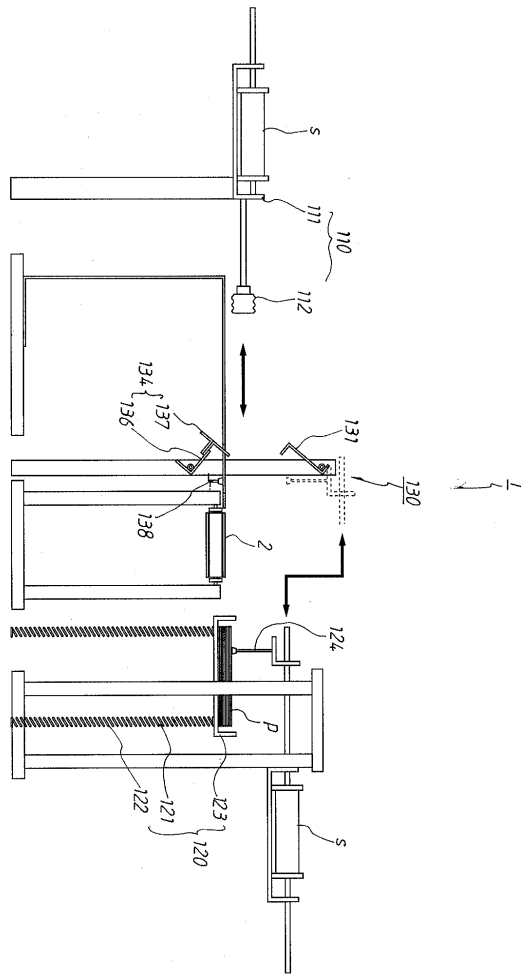

4

