



US0D1007348S

(12) **United States Design Patent**
Selic

(10) **Patent No.:** **US D1,007,348 S**

(45) **Date of Patent:** **** Dec. 12, 2023**

(54) **CLAMPING AND LOCATING ANGLE**

(71) Applicant: **Bernd Siegmund GmbH**,
Oberottmarshausen (DE)

(72) Inventor: **Mario Selic**, Augsburg (DE)

(73) Assignee: **Bernd Siegmund GmbH**,
Oberottmarshausen (DE)

(**) Term: **15 Years**

(21) Appl. No.: **29/862,375**

(22) Filed: **Dec. 8, 2022**

Related U.S. Application Data

(62) Division of application No. 29/779,090, filed on Apr. 16, 2021, now Pat. No. Des. 988,152.

Foreign Application Priority Data

(30)
Oct. 17, 2020 (EM) 008202170-0001
Oct. 17, 2020 (EM) 008202170-0002
Oct. 17, 2020 (EM) 008202170-0003
Oct. 17, 2020 (EM) 008202170-0004
Oct. 17, 2020 (EM) 008202170-0007
Oct. 17, 2020 (EM) 008202170-0008
Oct. 17, 2020 (EM) 008202170-0011
Oct. 17, 2020 (EM) 008202170-0012

(51) **LOC (14) Cl.** **10-04**

(52) **U.S. Cl.**
USPC **D10/64; D10/65**

(58) **Field of Classification Search**
USPC D10/62, 64, 65, 71
CPC B43L 7/005; G01B 1/00
See application file for complete search history.

(56) **References Cited**

U.S. PATENT DOCUMENTS

D289,981 S * 5/1987 Porter D10/64
D659,031 S * 5/2012 MacKay D10/65

* cited by examiner

Primary Examiner — Antoine Duval Davis

(74) *Attorney, Agent, or Firm* — Henry M. Feiereisen
LLC

(57) **CLAIM**

The ornamental design for a clamping and locating angle, as shown and described.

DESCRIPTION

FIG. 1 is a left side, front, top perspective view of a first embodiment of a clamping and locating angle, showing my new design;

FIG. 2 is a front elevation view thereof;

FIG. 3 is a right side elevation view thereof;

FIG. 4 is a rear elevation view thereof;

FIG. 5 is a left side elevation view thereof;

FIG. 6 is a top plan view thereof;

FIG. 7 is a bottom plan view thereof;

FIG. 8 is a rear, left side, top perspective view thereof; and

FIG. 9 is a right side, front, bottom perspective view thereof;

FIG. 10 is a right side, front, top perspective view of a second embodiment of a clamping and locating angle, showing my new design;

FIG. 11 is a front elevation view thereof;

FIG. 12 is a right side elevation view thereof;

FIG. 13 is a rear elevation view thereof;

FIG. 14 is a left side elevation view thereof;

FIG. 15 is a top plan view thereof;

FIG. 16 is a bottom plan view thereof;

FIG. 17 is a right side, rear, top perspective view thereof; and,

FIG. 18 is a left side, bottom, front perspective view thereof.

1 Claim, 18 Drawing Sheets

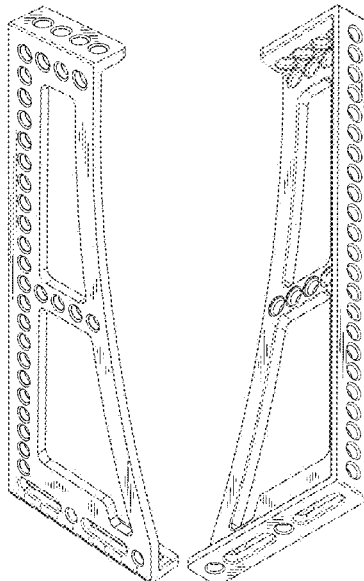

FIG. 1

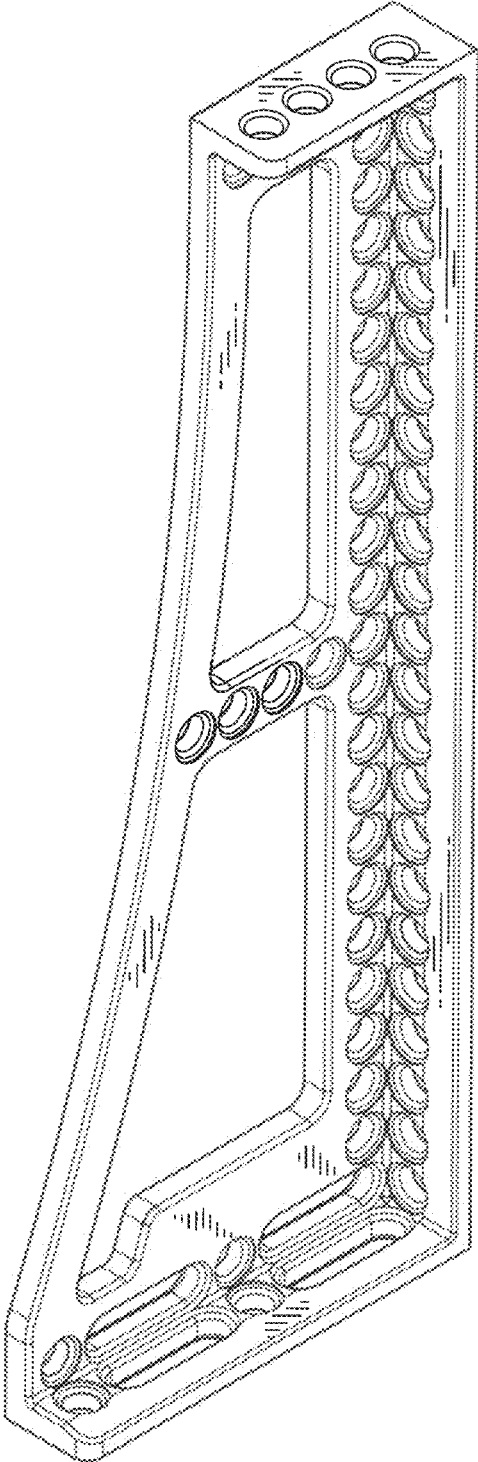

FIG. 2

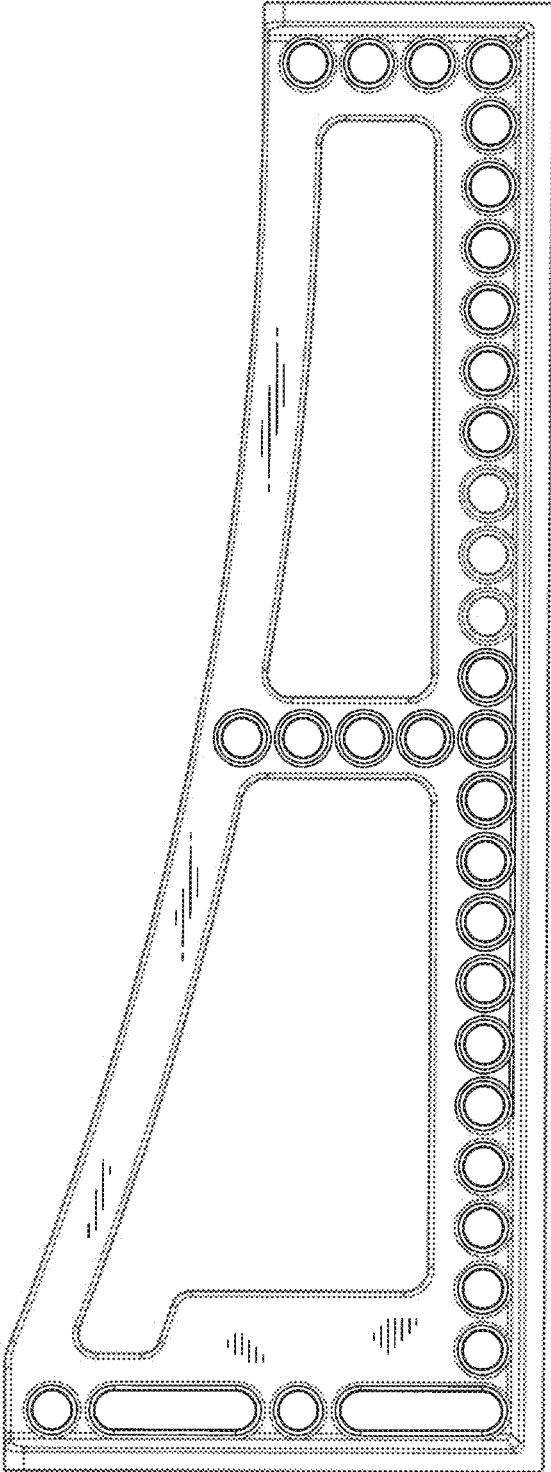

FIG. 3

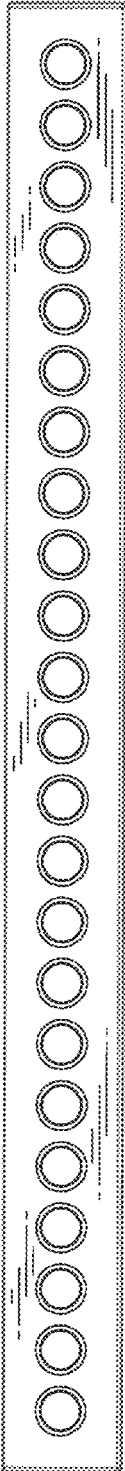

FIG. 4

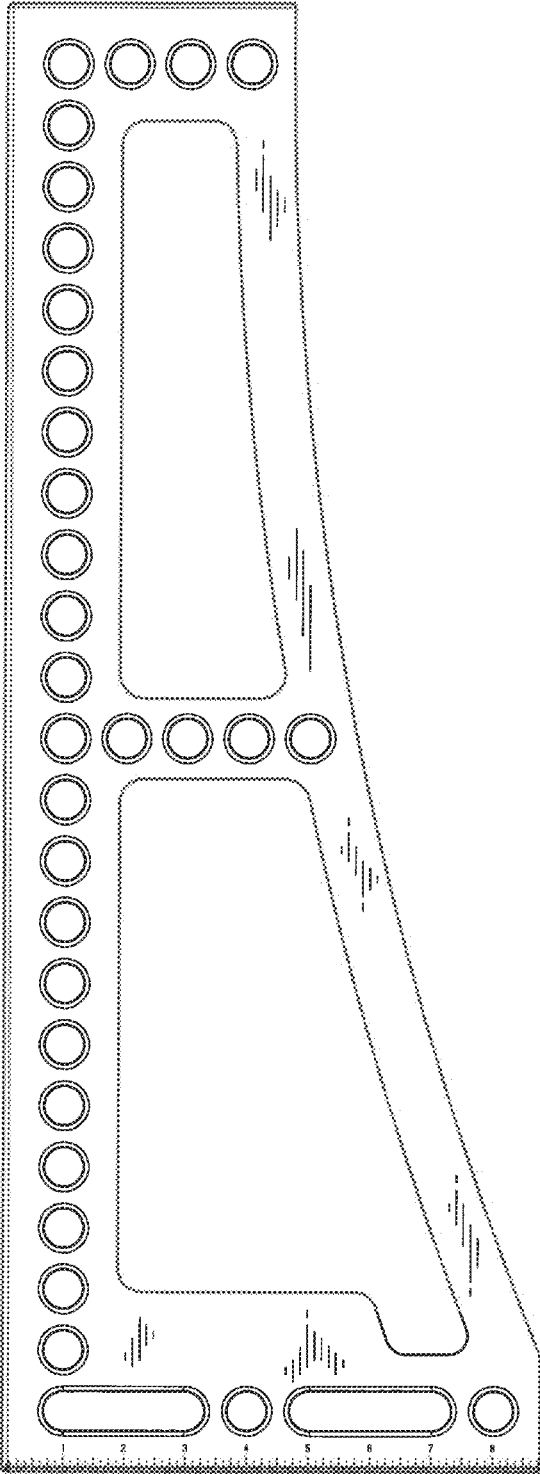

FIG. 5

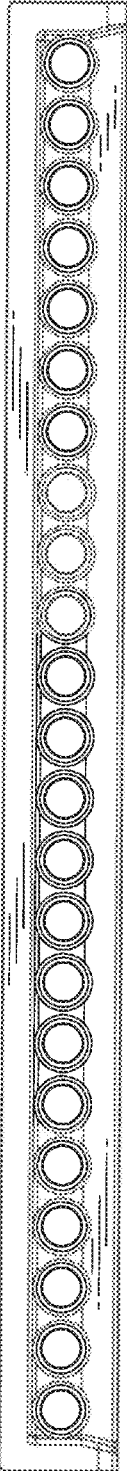

FIG. 6



FIG. 7

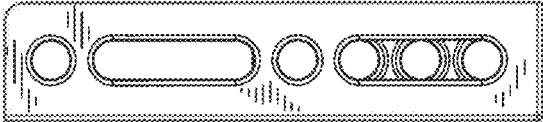

FIG. 8

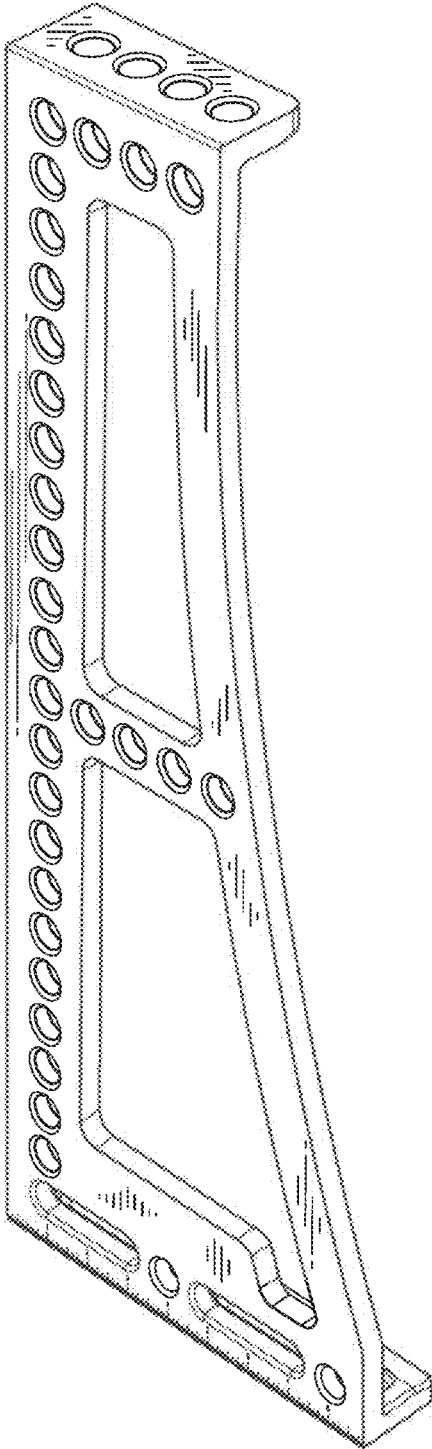

FIG. 9

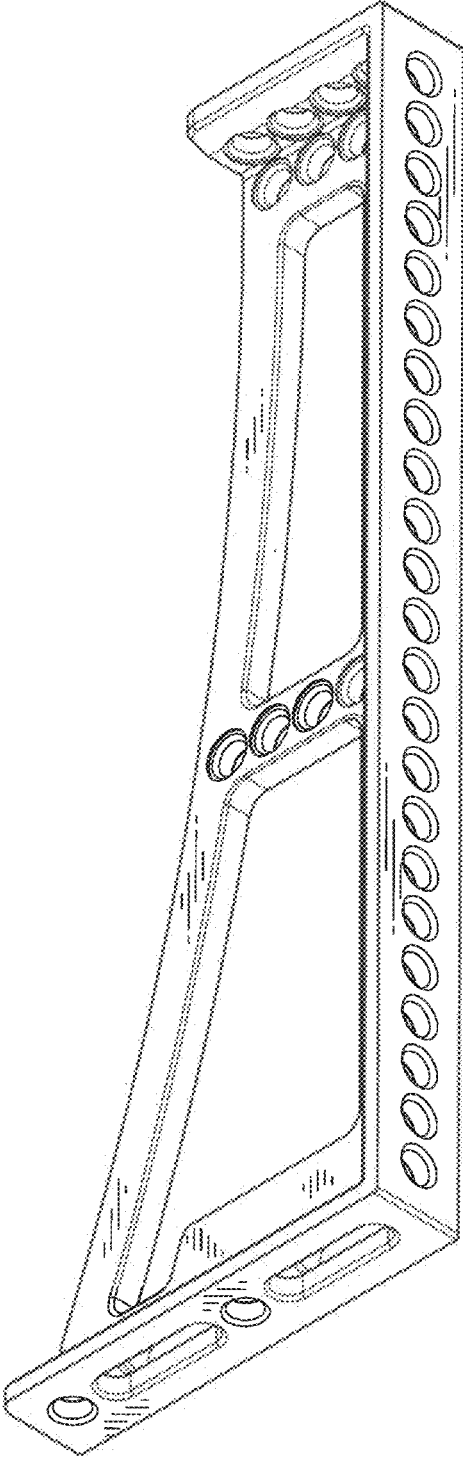

FIG. 10

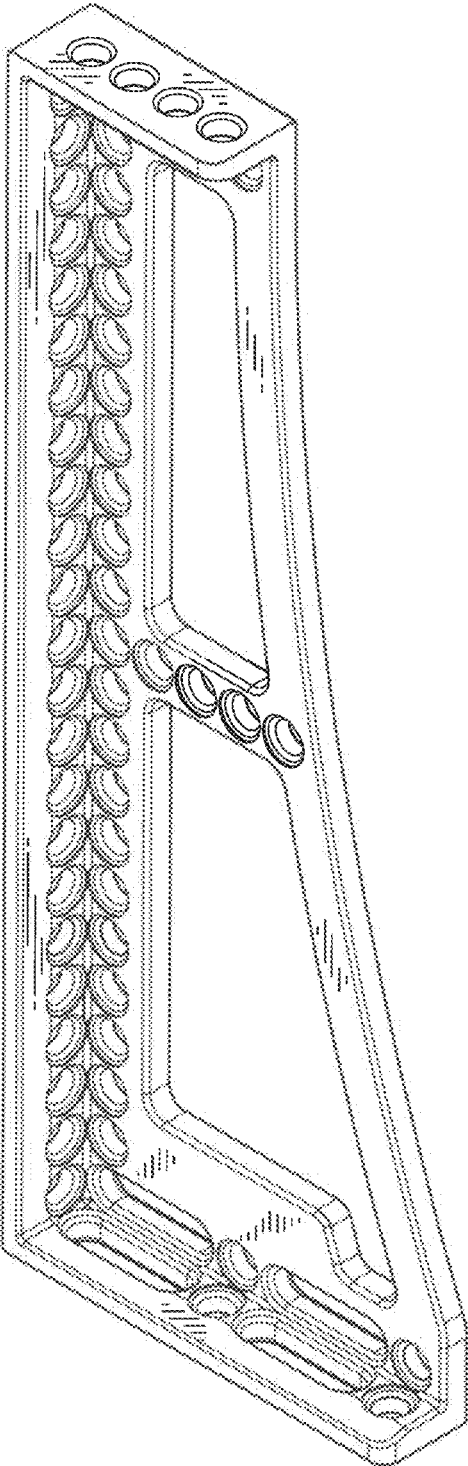

FIG. 11

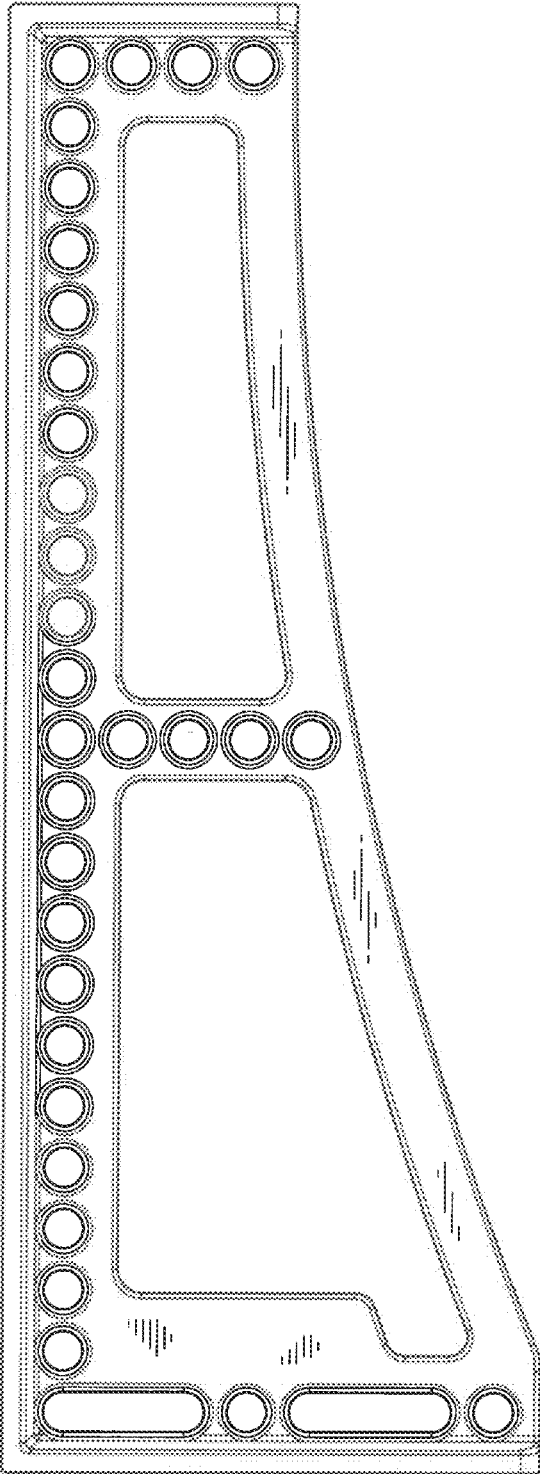

FIG. 12

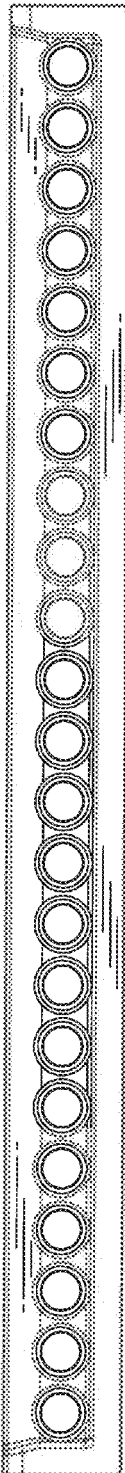

FIG. 13

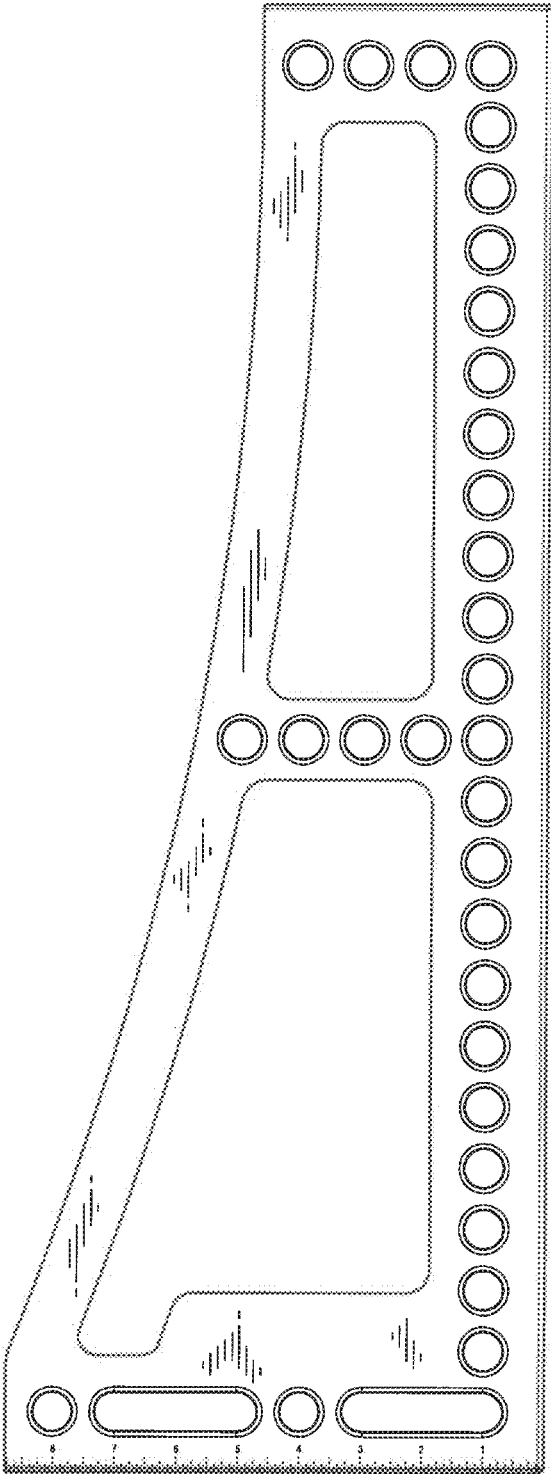

FIG. 14

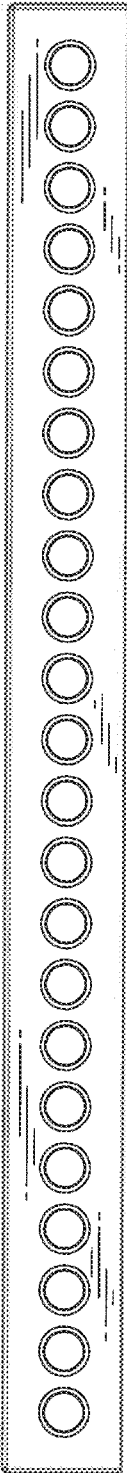

FIG. 15



FIG. 16



FIG. 17

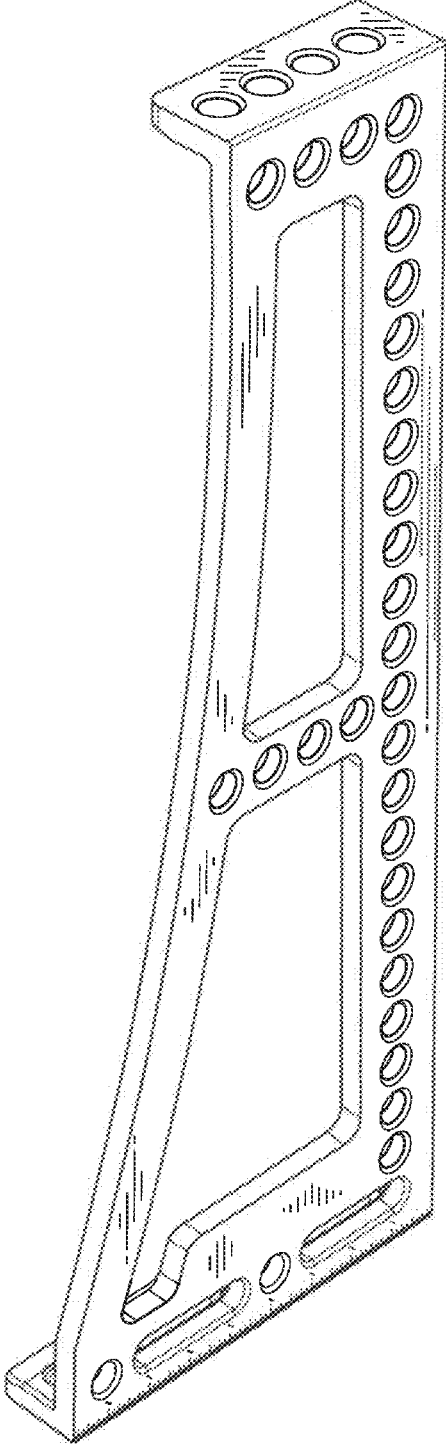

FIG. 18

