

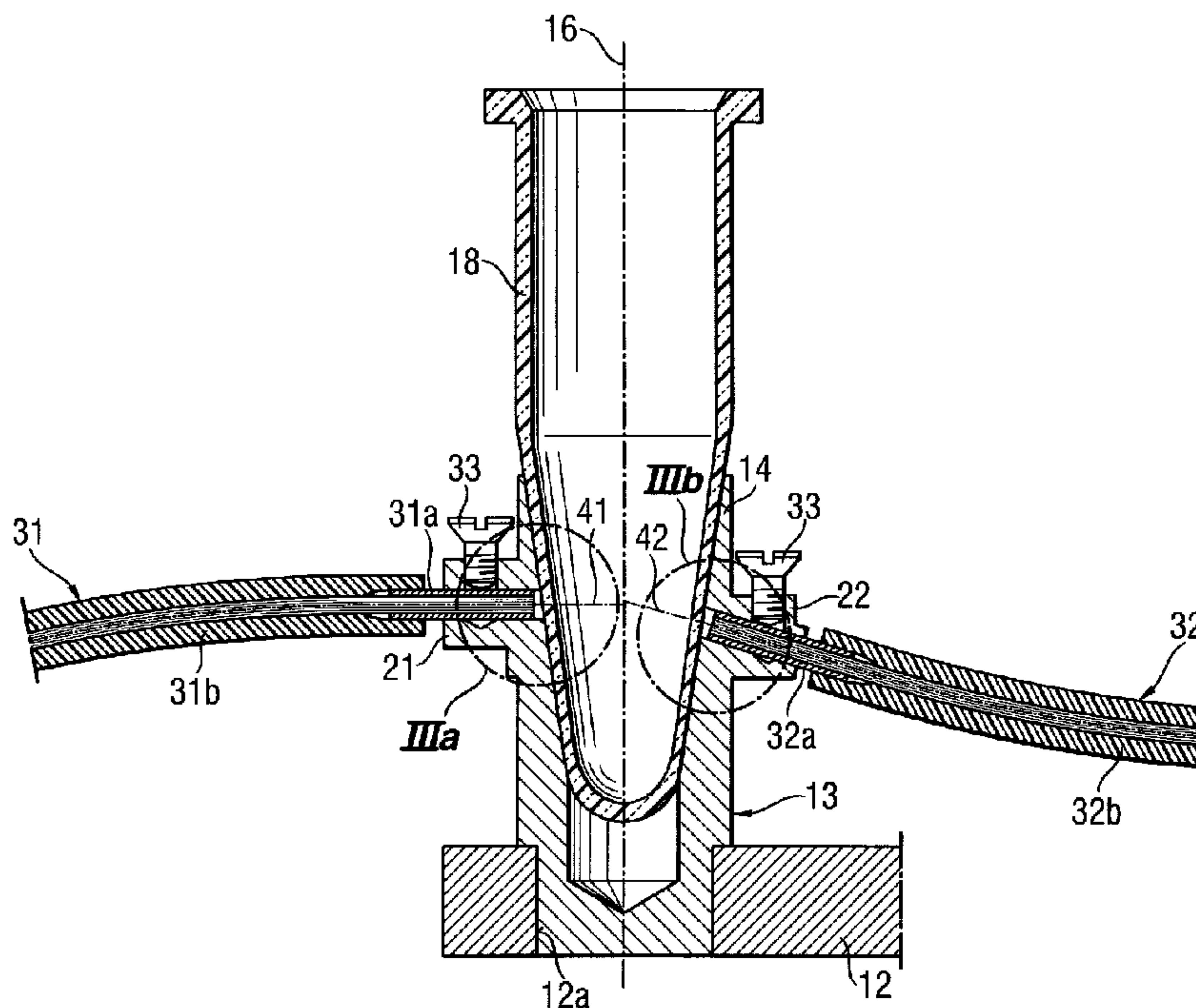

(22) Date de dépôt/Filing Date: 1999/03/29
(41) Mise à la disp. pub./Open to Public Insp.: 1999/11/01
(45) Date de délivrance/Issue Date: 2007/07/24
(30) Priorité/Priority: 1998/05/01 (EP98810394.1)

(51) Cl.Int./Int.Cl. *G01N 21/01* (2006.01),
B01L 7/00 (2006.01), *B01L 9/06* (2006.01),
G01N 21/64 (2006.01)
(72) Inventeurs/Inventors:
SCHMID, KARL, CH;
SCHNEEBELI, ROLF, CH
(73) Propriétaire/Owner:
F. HOFFMANN-LA ROCHE AG, CH
(74) Agent: GOWLING LAFLEUR HENDERSON LLP

(54) Titre : APPAREIL POUR LE MONITORAGE SIMULTANE DE REACTIONS AYANT LIEU DANS UNE PLURALITE DE CUVES A REACTION
(54) Title: APPARATUS FOR SIMULTANEOUSLY MONITORING REACTIONS TAKING PLACE IN A PLURALITY OF REACTION VESSELS



(57) **Abrégé/Abstract:**

The apparatus comprises a square, metallic vessel holder (11) with twenty-four chambers (13) arranged to smoothly take up in an upright position changeable, transparent reaction vessels used to carry biological reaction liquids of about 100 µl. At the side walls of the chambers (13) are arranged two connectors (21, 22) with associated boreholes. Within these holes are removably fixed first (32) and second optic fibers (31). These fibers are connected in such a manner, that the axial extensions of the fibers (31, 32) meet one another approximately at a same point of the chamber's axle, and in such a manner, that light escaping from the first fibers (32) cannot reach the second fibers (31) directly. The open ends of the fibers are connected to a common light source and individually to associated light receivers, respectively.

Abstract

The apparatus comprises a square, metallic vessel holder (11) with twenty-four chambers (13) arranged to smoothly
5 take up in an upright position changeable, transparent reaction vessels used to carry biological reaction liquids of about 100 μ l. At the side walls of the chambers (13) are arranged two connectors (21, 22) with associated boreholes. Within these holes are removably fixed first (32) and second
10 optic fibers (31). These fibers are connected in such a manner, that the axial extensions of the fibers (31, 32) meet one another approximately at a same point of the chamber's axle, and in such a manner, that light escaping from the first fibers (32) cannot reach the second fibers
15 (31) directly. The open ends of the fibers are connected to a common light source and individually to associated light receivers, respectively.

- - - - -

20

(Figure 1)

- 1 -

APPARATUS FOR SIMULTANEOUSLY MONITORING REACTIONS TAKING PLACE IN A PLURALITY OF REACTION VESSELS

The invention concerns an apparatus for simultaneously
5 monitoring reactions taking place in a plurality of reaction vessels, said apparatus comprising a metallic vessel holder with a plurality of chambers, the side wall of each of these chambers being formed to smoothly take up in an upright position a removable and transparent reaction vessel.

10

The inventions concerns in particular an apparatus of the above kind wherein the monitoring is carried out by measuring fluorescence light emitted by sample-reagent mixtures when they are excited by light provided by a
15 suitable light source, e.g. light of short wave-length.

An apparatus for the automatic execution of temperature cycles is known from EP 0 642 831 A1. This apparatus comprises a circular holder for twelve reaction vessels,
20 each of these vessels containing sample-reagent liquid mixtures of about 100 μ l. The holder is metallic and allows fast transmission of the different temperatures of the cycles from a controlled Peltier element to said mixtures.

25 A system for real time detection of nucleic acid amplification products is known from WO 95/30139 A1. This system allows to carry out fluorescence-based measurements on a plurality of sample-reagent liquid mixtures within small vessels at different, varying temperatures. The
30 excitation light arrives the vessels from the top side via a fiber optic and a focal lens. The fluorescent light is collected via the same way in opposite direction and is transmitted to a centralized optical separation and analyses component.

35

- 2 -

There are important disadvantages of the described devices. With the circular array of vessels disclosed by EP 0 642 831 A1 only a relatively low number of vessels can be positioned on a single Peltier element. Therefore, only a
5 small part of the area available on a Peltier element for thermal cycling of such vessels is used.

In order to carry out temperature cycles on a high number of reaction vessels arranged in a circle, it would be necessary
10 to use more than one Peltier element for cooling and heating. This is not desirable because Peltier elements are rather expensive. In the apparatus disclosed by WO 95 /30139 the excitation light path and the fluorescence light path are close to each other, and this increases the possibility
15 of the possibility of undesirable interferences.

Therefore, with the structure of the above-mentioned known devices it is not possible to provide a very compact array of reaction vessels which is suitable for performing thermal
20 cycling of a plurality of sample-reagent mixtures contained in reaction vessels positioned on a thermal block.

The aim of the invention is therefore to provide an apparatus of the above-mentioned type which comprises a very
25 compact array of reaction vessels, which is suitable for performing an efficient thermal cycling of the sample-reagent mixtures contained in a plurality of reaction vessels, and which allows optical real time measurements. A particular aim of the invention is to provide an apparatus
30 in which thermal cycling of a larger number of reaction vessels using a single Peltier element.

According to the invention this aim is attained with an apparatus which comprises

- 3 -

- a plurality of first optic fiber light guides, each of which connects the inside of the side wall of one of said chambers with a light source, and
 - 5 - a plurality of second optic fiber light guides, each of which connects the inside of the side wall of one of said chambers with a light receiver,
 - wherein in each of said chambers the axial extensions of optic fiber light guides connected to the chamber meet one another approximately at a same point of the
 - 10 longitudinal axis of said chamber, and in such a manner, that light escaping from one of said light guides is not able to reach the other light guide connected to said chamber.
- 15 A main advantage of the apparatus according to the invention is that it comprises a very compact array of reaction vessels and which is therefore suitable for performing efficient thermal cycling of said sample-reagent mixtures contained in said reaction vessels. A further advantage of
- 20 the apparatus according to the invention is that in spite of the short distance between neighbor reaction vessels and of short distance between excitation light and fluorescence light fibers optically connected to each reaction vessel, a stray light emanating from an excitation beam directed to a
- 25 sample-reagent mixture in a reaction vessel cannot interfere with measurement of fluorescence light emitted from said sample-reagent mixture. The apparatus according to the invention is therefore in particular suitable for monitoring simultaneously reactions taking place in a plurality of
- 30 reaction vessels by means of fluorescence measurements which are carried out at any time, especially during thermal cycling of sample-reagent mixtures contained in said reaction vessels.

- 4 -

Preferred embodiments of the invention are characterized by the features defined by claims 2 to 11.

For a better understanding of the invention, preferred
5 embodiments thereof are described in more detail hereinafter with reference to the accompanying drawings.

Figure 1 shows a top view of a vessel holder,

10 Figure 2 shows a vertical cross-section through the vessel holder shown by Fig. 1,

Figure 3 shows an enlarged representation of a vertical
15 cross-section through one of the chambers of the vessel holder and through two planes which form an angle of 90° and pass through the centers of connectors like 21 and 22 in Fig. 1.

Figures 3a and 3b show enlarged representations of the areas
20 IIIa respectively IIIb in Figure 3.

Figure 4 shows a second top view of vessel holder.

Figure 1 shows a top view on a vessel holder 11, Figure 2 a
25 vertical cross-section through the vessel holder, both Figures being enlarged by a factor of about 2 with respect to the real size of the objects shown. The holder 11 comprises a quadratic ground plate 12 the bottom side of which lies on a plane. The upper part of plate 12 contains a
30 matrix-like array of twenty-four chambers 13. Each of these chambers has upright side walls 14 and a circular cross-section in a plane perpendicular to its longitudinal axis. The outer side of side walls 14 is of cylindrical shape; the inner side 15 of side walls 14 defines a chamber the cross-
35 section of which diminishes towards the bottom of the

- 5 -

chamber. Each of the chambers 13 is apt to receive the lower part of a commercially available, removable reaction vessel 18 suitable for receiving about 100 μ l of liquid. The lower part of one of such a reaction vessel has a shape which
5 smoothly fits into the inner side of a chamber 13 when the vessel is positioned in the latter chamber.

The flat bottom side of the ground plate 12 is arranged on a single Peltier element 19 used for heating and cooling of
10 the vessel holder 11 and the reaction vessels 18 inserted in the chambers 13 of ground plate 12. For good thermal conduction the vessel holder 11 is metallic, and it is preferably made of aluminum. In the following description the term optic fiber is used to designate an optic fiber
15 light guide which is not necessarily a single fiber, but which is preferably a bundle of thin optic fibers, e.g. a bundle of about 50 to 100 optic fibers, such a bundle having a diameter of about 0.5 mm.

20 At each chamber wall 14 are arranged two connectors 21, 22. These connectors are used to fix optic fibers 31, 32 and are arranged under an angle of about 90 degrees, seen in top view.

25 Figure 3 shows an enlarged representation, by a factor of about 5 : 1, of a vertical cross-section of chamber 13 and of optic fiber light guides connected thereto. This is a cross-section along two different planes passing along the longitudinal axis 16 of chamber 13. One of this planes
30 passes through the axis of a connector like 21 in Fig. 1 and the other plane passes through the axis of a connector like 22 in Fig. 1.

As shown by Fig. 3, the ground plate 12 has boreholes 12a,
35 into which the circular chamber 13 is inserted and fixed,

- 6 -

e.g. by pressing or soldering, the base plane afterwards being polished. When a reaction vessel 18 is inserted in a chamber 13, the lower part of vessel 18 smoothly fits into the inner side of side walls 14 of chamber 13. As shown by Fig. 3a, the side wall 14 has a first connector 21 which has a horizontal borehole 21a.

An end part of an optic fiber 31, which comprises a bundle of optic fibers having a bundle diameter of about 0.5 mm and which is sheathed by a flexible cover 31b with an outer diameter of about 1.5 mm is inserted into borehole 21a of connector 21. The end part of optic fiber 31 which is inserted into borehole 21a is surrounded by a rigid guiding tube 31a. One end of this tube is shoved under the flexible cover 31b and its other end is fixed by a screw 33 in such a way, that the open end of the fiber 31 is close to, but is spaced from the wall of the reaction vessel 18. The front end 31c of fiber 31 is a polished surface which lies in a plane which is parallel to the longitudinal axis 16 of chamber 13. The axial extension 41 of the fiber 31 meets the longitudinal axis 16 of the chamber 13 or the vessel 18, respectively. The space between the front end 31c and the wall of the vessel 18 is established by help of a ball gauge.

25

As shown by Fig. 3, connector 22 is arranged at the side wall 14 a bit lower than connector 21. Connector bore hole 22a of connector 22 is inclined with respect to the longitudinal axis 16 of the chamber and the axial extension 42 of bore hole 22a meets the longitudinal axis 16 of the chamber 13 nearly at the same point as the extension 41 of bore hole 21a.

An end part of an optic fiber 32, which comprises a bundle of optic fibers having a bundle diameter of about 0.5 mm and

35

- 7 -

which is sheathed by a flexible cover 32b with an outer diameter of about 1.5 mm is inserted into borehole 22a of connector 22. The end part of optic fiber 32 which is inserted into borehole 22a is surrounded by a rigid guiding tube 32a. One end of this tube is shoved under the flexible cover 32b and its other end is fixed by a screw 33 in such a way, that the open end of the fiber 32 is close to, but is spaced from the wall of the reaction vessel 18. The front end 32.3 of fiber 32 is a polished surface which lies in a plane which is inclined with respect to the longitudinal axis 16 of chamber 13. The axial extension 42 of the fiber 32 meets the longitudinal axis 16 of the chamber 13 or the vessel 18, respectively. The space between the front end 32.3 and the wall of the vessel 18 is established by help of a ball gauge.

As shown by Fig. 3, the axial extensions 41, 42 do not meet exactly at the same point of the axis 16. But when there is a reaction liquid within vessel 18, refraction of the light beams transmitted by optical fibers 31 and 32 will cause that these beams meet at a point.

Further the construction is such that the angle between axial extension 41 and the portion of side wall of vessel 18 which is adjacent to connector 21 is equal to the angle between axial extension 42 and the portion of side wall of vessel 18 which is adjacent to connector 22. Therefore, the light beams transmitted by optical fibers 31 and 32 find the same geometric conditions.

To prevent undesirable light reflections the whole holder 11 including the chambers 13 are colored black, e.g. by anodic coating.

- 8 -

As shown by Fig. 4, all optic fibers 31 are bundled and held together by e. g. a helical tape to form a bundle 51, and all optic fibers 32 are also bundled and held together by e. g. a helical tape to form a bundle 52. Bundles 51 and 52
5 extend in the same direction. It is important that all the fibers 31 and all the fibers 32 have about the same length and that none of the fibers 31, 32 is bent sharply. The minimum radius of curvature of fibers like 31 and 32 which are each a bundle of thin optic fibers is much smaller than
10 the radius of curvature of a single optic fiber having the same total cross-section. By using optic fiber bundles 31, 32 it is thus possible to make bows having a small radius of curvature and therefore to accommodate many fibers in a relatively small space.

15

As shown by Figures 1 and 4, each fiber 31, 32 passes at most two chambers 13 on its way from its connector 21 respectively 22 to the space outside the area where the vessel holder 11 is located (Figure 1). This is made
20 possible on the one hand by the arrangement of the chambers 13 and their connectors 21, 22 looking into outside direction as given by Figure 1, and on the other hand by the above described construction of connectors 21, 22 and their associated boreholes 21a, 22a which lead fibers 31, 32 into
25 two different planes between the chambers 13. These arrangement allow crossing of fibers 31 with fibers 32 and vice versa.

As a whole the structure comprising a vessel holder 11 with
30 a side length of about 4 cm and with a distance of 9 mm between longitudinal axis 16 of adjacent chambers 13 is very compact. A measure of the compactness of this structure is the ratio of the cross-section surface of all reaction vessels 18 as shown by the top view according to Figure 1 to

- 9 -

the surface available on the vessel holder 11 for positioning the vessels 18. This ratio is larger than 0.6. The structure just mentioned allows to guarantee uniform equal temperature all over the holder 11. For thermal
5 cycling this temperature is modified by electrical control of Peltier element 19.

The vessel holder 11 is used within an apparatus for monitoring reactions of e. g. liquid biological probes.
10 These liquid probes with a volume of e. g. 100 μ l are filled into the reaction vessels 18 fixed in the chambers 13. This is done automatically with help of e. g. a pipetting means. The reactions take place within the reaction vessels 18 and require cyclical temperature changes. At any time the optic
15 fibers 32 allow to transmit the excitation light of a common light source, e. g. a halogen lamp with interference filter to get monochromatic light, to each of the chambers 13. This light escapes the front ends 32.3 of the fibers 32, passes through the transparent walls of the vessels 18 and reaches
20 the liquid sample-reagent mixture, where the light beam undergo refracton. The sample-reagent mixture contains fluorophores which upon excitation emit more or less fluorescence light in function of the result of the reaction. The fluorescence light is collected by the second
25 optic fibers 31 and transmitted to 24 individual light receivers not shown, e. g. photo diodes. The receiving signals of the light receivers are then the measured for the individual reactions to be monitored.

30 It is important, that the ends of both fibers 31 and 32 are not optically connected with each other. With the above described structure, fibers 31 only collect fluorescence light to be monitored. Stray light reflected at the wall of the reaction vessels 18, at the upper meniscus surface of
35 and/or at particles inside the liquid probes does not reach

- 10 -

the light receiver and has therefore no influence on the output signals thereof. The given geometry of the upright standing vessels 18, the conical wall of the vessels 18 and the horizontal respectively not horizontal direction of the axial extensions 41, 42 result in a minimum of stray light. Foam at the surface of the liquid probes or condensations inside the vessel 18 have no influence. Day light may be minimized by day light filters or better by surrounding the vessel holder 11 by a light tight box.

10

There are a lot of variants within the general idea of the invention. The most important variants will be nominated in the following:

- 15 - There may be a plurality of more or less than 24 chambers 13 at the vessel holder 11.
- The vessel holder 11 can be formed as a square, a rectangular, a circle, etc. The chambers 13 may be arranged matrix-like with lines and columns rectangular or staggered.
- 20
- The angle between the both fiber connectors 21, 22 can be of 90 degrees as shown, but the angle may be larger or less. Generally, the angle must be as small that no light escaping the optic fiber 32 will be able to directly reach the other fiber 31 receiving light from the liquid probe.
- 25
- The boreholes 21a, 22a of the connectors 21, 22 both may be not horizontally oriented, e.g. the first leading upwards, the second leading downwards, the axial extensions 41, 42 meeting at a same point of the longitudinal axis 16 of the chamber 13 or nearby.
- 30

- 11 -

- The optic fibers 31, 32 may be fixed inside the boreholes 21a, 22a otherwise than by the screws 33 shown in Figure 3, e.g. by gluing. But the screws 33 have the advantage that the fibers are exchangeable easily.

5

- The dimensions of the chambers 13 and the reaction vessels 18 may be variable. Further, two or more different sizes may be used at the same vessel holder 11.

10 Summarizing, an apparatus has been described for monitoring reactions at any time, simultaneously and using light, said apparatus comprising a metallic vessel holder 11 with a plurality of chambers 13, the side walls 14 of these chambers 13 being formed to smoothly take up in an upright
15 position independent, changeable, transparent and conical reaction vessels 18, inside which vessels 18 said reactions take place, wherein said apparatus comprises first optic fibers 32 connecting the insides of said side walls 14 of all said chambers 13 with a light source, and second optic
20 fibers 31 connecting said insides of said side walls 14 of all said chambers 13 with at least one light receiver, wherein said first 32 and said second fibers 31 connecting said insides in such a manner, that the axial extensions 42, 41 of said fibers 32, 31 meet one another approximately at a
25 same point of the longitudinal axis 16 of said chambers 13, and in such a manner, that light escaping from said first fibers 32 is not able to directly reach said second fibers 31.

30

- - - - -

Claims

1. An apparatus for simultaneously monitoring reactions
taking place in a plurality of reaction vessels, said
5 apparatus comprising:

a metallic vessel holder having a plurality of chambers with
the side wall of each of said chambers being formed to hold
in an upright position a removable and transparent reaction
10 vessel, wherein said side wall of each of said chambers
comprises two connectors with associated boreholes, said
connectors having axes which, when seen from a top view of
said chamber, form an angle, the longitudinal axis of one of
said boreholes being perpendicular to the longitudinal axis
15 of said chamber and the longitudinal axis of the other of
said boreholes being inclined with respect to the
longitudinal axis of said chamber, the axial extensions of
said boreholes meeting one another approximately at the same
point of the longitudinal axis of said chamber;

20 a plurality of first optic fiber light guides, wherein each
of said optic fiber light guides connects the inside of the
side wall of one of said chambers with a light source;

25 a plurality of second optic fiber light guides, wherein each
of said optic fiber light guides connects the inside of the
side wall of one of said chambers with a light receiver; and

30 said boreholes bearing the endpieces of said second and said
first optic fiber light guides connect to said chambers,
respectively.

35 2. An apparatus according to claim 1, wherein each of said
plurality of first optic fiber light guides and each of said
plurality of second optic fiber light guides are each a
bundle of about 50 to 100 parallel fibers with each bundle
having a diameter of about 0.5 mm.

3. An apparatus according to claim 2, wherein said plurality

of said first optic fiber light guides and said plurality of said second optic-fibers are combined to form two independent bundles so that none of said optic fiber light guides passes at the side of more than two of said chambers and that between said chambers a segment of a first optic fiber light guide is arranged in a first plane and a segment of a second optic fiber light guide is arranged in a second plane which lies above said first plane.

5
10 4. An apparatus according to claim 1, wherein said vessel holder comprises a square ground plate carrying twenty-four chambers arranged in a matrix-like array.

15 5. An apparatus according to claim 4, wherein said ground plate is of aluminum having a plane bottom side being in contact with a single Peltier element.

20 6. An apparatus according to claim 4, wherein the distance between the longitudinal axis of the neighboring chambers is about 9 mm.

25 7. An apparatus according to claim 4, wherein the ratio of the cross-section surface of said chambers to the surface available for positioning said reaction vessels is larger than 0.6 mm.

30 8. An apparatus according to claim 4, wherein said plurality of said first optic fiber light guides and said plurality of said second optic fibers are combined to form two independent bundles so that none of said optic fiber light-guides passes at the side of more than two of said chambers and that between said chambers a segment of a first optic fiber light guide is arranged in a first plane and a segment of a second optic fiber light guide is arranged in a second plane which lies above said first plane.

35 9. An apparatus according to claim 1, wherein said endpieces are removably positioned within said boreholes and held therein by means of screws.

10. An apparatus according to claim 1, wherein said
endpieces are fixed within said boreholes so that the front
ends of the optic fibers are close to but spaced from the
5 side wall of the reaction vessel inserted into said chamber.

11. An apparatus according to claim 1, wherein said
plurality of said first optic fiber light guides and said
plurality of said second optic fibers are combined to form
10 two independent bundles so that none of said optic fiber
light guides passes at the side of more than two of said
chambers and that between said chambers a segment of a first
optic fiber light guide is arranged in a first plane and a
segment of a second optic fiber light guide is arranged in a
15 second plane which lies above said first plane.

12. An apparatus according to claim 11, wherein said bundle
of said plurality of first optic fiber light guides is
connected to a single light source and each of said
20 plurality of second optic fiber light guides which form the
second bundle optic fiber light guides are connected
individually to a light receiver.

13. An apparatus according to claim 1 wherein said axes of
25 said connectors form an angle of about 90 degrees.

14. An apparatus for simultaneously monitoring reactions
taking place in a plurality of reaction vessels, said
apparatus comprising:

30 a metallic vessel holder having a plurality of chambers with
the side wall of each of said chambers being formed to hold
in an upright position a removable and transparent reaction
vessel;

35 a plurality of first optic fiber light guides, each of which
ate a bundle of about 50 to 100 parallel fibers with each
bundle having a diameter of about 0.5 mm, and each of said
first fiber light guides connects the inside of the side

wall of one of said chambers with a light source;

5 a plurality of second optic fiber light guides, each of which are a bundle of about 50 to 100 parallel fibers with each bundle having a diameter of about 0.5 mm, and each of said second optic fiber light guides connects the inside of the side wall of one of said chambers with a light receiver;

10 wherein in each of said chambers the axial extensions of optic fiber light guides connected to the chamber meet one another approximately at a same point of the longitudinal axis of said chamber and such that light escaping from one of said light guides is not able to reach the other light guide connected to said chamber; and

15 wherein said side wall of each of said chambers comprises two connectors with associated boreholes, said connectors having axes which, when seen from a top view of said chamber, form an angle of about 90 degrees, the longitudinal axis of one of said boreholes being perpendicular to the longitudinal axis of said chamber and the longitudinal axis of the other of said boreholes being inclined with respect to the longitudinal axis of said chamber, the axial extensions of said boreholes meeting one another

20 approximately at a point of the longitudinal axis of said chamber and said boreholes bearing the endpieces of said second and said first optic fiber light guide connected to the chamber, respectively.

25

Fig. 1

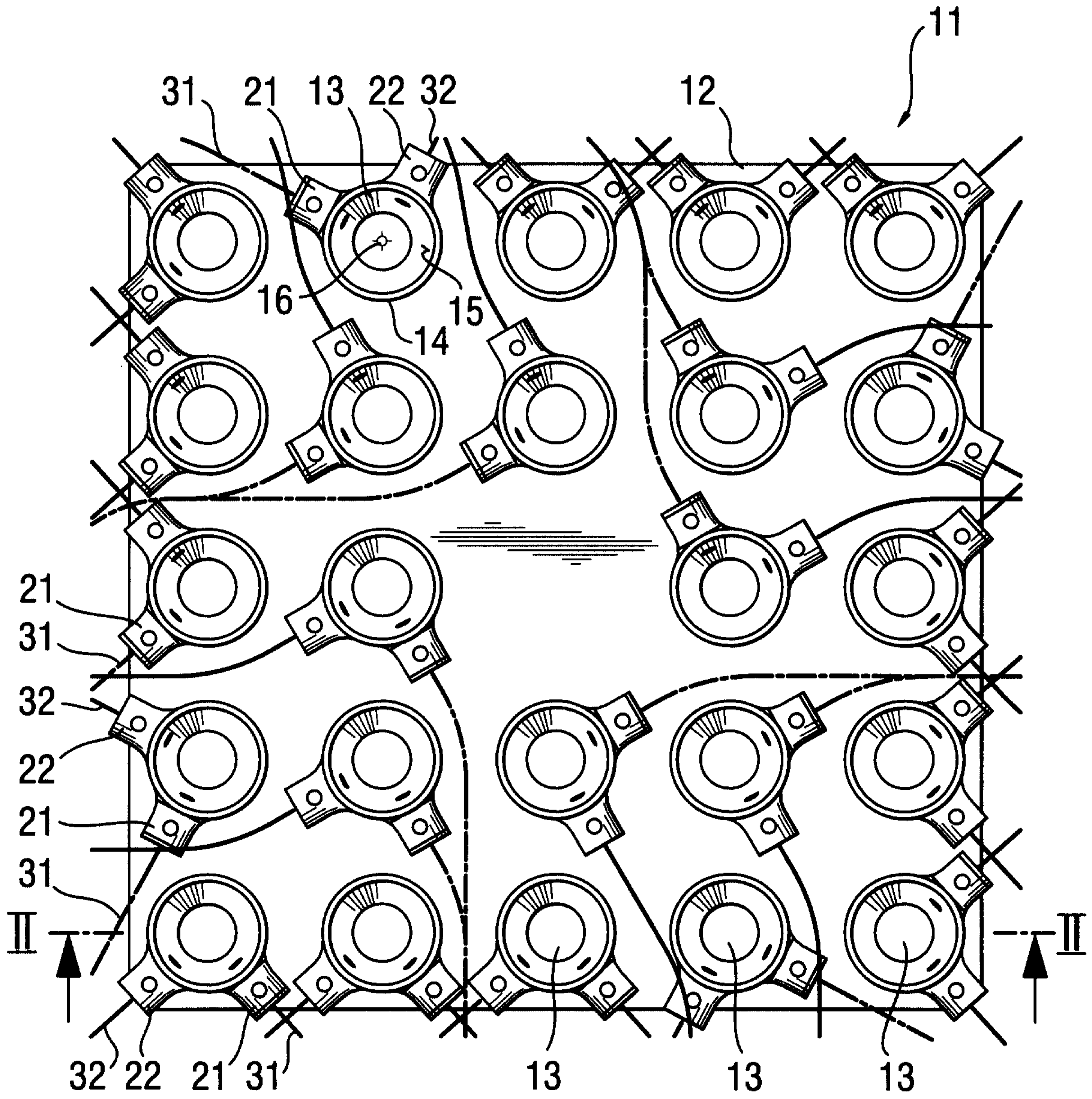

Fig. 2

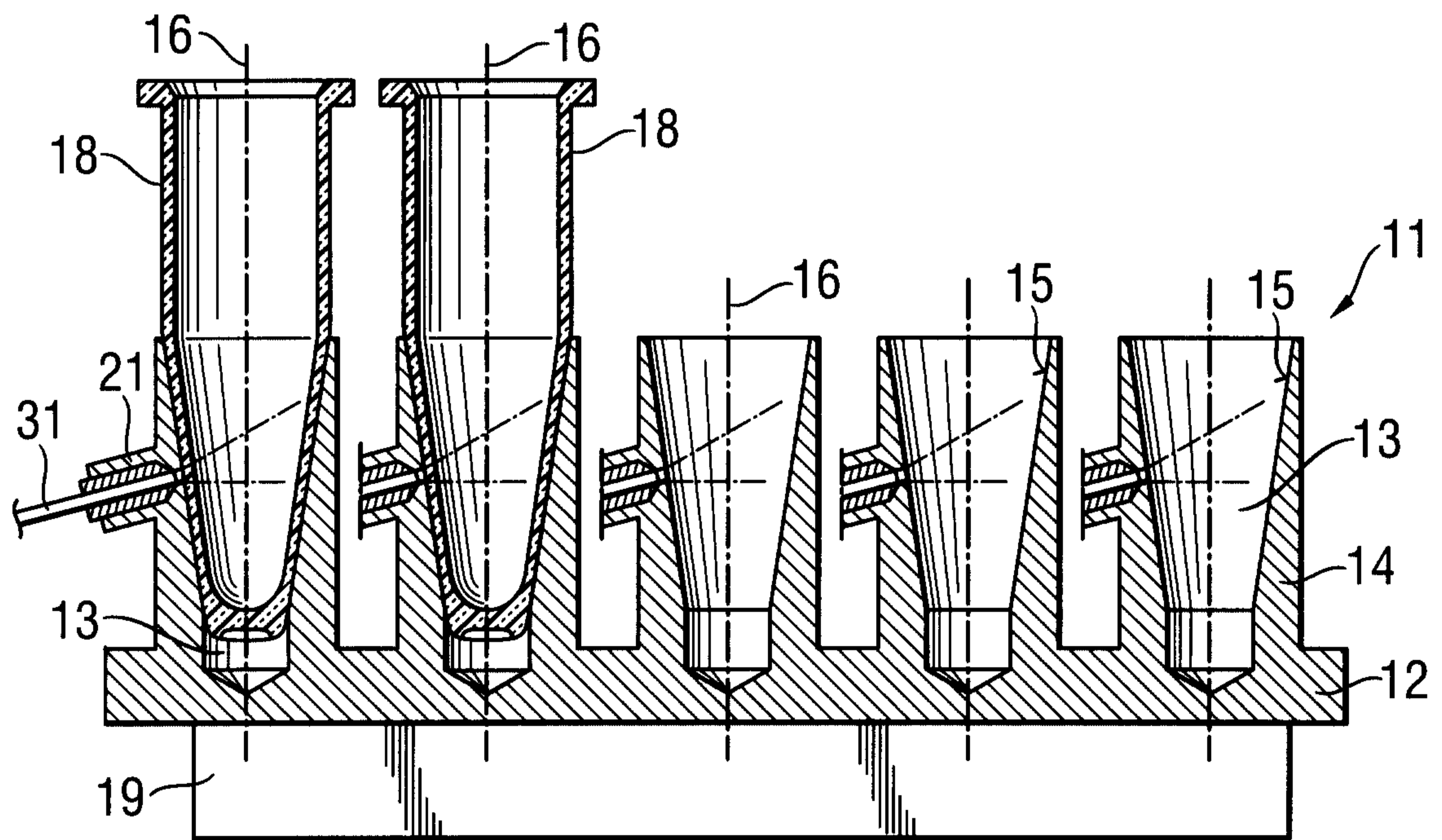

Fig. 3a

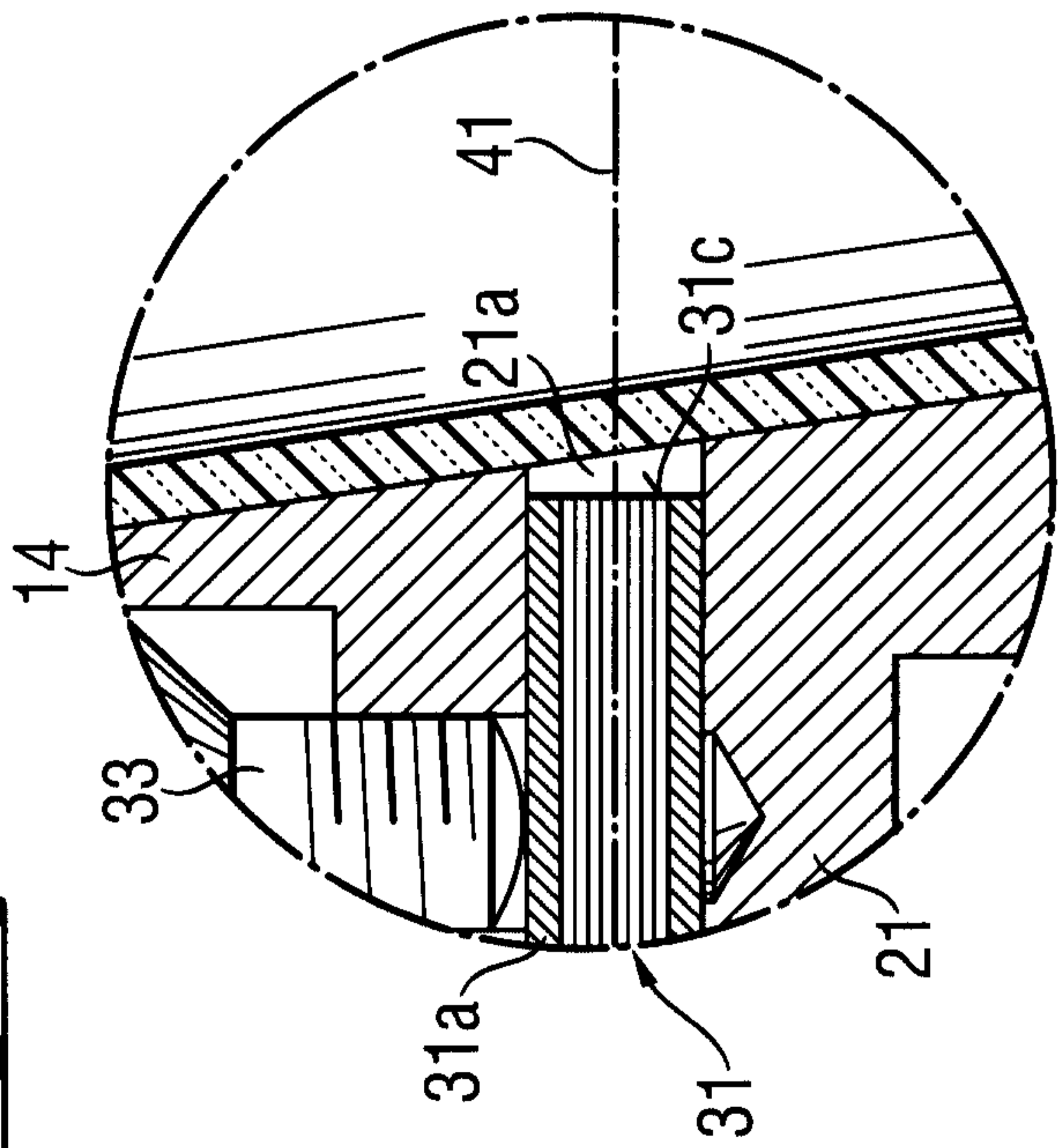

Fig. 3b

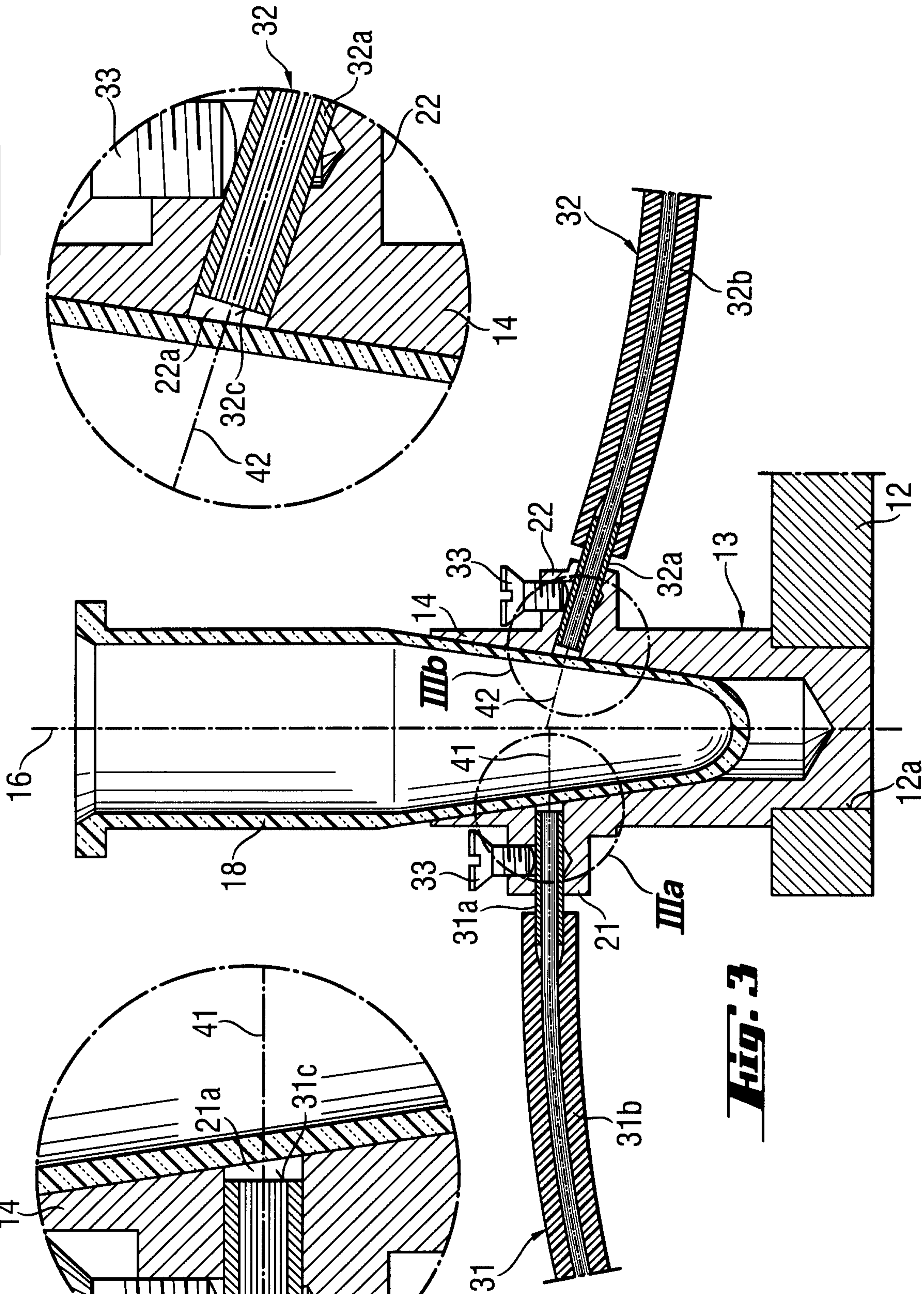

Fig. 3

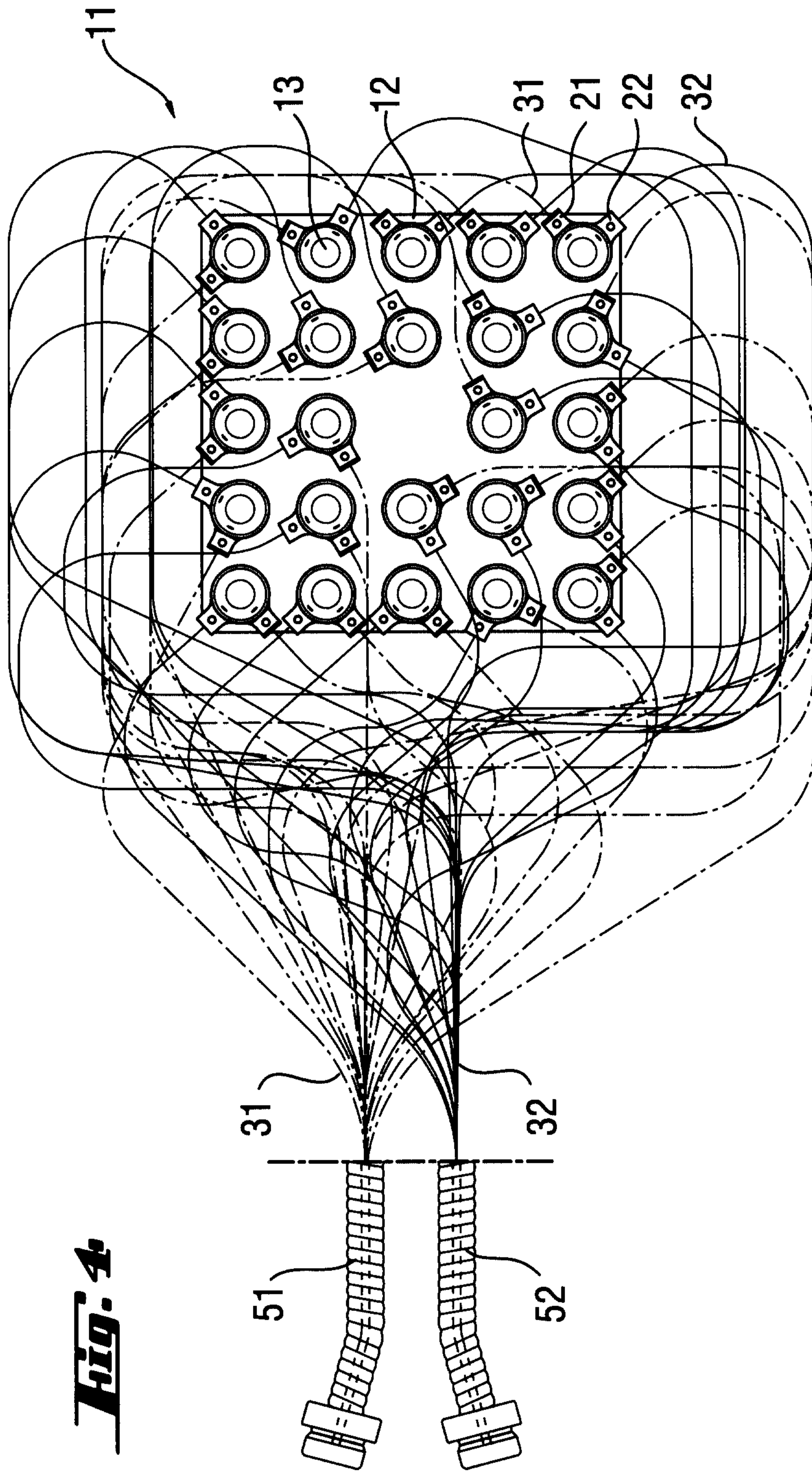

Fig. 4

