

(No Model.)

3 Sheets—Sheet 1.

A. S. OETZMANN.
MACHINE FOR THE MANUFACTURE OF COVERINGS FOR FLOORS OR
OTHER SURFACES.

No. 524,606.

Patented Aug. 14, 1894.

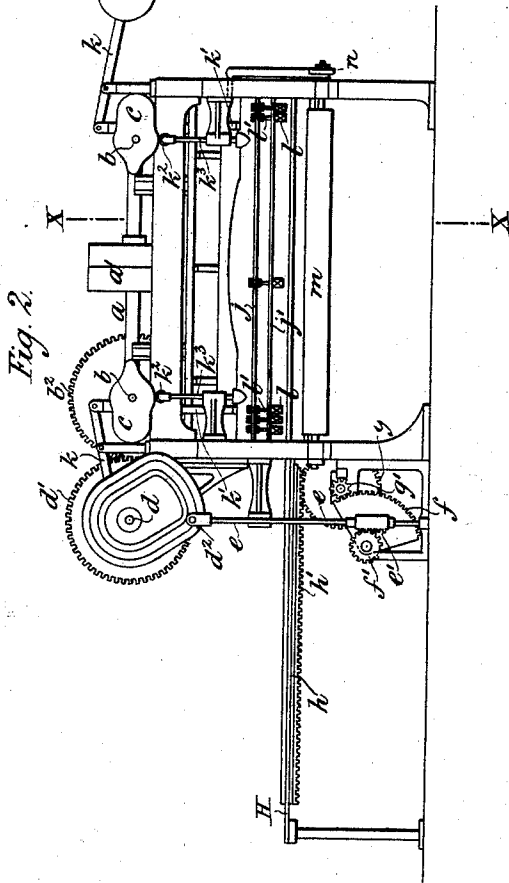

Fig. 2.

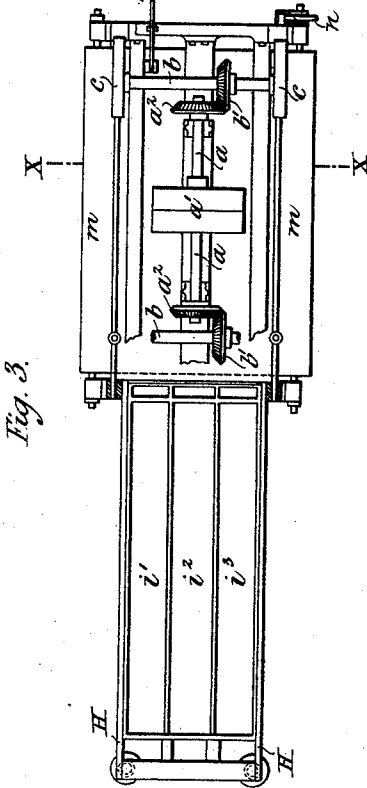

Fig. 3.

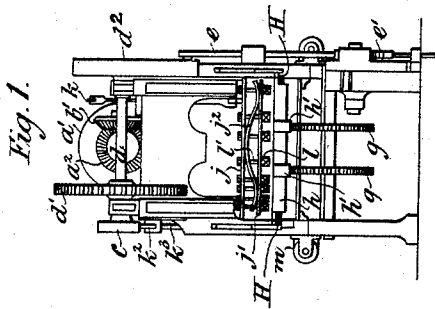

Fig. 1.

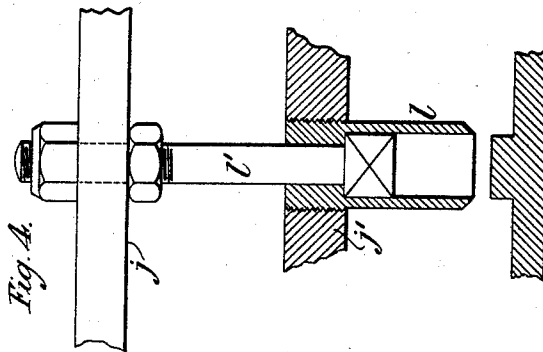

Fig. 4.

Witnesses
B. W. Miller
Guy E. Davis

Inventor
Arthur S. Oetzmann
By his Attorneys
Baldron Davidson Wright.

(No Model.)

3 Sheets—Sheet 2.

A. S. OETZMANN.
MACHINE FOR THE MANUFACTURE OF COVERINGS FOR FLOORS OR
OTHER SURFACES.

No. 524,606.

Patented Aug. 14, 1894.

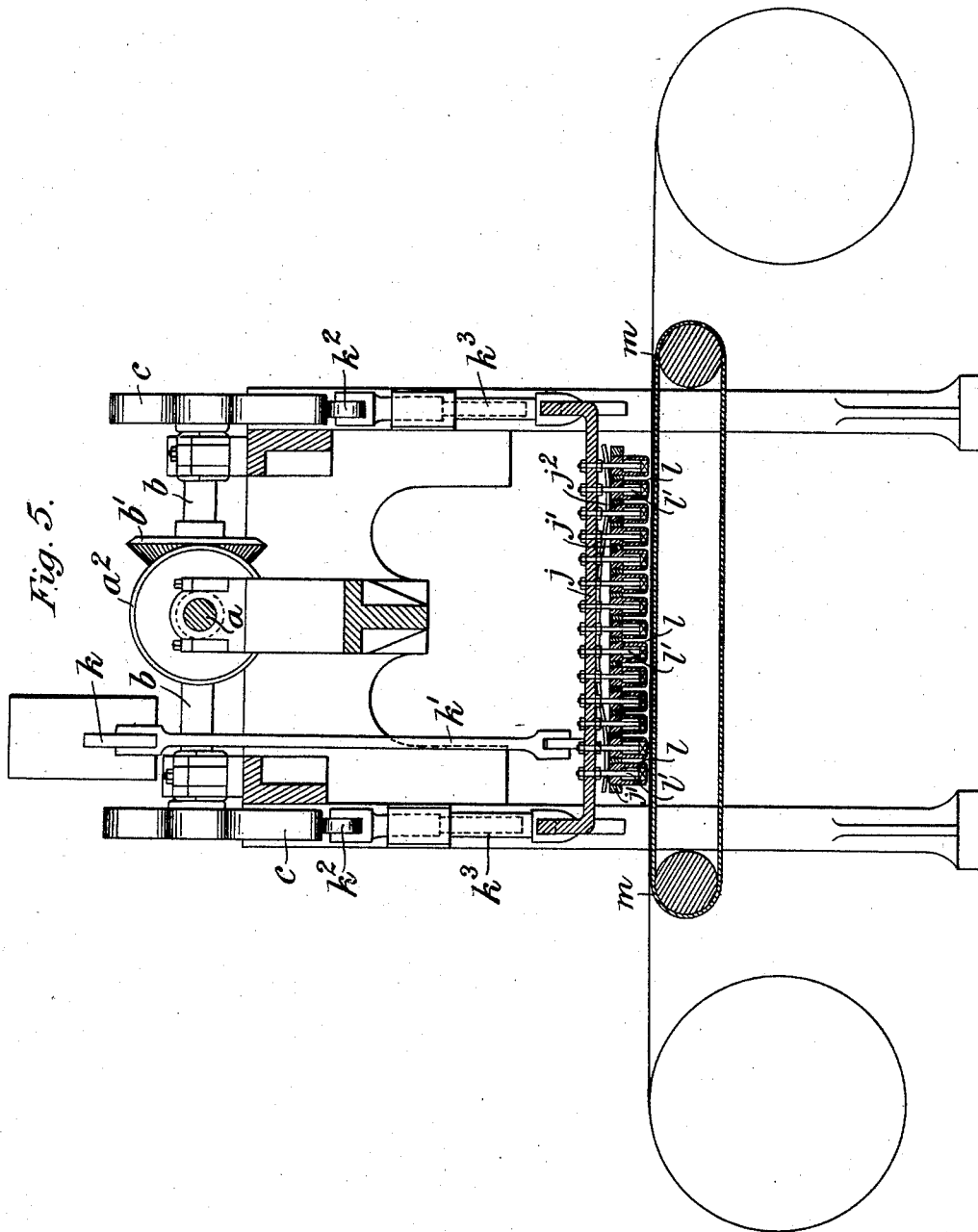

Witnesses
B. W. Miller
Ray E. Davis

Inventor
Arthur S. Oetzmann
By his Attorneys
Ballou Davidson & Wright

(No Model.)

3 Sheets—Sheet 3.

A. S. OETZMANN.

MACHINE FOR THE MANUFACTURE OF COVERINGS FOR FLOORS OR OTHER SURFACES.

No. 524,606.

Patented Aug. 14, 1894.

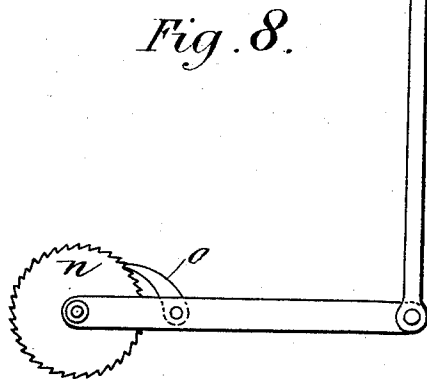
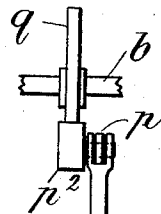
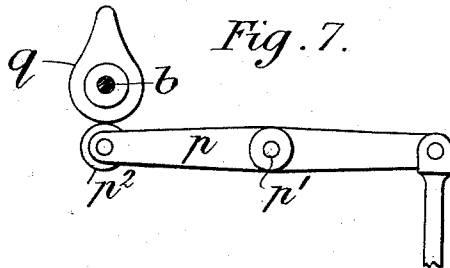
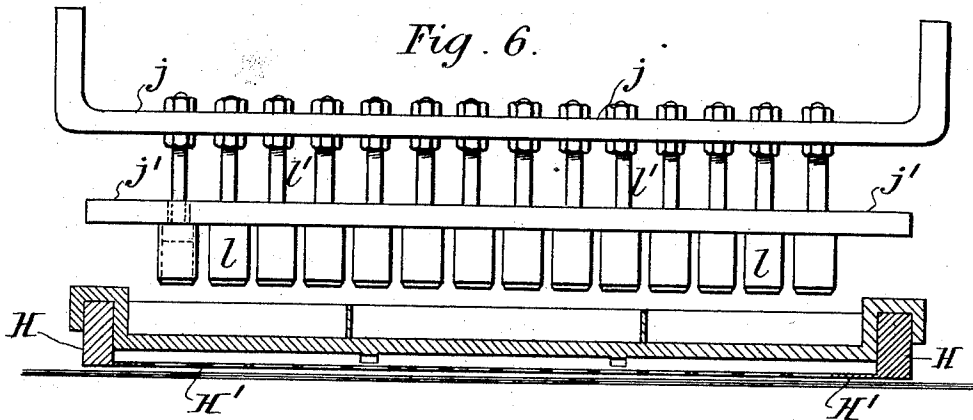

Witnesses.
B. W. Miller.
C. M. Brooke.

Inventor.
Arthur S. Oetzmann.
By his Attorney,
Paldon Davidson Wright

UNITED STATES PATENT OFFICE.

ARTHUR SIDNEY OETZMANN, OF LONDON, ENGLAND, ASSIGNOR TO THE
PATENT INLAID LINOLEUM COMPANY, LIMITED, OF SAME PLACE.

MACHINE FOR THE MANUFACTURE OF COVERINGS FOR FLOORS OR OTHER SURFACES.

SPECIFICATION forming part of Letters Patent No. 521,606, dated August 14, 1894.

Application filed April 11, 1894. Serial No. 507,100. (No model.) Patented in England October 14, 1892, No. 18,420; in France November 15, 1892, No. 225,678, and in Germany November 25, 1892, No. 72,687.

To all whom it may concern:

Be it known that I, ARTHUR SIDNEY OETZMANN, manufacturer, a subject of the Queen of Great Britain, residing at 67 to 79 Hampstead Road, London, in the county of Middlesex, England, have invented certain new and useful Machines for the Manufacture of Coverings for Floors and other Surfaces, (for which I have received Letters Patent in Great Britain, No. 18,420, dated October 14, 1892; in France, No. 225,678, dated November 15, 1892, and in Germany, No. 72,687, dated November 25, 1892,) of which the following is a specification.

The invention relates to the manufacture of coverings for floors and other surfaces by consolidating together measured quantities of the composition of which the upper surface of the fabric is to be composed the colors of the said measured quantities being such that the desired pattern is obtained. I employ a number of measures conforming to the shape of the desired pattern a separate set of measures being used for each color in the desired pattern; these measures are open at one end and have the other end closed by a sliding rod or plunger. Each set of measures has pressed into it at the mouths or open ends of the measures the proper quantity of material of its own particular color and the measures are then brought down onto a backing and the material is ejected from the measures onto the backing in position where it is required to form the finished fabric. The whole is then consolidated by heat and pressure.

I sometimes prefer to place one of the colors upon the backing in the ordinary manner and then form cavities in it by means of an embossing roller, the remaining colors being filled in by means of the measures.

Figure 1 is an end elevation; Fig. 2 a side elevation and Fig. 3 a plan of a machine constructed according to this invention. Fig. 4 is a vertical section to a larger scale of one of the measures with its plunger and the tray beneath it. Fig. 5 is a transverse section of the machine on the line X X Figs. 2 and 3 to

a larger scale, the molds being down. Fig. 6 is part of a similar section (to twice the scale of Fig. 5), the molds being raised. Figs. 7 and 8 are diagram views (to the same scale as Fig. 6) showing the method of actuating the roller *m*.

a is the main shaft of the machine driven by a belt passing over the pulley *a'* upon it. This shaft has at each end a beveled pinion *a²* gearing with beveled pinions *b'* upon the cross shafts *b* to which are also fixed cams *c*. One of the shafts *b* also has fixed to it a spur wheel *b²* gearing with a spur wheel *d'* on the shaft *d* to which is fixed a cam *d²* giving an up and down motion to the rod *e* at whose lower end is fixed the rack *e'* gearing with the pinion *f'* upon the quadrant *f* which in its turn gears with the pinion *g'* upon the axis of the wheels *g* the latter gearing with the racks *h'* on the under side of the table *h* upon which are three trays *i' i² i³* (which trays may have raised portions as shown in Fig. 4 exactly corresponding in contour to the inside of the measures *l* and engaging with them during part of the operation of the machine) containing linoleum material or other compositions of different colors. The table *h* is free to slide on guide bars *H*, to the right hand end of which is fixed the guard plate *H'*, (Fig. 6.)

j j' are two sliding tables the table *j'* being suspended by the plungers *l'* from the table *j*. The table *j* is supported by rods *k'* from the levers and counterbalance weights *k* which tend to raise it. It is however periodically depressed by the cams *c* which act on rollers *k²* on rods *k³* fixed to the upper side of the table *j*. This table carries on its under side the plungers *l'* of the measures *l* the latter being fixed to the under side of the table *j'* as shown in Fig. 4.

The measures *l* are arranged in three sets corresponding to the three trays *i' i² i³* and their forms are such that the measures of each set correspond to spaces between the measures of the other sets in such manner that when the three sets have successively delivered their contents onto the backing its whole sur-

face will be covered. There may of course be two, four or any other number of trays and sets of measures in place of three.

m m are rollers carrying an endless band upon which the backing is supported.

The action of the machine is as follows: The trays *i' i² i³* are first (by the operation of the cam *d²*, rod *e*, rack *e'*, quadrant *f* and wheels *g*) caused to travel forward under the measures (and rest upon the bars *H* above the guard plate, *H'*, (Fig. 6), having perforations exactly corresponding to and in register with the outside of the measures *l*) which then descend on to the material in the tray. When the edges of the measures reach the bottom of the tray, or when the tray has raised portions, after they have passed the top edges of the raised portions and before they touch the bottom of the tray they are arrested by stops fixed to the frame of the machine, but the plungers continue to descend which they are free to do by compressing the spring *j²*. In this way the material in the measures is compressed into cakes which remain in the measures when the latter rise which is the next step. The trays *i' i² i³* then retire again and the measures descend this time through the guard plate being arrested by the bars *H*, at the right distance above the backing the guard plate *H'* preventing any waste material from falling onto the adjacent color the plungers continue to descend by the compression of the spring *j²* and eject the material onto the backing. The plungers and measures then again rise to their original position leaving the cakes of material attached to the backing. The latter is then advanced, (as hereinafter described,) by the width of one set of measures so that a fresh portion of the backing immediately behind the portion that has already received the material from the trays *i'* comes into position to receive the material from the tray *i'* and a like portion which has already received the material from tray *i'* comes into position to receive the material from tray *i²* and a like portion which has already received the material from trays *i' i²* comes into position to receive the material from tray *i³* while the portion which has already received the material from trays *i' i² i³* is complete as to its pattern and is passed toward pressing apparatus not shown in the drawings and the manufacture is complete.

Fig. 7 shows the method of giving a step by step motion of rotation to the roller *m*. *n* is a ratchet wheel fixed to the axis of the roller and *o* is a pawl actuated by the lever *p* pivoted at *p'* and carrying a bowl *p²* at its end. The lever *p* is caused to oscillate by the cam *q* fixed on the shaft *b*.

With some materials it is found that the edges of the cakes produced when plain trays are employed, are somewhat ragged. It is to obviate this defect that the device shown at Fig. 4 is adopted.

What I claim is—

1. In apparatus for manufacturing coverings for floors, and other surfaces, the combination of two or more sets of measures, mechanism for introducing linoleum or like material of two or more colors into said measures, means for compressing the material into the measures, mechanism for then presenting a backing to the mouths of the measures of each set in succession, and devices for each time again compressing the material on to and making it adhere to the backing.

2. In apparatus for manufacturing coverings for floors and other surfaces, the combination of a number of measures, a plunger for each measure, one set for each color, the same number of trays containing linoleum or like material of different colors, mechanism for moving the trays beneath the measures, means for causing the measures to descend into the trays, and causing the plungers to compress the material into cakes in the measures, mechanism for causing the measures with their plungers to rise, means for causing the trays to retire, devices for causing the plungers and measures to again descend, compressing the cakes on to a backing, and means for causing the said backing to advance step by step beneath the sets of various measures in succession.

3. In apparatus for manufacturing coverings for floors and other surfaces, the combination of two or more sets of measures, so arranged that the measures of each set correspond with spaces between the measures of the other set or sets, plungers in the measures, the same number of trays as there are sets of measures, projections on the bottoms of the trays fitting the insides of the measures, means for moving the trays beneath the measures, mechanism for causing the measures to descend on to the trays, the plungers compressing the material into cakes in the measures, means for causing the measures with their plungers to rise, mechanism for causing the trays to retire, devices for causing the plungers and measures to again descend compressing the cakes on to a backing, and mechanism for causing the said backing to advance step by step beneath the various sets of measures in succession.

ARTHUR SIDNEY OETZMANN.

Witnesses:

D. PERCY CARPMAEL,
DEANSTON CARPMAEL.