

C. MOORE.
LIQUID METER.

2 SHEETS—SHEET 1.

Fig. 1.

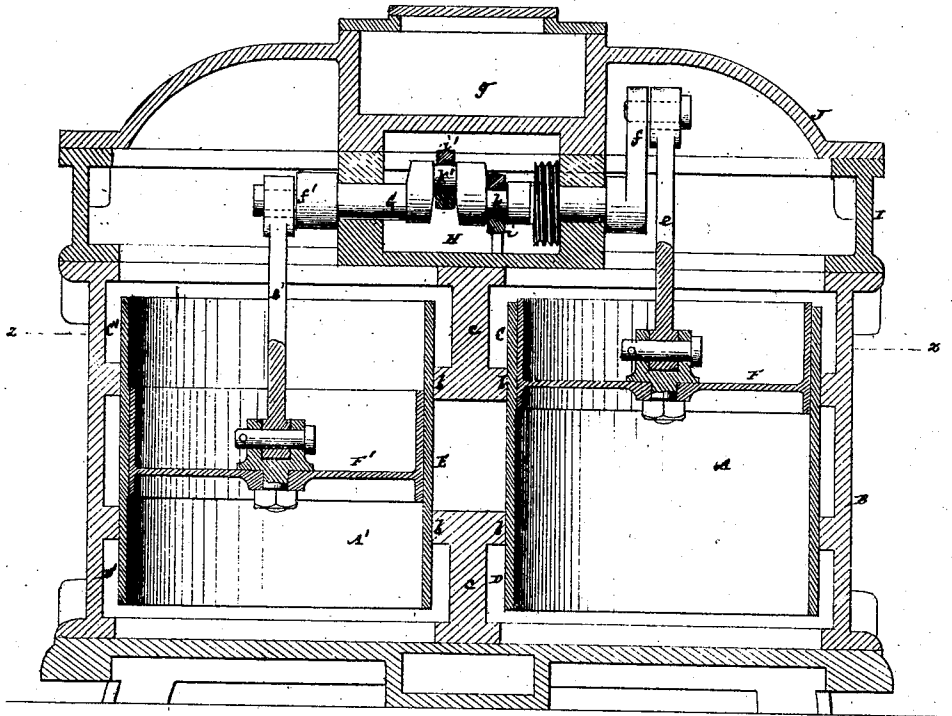
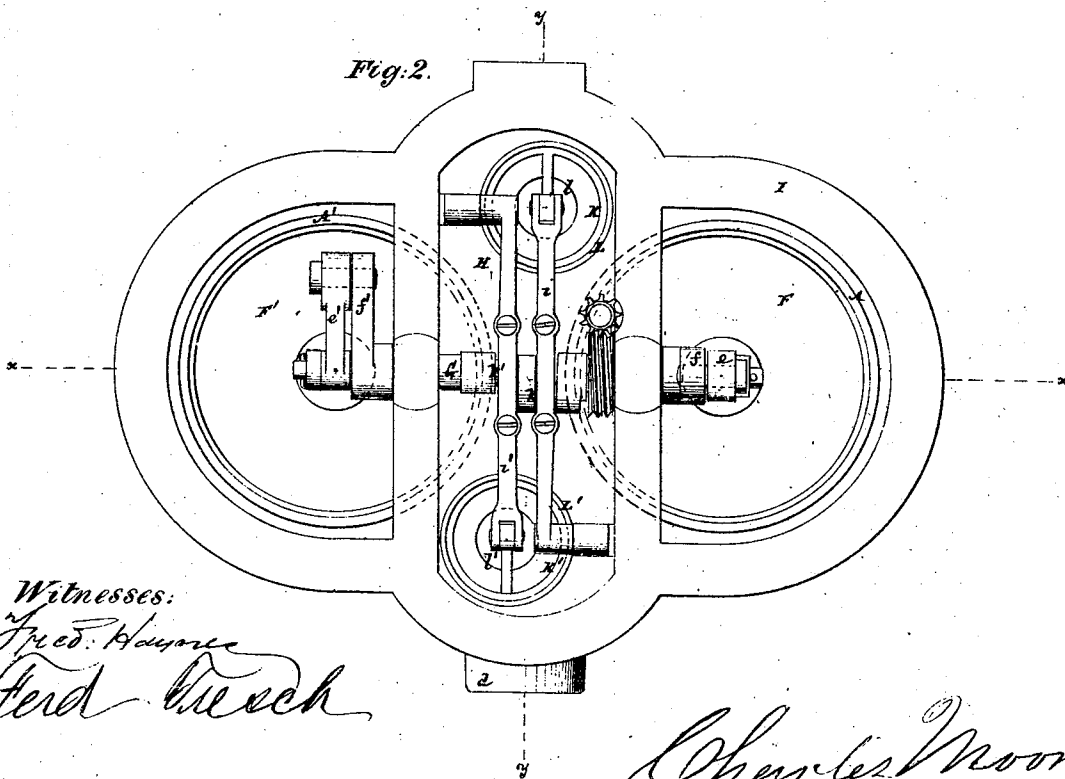

Fig. 2.



Witnesses:
Fred. Adams
Fred. Beech

Charles Moore

C. MOORE.
LIQUID METER.

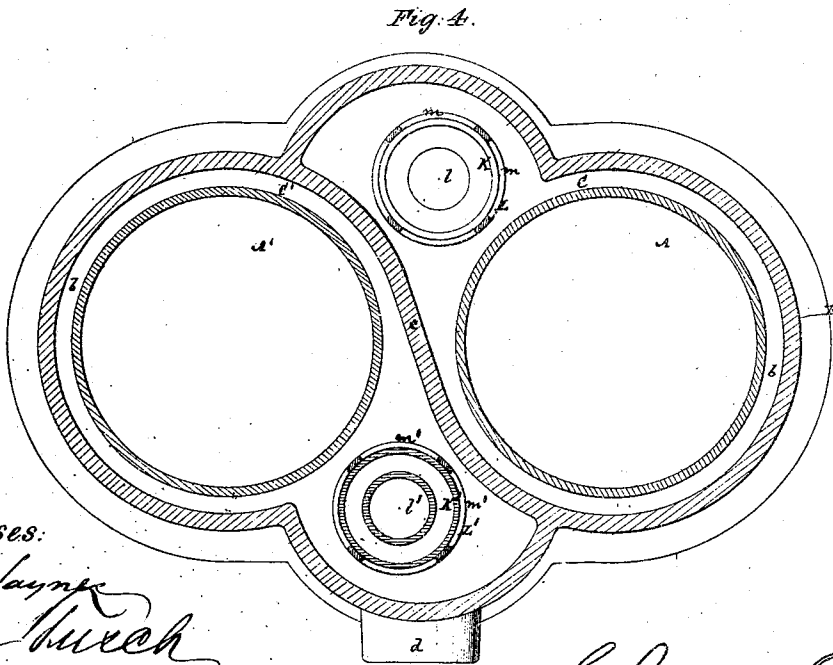
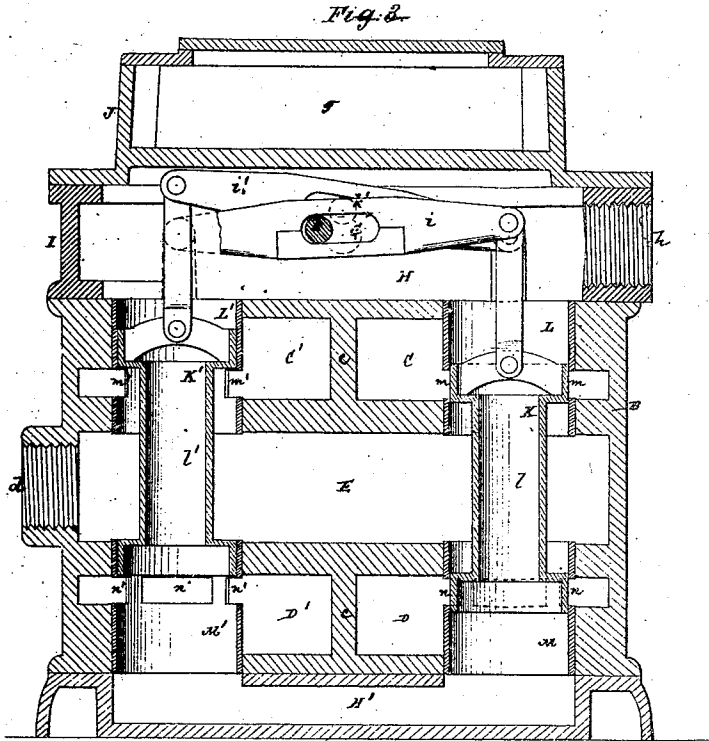

Witnesses:
Fred. Haynes
Fred. Hurch

Charles Moore

United States Patent Office.

CHARLES MOORE, OF NEW YORK, N. Y., ASSIGNOR TO JOSE F. DE NAVARRO, OF SAME PLACE.

Letters Patent No. 110,062, dated December 13, 1870.

IMPROVEMENT IN LIQUID METERS.

The Schedule referred to in these Letters Patent and making part of the same.

To all whom it may concern:

Be it known that I, CHARLES MOORE, of the city, county, and State of New York, have invented a new and useful Improvement in Liquid Meters, of which the following is a full, clear, and exact description, reference being had to the accompanying drawing forming part of this specification, and in which—

Figure 1 represents a sectional elevation of a meter constructed in accordance with my invention, said section being taken as indicated by the line $x x$ in

Figure 2, which is a plan of the meter with the cover removed;

Figure 3 is an irregular vertical section, at right angles to fig. 1, taken as indicated by the line $y y$; and

Figure 4 is a horizontal section through the line $z z$ in fig. 1, with the pistons removed from their cylinders.

Similar letters of reference indicate corresponding parts.

My invention has reference to water and other liquid meters, in which two or more reciprocating pistons are used, both of which are connected with one and the same crank-shaft, and which are made to operate valves for the purpose of controlling the pistons.

The invention consists in a certain construction of the valves and arrangement of the passages controlled by them, whereby a balancing character or action is secured for the valves, and an efficient operation of the meter generally obtained under both light and heavy streams; also, a cheap and simple construction of meter produced.

Referring to the accompanying drawing—

A and A' represent two vertical cylinders or measuring-chambers, open at their ends and arranged within a water-box or case, B, by fitting them through horizontal ribs $b b$, which, in conjunction with vertical partitions $c c$, serve to establish upper and lower separate water-spaces or chambers O D C' D', and an intermediate space, E, all surrounding or being on the outside of the cylinders, and the upper and lower of said spaces communicating respectively with the top and bottom ends of the cylinders, but the intermediate space E not being in direct communication therewith, and having connected with it the exhaust-pipe or outlet d .

The ribs $b b$ are disposed intermediately of the length of the cylinders, or at a suitable distance from their ends to form said spaces or chambers.

F F' are the reciprocating pistons of the cylinders A A'.

These pistons are connected, by pitmen $e e'$, with cranks $f f'$ of a single upper horizontal shaft, G, ar-

ranged to extend across an upper inlet water-space or chamber, H, formed in an upper box portion, I, that, in conjunction with a top or cover, J, provides spaces on either side of the chamber H for the cranks $f f'$ to revolve in.

The top J has also arranged within it a space, g , for the registering mechanism, which may be operated by a screw and worm-wheel from the main shaft, or otherwise.

The water enters the meter through the chamber H by an inlet, h , and is passed from thence, alternately, to the opposite sides of the pistons, as required, by means of valves K K', operated by beams $i i'$ arranged within the chamber H, and receiving their motion from crank or eccentric pins $k k'$ connected with the shaft G.

These valves K K', which, by the devices just described, have a vertical sliding action communicated to them, are of an irregular cylindrical shape, being formed with piston-heads at their opposite ends and a reduced body-portion in between, thereby giving to them a reel-shape.

Said valves are made tubular, having a longitudinal passage, l or l' , through them, and play—that is, their piston-heads or ends—within upper and lower cylinders or boxes, L M and L' M', open at their ends to the exhaust space or chamber E, and the upper ones L L' open also to the inlet-chamber H, while the lower ones M M' are open below with a communicating passage, H'. In this way the inlet-water is made to freely circulate through the valves, and the latter have a balance character or action secured to them.

Communication is established by these valves alternately at their opposite ends, between the chambers O D C' D' and exhaust-chamber E, to keep up a reciprocating action of the pistons by means of ports, $m n$ and $m' n'$, made in or through the cylinders L M and L' M', and communicating with the chambers O D and C' D', over which ports the piston-heads of the valves play to control the movements of the pistons.

What is here claimed, and desired to be secured by Letters Patent, is—

The combination of the tubular slide-valves K K', formed with a piston-head at either end of them, the cylinders or boxes L M and L' M' with their ports $m n$ $m' n'$, the chambers or passages H H' O D C' D', the exhaust-chamber or passage E, and the cylinders A A' with their pistons F F', for operation in concert with or through a crank-shaft, G, substantially as specified.

CHARLES MOORE.

Witnesses:

FRED. HAYNES,
FERD. TUSCH.