

(19)



Europäisches Patentamt

European Patent Office

Office européen des brevets



(11)

EP 0 594 548 B1

(12)

EUROPEAN PATENT SPECIFICATION

(45) Date of publication and mention
of the grant of the patent:

13.08.1997 Bulletin 1997/33

(51) Int Cl.⁶: **E03F 5/22, F04D 15/02**

(21) Application number: **93850173.1**

(22) Date of filing: **08.09.1993**

(54) **A device for providing automatic circulation in a waste water pumping station**

Vorrichtung zur automatischen Zirkulation in Abwasserpumpstation

Dispositif pour circulation automatique dans une station de pompage des eaux usées

(84) Designated Contracting States:
DE FR GB IT NL

(30) Priority: **24.09.1992 SE 9202759**

(43) Date of publication of application:
27.04.1994 Bulletin 1994/17

(73) Proprietor: **ITT Flygt Aktiebolag**
S-171 25 Solna (SE)

(72) Inventor: **Landquist, Folke**
S-198 00 Balsta (SE)

(74) Representative: **Larsson, Sten**
ITT FLYGT AB
Box 1309
171 25 Solna (SE)

(56) References cited:
• **EP-A- 0 058 648**
• **EP-A- 0 384 903**
• **EP-A- 0 472 509**

EP 0 594 548 B1

Note: Within nine months from the publication of the mention of the grant of the European patent, any person may give notice to the European Patent Office of opposition to the European patent granted. Notice of opposition shall be filed in a written reasoned statement. It shall not be deemed to have been filed until the opposition fee has been paid. (Art. 99(1) European Patent Convention).

Description

The invention concerns a device for providing circulation in pumping stations which are parts of a municipal sewage system.

As is described in the European Patent Application EP-A-0,058,648 sludge banks occur in pumping stations and other tanks in a sewage system as the circulation is not good enough. Sludge banks mean a lot of problems such as a bad smell, risk for explosions, corrosion problems etc.

According to the Patent Application mentioned, the problems have been solved by arranging a valve in the pump outlet, which is opened temporarily thus obtaining a circulation and flushing in the pumping station. The sludge banks are dissolved and the fluid is homogenized.

The adjustment of the valve has up to now been controlled by electric means by help of a linear motor which acts upon a slide in the valve. A disadvantage with this solution, in addition to a relatively high cost, is that it easily becomes clogged as the pumped medium normally contains large amounts of solid bodies such as stones, rags and other objects. If a stone is stuck in the valve slide, the electric motor may break down.

Another disadvantage is that the motor of the valve is electrically driven which means specific installation problems where explosive gas may occur.

The purpose of this invention is to obtain a device which in a simple and reliable way controls the valve and which is less sensitive to clogging. This is obtained by help of the method and the device stated in the claims.

The invention is described more closely below with reference to the enclosed drawings.

Fig 1 shows a pumping station with a pump unit and attached valve. Figs 2 to 4 show the principle design of the valve in different operating positions.

In the drawings 1 stands for a pumping station with a submersible pump unit 2 connected to a pressure pipe 3. 4 stands for the pump housing having an inlet 5, while 6 stands for a mixing valve mounted on the pump housing 4. 7 stands for a cylindric part of the valve 6 and 8 its outlet. 9 stands for a pressure connection from the pump housing 4, 10 a membrane housing with a membrane 11 which parts two chambers 12 and 13. 14 stands for a partition wall having an opening 15, 16 an additional chamber, 17 a flexible wall, 18 a valve flap having a leading edge and 20 finally a valve seat.

The device operates in the following manner: Normally the valve 6 is closed and the pumped medium is transported from the pump housing 4 and into the pressure pipe 3. The flow direction is shown by the Arrow A.

During certain times, for instance at pump start, the valve is open, which means that a certain amount of the pumped medium flows through the valve, arrow B, and obtains a strong agitation in the pump station wrenching possible sludge banks. After a certain time, the valve is

closed and the pumping takes place in the normal way.

The valve 6 comprises a cylindric part 7 and an outlet 8. A pressure pipe 9 from the pump housing 4 is connected to the cylindric part 7 via a membrane housing 10 having a first chamber 12. The pressure therein acts upon a membrane 11 which in its turn influences on the pressure in another chamber 13 containing a dampening medium such as oil. The chamber 13 is further limited by a wall 14 provided with a narrow opening 15 creating a connection with a second oil chamber 16. The latter has a flexible wall 17 arranged to be able to act upon a valve flap 18 for a temporary closing of the valve 6.

Fig 2 shows the valve in an open position which means that circulation is taking place in the pumping station. The valve flap 18 then takes a position entirely beside the flow. This is the situation at pump start.

The pressure in the pump housing 4 will then, via the connection 9, propagate into the chamber 12 and act upon the membrane 11. The oil in the chamber 13 will then be pressed through the opening 15 in the rigid wall 14 into the other chamber 16 causing the flexible wall 17 to move upwards in the drawing. The wall 17 is formed with a bead which acts upon the valve flap 18 against its spring force, outwards into the flow through the valve 6. As soon as the edge 19 of the flap 18 has moved so far out into the flow, that a part of the latter begins to enter behind, above the flap, the latter will swing out entirely and obtain a sealing contact with the seat 20, thus interrupting the flow through the valve 6. Fig 3 shows the device in a position where the flow starts entering behind the flap, while Fig 4 shows the valve in an entirely shut position.

The movement of the flap 18 in closing direction is entirely obtained by help of the pressure from the pump outlet and against the force from a not shown spring which acts to keep the flap in the position shown in Fig 2.

When the flap has reached the position shown in Fig 4, the valve 6 is closed and will remain so as long as the pump operates. When the pump stops, the flap is brought back to the position shown in Fig 2 and the valve is open at next pump start.

The pressure in the pump outlet thus acts upon the flap 18 via the chamber 12, the membrane 11 the chamber 13 the opening 15 and the chamber 16. The time before which the flap is being closed may be decided by dimensioning the opening 15. The smaller opening, the longer time before enough oil has flown into the chamber 16 to obtain a sufficient force onto the flap 18. The suitable opening time may vary depending on the type of pump station and is preferably possible to adjust from outside.

55 Claims

1. A device for providing automatic circulation in sewage water pumping stations containing one or sev-

eral pump units, preferably centrifugal pumps of the submersible type, one or several being provided with mixing valves, which automatically, during a certain limited time period, or periods, connect the pressure side of a pump with a pumping station (1) thus obtaining a circulation of the pumped medium, and in which the alternative return connection to the pumping station (1) is via a valve (6) comprising a housing (10) connected to the pressure side of the pump by a pipe (9), characterized in that it comprises a housing (10) which is connected to a cylinder shaped part (7) of the valve (6) and contains a membrane (11), one side of which being acted upon by the pressure in the pump housing (4), while its other side constitutes a wall of a chamber (13) containing a dampening medium such as oil, and a spring loaded valve flap (18) which is mounted within the cylinder shaped part (7) of the valve and arranged to be able to close said valve and interrupt the circulation, the valve flap (18) being arranged to be directly or indirectly moved against the spring force in a closing direction by the pressure in the chamber (13) controlled by the membrane (11).

2. A device according to claim 1, characterized in that the chamber (13), via an opening (15), is connected to another chamber (16) which has a flexible wall (17) arranged to be able to act upon the valve flap (18) in a closing direction.
3. A device according to claim 2, characterized in that the opening (15) is adjustable for controlling of the time when the pressure in the chamber (16) is strong enough to make the valve flap (18) swing out into the flow through the valve (6) and interrupt the circulation.

Patentansprüche

1. Vorrichtung zum Schaffen einer automatischen Zirkulation in Abwasser-Pumpstationen, die eine oder mehrere Pumpeneinheiten enthalten, vorzugsweise Zentrifugalpumpen des tauchbaren Typs, wobei eine oder mehrere derselben mit Mischventilen versehen sind, die während einer bestimmten, begrenzten Zeitdauer oder Zeitdauern die Druckseite einer Pumpe automatisch mit einer Pumpstation (1) verbinden, um dadurch eine Zirkulation des Pumpmediums zu erhalten, und wobei die alternative Rückverbindung zu der Pumpstation (1) über ein Ventil (6) erfolgt, das ein Gehäuse (10) aufweist, das über ein Rohr (9) mit der Druckseite der Pumpe verbunden ist, dadurch gekennzeichnet, daß sie ein Gehäuse (10) aufweist, das mit einem zylindrisch ausgebildeten Teil (7) des Ventils (6) verbunden ist und eine Membran (11) enthält, deren

eine Seite von dem Druck in dem Pumpengehäuse (4) beaufschlagt wird, während ihre andere Seite eine Wand einer Kammer (13) bildet, die ein Dämpfungsmedium, wie Öl, enthält, sowie eine unter Federvorspannung stehende Ventilklappe (18) aufweist, die in dem zylindrisch ausgebildeten Teil (7) des Ventils angebracht ist und zum Schließen des Ventils und Unterbrechen der Zirkulation ausgelegt ist, wobei die Ventilklappe (18) derart ausgebildet ist, daß sie sich entgegen der Federkraft durch den durch die Membran (11) gesteuerten Druck in der Kammer (13) direkt oder indirekt in einer Schließrichtung bewegen läßt.

2. Vorrichtung nach Anspruch 1, dadurch gekennzeichnet, daß die Kammer (13) über eine Öffnung (15) mit einer weiteren Kammer (16) verbunden ist, die eine flexible Wand (17) aufweist, die dazu ausgelegt ist, in Schließrichtung auf die Ventilklappe (18) zu wirken.
3. Vorrichtung nach Anspruch 2, dadurch gekennzeichnet, daß die Öffnung (15) verstellbar ist, um die Zeit zu steuern, zu der der Druck in der Kammer (16) ausreichend stark ist, um die Ventilklappe (18) durch das Ventil (6) nach außen in die Strömung hineinzuschwenken und dadurch die Zirkulation zu unterbrechen.

Revendications

1. Dispositif pour fournir une circulation automatique dans des stations de pompage d'eau d'égout contenant une ou plusieurs unités de pompe, de préférence des pompes centrifuges du type submersible, dont une ou plusieurs sont munies de vannes de mélange, qui automatiquement, pendant une certaine période ou des périodes de temps limitées, relie le côté de refoulement d'une pompe avec une station de pompage (1) obtenant ainsi une circulation du milieu pompé, et dans lequel la connexion de retour alternée à la station de pompage (1) s'effectue via une vanne (6) comprenant un boîtier (10) relié au côté de refoulement de la pompe par un tuyau (9), caractérisé en ce qu'il comprend un boîtier (10) qui est relié à une pièce (7) de la vanne (6) en forme de cylindre et contient une membrane (11), dont un côté est actionné par la pression dans le boîtier (4) de pompe, pendant que son autre côté constitue une paroi d'une chambre (13) contenant un milieu d'amortissement tel que de l'huile, et un volet (18) chargé par un ressort qui est monté dans la pièce (7) de la vanne en forme de cylindre et qui est agencé pour être capable de fermer ladite vanne et interrompre la circulation, le volet de vanne (18) étant agencé pour être directement ou indirectement déplacé contre la force de ressort, dans

un sens de fermeture par la pression dans la chambre (13) commandée par la membrane (11).

2. Dispositif selon la revendication 1, caractérisé en ce que la chambre (13), est reliée, via une ouverture (15), à une autre chambre (16) qui a une paroi flexible (17) agencée pour être capable d'actionner le volet (18) de vanne dans un sens de fermeture.
3. Dispositif selon la revendication 2, caractérisé en ce que l'ouverture (15) est réglable pour commander la durée pendant laquelle la pression dans la chambre (16) est suffisamment importante pour faire basculer le volet (18) de vanne dans le flux à travers la vanne (6) et interrompre la circulation.

5

10

15

20

25

30

35

40

45

50

55

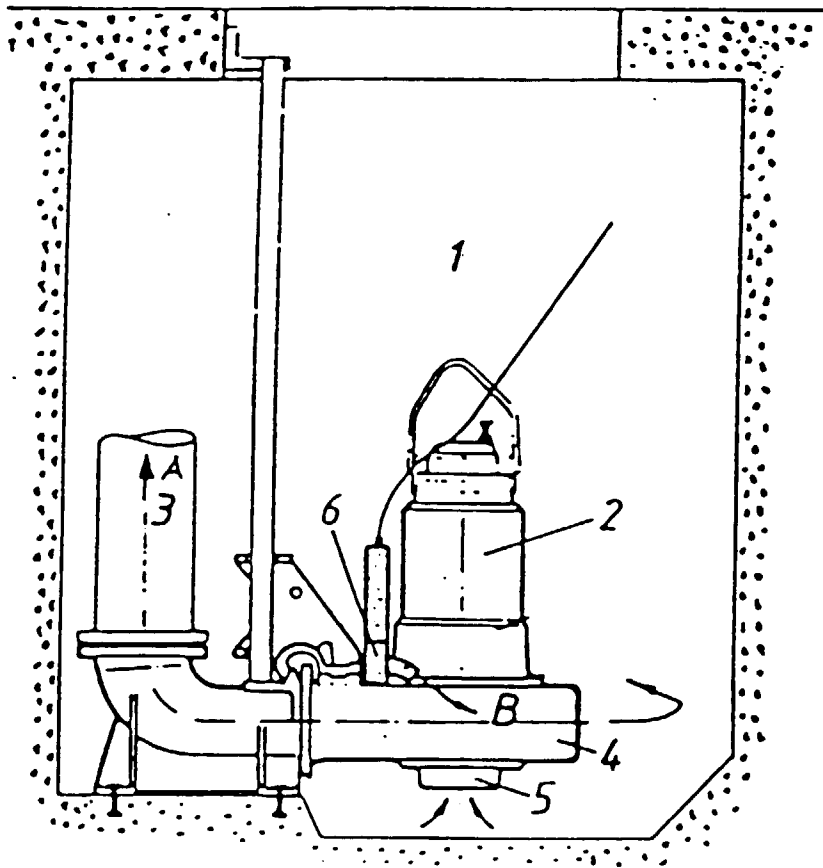

Fig-1

