



US 20080200131A1

(19) **United States**

(12) **Patent Application Publication**
Franca-Neto

(10) **Pub. No.: US 2008/0200131 A1**

(43) **Pub. Date: Aug. 21, 2008**

(54) **CHIP PACKAGE WITH TRANSCEIVER FRONT-END**

Related U.S. Application Data

(63) Continuation of application No. 10/196,091, filed on Jul. 16, 2002, now Pat. No. 7,383,058.

(76) Inventor: **Luiz M. Franca-Neto**, Hillsboro, OR (US)

Publication Classification

Correspondence Address:
SCHWABE, WILLIAMSON & WYATT, P.C.
PACWEST CENTER, SUITE 1900, 1211 S.W.
FIFTH AVE.
PORTLAND, OR 97204

(51) **Int. Cl.**
H04B 1/38 (2006.01)
(52) **U.S. Cl.** **455/73**

(57) **ABSTRACT**

Various embodiments describe a chip package having a transceiver front-end. The transceiver front-end may be coupled to a communication processor on a die disposed on the chip package. Other embodiments may be described and claimed.

(21) Appl. No.: **12/107,602**

(22) Filed: **Apr. 22, 2008**

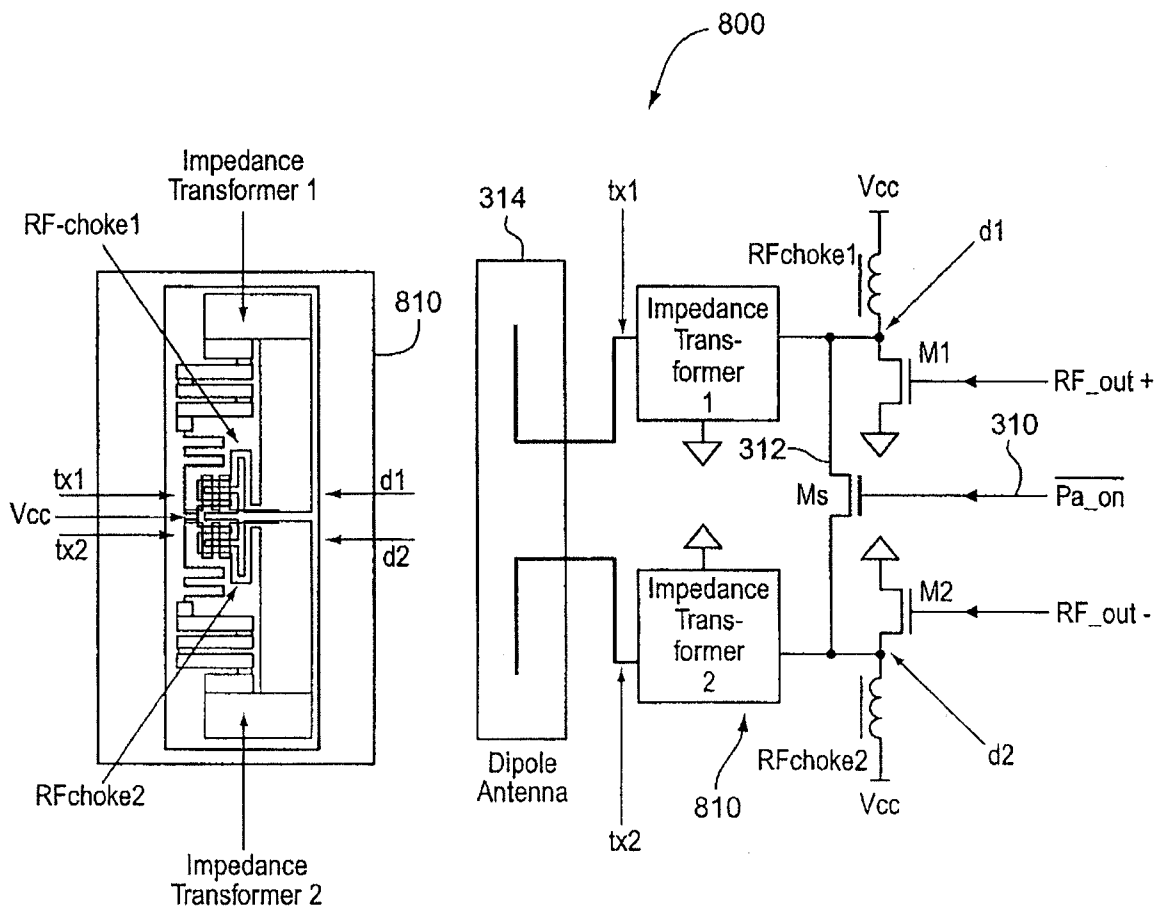

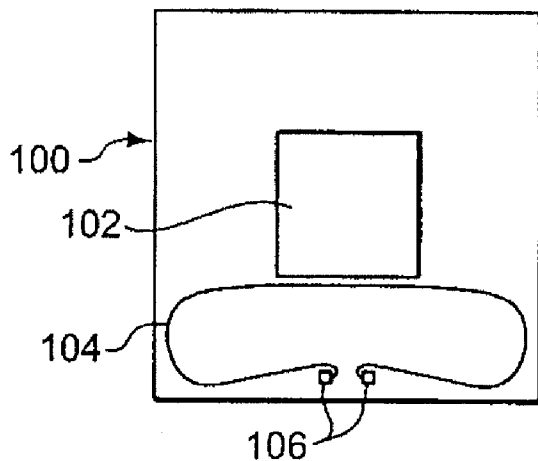

FIG. 1A

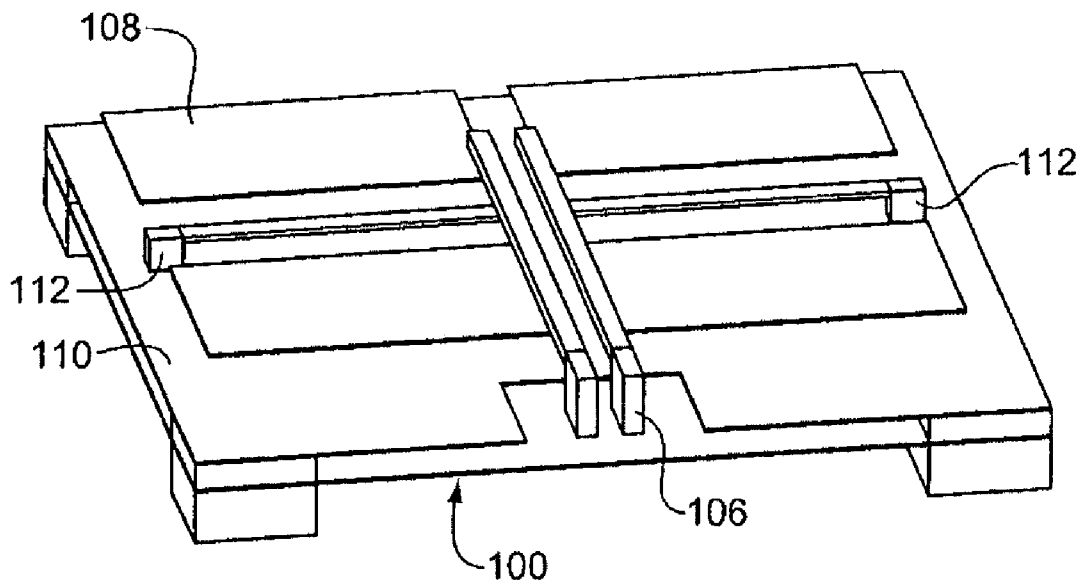

FIG. 1B

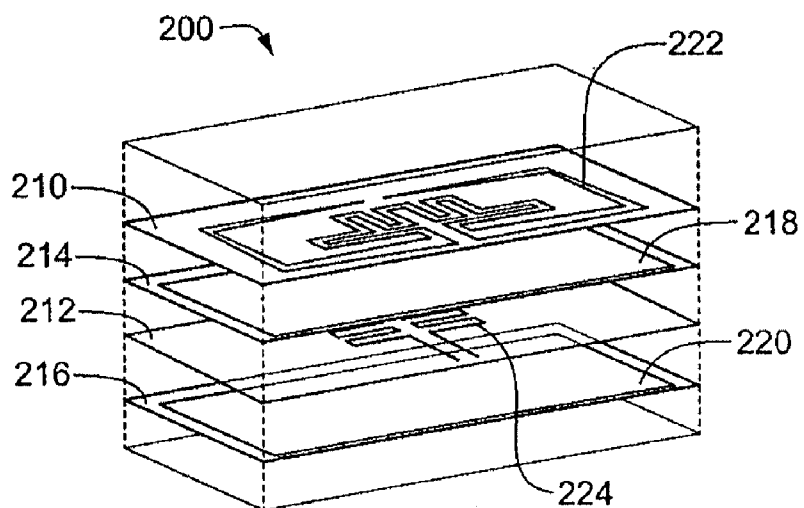

FIG. 2A

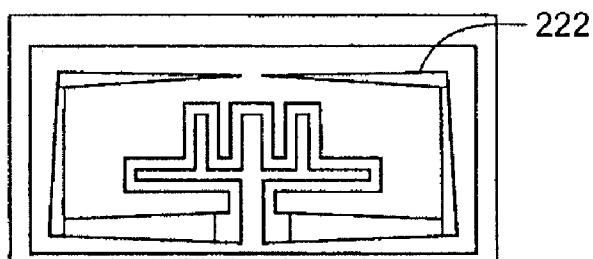

FIG. 2B

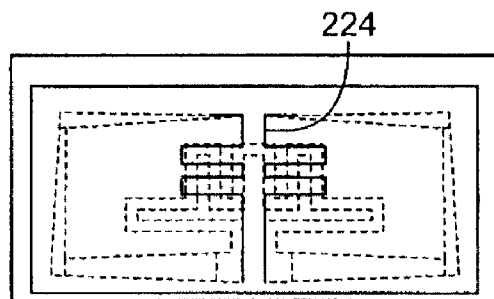

FIG. 2C

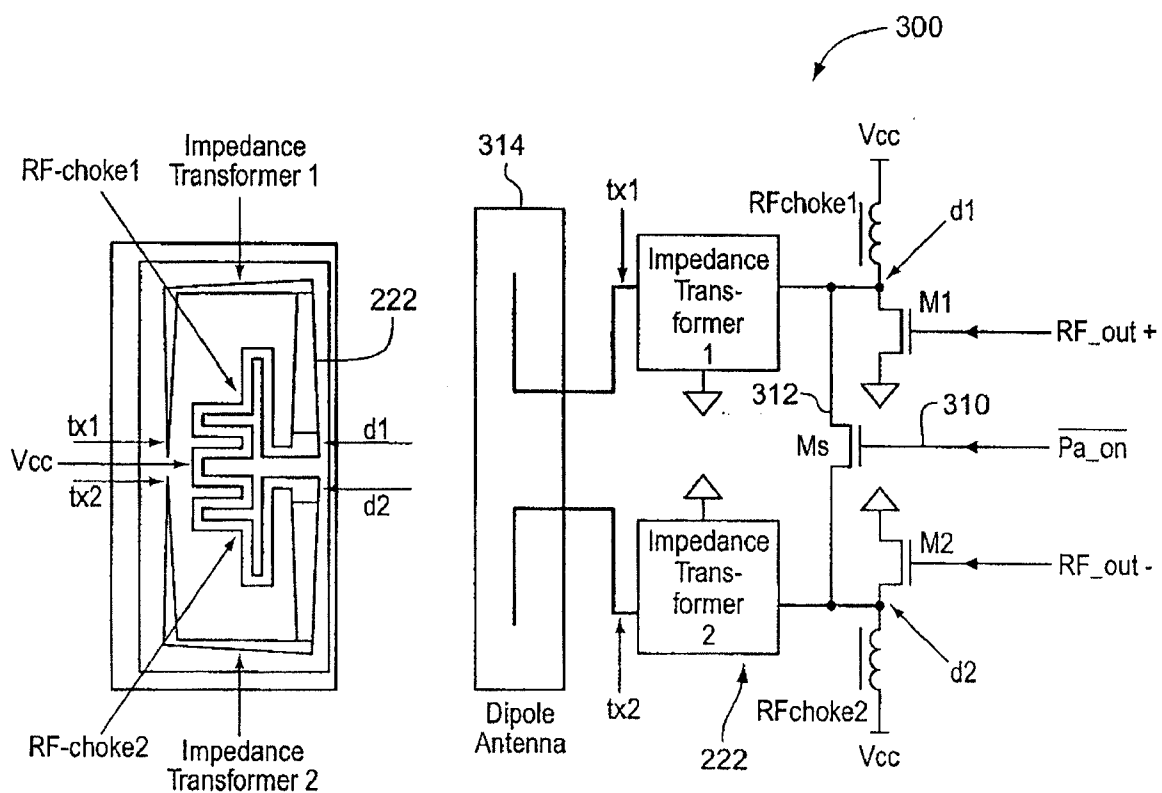

FIG. 3

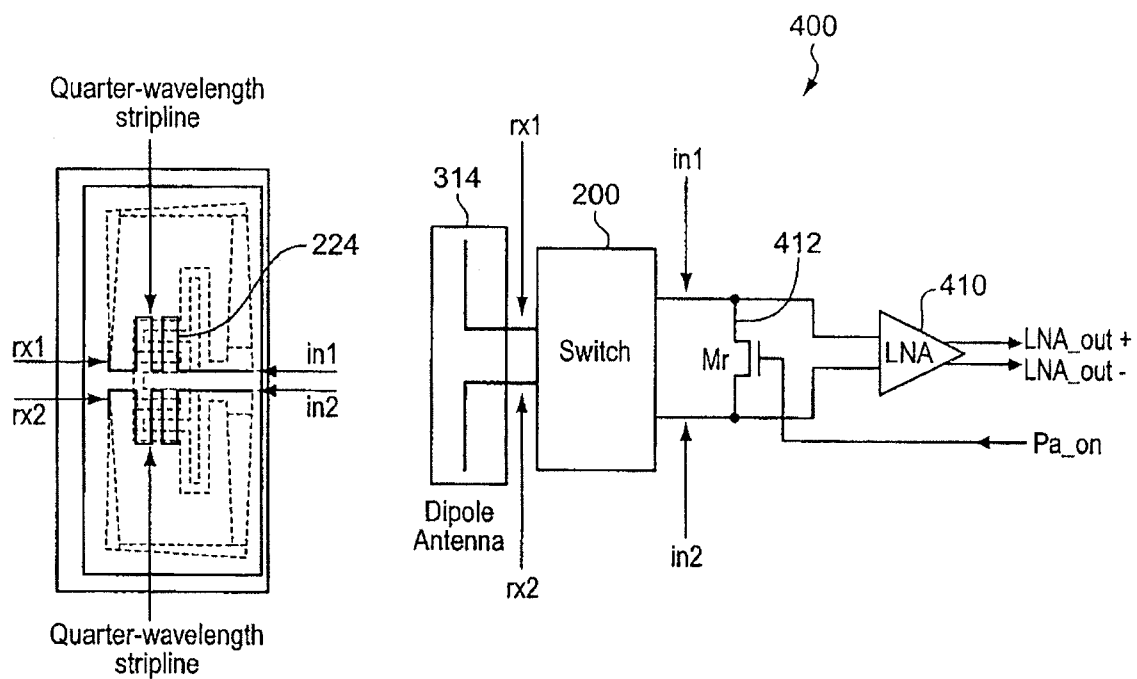

FIG. 4

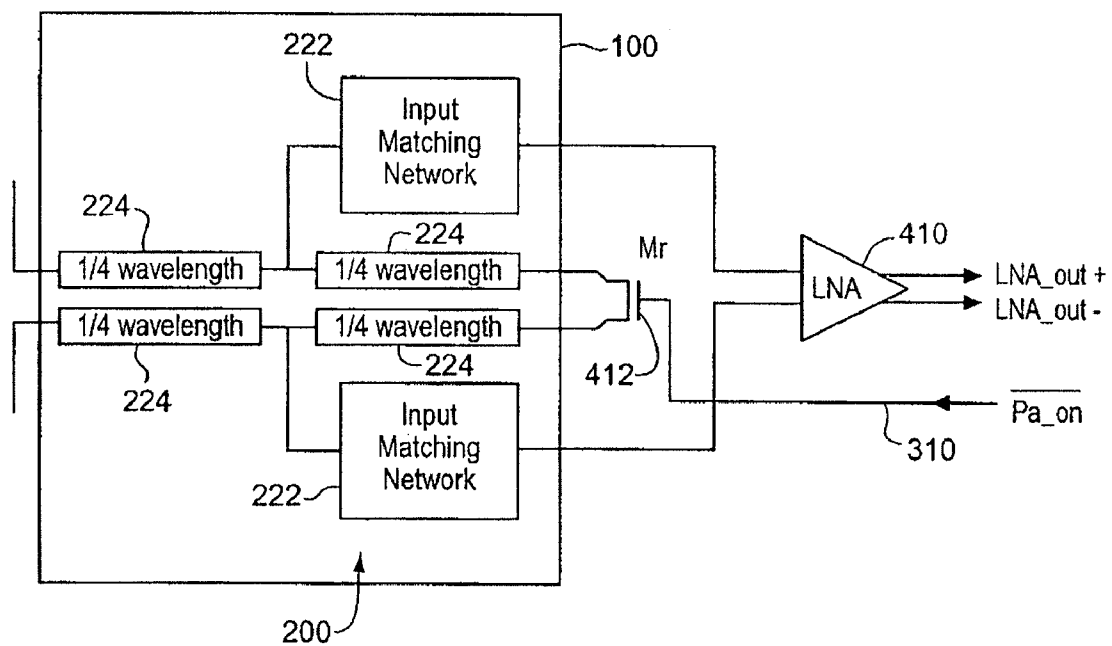

FIG. 5

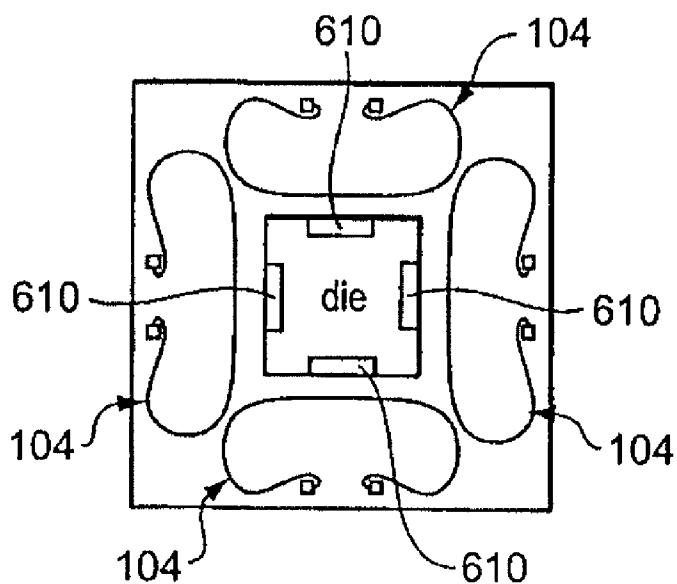

FIG. 6

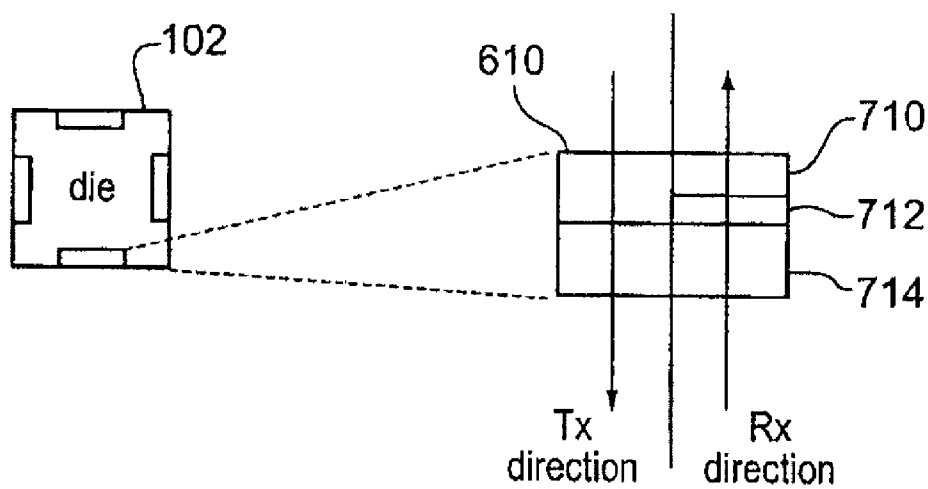

FIG. 7

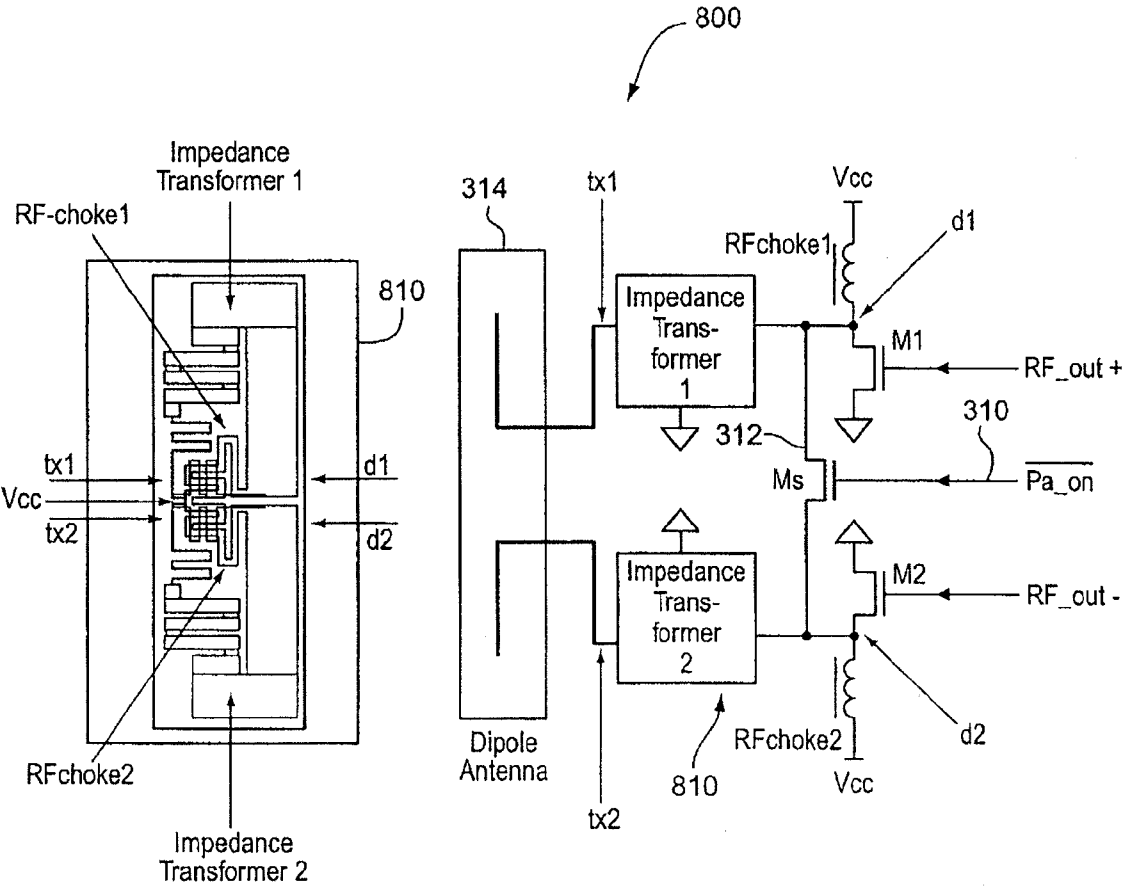

FIG. 8

CHIP PACKAGE WITH TRANSCEIVER FRONT-END

CROSS REFERENCE TO RELATED APPLICATIONS

[0001] The present application is a continuation of, and claims priority to, U.S. patent application Ser. No. 10/196,091, filed Jul. 16, 2002, entitled "RF/Microwave System with a System on a Chip Package or the like." The specification of said application is hereby incorporated by reference in its entirety for all purposes, except for those sections, if any, that are inconsistent with this specification.

FIELD

[0002] Embodiments relate to the field of wireless communications and, in particular, to a chip package with a transceiver front-end.

BACKGROUND

[0003] Radio-Frequency (RF) and microwave front-end integration with higher-performance digital processors is becoming possible by utilizing ever more complex CMOS technology system integration. Available on-die isolation plus judicious layout and circuit techniques enable the integration of delicate RF/Microwave front ends in a hostile digital environment. Nevertheless, isolation problems generally call for fixed, higher performance passive components in order to provide a non-compromising RF/Microwave subsystem performance for wireless communications. These higher quality components are generally not available on-die and are provided external to the system package. The antenna-switch, the input matching network and the impedance transformer and RF-choke for the transmitter power amplifier are the passive elements of a transceiver system.

DESCRIPTION OF THE DRAWING FIGURES

[0004] The numerous aspects of the present invention may be better understood by those skilled in the art by reference to the accompanying figures in which:

[0005] FIG. 1A is a diagrammatic illustration of an RF/microwave system disposed on a single package in accordance with the present invention.

[0006] FIG. 1B is an isometric diagram of an antenna disposed on a flip-chip package such as that shown in FIG. 1A.

[0007] FIG. 2 is an exploded view of a multi-layer differential antenna switch in accordance with the present invention.

[0008] FIG. 3 is a physical trace illustration and a corresponding circuit diagram illustration of a transmitter power amplifier front end of a transceiver in accordance with the present invention.

[0009] FIG. 4 is a physical trace illustration and a corresponding circuit diagram a receiver end of a transceiver circuit in accordance with the present invention.

[0010] FIG. 5 is a circuit diagram of an alternative embodiment of antenna switch in accordance with the present invention.

[0011] FIG. 6 is a diagrammatic illustration of a multiple RF/microwave system-on-a-package in accordance with the present invention.

[0012] FIG. 7 is a diagram of an on die software-hardware partition for a communication processor in accordance with the present invention.

[0013] FIG. 8 is a circuit diagram of an alternative embodiment of antenna switch where the power amplifier impedance transformer is implemented with a 3-step tapered transmission line.

DETAILED DESCRIPTION

[0014] Referring now to FIG. 1A, a diagrammatic illustration of an RF/microwave subsystem disposed on a single chip in accordance with a particular embodiment of the present invention will be discussed. A chip package 100 is shown in FIG. 1A as including a die 102 disposed centrally thereon. Package 100 may be a multilayer package in one embodiment of the invention. An area 104 disposed on flip-chip package 100 external to die 102 may be available for providing passive RF/microwave components thereon in accordance with the present invention. As shown in FIG. 1A, antenna contacts 106 may be provided to couple with the components disposed in area 104 to an antenna 108 as shown in FIG. 1B. Package 100 may be utilized, for example, in higher-performance digital processors, although the scope of the present invention is not limited in this respect. In one particular embodiment of the invention, package 100 is a flip-chip package, however the invention may encompass various other types of chip packages as well without departing from the scope of the invention and without providing substantial change thereto, although the scope of the invention is not limited in this respect.

[0015] Referring now to FIG. 1B, an antenna disposed on a chip package such as that shown in FIG. 1A will be discussed. Antenna 108 may be for example a 5.2 GHz antenna disposed on a heat-spreader 110 of a flip-chip package 100 as shown in FIG. 1A to provide a system-on-a-package solution for a device such as a handheld computer, cell phone, or the like. A system-on-a-package solution may include but not be limited to a single chip package that includes a general purpose processor in combination with a wireless system such as a transceiver and other radio-frequency (RF) and/or microwave components. Heat-spreader 110 may be supported on package 100 by one or more mechanical supports 112. The area occupied by heat-spreader 110 however is not limited by the area of package 100 and is not limited to any particular size. For example, a larger form factor structure to accommodate a 2.4 GHz Industrial, Scientific, and Military (ISM) band and omnidirectional radiation may be provided in one particular embodiment. Alternatively, the antenna structure may be placed at a distance, having its structure still connected to the top of the package thus reducing the risk that RF/microwave signals travel through vias, pins, or traces on a motherboard on which the system-on-a-package may be disposed, although the scope of the invention is not limited in this respect.

[0016] Referring now to FIG. 2, including FIGS. 2A, 2B, and 2C, an exploded view of a multi-layer differential antenna switch will be discussed. In one embodiment of the invention, FIG. 2A shows an exploded 3D view of a multi-layer differential antenna switch for a 2.4 GHz ISM radio as an example. FIG. 2B shows a tapered-line impedance transformer and RF choke 222 for a transmitter power amplifier. FIG. 2C shows a quarter wavelength stripline for connection to a receiver. The components shown in FIGS. 2, 2A, 2B, and 2C may be disposed on area 104 of package 100 as shown in and discussed with respect to FIG. 1A, although the scope of the invention is not limited in this respect.

[0017] As shown in FIG. 2A, antenna switch 200 in one embodiment includes two metal layers 210 and 212 with

traces, and two metal layers **214** and **216** with ground planes **218** and **220**. An impedance transformer and RF choke **222** of a power amplifier (not shown) may be disposed on the top metal layer **210** of package **100** and may include a tapered microstrip structure as shown in FIG. 2B. A quarter-wavelength stripline **224** may connect an antenna, for example antenna **314** of FIG. 3, to a low noise amplifier (LNA), for example LNA **410** of FIG. 4, and may be provided between ground planes **218** and **220**. In one particular embodiment, quarter-wavelength stripline **224** has an impedance of 50 ohms. The example antenna switch **200** illustrates one embodiment for a 2.4 GHz ISM band radio. Radios that operate at higher frequencies may imply smaller form factors and radios that operate at lower frequencies may imply larger form factors, both of which may be accommodated by the present invention. Switch **200** may be better understood using electrical circuit diagrams for the transmission line structures including transformer and RF choke **222** and quarter-wavelength stripline **224** on package **100** as shown in and described with respect to FIGS. 3, 4, and 5, although the scope of the invention is not limited in this respect.

[0018] Referring now to FIG. 3, a transmitter power amplifier front end of a transceiver in accordance with the present invention will be discussed. FIG. 3 depicts a transmitter power amplifier (PA) front-end, transmitter circuitry **300**, with the metal layer components being shown on the left and a representative circuit and accompanying circuitry being shown on the right. When a transceiver utilized with the present invention is in receiving mode, voltage Pa_on **310**="0", transistor Ms **312** which uses the inverted Pa_on signal shorts nodes d1 and d2. Since tapered microstrip line **224** of FIG. 2 has one-quarter wavelength length, a higher impedance relative to 50 ohms in this embodiment may be provided at nodes tx1 and tx2, thereby reducing the effect on the receiver circuitry by the presence of the transmitter circuitry as shown in FIG. 4. Analogously, when the transceiver is in transmitting mode (e.g., voltage Pa_on **310**="1"), a switching transistor, transistor Mr in the receiver circuitry **400** shown in FIG. 4 in the receiving-end may reduce the effect of receiver circuitry **400** on transmitter circuitry **300**, although the scope of the invention is not limited in this respect.

[0019] In one embodiment of the invention, tapered microstrip line **224** may transform the impedance, in this example 50 ohms, from antenna **314** into a resistance value approximately equal to 1.5 ohms, a quarter of wavelength distance away from the antenna, at nodes d1 and d2. Tapering the line may allow for both higher bandwidth operation of the impedance transformer and to ensure the higher impedance posed at nodes tx1 and tx2 when the transceiver is in receiving mode is a higher impedance with respect to 50 ohms rather than with respect to the lower 1.5 ohms. In one embodiment of the invention, switch **200** may operate in such a manner so as to render the transmitter circuitry **300** invisible to the receiver circuitry **400** when the transceiver is in a receiving mode. Such an impedance transformation optionally enables the power amplifier of transmitter circuitry **300** to deliver higher RF power to antenna **314** under lower voltage power supply lines. In one embodiment of the invention, the RF-chokes in the schematic offer a higher impedance at RF/microwave frequencies and may be realized in a particular embodiment by one-quarter wavelength highly twisted and compacted 50 ohms transmission lines placed in the area surrounded by the tapered transmission lines, which have

their extreme ac-grounded at the Vcc node by the virtual ground produced by differential operation of the transceiver. The Vcc node is placed in the symmetry axis along the differential power amplifier lines so that an ac-short, or virtual ground, is reinforced at this node without requiring a larger valued capacitor, although the scope of the invention is not limited in this respect.

[0020] Referring now to FIG. 4, a receiver end of a transceiver circuit in accordance with an embodiment of the present invention will be discussed. Stripline **224** is coupled with receiver circuitry **400** and consists of a trace sandwiched between two ground planes **218** and **220**, and in one embodiment a 50 ohms transmission line may be provided using finer traces. Such a configuration allows for denser serpentine which may allow for quarter wavelength transmission lines to be disposed in a relatively smaller area. A relatively smaller area may be utilized with the typically lower power RF signals dealt with in receiver circuitry **400**, and for compact realization of an input matching network on package **100**. During reception, quarter wavelength stripline **224** conveys a signal from antenna **314** to the low noise amplifier (LNA) **410** with little or no electrical attenuation. During transmission operation of the transceiver, quarter wavelength stripline **224** may be ac-shortened by transistor Mr **412** at nodes in1 and in2, thus providing a higher impedance at nodes rx1 and rx2, thereby reducing the effect of receiver circuitry **400** on transmitting circuitry **300**, although the scope of the invention is not limited in this respect.

[0021] Referring now to FIG. 5, an alternative embodiment of antenna switch **200** will be discussed. Since a higher quality passive input matching network may be utilized in the design of higher sensitivity receivers, FIG. 5 depicts how one such embodiment of input matching network **222** may be implemented on package **100**. Two additional quarter wavelength striplines **224** may be added to preserve the functionality of antenna switch **200**. Since transistor Mr **412** is a full wavelength away from the antenna nodes in the embodiment shown in FIG. 5, operation of transistor Mr **412** is activated by voltage Pa_on **310**="0" rather than Pa_on **310**="1", and the transmission part of switch **200** remains operating as discussed with respect to FIGS. 3 and 4, although the scope of the invention is not limited in this respect.

[0022] In an alternative embodiment of the invention, a multi-band radio solution may be provided by a straightforward extension of the concept of the invention as discussed herein. For example, radio transceivers at various ISM bands may have their passive components disposed at the other sides of the surface of the square flip-chip package **100** of FIG. 1A surrounding the die, and the antenna structure on the heat spreader may be featured as multiple independent radiators operating independently at the ISM bands, although the scope of the invention is not limited in this respect.

[0023] In one embodiment, whole shielding may be used to reduce the amount of unintended signals that radiate from the handheld, for example being slotted by design to make the system on package **100** a multi-band "slot" radiator. Moreover, in further alternative embodiments, a single band radio may have several connections to such an antenna structure so that beam steering and receiving antenna diversity also may be implemented in the system-on-a-package on package **100**. Beam steering may be utilized to provide lower power operation by not wasting signal in unintended directions but rather by aiming the beam to the intended receiver, and may co-existence at same or multiple frequencies. Moreover, if a

higher transmitted output power is desired, the power amplifier transistor on die and other passive elements on the package may be duplicated so that their combined power is added to the antenna terminals. Such an embodiment may be accommodated by using other layers of the multi-layer flip-chip package for the traces of the duplicated power amplifier, although the scope of the invention is not limited in this respect.

[0024] Referring now to FIG. 6, a diagram of a multiple system-on-a-package in accordance with an embodiment of the present invention will be discussed. In one embodiment of the invention, FIG. 6 shows an extension of a system-on-a-package concept of package 100 towards a multi-band radio transceiver implementation, where multiple antenna switches and passive components may be implemented on the multi-layer flipped-chip package 100 at corresponding multiple areas 104 on package 100. In one embodiment, transceivers in area 104 may operate without being affected by the presence of the other transceivers of the corresponding other areas. In such an embodiment, the transceivers' front-ends disposed in areas 104 may have a corresponding on-die asynchronous communication processor 610. Thus, areas 104 may contain antenna contacts and RF/microwave components for an independent radio band or frequency, each having a corresponding communication processor 610 on die 10 and may further include memory components, for example random access memory (RAM) 710, although the scope of the invention is not limited in this respect.

[0025] Referring now to FIG. 7, an embodiment of an on die software-hardware partition in a communication processor in accordance with an embodiment of the present invention will be discussed. Physical layer operations such as the RF/microwave front-end, receiver diversity, modulation, demodulation and detection, may be handled by physical layer circuitry 714. Parallel hardware may be utilized to allow the border between continuous and discrete time signal processing to be implemented for bit-rates reaching 100 Mb/s in one embodiment. Media access control (MAC) layer operations may be handled by a general purpose digital processor residing on the same die 102, although the scope of the invention is not limited in this respect.

[0026] In one embodiment of the invention, a transceiver implemented on package 100 in accordance with the present invention may operate at a lower power level. Such a lower power level may be provided by the addition of a sublayer 712 for received packet identification in the receiving direction one or more of the transceivers as indicated in FIG. 7. Sublayer 712 may operate to discard one or more or all the packets not intended to its assigned client communications processor 610. Such an arrangement allows for powering down the larger general purpose digital processor in die 102 and only waking up the digital processor when a packet intended to be directed to it arrives, although the scope of the invention is not limited in this respect.

[0027] In yet further embodiment of the invention, allocation of programmability where needed or desired may be provided. An individual communication processor 610 may be configured by software to implement a specific modulation/demodulation scheme or schemes, which may be performed by writing specific codes at assigned addresses on the RAM companion to the corresponding communication processor 610. MAC operations, being network protocol oriented, may provide programmability flexibility under the general purpose microprocessor on die 102. RAM 710 may

be provided at one or more of the communication processors 610, either outside or on die, for example to serve as a buffer for streaming in or out packets, and to allow for multi-tasking on the general purpose processor, although the scope of the invention is not limited in this respect.

[0028] Thus, in one embodiment of the invention, one or more transceivers may be provided on package 100 each being designed to operate at a particular frequency or frequencies to that a desired frequency band of operation for package 100 may be selected by selecting on or more appropriate transceivers. Furthermore, each of the transceivers may be individually programmed to operate at one or more frequencies or modulation schemes, providing a further layer of programmability. This allows a single package 100 to provide multiple radio solutions that may be flexibly altered or reprogrammed as desired, although the scope of the invention is not limited in this respect.

[0029] Referring now to FIG. 8, a circuit diagram of an alternative embodiment of antenna switch where the power amplifier impedance transformer is implemented with a 3-step tapered transmission line will be discussed. The operation of transmitter circuitry 800 in FIG. 8 is similar to the operation of transmitter circuitry 300 of FIG. 3, with the metal layer components being shown on the left and an equivalent circuit and accompanying circuitry being shown on the right. Tapered-line impedance transformer and RF choke 810 corresponds to tapered-line impedance transformer and RF choke 222 of FIG. 3, a difference being that tapered-line impedance transformer and RF choke 810 utilizes a 3-step tapered line for the power amplifier impedance transformation. In one embodiment, tapered-line impedance transformer and RF choke 810 comprises two RF chokes, RF-choke 1 and RF-choke 2, made of quarter wavelength microstrips, with Vcc supply placed at symmetry axis (ac ground), thus producing higher impedances and nodes d1 and d2. Impedance transformers, Impedance Transformer 1 and Impedance Transformer 2, may be tapered three-quarter wavelength microstrips to convert an impedance of antenna 314 from 50 ohms into 1.5 to 2.0 ohms. Transistor Ms 312 may short the differential lines to produce a higher impedance at the terminals of antenna 314 during reception, although the scope of the invention is not limited in this respect.

[0030] Although the invention has been described with a certain degree of particularity, it should be recognized that elements thereof may be altered by persons skilled in the art without departing from the spirit and scope of the invention. It is believed that the RF/microwave system for system on a chip package or the like of the present invention and many of its attendant features will be understood by the forgoing description, and it will be apparent that various changes may be made in the form, construction and arrangement of the components thereof without departing from the scope and spirit of the invention or without sacrificing all of its material advantages, the form herein before described being merely an explanatory embodiment thereof, and further without providing substantial change thereto. It is the intention of the claims to encompass and include such changes.

What is claimed is:

1. An apparatus, comprising:
 - a chip package having a plurality of transceiver front-ends, each of the plurality of transceiver front ends having one or more passive components implemented by one or more trace structures disposed on one or more layers of the chip package; and

- a die disposed on said chip package and having a plurality of communication processors, each of the plurality of communication processors coupled to a respective transceiver front end of the plurality of transceiver front-ends.
- 2. The apparatus of claim 1, wherein at least one of the plurality of communication processors includes physical layer circuitry to implement a modulation or a demodulation scheme.
- 3. The apparatus of claim 1, wherein at least one of the plurality of communication processors includes a memory layer to interface with a general purpose processor disposed on said die.
- 4. The apparatus of claim 1, wherein at least one of the plurality of communication processors includes a sublayer to identify whether a packet is intended for the corresponding communications processor.
- 5. The apparatus of claim 1, wherein a first communication processor of the plurality of communication processors includes a sublayer to identify whether a packet is intended for the first communication processor, said first communication processor to operate in a lower power mode by being powered down until said sublayer identifies a packet intended for the first communication processor.
- 6. The apparatus of claim 1, wherein said chip package is a flip-chip package.
- 7. The apparatus of claim 1, further comprising an antenna to couple with each of the plurality of transceiver front-ends.
- 8. The apparatus of claim 1, wherein the one or more passive components of at least one of the plurality of transceiver front-ends includes a switch.
- 9. The apparatus of claim 8, wherein the switch includes a matching network.
- 10. The apparatus of claim 8, wherein the switch includes an impedance transformer and radio frequency (RF) choke.
- 11. The apparatus of claim 8, wherein the switch includes a quarter-wavelength stripline
- 12. The apparatus of claim 1, further comprising: a heat spreader coupled to said chip package; and

- an antenna coupled with at least one of the plurality of transceiver front-ends and disposed on the heat spreader.
- 13. The apparatus of claim 1, wherein the chip package is a multi-layered chip package and at least a first one of the plurality of transceiver front-ends includes one or more passive components implemented by a plurality of trace structures disposed on a plurality of layers of the chip package.
- 14. The apparatus of claim 10, further comprising: a circuit board having the multi-layered chip package disposed thereon.
- 15. An apparatus comprising: a package having a plurality of layers; a die disposed on said package and having a communication processor; and one or more passive components of a transceiver front-end implemented by one or more trace structures disposed on at least two layers of the plurality of layers of the package and coupled to the communication processor.
- 16. The apparatus of claim 15, wherein the one or more passive components comprise: an impedance transformer and a radio-frequency choke disposed on a first layer of the at least two layers of the package.
- 17. The apparatus of claim 16, wherein the impedance transformer includes a tapered microstrip structure.
- 18. The apparatus of claim 16, wherein the one or more passive components further comprise: a quarter-wavelength stripline disposed on a second layer of the at least two layers of the package.
- 19. The apparatus of claim 15, further comprising: an antenna structure coupled to the one or more passive components; and a heat spreader having the antenna structure disposed thereon.
- 20. The apparatus of claim 15, wherein the one or more passive components include a switch having a matching network.

* * * * *