



US007593761B1

(12) **United States Patent**
Toth et al.

(10) **Patent No.:** **US 7,593,761 B1**
(45) **Date of Patent:** **Sep. 22, 2009**

- (54) **METHOD AND APPARATUS OF DETERMINING AND DISPLAYING AN ARTIFACT INDEX**

6,023,494 A	2/2000	Senzig et al.
6,094,468 A	7/2000	Wilting et al.
6,115,487 A	9/2000	Toth et al.
6,115,489 A	9/2000	Gupta et al.
6,215,841 B1	4/2001	Hsieh
6,222,642 B1	4/2001	Farrell et al.
6,325,539 B1	12/2001	Bromberg et al.
6,359,958 B2	3/2002	Toth
6,366,638 B1	4/2002	Hsieh
6,438,195 B1	8/2002	Hsieh
6,480,560 B2	11/2002	Hsieh
6,501,849 B1	12/2002	Gupta et al.
6,529,574 B1	3/2003	Hsieh
6,587,537 B1	7/2003	Hsieh
6,600,802 B1	7/2003	Hsieh
6,680,995 B2	1/2004	Toth et al.
6,983,180 B2*	1/2006	Toth et al. 600/407
2002/0071600 A1	6/2002	Yamada
2003/0083565 A1	5/2003	Toth et al.
- (75) Inventors: **Thomas L. Toth**, Brookfield, WI (US);
Piero Simoni, Brookfield, WI (US)
- (73) Assignee: **General Electric Company**,
Schenectady, NY (US)
- (*) Notice: Subject to any disclaimer, the term of this patent is extended or adjusted under 35 U.S.C. 154(b) by 912 days.
- (21) Appl. No.: **11/160,027**
- (22) Filed: **Jun. 6, 2005**

Related U.S. Application Data

- (60) Continuation of application No. 10/065,450, filed on Oct. 18, 2002, now Pat. No. 6,983,180, which is a division of application No. 09/682,914, filed on Oct. 31, 2001, now Pat. No. 6,680,995.

* cited by examiner

Primary Examiner—Brian Casler
Assistant Examiner—James Kish
(74) *Attorney, Agent, or Firm*—Ziolkowski Patent Solutions Group, SC

- (51) **Int. Cl.**
A61B 6/00 (2006.01)
- (52) **U.S. Cl.** **600/407**; 600/425; 378/4; 378/901; 382/131; 382/260
- (58) **Field of Classification Search** 600/407, 600/410, 425, 436, 437, 443; 382/128, 131, 382/132; 378/1, 4, 5, 21, 51, 54–56, 62
See application file for complete search history.

(57) **ABSTRACT**

An apparatus and process for determining and displaying an artifact index (AI) to a system operator are provided. The AI is determined by acquiring and processing imaging data of a phantom. The AI is then displayed to the operator on a console so that the operator may, if necessary, reset the scanning parameters or select a new scanning protocol that will result in a reconstructed image of a subject having reduced artifact presence. By providing a likelihood of artifact presence to the system operator, the present invention eliminates the need for the operator to recall those scanning profiles that are susceptible to high artifact presence.

(56) **References Cited**

U.S. PATENT DOCUMENTS

- 5,602,891 A 2/1997 Pearlman
- 5,809,105 A 9/1998 Roehm et al.
- 5,818,896 A 10/1998 Hsieh
- 5,841,828 A 11/1998 Gordon et al.

32 Claims, 5 Drawing Sheets

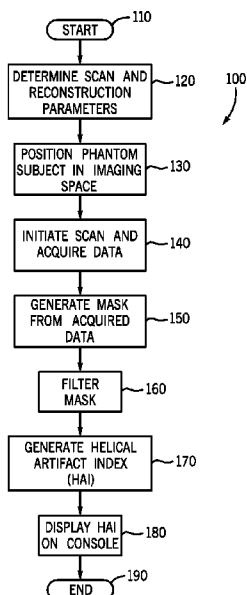

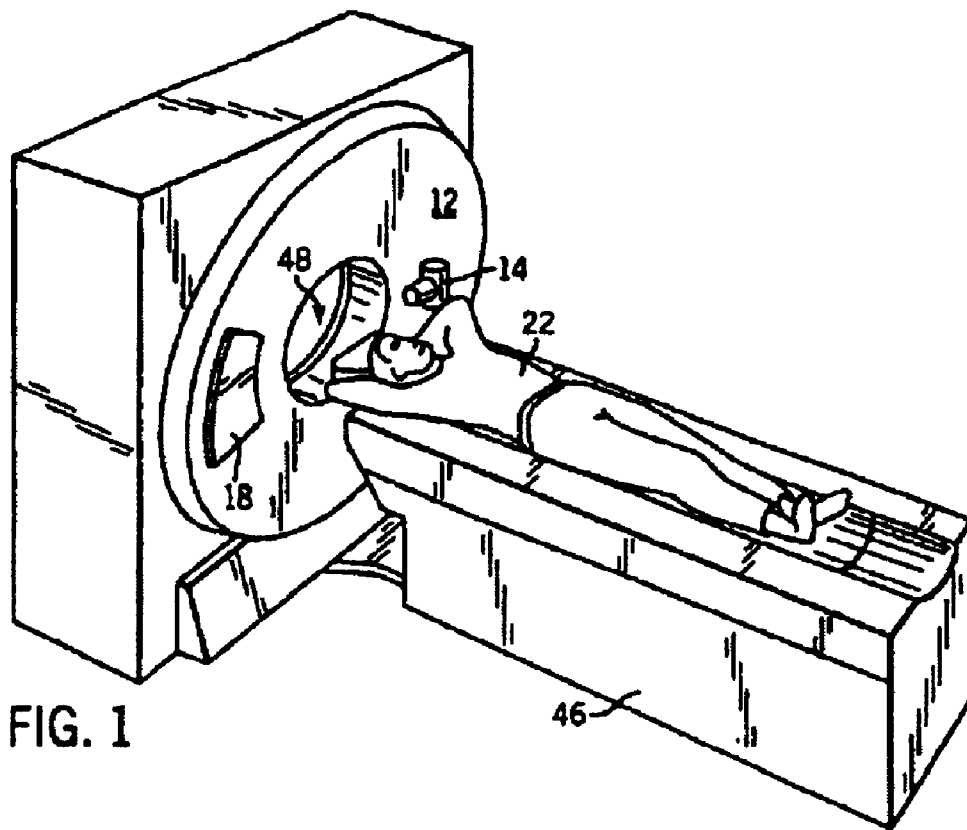
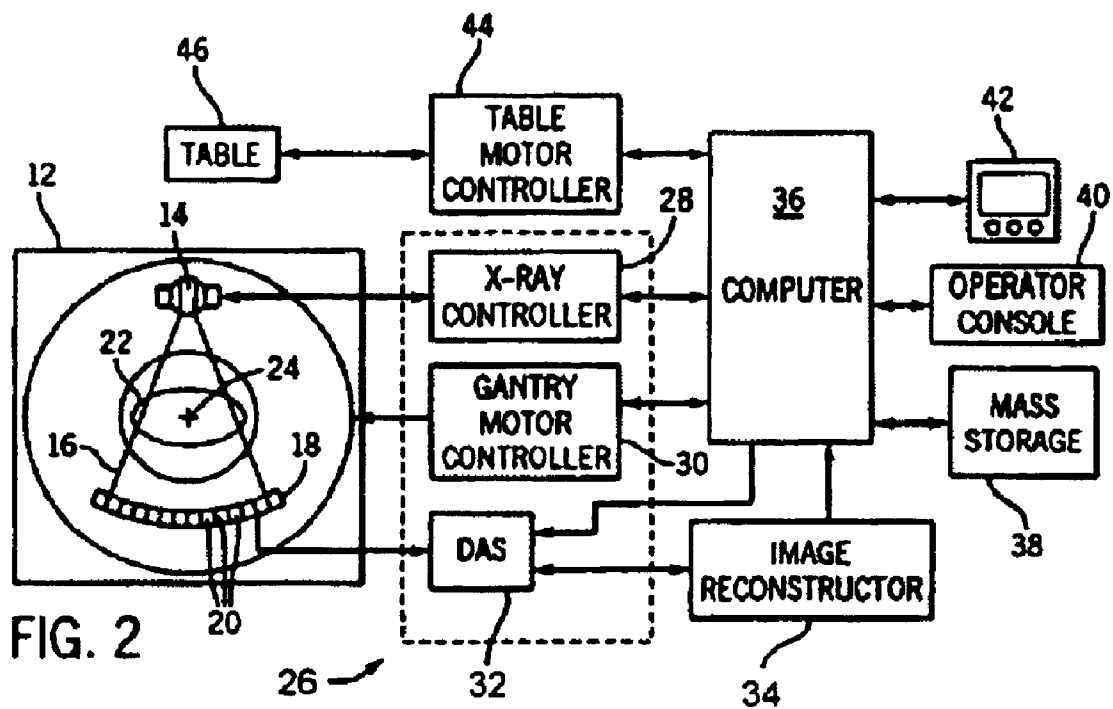

FIG. 1



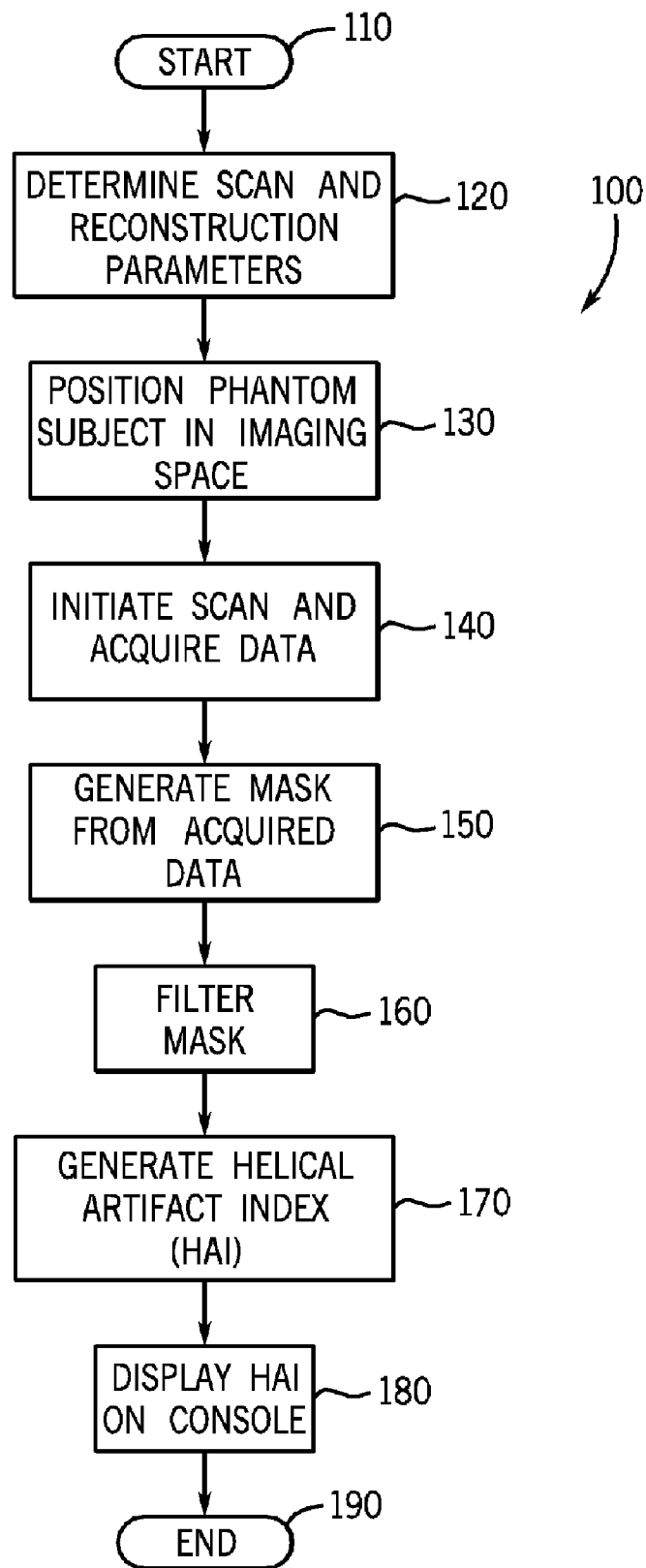

FIG. 3

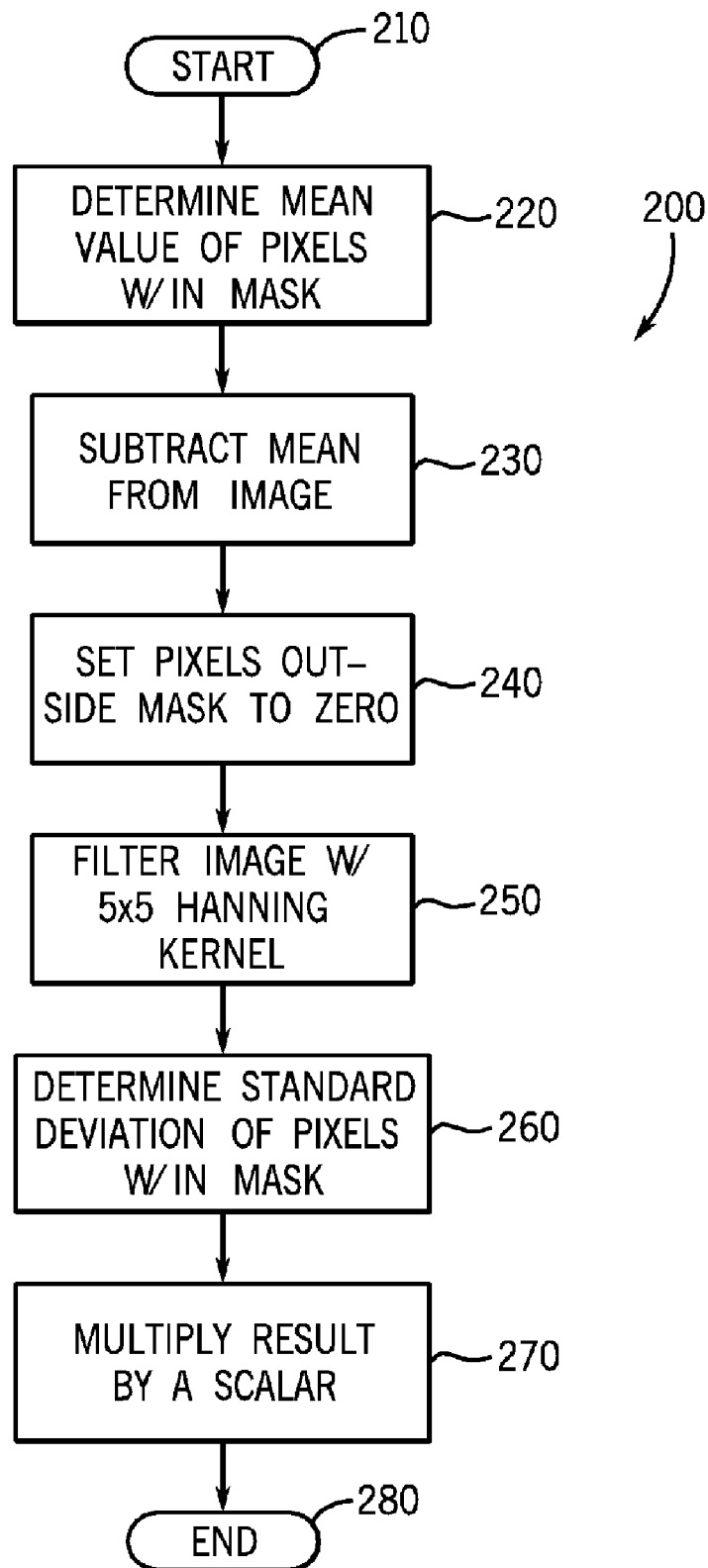

FIG. 4

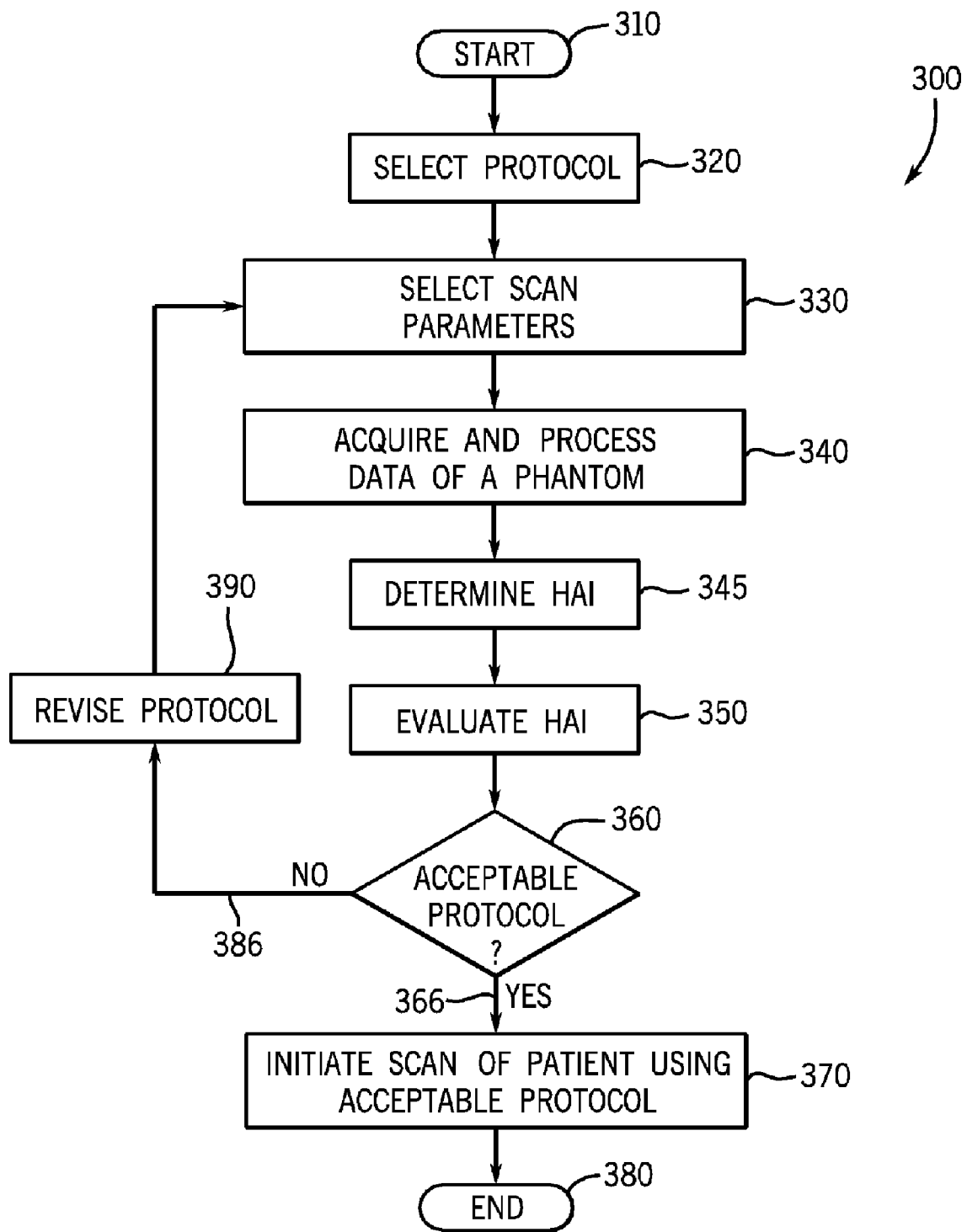

FIG. 5

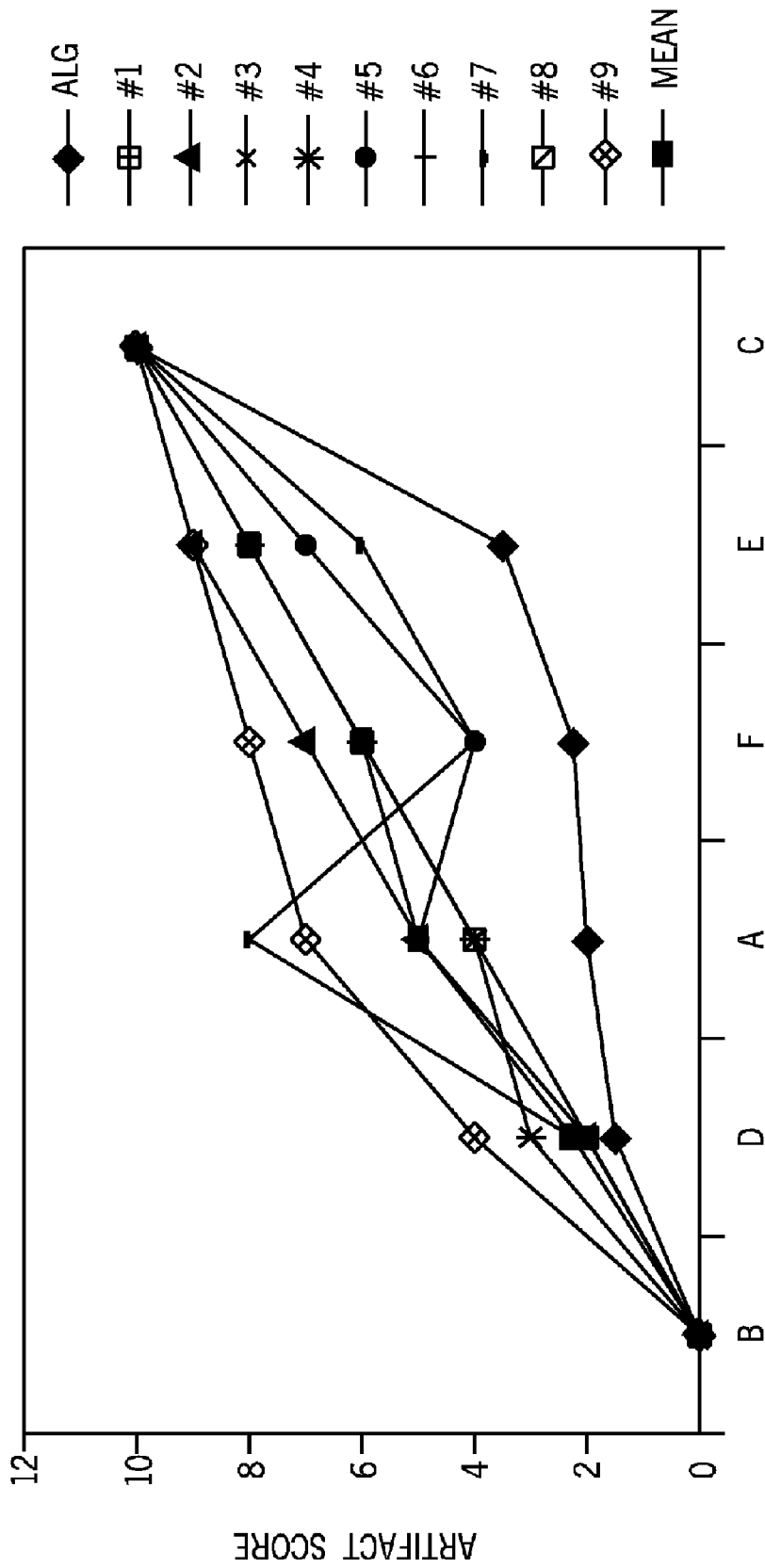

FIG. 6

1

METHOD AND APPARATUS OF DETERMINING AND DISPLAYING AN ARTIFACT INDEX

CROSS-REFERENCE TO RELATED APPLICATION

The present application is a continuation and claims priority of U.S. Ser. No. 10/065,450 filed Oct. 18, 2002 now U.S. Pat. No. 6,983,180 which is a divisional and claims priority of U.S. Ser. No. 09/682,914 filed Oct. 31, 2001 and entitled "Method and Apparatus of Determining and Displaying a Helical Artifact Index, now U.S. Pat. No. 6,680,995."

BACKGROUND OF THE INVENTION

The present invention relates generally to medical imaging and developing imaging protocols and, more particularly, to a method and apparatus to determine a likelihood of artifact presence in a reconstructed image and displaying the likelihood of artifact presence to an operator for evaluation. The present invention enables redevelopment and/or redesigning of the imaging protocol based upon the likelihood of artifact presence in a reconstructed image.

Typically, helical reconstruction algorithms produce artifacts in a reconstructed image due to data inconsistencies generated by a patient translation in a z direction during gantry rotation. While the intensity of artifacts depends in large part on the particular scanning parameters of the scanning session, generally these artifacts are most intense around high contrast interfaces such as bone/tissue (ribs) or air/tissue cavities. Additionally, artifact intensity typically increases with pitch but may also change depending upon the implemented helical reconstruction algorithm and detector width used to acquire imaging data.

With known imaging systems, it is incumbent upon the scanner operator to understand the artifact intensity with prescribing a patient examination. Typically, the operator learns from experience whether a particular scan procedure will result in an increased or decreased artifact presence. Moreover, the operator must be cognizant of scan versus artifact presence for a number of scanning possibilities without the benefit of any visual queues. While under some circumstances a large artifact presence in the final reconstructed image is not bothersome, for other scan procedures a reconstructed image absent visual artifacts is paramount.

For single slice CT systems that employ simple reconstruction weighting schemes, the scanning operators typically utilize the helical pitch of the scan as an indication of expected artifact. This can be difficult however for a new or inexperienced operator or for a CT system that has numerous operating modes. Furthermore, in multi-slice CT systems, with various pitch and detector width selections, an operator or technologist may find it very difficult to remember what to expect for each set of operating conditions.

Therefore, it would be desirable to design an apparatus and method that determines and visually displays a likelihood of artifact presence in a reconstructed image for evaluation by a scan system operator. Further, it would be desirable to design such a system that enables the system operator to provide feedback to the system such that artifact presence is reduced in a subsequent imaging session.

BRIEF DESCRIPTION OF THE INVENTION

An apparatus and process overcoming the aforementioned drawbacks is provided and includes determining and display-

2

ing a helical artifact index (HAI) to a system operator. The HAI is determined by acquiring and processing imaging data of a phantom. The HAI is then displayed to the operator on a console so that the operator may, if necessary, reset the scanning parameters or select a new scanning protocol that will result in a reconstructed image of a patient having reduced artifact presence. By providing a likelihood of artifact presence to the system operator, the present invention eliminates the need for the operator to recall those scanning profiles that are susceptible to high artifact presence.

Therefore, in accordance with one aspect of the present invention, a method of generating a helical artifact score is provided. The method includes acquiring a set of data values and setting a subset of the set of data values to an initial value. After setting the subset of data values to an initial value, the method includes filtering the set of data values. Next, a likelihood of artifact presence is determined from the filtered set of data values.

In accordance with another aspect of the present invention, a computer-readable medium having stored thereon a computer program that, when executed by one or more computers, causes the one or more computers to acquire imaging data of a phantom from an external device. The imaging data includes a plurality of pixels. The computer program further causes the one or more computers to isolate a first set and a second set of pixels and set one of the first set and the second set to an initial value. After setting one of the first set and the second set to an initial value, the computer program causes the one or more computers to filter the imaging data and determine a helical artifact index (HAI) therefrom. The computer program then causes the one or more computers to visually display the HAI on a console.

In yet another aspect of the present invention, a CT system is provided and comprises a rotatable gantry having an opening and a high frequency electromagnetic energy projection source to project high frequency energy toward an object. The CT system further includes a scintillator array having a plurality of scintillators to receive high frequency electromagnetic energy attenuated by the object. A photodiode array is provided having a plurality of photodiodes. The photodiode array is optically coupled to the scintillator array and is configured to detect light energy emitted therefrom. The CT system further includes a plurality of electrical interconnects configured to transmit photodiode outputs to a data processing system and a computer program to acquire and process data to determine a likelihood of an artifact risk presence in a reconstructed image. The computer of the CT system is further programmed to notify an operator of the determined likelihood.

Various other features, objects and advantages of the present invention will be made apparent from the following detailed description and the drawings.

BRIEF DESCRIPTION OF THE DRAWINGS

The drawings illustrate one preferred embodiment presently contemplated for carrying out the invention.

In the drawings:

FIG. 1 is a pictorial view of a CT imaging system.

FIG. 2 is a block schematic diagram of the system illustrated in FIG. 1.

FIG. 3 is a flow chart setting forth the steps of displaying a likelihood of artifact presence in a reconstructed image in accordance with the present invention.

FIG. 4 is a flow chart setting forth the steps of determining a likelihood of artifact presence.

After the imaging data is filtered at **250**, a standard deviation of the pixels within the mask is determined at **260**. The standard deviation is determined by squaring the pixels within the mask, summing the squares, and dividing the sum by the total number of pixels within the mask. At **270**, the standard deviation is then multiplied by a scalar suitable to obtain a maximum score of 10 for the worst case of artifact presence in a reconstructed image and a minimum score of 1 for the best case of artifact risk over the set of parameters available to the user. Setting a worst case score to 10 and a best case score to 1 is illustrative of only one embodiment that may be used to ascertain an artifact risk value. That is, a best case score of 10 and a worst case score of 1 or any variation thereof is contemplated herein and is within the scope of the present invention. Process **200** then ends at **280** with the visual displaying of the artifact risk value, in a preferred embodiment, as a visual bar graph on a scan Rx console at **180** of FIG. 3 as was heretofore discussed.

Referring to FIG. 5, algorithm **300** sets forth the steps of an acquisition, pre-processing, and reconstruction process in accordance with the present invention. Algorithm **300** begins at **310** with the selection of a scanning protocol at **320**. Once the appropriate protocol is selected at **320**, scan parameters are identified and selected at **330** that satisfy the requirements of the prescribed imaging session. Imaging data is then acquired and processed of a phantom at **340** whereupon an HAI index is determined at **345** in accordance with acts **110-190** of process **100**, FIG. 3. The determined HAI is then evaluated by the system operator at **350** to determine if the implemented protocol selected at **320** is acceptable **360**. That is, if the HAI indicates a high likelihood of artifact presence and such a presence is unacceptable, the operator may determine at **360** that the protocol is unacceptable. However, if the artifact presence is low or that a high artifact presence is tolerable, the operator may determine that the protocol selected and implemented at **320** is acceptable.

If the protocol is acceptable **360**, **366**, the pre-processing process is complete and a scan of a patient using the acceptable protocol is executed at **370** whereupon algorithm **300** concludes at **380** with the reconstruction of an image. However, if the system operator determines at **360** that the protocol was not acceptable **386**, the pre-processing process continues at **390** with a revising of the protocol at **390**. Revising the reconstruction protocol allows the system operator to alter the reconstruction algorithm used to process the data or select new scan parameters at **330** that will facilitate image reconstruction with minimal artifact presence. Once the protocol is revised at **390** and, if necessary, new scan parameters are selected at **330**, pre-processing continues at **340** with the acquisition and processing of data of a phantom and subsequent HAI determination and evaluation at **345** and **350**. These pre-processing steps continue until an acceptable protocol is determined at **360**. That is, regeneration of an HAI during pre-processing allows the system to provide visual feedback in the form of a bar graph to the operator so that a correct protocol may be selected and implemented.

Referring to FIG. 6, a histogram illustrating a comparison of artifact score assessment of the process of the present invention versus artifact score assessment by human observers is shown. That is, a set of helical body phantom images were evaluated using the helical artifact index generation process of the instant application. Those images were then presented to a set of skilled observers who were asked to sort and grade the images on a scale of 1 to 10 ranging from best to worst. As shown in FIG. 6, the artifact index generation process of the instant application scored the images in the same sequence as the skilled human observers thereby con-

firming that the helical artifact index generation process of the instant application correctly assigned index values to the images presented to the skilled observers.

Therefore, in accordance with one embodiment of the present invention, a method of generating a helical artifact score is provided. The method includes acquiring a set of data values and setting a subset of the set of data values to an initial value. After setting the subset of data values to an initial value, the method includes filtering the set of data values. Next, a likelihood of artifact presence is determined from the filtered set of data values.

In accordance with another embodiment of the present invention, a computer-readable medium having stored thereon a computer program that, when executed by one or more computers, causes the one or more computers to acquire imaging data of a phantom from an external device. The imaging data includes a plurality of pixels. The computer program further causes the one or more computers to isolate a first set and a second set of pixels and set one of the first set and the second set to an initial value. After setting one of the first set and the second set to an initial value, the computer program causes the one or more computers to filter the imaging data and determine a helical artifact index (HAI) therefrom. The computer program then causes the one or more computers to visually display the HAI on a console.

In yet another embodiment of the present invention, a CT system is provided and comprises a rotatable gantry having an opening and a high frequency electromagnetic energy projection source to project high frequency energy toward an object. The CT system further includes a scintillator array having a plurality of scintillators to receive high frequency electromagnetic energy attenuated by the object. A photodiode array is provided having a plurality of photodiodes. The photodiode array is optically coupled to the scintillator array and is configured to detect light energy emitted therefrom. The CT system further includes a plurality of electrical interconnects configured to transmit photodiode outputs to a data processing system and a computer program to acquire and process data to determine a likelihood of an artifact risk presence in a reconstructed image. The computer of the CT system is further programmed to notify an operator of the determined likelihood.

The present invention has been described in terms of the preferred embodiment, and it is recognized that equivalents, alternatives, and modifications, aside from those expressly stated, are possible and within the scope of the appending claims.

What is claimed is:

1. A computer readable medium having stored thereon a computer program that, when executed by a computer, causes the computer to:

reconstruct an image comprising a plurality of pixels from imaging data acquired from an object;
isolate a first set and a second set of pixels in the image;
set the first set of pixels to an initial value;
thereafter, filter the imaging data;
determine an artifact index (AI); and
visually display the AI on a console.

2. The computer readable medium of claim 1 wherein the program, in causing the computer to reconstruct the image, causes the computer to reconstruct the image comprising a plurality of pixels from imaging data acquired from the object, the imaging data comprising data acquired from the object via one of a CT scanner, an MRI scanner, an x-ray scanner, a PET imaging system, and an ultrasound imaging system.

7

3. The computer readable medium of claim 1 wherein the program, in causing the computer to reconstruct the image, causes the computer to reconstruct an image comprising a plurality of pixels from imaging data acquired from an object that has a shape to simulate an anatomical region of a patient.

4. The computer readable medium of claim 3 wherein the program, in causing the computer to reconstruct the image, causes the computer to reconstruct an image comprising a plurality of pixels from imaging data acquired from an object that has a shape to simulate a bone region.

5. The computer readable medium of claim 4 wherein the program, in causing the computer to reconstruct the image, causes the computer to reconstruct an image comprising a plurality of pixels from imaging data acquired from an object that has a shape to simulate a rib.

6. The computer readable medium of claim 3 wherein the program, in causing the computer to reconstruct the image, causes the computer to reconstruct an image comprising a plurality of pixels from imaging, data acquired from an object that has a shape to simulate tissue.

7. The computer readable medium of claim 1 wherein the computer program that causes the computer to the first set of pixels to an initial value further causes the computer to set the first set of pixels to zero.

8. The computer readable medium of claim 1 wherein the computer program further causes the computer to determine a mean of the second set of pixels.

9. The computer readable medium of claim 8 wherein the computer program further causes the computer to subtract the mean from the imaging data.

10. The computer readable medium of claim 1 wherein the computer program further causes the computer to:

square each pixel of the second set of pixels;
sum the squares;
divide the sum by a number of pixels of the second set of pixels; and
modify the quotient by a scalar.

11. The computer readable medium of claim 1 wherein the second set of pixels includes imaging values within ± 40 CT numbers of a range of an expected uniform material value.

12. The computer readable medium of claim 1 wherein the second set of pixels includes pixels having no visual artifact.

13. The computer readable medium of claim 1 wherein the computer program further causes the computer to display the AI on the console as at least one of a histogram and a bar graph.

14. A method of generating an artifact score, the method comprising:

reconstructing an image having a plurality of pixels from imaging data acquired from a subject;
partitioning the plurality of pixels into a first set and a second set;
initializing the first set to a base value;

8

determining an artifact index (AI) from at least one of the first set and the second set; and
visually conveying the AI.

15. The method of claim 14 wherein the step of partitioning includes the step of generating a mask from the plurality of pixels.

16. The method of claim 15 wherein the step of generating a mask further comprises the step of identifying a set of pixels within a range of an expected uniform material value.

17. The method of claim 16 wherein the range is ± 40 CT numbers.

18. The method of claim 16 wherein the step of identifying the set of pixels comprises isolating a region of the plurality of pixels absent visual artifacts.

19. The method of claim 16 further comprising the step of determining a numeric mean of the set of pixels within the range.

20. The method of claim 19 further comprising the step of subtracting the mean from each pixel of the plurality of pixels.

21. The method of claim 16 further comprising steps of:
squaring each pixel of the plurality of pixels;
summing the squared pixels; and
dividing the summation by a mask pixel count.

22. The method of claim 21 further comprising the step of modifying the quotient by a scalar.

23. The method of claim 22 further comprising the step of determining the scalar by statistically correlating trained observers responses to a reconstructed image of the imaging data.

24. The method of claim 22 wherein the step of determining an artifact index includes the step of determining a likelihood of artifact presence in the reconstructed image by comparing the modified quotient to an artifact scale.

25. The method of claim 24 wherein the artifact scale has a maximum of ten and a minimum of one.

26. The method of claim 14 further comprising the step of filtering the imaging data with a two-dimensional array.

27. The method of claim 26 wherein the filtering two dimensional array includes a Hanning kernel.

28. The method of claim 26 wherein the filtering two dimensional array has a five by five orientation.

29. The method of claim 14 wherein the base value is a whole number.

30. The method of claim 29 wherein the base value is zero.

31. The method of claim 14 wherein the subject includes a phantom designed to simulate an anatomical region of a patient.

32. The method of claim 14 wherein the step of reconstructing an image having a plurality of pixels from imaging data acquired from the subject comprises acquiring the imaging data from a phantom using a CT scanner.

* * * * *

UNITED STATES PATENT AND TRADEMARK OFFICE
CERTIFICATE OF CORRECTION

PATENT NO. : 7,593,761 B1
APPLICATION NO. : 11/160027
DATED : September 22, 2009
INVENTOR(S) : Toth et al.

Page 1 of 1

It is certified that error appears in the above-identified patent and that said Letters Patent is hereby corrected as shown below:

On the Title Page:

The first or sole Notice should read --

Subject to any disclaimer, the term of this patent is extended or adjusted under 35 U.S.C. 154(b)
by 1143 days.

Signed and Sealed this

Twenty-eighth Day of September, 2010

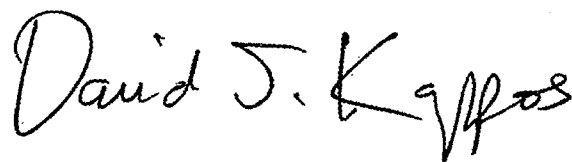
A handwritten signature in black ink that reads "David J. Kappos". The signature is written in a cursive style with a large initial "D" and a stylized "K".

David J. Kappos
Director of the United States Patent and Trademark Office