

V. J. WAHLSTROM.  
 CHUCK.  
 APPLICATION FILED OCT. 14, 1910.

996,955.

Patented July 4, 1911.

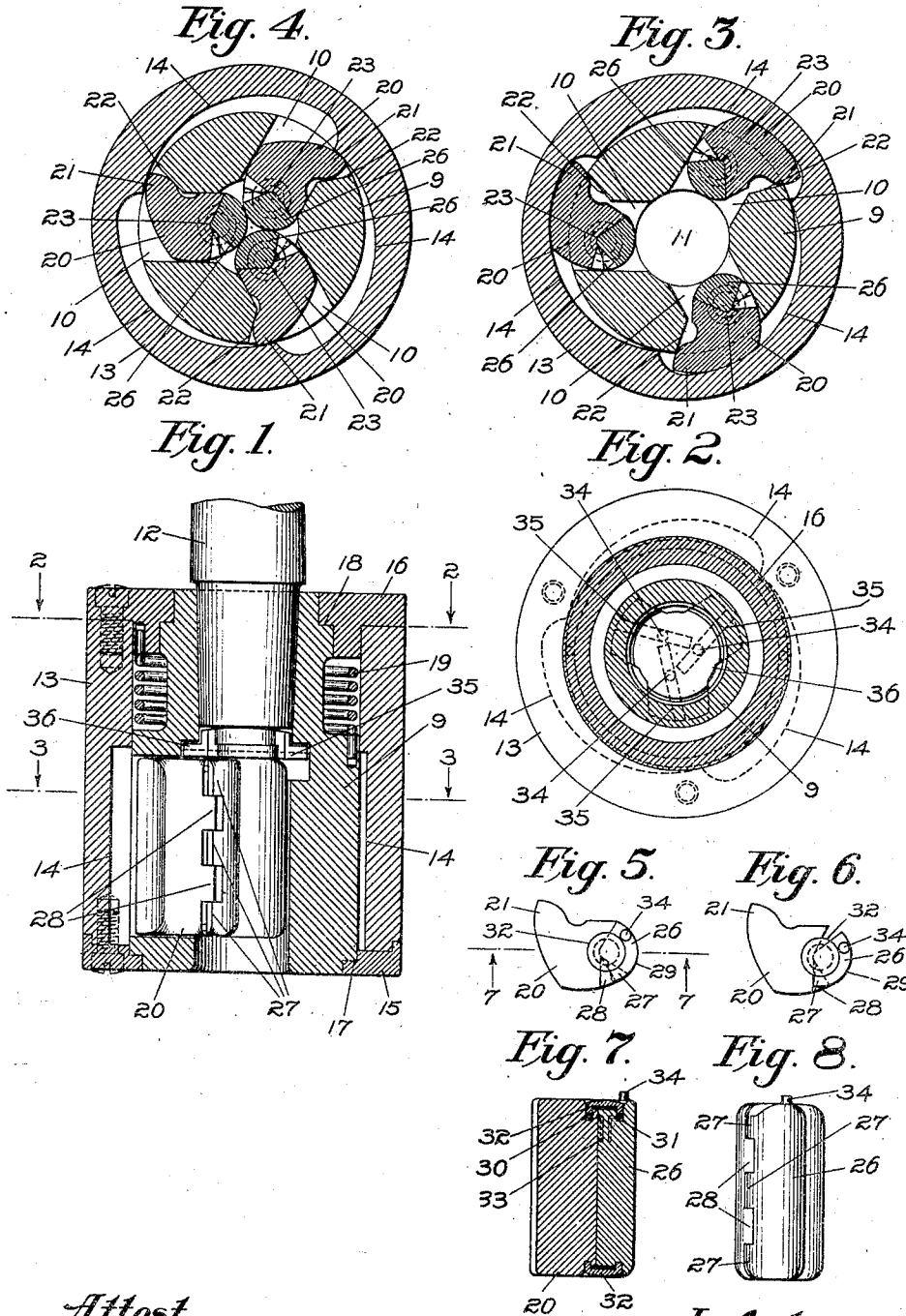

*Attest.*  
 Marcel J. Giel.  
 Grant H. Vick Jr.

*Inventor.*  
 Verner J. Wahlstrom  
 by Sydney Prescott & Co.

# UNITED STATES PATENT OFFICE.

VERNER J. WAHLSTROM, OF BROOKLYN, NEW YORK, ASSIGNOR OF ONE-HALF TO  
BERNHARD T. BURCHARDI, OF BROOKLYN, NEW YORK.

CHUCK.

996,955.

Specification of Letters Patent.

Patented July 4, 1911.

Application filed October 14, 1910. Serial No. 586,989.

*To all whom it may concern:*

Be it known that I, VERNER J. WAHLSTROM, a citizen of the United States, residing at Brooklyn, county of Kings, and State of New York, have invented a new and useful Improvement in Chucks, of which the following is a specification.

This invention relates to an improvement in chucks, and it has for its main objects the production of a device of this general character of increased capacity and efficiency.

With these and other objects not specifically mentioned in view, the invention consists in certain constructions and combinations which will be hereinafter fully described and then specifically pointed out in the claims hereunto appended.

In the accompanying drawings which form a part of this specification and in which like characters of reference indicate the same parts, Figure 1 is a central sectional view of a device constructed in accordance with the invention, Fig. 2 is a sectional view taken on the line 2—2 in Fig. 1, Figs. 3 and 4 are sectional views taken on the line 3—3 in Fig. 1, showing the jaws in different positions, Figs. 5 and 6 are plan views of one of the jaws showing the parts in different positions, Fig. 7 is a sectional view taken on the line 7—7 in Fig. 5, and Fig. 8 is an end elevation of the jaw shown in Figs. 5, 6 and 7.

In the device selected to illustrate the invention, there is provided a body 9 having three radial slots 10 cut through its wall to a central aperture 11 adapted to receive a tool shank. The body is further provided with a shank 12, driven or otherwise fastened in the body for the purpose of attaching the device to a drill press or other machine tool. The device is further provided with an annular shell 13 surrounding the body and rotatable thereon. This shell is provided with three internal cam faces 14, and is held in position by means of two caps 15, 16 screwed to the shell and engaging rabbets 17, 18 formed on the body 9. A spring 19 is coiled around the body within the shell, one end being fast to the body and the other to the shell, as indicated in Fig. 1.

That portion of the device so far described is old and well known in the art, and a more detailed description of its construction is deemed unnecessary to a full understand-

ing of the present invention, and is therefore omitted in the interest of brevity.

For the purpose of clamping a tool shank in the aperture 9, there is provided a jaw, or a plurality of jaws, working in the slot 10. This jaw, or these jaws, may vary within wide limits. As shown, however, what may be termed rocking jaws are employed. Each of these jaws, marked 20, is provided at its outer end with a hook 21 which is in engagement with a ledge 22 formed in one wall of each of the slots 10. By reference to Figs. 3 and 4, it will be readily understood that the hooked end of the jaws are wider than the slots in which the jaws work, and that the ledge 22 lies in a plane which does not intersect the axis of the body 9. When the shell 13 is rotated by the spring 19, the internal cam faces 14 slide by the outer end of the jaws 20 and tend to force them inward toward the axis of the chuck. The hooked end 21 of the jaws in contact with the ledge 22 prevents one side of the jaws from traveling inward as fast as the other. The effective result of this is a rocking movement of the jaw which serves to translate a small movement, initially set up by the internal cam faces, into a relatively large movement of the jaws toward the axis of the chuck. This can be best understood by an inspection of Figs. 3 and 4. In Fig. 3, the jaws are shown in wide open position. In Fig. 4, they are shown in their innermost position. It will be readily understood that they can only reach the latter position by being rocked and moved inward by the rocking movement.

While in certain constructions, the jaws alone might be relied upon to clamp the tool shank by direct contact; in the best constructions and as shown, a tool gripper carried by the jaw is employed. This gripper, marked 26, is a segmental rocking gripper and is seated in a recess 23 formed on the inner end of the jaw 20, as clearly shown in Figs. 3 and 4. It is provided with fingers 27 which interlock with fingers 28 on the jaw 20. The bearing face 29 of each gripper is cam shaped so that the grippers are, by contact with a tool shank, caused to tightly clamp a tool shank in the aperture 11 in a well known manner. The upper and lower ends of the jaws are provided with segmental channels 30 concentric with

the recess 23. Similarly, the upper and lower ends of the grippers are provided with segmental channels 31 registering with the channels 30. In these channels are fitted annular caps 32 which serve to hold the jaws and grippers pivotally together. For the purpose of holding each gripper in open or inoperative position, a spring 33 is employed. One end of this spring is secured in the jaw and the other in the gripper, Figs. 5 and 7.

When a plurality of jaws and grippers are employed, each gripper is provided with an upwardly projecting stud 34 which engages one of the slots 35 cut in the lower face of a plate 36 centrally located in the upper part of the aperture 11.

The mechanism just described serves to control the rocking movement of the several grippers and insure uniform movement of the same so that a tool shank will always be centrally clamped in the aperture.

In view of the foregoing, a detailed description of the operation of the device is deemed unnecessary and is therefore omitted in the interest of brevity.

Changes and variations may be made in the structure by means of which the invention is carried into effect. The invention, therefore, is not to be restricted to the precise details of the structure shown and described.

What is claimed is:

1. In a chuck, the combination with a body having a slot, of an annular shell surrounding the body and having an internal cam face, a jaw mounted and shaped to turn within the slot the outer end of said jaw lying in the path of the cam face, and means for limiting the movement of one side of the jaw to cause it to turn within the slot.

2. In a chuck, the combination with a body having a slot, of an annular shell surrounding the body and having an internal cam face, a jaw mounted and shaped to turn within the slot and having at its outer end a hook wider than the slot and lying in the path of the cam face, and means in the path of the hook to limit its movement whereby the jaw is caused to turn in the slot.

3. In a chuck, the combination with a body having a slot, of an annular shell surrounding the body and having an internal cam face, a jaw mounted and shaped to turn within the slot and having at its outer end

an integral hook wider than the slot and lying in the path of the cam face, and means in the path of the hook to limit its movement whereby the jaw is caused to turn in the slot.

4. In a chuck, the combination with a body having a slot, of an annular shell surrounding the body and having an internal cam face, a jaw mounted and shaped to turn within the slot and having at its outer end an integral hook wider than the slot and lying in the path of the cam face, and means at one side of the slot and in the path of the hook to limit the movement of the hook whereby the jaw is caused to turn in the slot.

5. In a chuck, the combination with a body having a slot, of an annular shell surrounding the body and having an internal cam face, a jaw mounted and shaped to turn within the slot and having at its outer end an integral hook wider than the slot and lying in the path of the cam face, and a ledge at one side of the slot and in the path of the hook to limit the movement of the hook whereby the jaw is caused to turn in the slot.

6. In a chuck, the combination with a body having a radial slot provided at one side with a ledge wider than the slot, of an annular shell surrounding the body and having an internal cam face, a jaw working in the slot and having at its outer end a hook wider than the slot and lying in the path of the cam face with its end in engagement with the ledge, and a tool gripper pivotally carried by the jaw.

7. In a chuck, the combination with a body having a radial slot provided at one side with a ledge wider than the slot and lying in a plane that does not intersect the axis of the body, of an annular shell surrounding the body and having an internal cam face, a jaw working in the slot and having at its outer end a hook wider than the slot and lying in the path of the cam face with its end in engagement with the ledge, and a tool gripper pivotally carried by the jaw.

In testimony whereof, I have signed my name to this specification in the presence of two subscribing witnesses.

VERNER J. WAHLSTROM

Witnesses:

J. D. H. BERGEN,

H. OTTO CLAUSSEN.