

J. W. Post. Paddle Wheel.

N^o 108,626.

Patented Oct. 25, 1870.

Fig. 1.

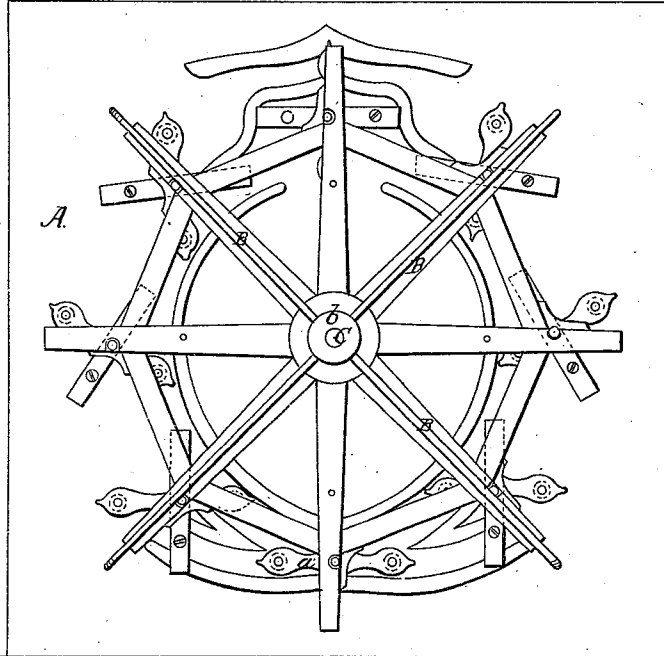
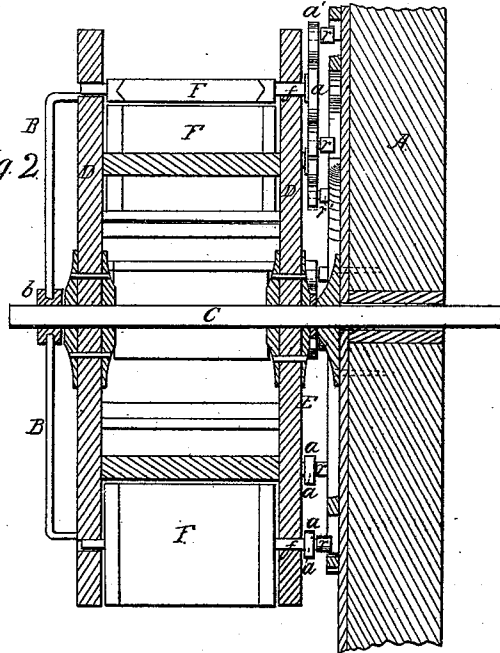

Fig. 2.



Witnesses:

Henry J. Metz,

Samuel Smith

Inventor:

J. W. Post

Atty: A. C. Staucke & Co.
Per A. Horrocks

J. W. Post. Paddle Wheel.

N^o: 108,626.

Patented Oct. 25, 1870.
Fig 3.

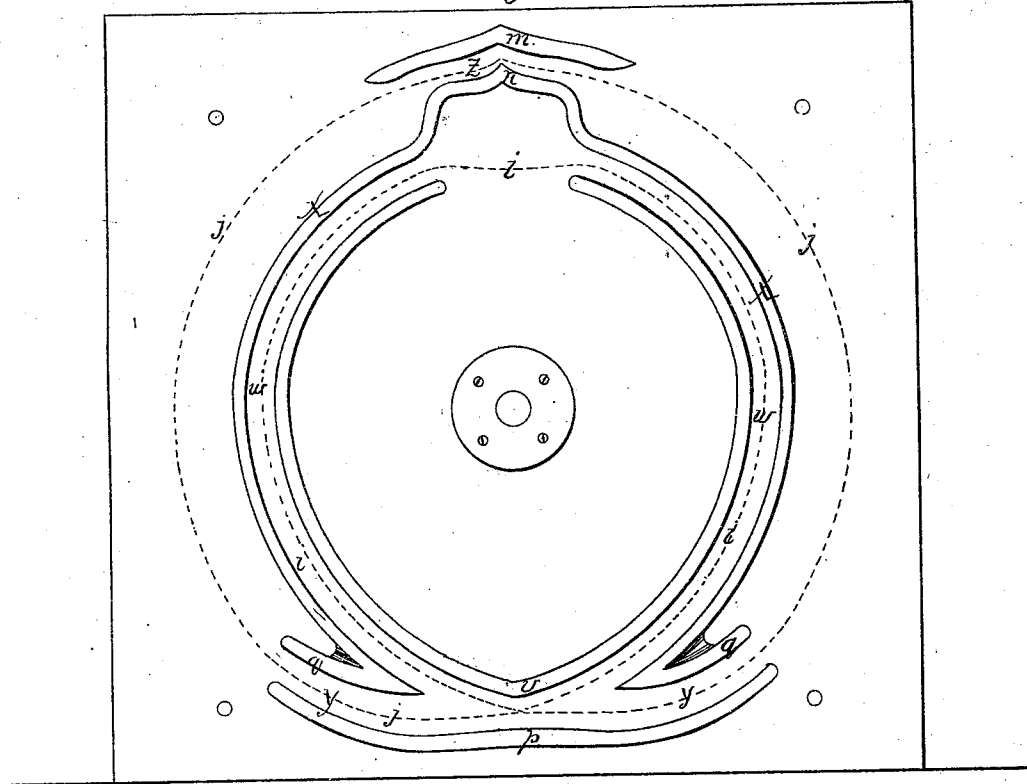
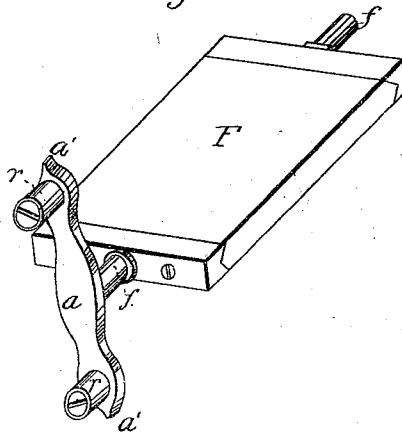

Fig. 4



Witnesses:

Henry J. Archy
Samuel Smith

INVENTOR:

John W Post
By: A. C. Blaucker & Co
his Attorneys

United States Patent Office.

JOHN W. POST, OF CASTILE, PENNSYLVANIA.

Letters Patent No. 108,626, dated October 25, 1870; antedated October 11, 1870.

IMPROVEMENT IN PADDLE-WHEELS.

The Schedule referred to in these Letters Patent and making part of the same

To all whom it may concern:

Be it known that I, JOHN W. POST, of Castile, in the county of Wyoming and State of Pennsylvania, have invented a new and useful Improvement in Paddle-Wheels; and I do hereby declare the following to be a full and correct description of the same, sufficient to enable others skilled in the art to which my invention appertains to fully understand and construct the same, reference being had to the accompanying drawing which makes part of this specification, and in which—

Figure 1 is a side elevation of my improved paddle-wheel.

Figure 2 is a vertical central cross-section of the same.

Figure 3 is a view showing the way or grooves in which the rollers guiding the paddles move.

Figure 4 is a perspective view of one of the paddles.

Like letters of reference indicate like parts in the several figures.

The nature of my invention consists in providing one of the ends of the paddle-shafts, outside of the wheel-arms, with a double roller-arm, secured at right angles to the width of the paddle, the rollers of which arm move in grooves or ways, so arranged that at least one of the rollers is continually held between two parts of the groove or way, in such a manner as to give firmness to the paddle, in whatever position, in or out of the water, it may be, at the same time giving it the requisite feather.

The great advantage obtained by my device is, that no depressions or projections in the groove or way present themselves to the rollers over which the latter have to be forced, thereby creating great friction, and consequent loss of power.

By my arrangement I also do away with unnecessary leverage and complication.

In the drawing—

A may represent the side of a vessel, to which a frame, B, is secured, in which, at *b*, is the outer bearing of the paddle-wheel shaft C.

The paddle-wheel consists of a double series of arms, D E, between which are pivoted the paddles F, their shafts, *f*, passing through the arms D E, near their outer ends, and being provided, between the arms E and the side of the vessel, with a double arm, *a*, carrying inwardly-projecting rollers, *r r'*, one at each end.

This arm *a* is formed or otherwise secured on the shafts *f*, at right angles to the width of the paddles, and its ends terminate in points, *a'*.

In fig. 3, I have shown the groove or way in which

the rollers *r r'* move to operate the feathering of and to steadily hold the paddles.

The main groove or way, *w*, is traversed, during each revolution of the wheel, by one of the rollers, while the other roller traverses the distance outside of the way or groove, and effects the changes through the additional way-pieces *m, p*, and *q*.

The way *w* is formed by a continuous piece, *v*, open only at the top, and another continuous piece, *x*, open below, and provided at each end with an outwardly-extending way-piece, *g*, which, with the additional separate way-piece *p*, forms an additional groove, *y*, the same being, so to speak, tangential to the groove *w*.

The continuous piece, *x*, bulges out at the top, and comes to a point, as shown at *n*, and forms, with a correspondingly-shaped piece, *m*, a groove, *z*.

I have shown in dotted lines in fig. 3 the course of the two rollers during each revolution, commencing, for illustration, at the point of intersection.

I will name the line in groove *w* *i*, and the other dotted line *j*.

Supposing the roller *r* to follow the line *i*, and the roller *r'* the line *j*, the operation will be as follows:

When roller *r* starts from the point of intersection, the roller *r'* is already in groove *y*, holding the paddle, and both rollers move on, gradually bringing the arm *a* to a vertical position.

When the point *a'* has entered groove *z*, it is brought into the point of the groove, and there forms the point for roller *r* to move across the open space, thus giving at the same time about a quarter revolution to the paddle.

Both rollers now move on down the other side, and, at the point of intersection, the roller *r* turns from the groove *w* into the groove *y*, while the roller *r'* passes from the other end of groove *y* into the groove *w*, the arm *a* having a horizontal position during this movement.

It will be easily seen that, in each two revolutions of the wheel, the paddle makes one complete revolution around its own axis, and that, by the arrangement of the grooves, the paddles are not only properly feathered, but the paddles held continually firm and steady by one of the rollers, while the other roller performs the change of positions of the arm and paddle.

It is obvious that the grooves *w y z* may be formed on the surface of the sides of the vessel by metal strips secured to the same, but they may be formed by cutting them in the sides of the vessel, and properly lining them.

Having thus described my invention,
What I claim, and desire to secure by Letters
Patent, is—

1. The paddles *F*, when provided with double roller-arms, *a*, constructed substantially as described, and operating in the grooves *w y z*, for the purposes substantially as set forth.
2. The arrangement of the grooves *w y z*, substantially as and for the purposes set forth.

The above specification of my improvement in
paddle-wheels signed this 29th day of December,
1869.

JOHN W. POST.

Witnesses :

HENRY A. JOHNSTON,
HENRY J. ARETZ.