

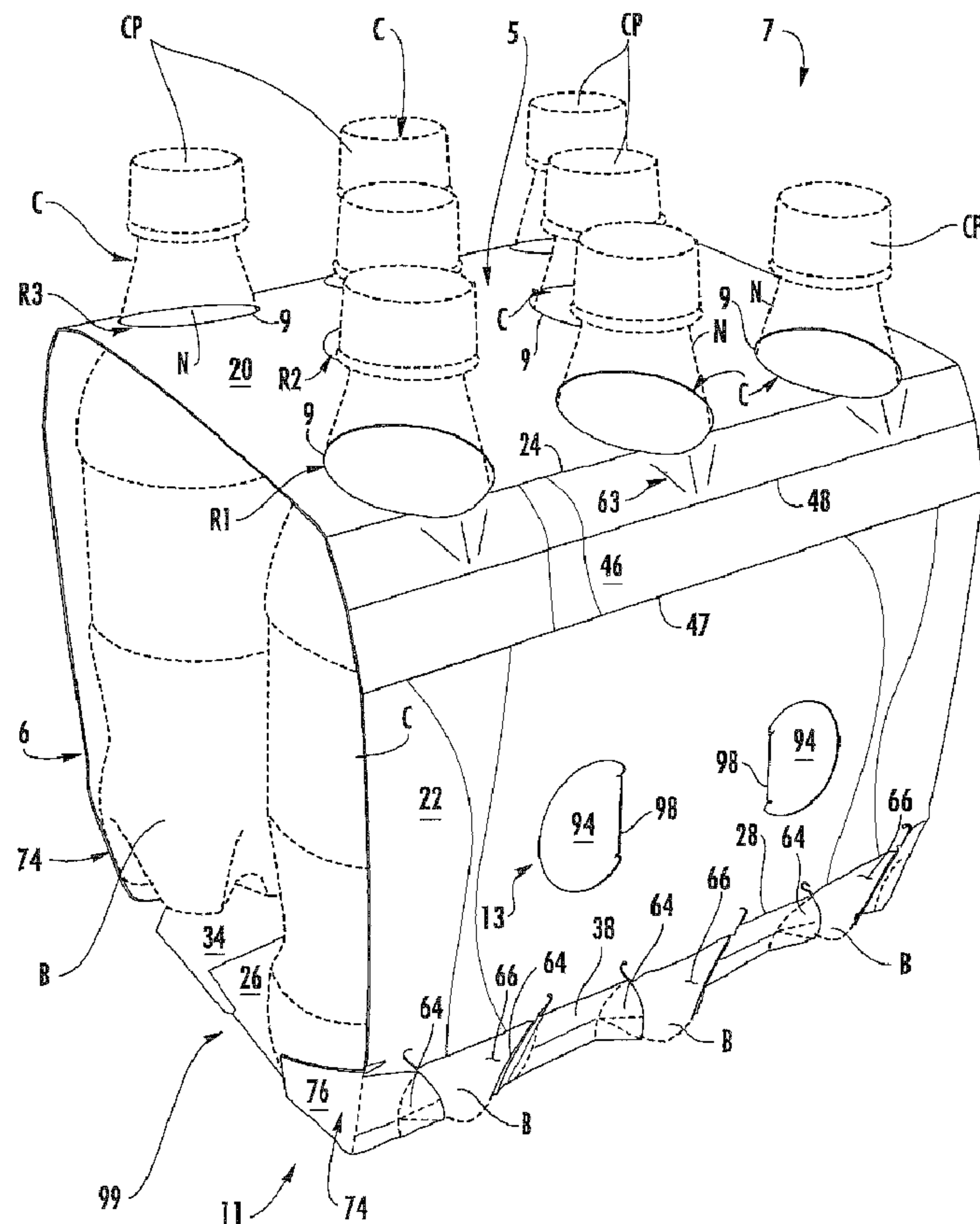

(86) **Date de dépôt PCT/PCT Filing Date:** 2015/10/06  
 (87) **Date publication PCT/PCT Publication Date:** 2016/04/14  
 (45) **Date de délivrance/Issue Date:** 2019/02/12  
 (85) **Entrée phase nationale/National Entry:** 2017/03/23  
 (86) **N° demande PCT/PCT Application No.:** US 2015/054176  
 (87) **N° publication PCT/PCT Publication No.:** 2016/057476  
 (30) **Priorité/Priority:** 2014/10/08 (US62/122,022)

(51) **Cl.Int./Int.Cl. B65D 71/14** (2006.01),  
**B65D 71/16** (2006.01)  
 (72) **Inventeurs/Inventors:**  
SPIVEY, RAYMOND R. SR., US;  
MAY, KEVIN T., US  
 (73) **Propriétaire/Owner:**  
GRAPHIC PACKAGING INTERNATIONAL, LLC, US  
 (74) **Agent:** MACRAE & CO.

(54) **Titre : SUPPORT COMPORTANT DES FONCTIONNALITES DE RECEPTION ET DE RETENTION**  
 (54) **Title: CARRIER WITH RECEIVING AND RETENTION FEATURES**



(57) **Abrégé/Abstract:**

A carrier for at least partially holding a plurality of articles can comprise a plurality of panels that can comprise at least a top panel, a side panel, and a bottom panel. A plurality of article receiver features can be disposed in at least the top panel in at least a first row

(57) **Abrégé(suite)/Abstract(continued):**

and a second row. The first row can comprise at least one more article receiver feature than the second row. Each article receiver feature of the plurality of article receiver features can be for at least partially receiving a respective article of the plurality of articles. A retention feature can extend in at least one of the side panel and the bottom panel. The retention feature can be for at least partially retaining at least one article that is at least partially received in a respective one of the article receiving features in the first row.

(12) INTERNATIONAL APPLICATION PUBLISHED UNDER THE PATENT COOPERATION TREATY (PCT)

(19) World Intellectual Property  
Organization  
International Bureau(10) International Publication Number  
**WO 2016/057476 A1**(43) International Publication Date  
14 April 2016 (14.04.2016)

- (51) International Patent Classification:  
*B65D 71/14* (2006.01)    *B65D 71/16* (2006.01)
- (21) International Application Number:  
PCT/US2015/054176
- (22) International Filing Date:  
6 October 2015 (06.10.2015)
- (25) Filing Language: English
- (26) Publication Language: English
- (30) Priority Data:  
62/122,022    8 October 2014 (08.10.2014)    US
- (71) Applicant: GRAPHIC PACKAGING INTERNATIONAL, INC. [US/US]; Law Department - 9th Floor, 1500 Riveredge Parkway, Suite 100, Atlanta, GA 30328 (US).
- (72) Inventors: SPIVEY, Raymond, R., Sr.; 475 Ivey Court, Mableton, GA 30126 (US). MAY, Kevin, T.; 512 Earlvine Way, Kennesaw, GA 30152 (US).
- (74) Agent: CLAERBOUT, Andrew, N.; Womble Carlyle Sandridge & Rice LLP, P.O. Box 7037, Atlanta, GA 30357-0037 (US).
- (81) Designated States (*unless otherwise indicated, for every kind of national protection available*): AE, AG, AL, AM, AO, AT, AU, AZ, BA, BB, BG, BH, BN, BR, BW, BY, BZ, CA, CH, CL, CN, CO, CR, CU, CZ, DE, DK, DM, DO, DZ, EC, EE, EG, ES, FI, GB, GD, GE, GH, GM, GT, HN, HR, HU, ID, IL, IN, IR, IS, JP, KE, KG, KN, KP, KR, KZ, LA, LC, LK, LR, LS, LU, LY, MA, MD, ME, MG, MK, MN, MW, MX, MY, MZ, NA, NG, NI, NO, NZ, OM, PA, PE, PG, PH, PL, PT, QA, RO, RS, RU, RW, SA, SC, SD, SE, SG, SK, SL, SM, ST, SV, SY, TH, TJ, TM, TN, TR, TT, TZ, UA, UG, US, UZ, VC, VN, ZA, ZM, ZW.
- (84) Designated States (*unless otherwise indicated, for every kind of regional protection available*): ARIPO (BW, GH, GM, KE, LR, LS, MW, MZ, NA, RW, SD, SL, ST, SZ, TZ, UG, ZM, ZW), Eurasian (AM, AZ, BY, KG, KZ, RU, TJ, TM), European (AL, AT, BE, BG, CH, CY, CZ, DE, DK, EE, ES, FI, FR, GB, GR, HR, HU, IE, IS, IT, LT, LU,

[Continued on next page]

(54) Title: CARRIER FOR CONTAINERS

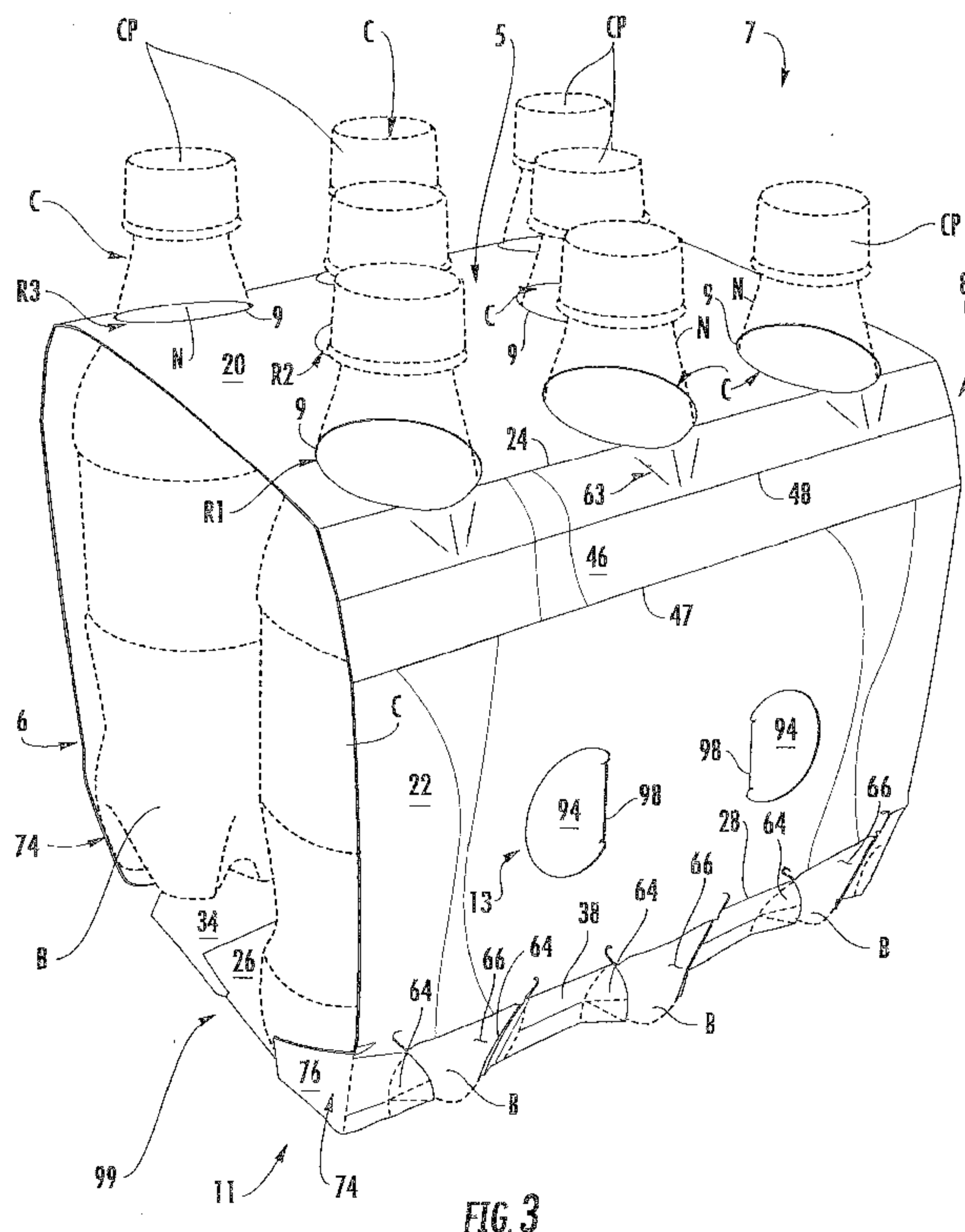

(57) Abstract: A carrier for at least partially holding a plurality of articles can comprise a plurality of panels that can comprise at least a top panel, a side panel, and a bottom panel. A plurality of article receiver features can be disposed in at least the top panel in at least a first row and a second row. The first row can comprise at least one more article receiver feature than the second row. Each article receiver feature of the plurality of article receiver features can be for at least partially receiving a respective article of the plurality of articles. A retention feature can extend in at least one of the side panel and the bottom panel. The retention feature can be for at least partially retaining at least one article that is at least partially received in a respective one of the article receiving features in the first row.

WO 2016/057476 A1

**WO 2016/057476 A1** 

---

LV, MC, MK, MT, NL, NO, PL, PT, RO, RS, SE, SI, SK,  
SM, TR), OAPI (BF, BJ, CF, CG, CI, CM, GA, GN, GQ,  
GW, KM, ML, MR, NE, SN, TD, TG).

— *as to the applicant's entitlement to claim the priority of  
the earlier application (Rule 4.17(iii))*

**Declarations under Rule 4.17:**

— *as to applicant's entitlement to apply for and be granted  
a patent (Rule 4.17(ii))*

**Published:**

— *with international search report (Art. 21(3))*

## CARRIER WITH RECEIVING AND RETENTION FEATURES

[0001]

[0002]

### BACKGROUND OF THE DISCLOSURE

[0003] The present disclosure generally relates to carriers for holding and dispensing beverage containers or other types of articles.

### SUMMARY OF THE DISCLOSURE

[0004] In general, one aspect of the disclosure is directed to a carrier for at least partially holding a plurality of articles. The carrier can comprise a plurality of panels that extends at least partially around an interior of the carrier. The plurality of panels can comprise at least a top panel, a side panel, and a bottom panel. A plurality of article receiver features can be disposed in at least the top panel in at least a first row and a second row. The first row can comprise at least one more article receiver feature than the second row. Each article receiver feature of the plurality of article receiver features can be for at least partially receiving a respective article of the plurality of articles. A retention feature can extend in at least one of the side panel and the bottom panel. The retention feature can be for at least partially retaining at least one article that is at least partially received in a respective one of the article receiving features in the first row.

[0005] In another aspect, the disclosure is generally directed to a blank for forming a carrier for holding a plurality of articles. The blank can comprise A plurality of panels comprising at least a top panel, a side panel, and a bottom panel. A plurality of article receiver features can be disposed in at least the top panel in at least a first row and a second row. The first row can comprise at least one more article receiver feature than the second row, and each article receiver feature of the plurality of article receiver features can be for at least partially receiving a respective article of the plurality of articles when the carrier is formed from the blank. A retention feature can extend in at least one of the side panel and the bottom panel. The retention feature can be for at least partially retaining at least one article that is at least partially received in a respective one of the article receiving features in the first row when the carrier is formed from the blank.

[0006] In another aspect, the disclosure is generally directed to a package comprising a carrier having substantially open ends. The carrier can comprise a plurality of panels that extends at least partially around an interior of the carrier. The package further can comprise a plurality of articles at least partially disposed in the interior of the carrier. The articles of the plurality of articles can be arranged in at least a first row and a second row, and the first row can comprise at least one more article than the second row.

[0007] In another aspect, the disclosure is directed to a method of forming a package comprising obtaining a plurality of articles and a blank comprising a plurality of panels, and arranging the articles of the plurality of articles in at least a first row and a second row. The first row can comprise at least one more article than the second row. The method also can comprise forming a carrier from the blank by wrapping the plurality of panels at least partially around the plurality of articles. The carrier can have substantially open ends.

[0008] Other aspects, features, and details of the present disclosure can be more completely understood by reference to the following detailed description of exemplary embodiments taken in conjunction with the drawings.

[0009] Those skilled in the art will appreciate the above stated advantages and other advantages and benefits of various additional embodiments reading the following detailed description of the embodiments with reference to the below-listed drawing figures. Further, the various features of the drawings discussed below are not necessarily drawn to scale. Dimensions of various features and elements in the drawings may be expanded or reduced to more clearly illustrate the embodiments of the disclosure.

**BRIEF DESCRIPTION OF THE DRAWINGS**

- [0010] Fig. 1 is a plan view of an exterior surface of a blank used to form a carrier according to a first embodiment of the disclosure.
- [0011] Fig. 2 is a detail view of a portion of the blank of Fig. 1 showing retention features according to the first embodiment of the disclosure.
- [0012] Fig. 3 is a perspective view of a package including the carrier formed from the blank of Fig. 1 and nested containers according to the first embodiment of the disclosure.
- [0013] Fig. 4 is an end view of the package of Fig. 3.
- [0014] Figs. 5 and 6 are bottom views of the package of Fig. 3.
- [0015] Fig. 7 is a plan view of an exterior surface of a blank used to form a carrier according to a second embodiment of the disclosure.
- [0016] Fig. 8 is a plan view of an exterior surface of a blank used to form a carrier according to a third embodiment of the disclosure.
- [0017] Fig. 9 is a plan view of an exterior surface of a blank used to form a carrier according to a fourth embodiment of the disclosure.
- [0018] Corresponding parts are designated by corresponding reference numbers throughout the drawings.

**DETAILED DESCRIPTION OF THE EXEMPLARY EMBODIMENTS**

- [0019] The present disclosure generally relates to various features for cartons or carriers that contain articles such as containers, bottles, cans, etc. The articles can be used for packaging food and beverage products, for example. The articles can be made from materials suitable in composition for packaging the particular food or beverage item, and the materials include, but are not limited to, aluminum and/or other metals; glass; plastics such as PET, LDPE, LLDPE, HDPE, PP, PS, PVC, EVOH, and Nylon; and the like, or any combination thereof.

[0020] Cartons or carriers according to the present disclosure can accommodate articles of any shape. For the purpose of illustration and not for the purpose of limiting the scope of the disclosure, the following detailed description describes beverage containers (e.g., plastic beverage bottles) as disposed within the carrier embodiments. In this specification, the terms “inner,” “interior,” “outer,” “exterior,” “lower,” “bottom,” “upper,” and “top” indicate orientations determined in relation to fully erected and upright cartons.

[0021] Fig. 1 is a plan view of an exterior surface 2 of a blank 3, used to form a carrier 5 (Fig. 3) according to a first embodiment of the disclosure. In the illustrated embodiment, the carrier 5 is a carrier having generally open ends 6, 8 that wraps around the containers C (e.g., the carrier 5 may be referred to as a wrap-around carton or carrier). The carrier 5 could be otherwise shaped and arranged such that the ends 6, 8 are at least partially closed such as by end flaps (not shown) or other closing mechanisms. The carrier 5 can be used to house a plurality of articles such as containers C (Figs. 3-6) to form a package 7 (Fig. 3). In the illustrated embodiment, the containers C are beverage bottles having a wide bottom B and a narrow top or neck N including a cap CP. The carrier 5 can be sized to house eight containers in a single layer in a “nested” arrangement having two outer rows of three bottles per row and one inner row of two bottles. In one embodiment, the nesting of the containers C in the carrier 5 allows the carrier to hold the containers in more than two rows since the outer rows can help retain the inner row that is nested with the outer rows. In the illustrated embodiment, the carrier 5 can include retention features including article receiver features 9 for receiving the upper portions N of the containers C and bottom retention features 11 for engaging the bottom portions B of the containers C that are disposed adjacent the sides of the carrier 5. In addition, the carrier 5 can include one or two handles, generally indicated at 13, for grasping and carrying the carrier.

[0022] Various other nested bottle arrangements could be used with the first embodiment, or other illustrated and non-illustrated embodiments of the disclosure. Alternative nested pack arrangements can include an arrangement with eleven bottles with two outer rows of four bottles per row and one inner row of three bottles, an arrangement with ten bottles with two outer rows of three bottles per row and two inner rows of two bottles per row, etc. In one embodiment, such nesting arrangements can be considered “internal nesting arrangements” since the interior row(s) of containers are generally shorter than the outer rows of containers (e.g., the outer rows have one more container each than the inner row(s)). Other nested or non-nested arrangements of the containers could be provided without departing from the disclosure. For example, the inner row(s) could be longer than the outer rows in an alternative embodiment. In another

embodiment, an arrangement with thirteen containers can have two outer rows with three bottles per row, two inner rows with two bottles per row, and a central row with three bottles disposed between the two inner rows, for example. In the different arrangements, the containers can be nested in an at least partially staggered arrangement so that the containers in the inner row(s) are generally offset from the containers in the outer rows, as generally shown in Figs. 3 and 4. The containers C could be otherwise arranged without departing from the disclosure.

[0023] The blank 3 has a longitudinal axis L1 and a lateral axis L2. In the illustrated embodiment, the blank 3 comprises a top panel 20 foldably connected to a first side panel 22 at a first lateral fold line 24, a first bottom panel 26 foldably connected to the first side panel 22 at a second lateral fold line 28, a second side panel 30 foldably connected to the top panel 20 at a third lateral fold line 32, and a second bottom panel 34 foldably connected to the second side panel 30 at a fourth lateral fold line 36. In the illustrated embodiment, the first bottom panel 26 includes a first bottom bevel panel 38 defined by lateral fold lines 28 and 40 and having an intermediate fold line 41. The second bottom panel 34 includes a second bottom bevel panel 42 defined by lateral fold lines 36 and 44 and having an intermediate fold line 45. The lateral fold lines 40, 44 can include multiple segments each, wherein a longitudinal cut is disposed at each end of each segment. In the illustrated embodiment, the first side panel 22 can include a first top bevel panel 46 defined by lateral fold lines 24 and 47 and having an intermediate fold line 48, and the second side panel 30 can include a second top bevel panel 49 defined by lateral fold lines 32 and 50 and having an intermediate fold line 51. The blank 3 could be otherwise shaped, arranged, positioned, and/or configured without departing from the disclosure. For example, any of the bevel panels 38, 42, 46, 49 could be omitted or otherwise shaped, arranged, positioned, and/or configured without departing from the disclosure.

[0024] The first bottom panel 26, which is the inner bottom panel in the assembled carrier 5, includes cutouts forming primary female locking edges 52 that are shaped and positioned to engage primary male locking tab projections 54 on the second bottom panel 34. The first bottom panel 26 also includes slits 56 shaped and positioned to receive outer secondary locking tab projections 58 of the second bottom panel 34. As shown in Fig. 1, the slits 56 can define tabs that are foldably connected to the first bottom panel 26. In the illustrated embodiment, the second bottom panel 34, which is the outer bottom panel in the completed carrier 5, includes a lateral fold line 60, which can be interrupted by the slits that define the primary male locking tab projections 54. In addition, each of the secondary locking tab projections 58 can include a lateral fold line 62. Although the locking elements of the blank 3 are illustrated to demonstrate a

particular bottom panel locking arrangement suitable for use with the carrier 5, it is understood that any alternative form of bottom panel locking structure may be employed without departing from the disclosure. Additionally, or alternatively, the bottom panels 26, 34 could be glued together.

[0025] As shown in Fig. 1, the article receiver features 9 are top openings 9 that can be formed in the top panel 20 in three rows R1, R2, R3, in one embodiment. In other embodiments, the top openings 9 can be formed in different arrangements to accommodate the different container arrangements described above. The outer rows R1, R3 can include three top openings 9 each, and the inner row R2 can include two top openings 9 that are offset from the top openings 9 in the outer rows R1, R3. In the illustrated embodiment, the top openings 9 in the inner row R2 are offset from the remaining openings so that each of the top openings 9 in the inner row R2 has a center A that is disposed generally halfway between two of the top openings 9 in the outer rows R1, R3. Accordingly, the top openings 9 in the inner row R2 are positioned with respect to the top openings 9 in the outer rows R1, R3 so that the openings are in a staggered arrangement and the containers C that are received in the top openings 9 in the inner row R2 are nested with the containers C that are received in the top openings 9 in the outer rows R1, R3 (Figs. 3 and 4). In one embodiment, the top openings 9 in the outer rows R1, R3 can partially interrupt the respective lateral fold lines 24, 32, and cuts 63 can extend in the top bevel panels 46, 49 adjacent the outer openings. Any of the article receiver features or top openings 9 and/or the rows R1, R2, R3 could be omitted or could be otherwise positioned, shaped, configured, and/or arranged without departing from the disclosure. For example, the article receiver features could comprise tabs, flaps, and/or other features in addition to or instead of the top openings 9.

[0026] In one embodiment, the bottom retention features 11 in the first side panel 22 and the first bottom panel 26 are shown in detail in Fig. 1A; however, the bottom retention features 11 in the second side panel 30 and the second bottom panel 34 are similar or substantially identical to the bottom retention features 11 in the first side panel 22 and the first bottom panel 26 as shown in Fig. 1. As shown in Figs. 1 and 1A, the bottom retention features 11 can include two retention tabs 64 adjacent a respective bottom or corner opening 66 for each of the containers C in the outer row R1. Each of the retention tabs 64 can be foldably connected to the bottom bevel panel 38 along a respective fold line 68 and can include V-shaped folds 70. A hook-shaped cut 72 can extend from each of the retention tabs 64 into the first side panel 22 for allowing additional folding and/or flexing of the tabs 64 and/or the side panel 22 to accommodate the respective container C.

[0027] As shown in Figs. 1 and 1A, the bottom retention features 11 can include a corner retainer 74 at each end of the bottom panels 26, 34. As shown in Fig. 1A, each of the corner retainers 74 can include a retention panel 76 foldably connected to the bottom bevel panel 38 along a longitudinal fold line 78, a first gusset panel 80 foldably connected to the retention panel 76 along a lateral fold line 82, and a second gusset panel 84 foldably connected to the first gusset panel along a longitudinal fold line 86. Each of the second gusset panels 84 can be foldably connected to the first bottom panel 26 along a respective oblique fold line 88 and can be separable from the first bottom panel 26 along a respective cut line 90. Each of the corner retainers 74 can at least partially define a cutout 92 in one embodiment. Any of the bottom retention features 11, including the retention tabs 64, the corner openings 66, and/or the corner retainers 74 could be omitted or could be otherwise shaped, arranged, positioned, and/or configured without departing from the disclosure.

[0028] As shown in Figs. 1 and 1A, each of the handles 13 includes two finger flaps 94, each respectively formed by a respective curved cut line 96 and foldably attached to the respective side panel 22, 30 at a respective longitudinal fold line 98. The handles 13 could include other features for carrying the carrier 5, any of the finger flaps 94 could be omitted or could be otherwise positioned, shaped, configured, and/or arranged, or one or both of the handles 13 could be omitted from the carrier without departing from the disclosure.

[0029] As shown in Fig. 3, the carrier 5 can be erected by wrapping the blank 3 around the containers C and interlocking the first and second bottom panels 26, 34 to form the package 7. Particularly, the containers C can be arranged into the staggered, nested arrangement of the two outer rows R1, R3 of three containers C each and one inner row R2 of two containers C. The blank 3 can be positioned in relation to the arranged containers C so that each of the top openings 9 is generally aligned with a respective one of the containers C. The blank 3 and/or the containers C can be moved so that the blank 3 and the containers C are moved together and at least the upper portions N of the containers C are received in the respective top openings 9. The side panels 22, 30 can be downwardly folded along the fold lines 24, 32, and the top bevel panels 46, 49 can fold along the respective fold lines 47, 48 and 50, 51 to at least partially accommodate the shoulders of the containers C in the outer rows R1, R3.

[0030] In one embodiment, as the bottom panels 26, 34 are folded inwardly toward one another, the bottoms B of the containers C in the outer rows R1, R3 can be at least partially received in the respective corner openings 66 to engage the respective retention tabs 64. Also, while the bottom panels 26, 34 are folded along lateral fold lines 28, 36, the bottom bevel panels 38, 42 can fold along the respective fold lines 40, 41 and 44, 45 to extend obliquely between the side panels 22, 30 and the remainder of the bottom panels 26, 34. As shown in Figs. 3-6, the corner retainers 74 can be folded inwardly to position the gusset panels 80, 84 in face-to-face contact with one another and to tuck in the gusset panels 80, 84 between the respective bottom panel 26, 34 and the bottom B of a respectively adjacent container C (Figs. 5 and 6) so that the respective retention panel 76 extends over a portion of an end of the carrier 5 (Figs. 4 and 5). Accordingly, the retention tabs 64 and the corner openings 66 can help retain the respective containers C in the outer rows R1, R3 in place adjacent the respective side panels 22, 30, and the corner retainers 74 can help retain the containers C at the ends of the outer rows R1, R3 adjacent the open ends 6, 8 of the carrier 5.

[0031] In the illustrated embodiment, as shown in Figs. 5 and 6, the second bottom panel 34 is secured to the first bottom panel 26 by first folding the second bottom panel 34 along the lateral fold line 60 to at least partially separate the primary male locking tabs 54 from the second bottom panel 34 and respectively engaging the primary male locking tabs 54 with the primary female locking edges 52 (Figs. 4 and 5). The secondary male locking flaps 58 are respectively inserted through, and cooperatively interact with, the slits 56 to further secure the second bottom panel 34 to the first bottom panel 26. The interlocked bottom panels 26, 34 cooperate to form a bottom panel 99 of the carrier 5. The carrier 5 could be erected and/or the package 7 could be formed by alternative steps without departing from the disclosure.

[0032] In one embodiment, one or both of the handles 13 can be actuated by folding the finger flaps 94 inwardly along the respective fold lines 98 for grasping the respective side panel 22, 30 at the respective openings formed therein. The package 7 could be otherwise carried without departing from the disclosure.

[0033] In the illustrated embodiment, the nested arrangement of the containers can help the wrap-style carrier 5 to hold the containers in the three rows R1, R2, R3. For example, the nested configuration can allow the containers in the outer rows R1, R3 to retain the containers in the inner row R2 in the interior of the carrier. The containers C adjacent the ends of the carrier 5 in the outer rows R1, R3 interfere with the containers in the inner row R2 so that containers in the

inner row would have to push past the outer, end containers to be forced out of the carrier prior to intended removal. The containers in the outer rows are further retained by retention tabs 64, the corner openings 66, and the corner retainers 74. Accordingly, while the containers C in the inner row R2 are spaced from the side panels 22, 30 and the retention features 11, they are at least partially retained by the respective top openings 9 in the top panel 20 and the respectively nested containers C in the outer rows R1, R3. In one embodiment, a non-nested inner row in an alternative carrier with more than two rows will generally fail. For example, it can be more difficult to retain the containers in the inner row if they are not nested with and retained by the containers in the outer row. If one or more containers is unintentionally removed from (e.g., falls out of) the alternative carrier, the alternative carrier could collapse, some or all of the containers could fall out of the alternative carrier, and/or the alternative carrier could otherwise fail. Additionally, the nested arrangement of the containers C can be generally narrower than an arrangement with aligned rows that are not nested, and the amount of material added to the blank 3 to include the third row (e.g., the inner row) is less than would be required if the containers were arranged in three non-nested rows. Further, the carrier 5 can be more noticeable on a shelf by having a different look than other cartons and carriers, in one embodiment.

[0034] Fig. 7 is a plan view of an exterior surface 202 of a blank 203 for forming a carrier (not shown) according to a second embodiment of the disclosure. The second embodiment is generally similar to the first embodiment, except for variations noted and variations that will be apparent to one of ordinary skill in the art. Accordingly, similar or identical features of the embodiments have been given like or similar reference numbers. As shown in Fig. 7, the blank 203 includes alternative bottom retention features 211 wherein the corner retainers 74 of the first embodiment are omitted, and the retention tabs 264 are generally larger so that the openings are substantially closed prior to the formation of the package (not shown). Accordingly, the retention tabs 264 are separable from one another along respective longitudinal cut lines 267 and from the respective side panels 222, 230 and the respective bottom panels 226, 234 along respective lateral cut lines 269. Each of the retention tabs 264 can be connected to the respective side panels 222, 230 and the respective bottom panels 226, 234 along two oblique fold lines 268 in one embodiment. Additionally, each of the retention tabs 264 can include a V-shaped fold 270. As shown in Fig. 7, the lateral fold lines 228, 236 can be interrupted by the bottom retention features 211, and the fold lines 40, 41, 44, 46 of the first embodiment can be omitted so that the bottom bevel panels 38, 42 of the first embodiment are not included in the blank 203. The side panels 222, 230 of the second embodiment can include cutouts 215 at each end for at least partially

accommodating the shape of the containers C. Alternatively, the edges of the side panels 222, 230 could have a different shape to correspond to a different container shape or to reflect a particular logo, or the edges could be straight. The blank 203 could be otherwise shaped, arranged, and/or configured without departing from the disclosure.

[0035] Fig. 8 is a plan view of an exterior surface 402 of a blank 403 for forming a carrier (not shown) according to a third embodiment of the disclosure. The third embodiment is generally similar to the second embodiment, except for variations noted and variations that will be apparent to one of ordinary skill in the art. Accordingly, similar or identical features of the embodiments have been given like or similar reference numbers. As shown in Fig. 8, the blank 403 has different locking features for interlocking the bottom panels 426, 434. The second bottom panel 434 can include three secondary locking tabs 458 that are generally aligned with the respective primary locking tabs 454. The first bottom panel 426 can include an inner primary female locking edge 452a and an inner slit 456a for receiving the respective inner primary male locking tab 454 and inner secondary male locking tab 458. Additionally, the first bottom panel 426 can include outer primary female locking edges 452b and outer secondary female locking edges 456b adjacent a respective opening 455. An outer retention tab 457 can be foldably connected to the first bottom panel 426 along a respective longitudinal fold line 459 and can include respective curved folds 461. Accordingly, when the outer primary male locking tabs 454 engage the respective outer primary female locking edges 452b and the outer secondary male locking tabs 458 engage the respective outer secondary female locking edges 456b, the respective outer retention tabs 457 are folded inwardly into the interior of the carrier (not shown) to engage and/or to help retain a respectively adjacent container C. Any of the locking features of the bottom panels 426, 434 could be omitted or could be otherwise shaped, arranged, positioned, and/or configured without departing from the disclosure. Additionally, the blank 403 could be otherwise shaped, arranged, and/or configured without departing from the disclosure.

[0036] Fig. 9 is a plan view of an exterior surface 602 of a blank 603 for forming a carrier (not shown) according to a fourth embodiment of the disclosure. The fourth embodiment is generally similar to the third embodiment, except for variations noted and variations that will be apparent to one of ordinary skill in the art. Accordingly, similar or identical features of the embodiments have been given like or similar reference numbers. As shown in Fig. 9, the blank 603 includes side panels 22, 30 with generally straight free edges similar or identical to the first embodiment (Fig. 1), retention features 211 in the first side panel 22 and the first bottom panel 426 that are similar to the second embodiment (Fig. 7), and locking features for interlocking the bottom

panels 426, 434 similar or identical to the third embodiment (Fig. 8). Additionally, the blank 603 can include bottom retention features 611 in the second side panel 30 and the second bottom panel 434. The bottom retention features 611 can include retention tabs 264 similar to those in the second embodiment (Fig. 7) and corner retainers 74 similar to those in the first embodiment (Figs. 1 and 2). As shown in Fig. 9, the retention flaps 264 of the retention features 211, 611 are generally the same as the retention flaps 264 of the blanks 203, 403 of the second and third embodiments except that the retention flaps in the blank 603 are relatively smaller than the retention flaps 264 of the blanks 203, 403. The blank 603 could be otherwise shaped, arranged, and/or configured without departing from the disclosure.

[0037] Any of the features of the various embodiments of the disclosure can be combined with, replaced by, or otherwise configured with other features of other embodiments of the disclosure without departing from the scope of this disclosure. Further, it is noted that the retention features and/or the container configurations of the various embodiments can be incorporated into a carton or carrier having any carton style or panel configuration. The carrier styles and panel configurations described above are included by way of example. Additionally, the shapes of the retention features can be substantially any shape. The shapes described above and included in the figures are included by way of example.

[0038] In general, the blanks according to the present disclosure can be constructed from paperboard having a caliper so that it is heavier and more rigid than ordinary paper. The blanks can also be constructed of other materials, such as cardboard, or any other material having properties suitable for enabling the carton to function at least generally as described above. The blanks can be coated with, for example, a clay coating. The clay coating may then be printed over with product, advertising, and other information or images. The blanks may then be coated with a varnish to protect information printed on the blanks. The blanks may also be coated with, for example, a moisture barrier layer, on either or both sides of the blanks. The blanks can also be laminated to or coated with one or more sheet-like materials at selected panels or panel sections.

[0039] In accordance with the exemplary embodiments, a fold line can be any substantially linear, although not necessarily straight, form of weakening that facilitates folding therealong. More specifically, but not for the purpose of narrowing the scope of the present disclosure, fold lines include: a score line, such as lines formed with a blunt scoring knife, or the like, which creates a crushed or depressed portion in the material along the desired line of weakness; a cut

that extends partially into a material along the desired line of weakness, and/or a series of cuts that extend partially into and/or completely through the material along the desired line of weakness; and various combinations of these features. In situations where cutting is used to create a fold line, typically the cutting will not be overly extensive in a manner that might cause a reasonable user to incorrectly consider the fold line to be a tear line.

[0040] The above embodiments may be described as having one or more panels adhered together by glue during erection of the carton embodiments. The term “glue” is intended to encompass all manner of adhesives commonly used to secure carton panels in place.

[0041] The foregoing description of the disclosure illustrates and describes various exemplary embodiments. Various additions, modifications, changes, etc., could be made to the exemplary embodiments without departing from the spirit and scope of the disclosure. It is intended that all matter contained in the above description or shown in the accompanying drawings shall be interpreted as illustrative and not in a limiting sense. Additionally, the disclosure shows and describes only selected embodiments of the disclosure, but the disclosure is capable of use in various other combinations, modifications, and environments and is capable of changes or modifications within the scope of the inventive concept as expressed herein, commensurate with the above teachings, and/or within the skill or knowledge of the relevant art. Furthermore, certain features and characteristics of each embodiment may be selectively interchanged and applied to other illustrated and non-illustrated embodiments of the disclosure.

THE EMBODIMENTS OF THE INVENTION IN WHICH AN EXCLUSIVE PROPERTY OR PRIVILEGE IS CLAIMED ARE DEFINED AS FOLLOWS:

1. A carrier for at least partially holding a plurality of articles, the carrier comprising a plurality of panels that extends at least partially around an interior of the carrier, the plurality of panels comprising at least a top panel, a side panel, and a bottom panel;

a plurality of article receiver features disposed in at least the top panel in at least a first row and a second row, the first row comprising at least one more article receiver feature than the second row, each article receiver feature of the plurality of article receiver features being for at least partially receiving a respective article of the plurality of articles, wherein the first row is disposed adjacent the side panel and the second row is spaced apart from the side panel by the first row, a first end article receiver feature in the first row of the plurality of article receiver features is for receiving a first end article of the plurality of articles, and a second end article receiver feature in the second row of the plurality of article receiver features is for receiving a second end article of the plurality of articles, at least the first end article for being disposed adjacent an end of the carrier; and

a retention feature extending in at least one of the side panel and the bottom panel, the retention feature being for at least partially retaining at least one article that is at least partially received in a respective one of the article receiving features in the first row, wherein the retention feature comprises a corner retainer foldably connected to at least one of the side panel and the bottom panel, the corner retainer is for at least partially retaining the first end article at the end of the carrier, and the first end article is for engaging the second end article for at least partially retaining the second end article at the end of the carrier.

2. The carrier of claim 1, wherein the article receiver features of the plurality of article receiver features are arranged in the first row, the second row, and a third row, the third row comprising at least one more article receiver feature than the second row.

3. The carrier of claim 2, wherein the side panel is a first side panel, the plurality of panels further comprises a second side panel disposed opposite to the first side panel, the third row is disposed adjacent the second side panel, and the second row is spaced from the second side panel by the third row.

4. The carrier of claim 2, wherein:

the side panel is a first side panel, the bottom panel is a first bottom panel, the retention feature is a first retention feature;

the plurality of panels further comprises a second side panel and a second bottom panel, and a second retention feature extends in at least one of the second side panel and the second bottom panel; and

the second retention feature is for at least partially retaining at least one article that is at least partially received in a respective one of the article receiving features in the third row.

5. The carrier of claim 2, wherein the article receiver features of the second row are staggered with respect to the article receiver features of the first row and the third row.

6. The carrier of claim 5, wherein the article receiver features of the second row are offset from the article receiver features of the first row and the third row so that a respective center of each article receiver feature of the second row is disposed generally halfway between two of the article receiver features in the first row and between two of the article receiver features of the third row.

7. The carrier of claim 1, wherein the article receiver features of the second row are staggered with respect to the article receiver features of the first row.

8. The carrier of claim 7, wherein the article receiver features of the second row are offset from the article receiver features of the first row so that a respective center of each article receiver feature of the second row is disposed generally halfway between two adjacent article receiver features in the first row.

9. The carrier of claim 1, wherein the corner retainer comprises a retention panel foldably connected to at least one of the side panel and the bottom panel, a first gusset panel foldably connected to the retention panel, and a second gusset panel foldably connected to the first gusset panel and the bottom panel, the retention panel extending at least partially over the end of the carrier for engaging the first end article.

10. The carrier of claim 9, wherein the first gusset panel and the second gusset panel are at least partially in face-to-face contact with one another and are for being at least partially disposed between the bottom panel and the first end article of the plurality of articles.

11. The carrier of claim 1, wherein the retention feature comprises two retention tabs foldably connected to at least one of the side panel and the bottom panel adjacent a corner opening.

12. A blank for forming a carrier for holding a plurality of articles, the blank comprising:  
a plurality of panels comprising at least a top panel, a side panel, and a bottom panel;  
a plurality of article receiver features disposed in at least the top panel in at least a first row and a second row, the first row comprising at least one more article receiver feature than the second row, each article receiver feature of the plurality of article receiver features being for at least partially receiving a respective article of the plurality of articles when the carrier is formed from the blank, wherein the first row is disposed adjacent the side panel and the second row is spaced apart from the side panel by the first row, a first end article receiver feature in the first row of the plurality of article receiver features is for receiving a first end article of the plurality of articles when the carrier is formed from the blank, and a second end article receiver feature in the second row of the plurality of article receiver features is for receiving a second end article of the plurality of articles when the carrier is formed from the blank, at least the first end article for being disposed adjacent an end of the carrier formed from the blank; and

a retention feature extending in at least one of the side panel and the bottom panel, the retention feature being for at least partially retaining at least one article that is at least partially received in a respective one of the article receiving features in the first row when the carrier is formed from the blank, wherein the retention feature comprises a corner retainer foldably connected to at least one of the side panel and the bottom panel, the corner retainer is for at least partially retaining the first end article at the end of the carrier formed from the blank, and the first end article is for engaging the second end article for at least partially retaining the second end article at the end of the carrier formed from the blank.

13. The blank of claim 12, wherein the article receiver features of the plurality of article receiver features are arranged in the first row, the second row, and a third row, the third row comprising at least one more article receiver feature than the second row.

14. The blank of claim 13, wherein the side panel is a first side panel, the plurality of panels further comprises a second side panel disposed on an opposite side of the top panel from the first side panel, the third row is disposed adjacent the second side panel, and the second row is spaced from the second side panel by the third row.

15. The blank of claim 13, wherein:

the side panel is a first side panel, the bottom panel is a first bottom panel, the retention feature is a first retention feature;

the plurality of panels further comprises a second side panel and a second bottom panel, and a second retention feature extends in at least one of the second side panel and the second bottom panel; and

the second retention feature is for at least partially retaining at least one article that is at least partially received in a respective one of the article receiving features in the third row when the carrier is formed from the blank.

16. The blank of claim 13, wherein the article receiver features of the second row are staggered with respect to the article receiver features of the first row and the third row.

17. The blank of claim 16, wherein the article receiver features of the second row are offset from the article receiver features of the first row and the third row so that a respective center of each article receiver feature of the second row is disposed generally halfway between two of the article receiver features in the first row and between two of the article receiver features of the third row.

18. The blank of claim 12, wherein the article receiver features of the second row are staggered with respect to the article receiver features of the first row.

19. The blank of claim 18, wherein the article receiver features of the second row are offset from the article receiver features of the first row so that a respective center of each article receiver feature of the second row is disposed generally halfway between two adjacent article receiver features in the first row.

20. The blank of claim 12, wherein the corner retainer comprises a retention panel foldably connected to at least one of the side panel and the bottom panel, a first gusset panel foldably connected to the retention panel, and a second gusset panel foldably connected to the first gusset panel and the bottom panel.

21. The blank of claim 12, wherein the retention feature comprises two retention tabs foldably connected to at least one of the side panel and the bottom panel adjacent a corner opening.

22. A package comprising:

a carrier having a first substantially open end and a second substantially open end, the carrier comprising a plurality of panels that extends at least partially around an interior of the carrier, the plurality of panels comprising at least a top panel, a bottom panel, and a side panel, wherein the carrier

further comprises a plurality of article receiver features disposed in at least the top panel and a corner retainer foldably connected to at least one of the side panel and the bottom panel;

a plurality of articles at least partially disposed in the interior of the carrier, the articles of the plurality of articles being arranged in at least a first row and a second row, the first row comprising at least one more article than the second row, wherein the first row is disposed adjacent the side panel and the second row is spaced apart from the side panel by the first row, a first end article of the first row is disposed adjacent the first substantially open end of the carrier, the corner retainer at least partially retains the first end article at the first substantially open end of the carrier, and the first end article engages a second end article of the second row to at least partially retain the second end article at the first substantially open end of the carrier;

wherein each article receiver feature of the plurality of article receiver features at least partially receives a respective article of the plurality of articles.

23. The package of claim 22, wherein the articles in the second row are nested with the articles in the first row.

24. The package of claim 22, wherein the articles of the plurality of articles are arranged in the first row, the second row, and a third row, the third row comprises at least one more article than the second row, and the articles in the second row are nested with the articles in the first row and with the articles in the third row.

25. The package of claim 22, wherein:

the side panel is a first side panel, the plurality of panels further comprises a second side panel disposed opposite to the first side panel;

the articles of the plurality of articles are arranged in the first row, the second row, and a third row, the third row comprising at least one more article than the second row; and

the third row is disposed adjacent the second side panel, and the second row is spaced from the second side panel by the third row.

26. The package of claim 25, wherein:

the bottom panel is a first bottom panel foldably connected to the first side panel, the plurality of panels further comprises a second bottom panel foldably connected to the second side panel; and

the carrier further comprises a first retention feature extending in at least one of the first side panel and the first bottom panel, and a second retention feature extending in at least one of the second side panel and the second bottom panel, the first retention feature at least partially retaining at least one

article in the first row and the second retention feature at least partially retaining at least one article in the third row.

27. The package of claim 22, wherein the bottom panel is foldably connected to the side panel, and the carrier further comprises a retention feature extending in at least one of the side panel and the bottom panel, the retention feature at least partially retaining at least one article in the first row.

28. The package of claim 22, wherein the corner retainer comprises a retention panel foldably connected to at least one of the side panel and the bottom panel, a first gusset panel foldably connected to the retention panel, and a second gusset panel foldably connected to the first gusset panel and to the bottom panel, the retention panel extending at least partially over the first substantially open end of the carrier.

29. The package of claim 28, wherein the first gusset panel and the second gusset panel are at least partially in face-to-face contact with one another and are at least partially disposed between the bottom panel and the first end article of the plurality of articles.

30. The package of claim 27, wherein the retention feature comprises two retention tabs foldably connected to at least one of the side panel and the bottom panel adjacent a corner opening.

31. The package of claim 22, wherein:  
the plurality of articles comprises three articles in the first row; and  
the carrier further comprises three retention features extending in at least one of the side panel and the bottom panel, each of the three retention features at least partially retaining a respective one of the three articles in the first row.

32. A method of forming a package comprising:  
obtaining a plurality of articles and a blank comprising a plurality of panels, the plurality of panels comprising at least a top panel, a bottom panel, and a side panel, and the blank further comprises a plurality of article receiver features disposed in at least the top panel and a corner retainer foldably connected to at least one of the side panel and the bottom panel;

arranging the articles of the plurality of articles in at least a first row and a second row, the first row comprising at least one more article than the second row, the first row comprising a first end article and the second row comprising a second end article;

forming a carrier from the blank by positioning the top panel relative to the articles of the plurality of articles so that each article receiver feature of the plurality of article receiver features at

least partially receives a top portion of a respective article of the plurality of articles and wrapping the plurality of panels at least partially around the plurality of articles, the carrier having a first substantially open end and a second substantially open end and the first end article of the first row being disposed adjacent the first substantially open end, wherein the wrapping the plurality of panels comprises folding the side panel to be positioned adjacent the first row of the plurality of articles, the second row of the plurality of articles being spaced from the side panel by the first row; and

positioning the corner retainer to at least partially retain the first end article at the first substantially open end of the carrier, the first end article engaging the second end article of the second row to at least partially retain the second end article at the first substantially open end of the carrier.

33. The method of claim 32, wherein the arranging the articles further comprises positioning the articles in the second row to be nested with the articles in the first row.

34. The method of claim 32, wherein the arranging the articles further comprises arranging the articles in a third row and positioning the articles in the second row to be nested with the articles in the first row and the third row.

35. The method of claim 32, wherein the carrier further comprises a retention feature extending in at least one of the side panel and the bottom panel, and the forming the carrier further comprising positioning the side panel and the bottom panel so that the retention feature at least partially retains at least one article in the first row.

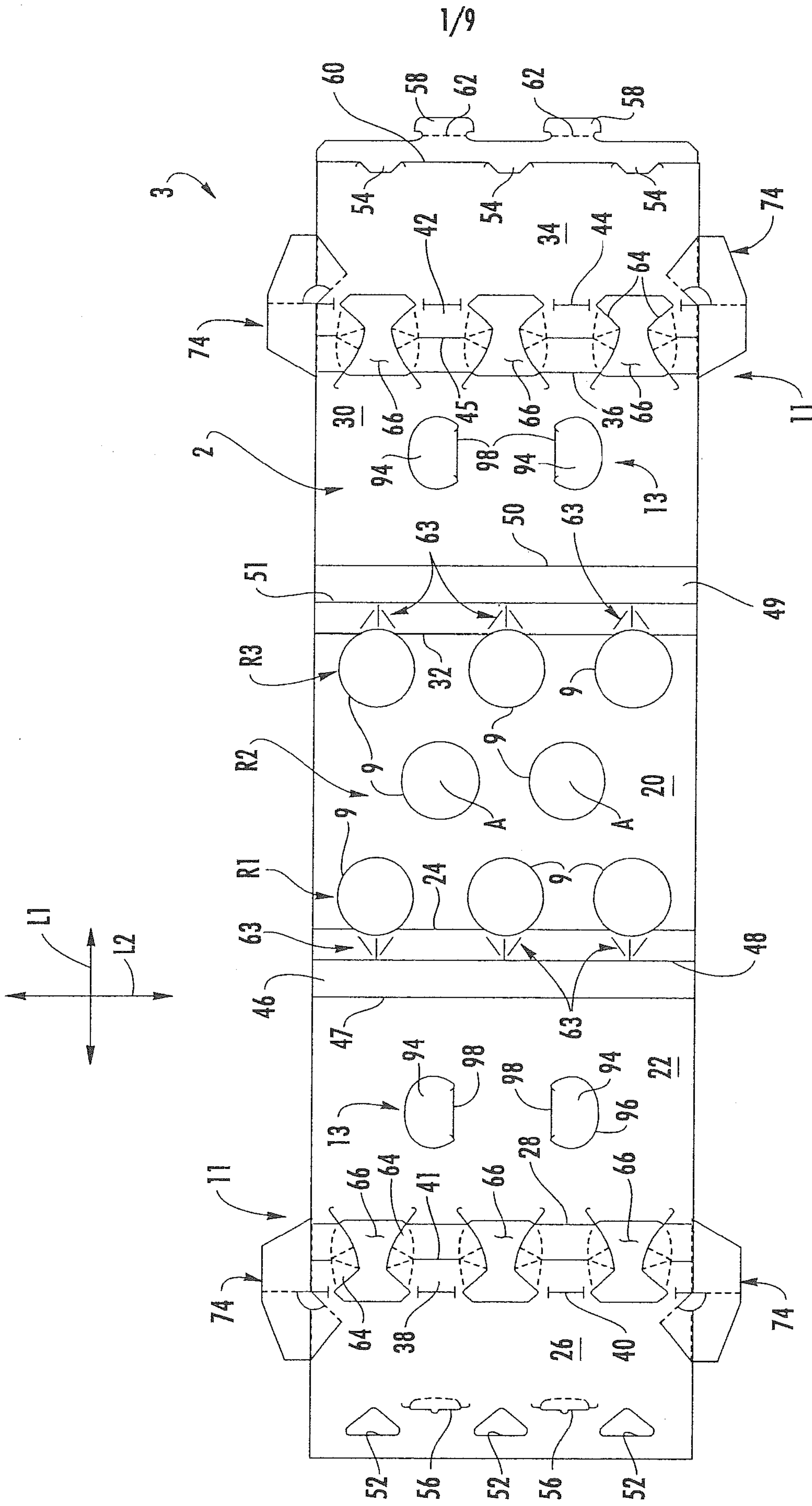

FIG. 1

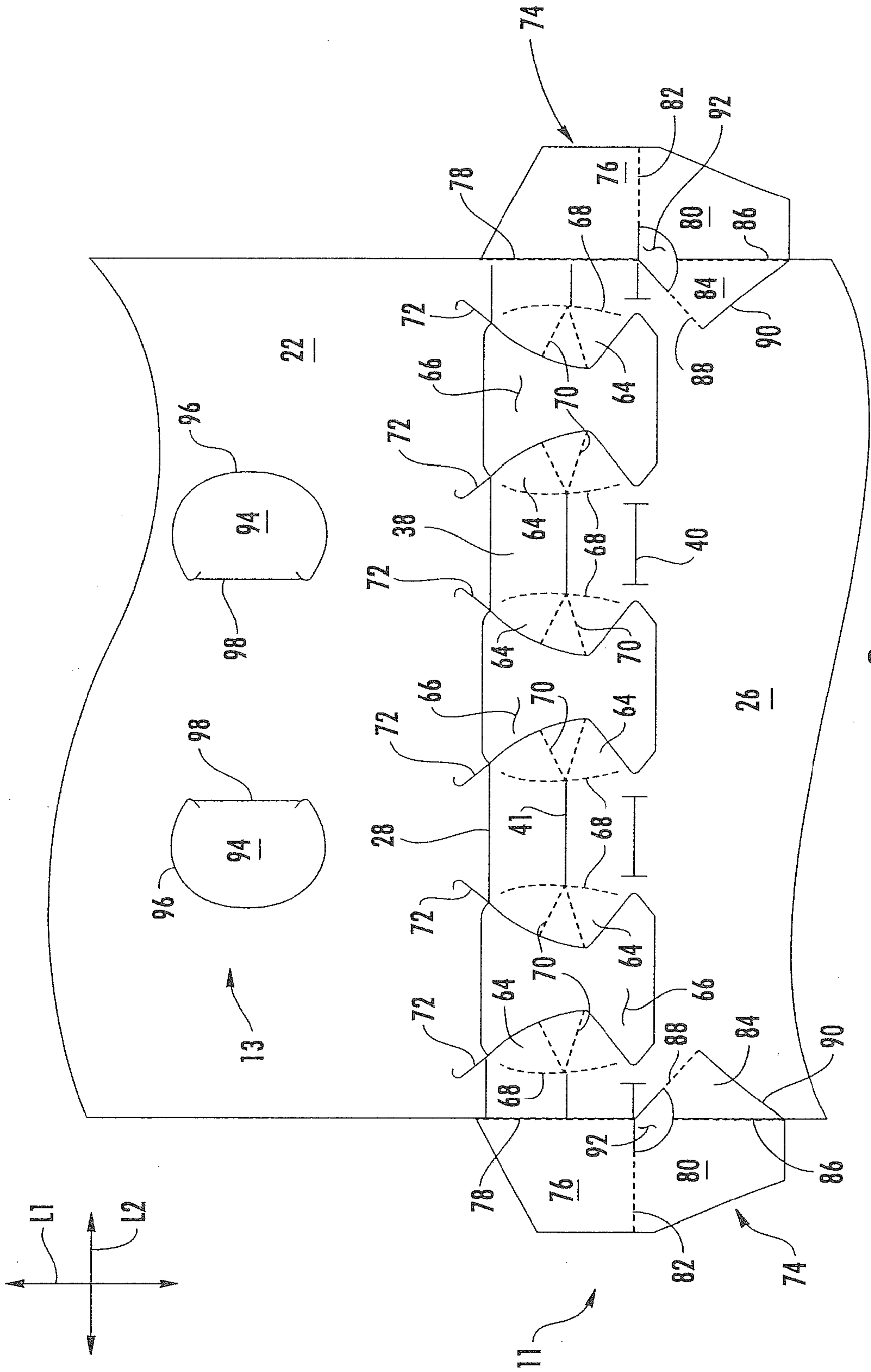

FIG. 2

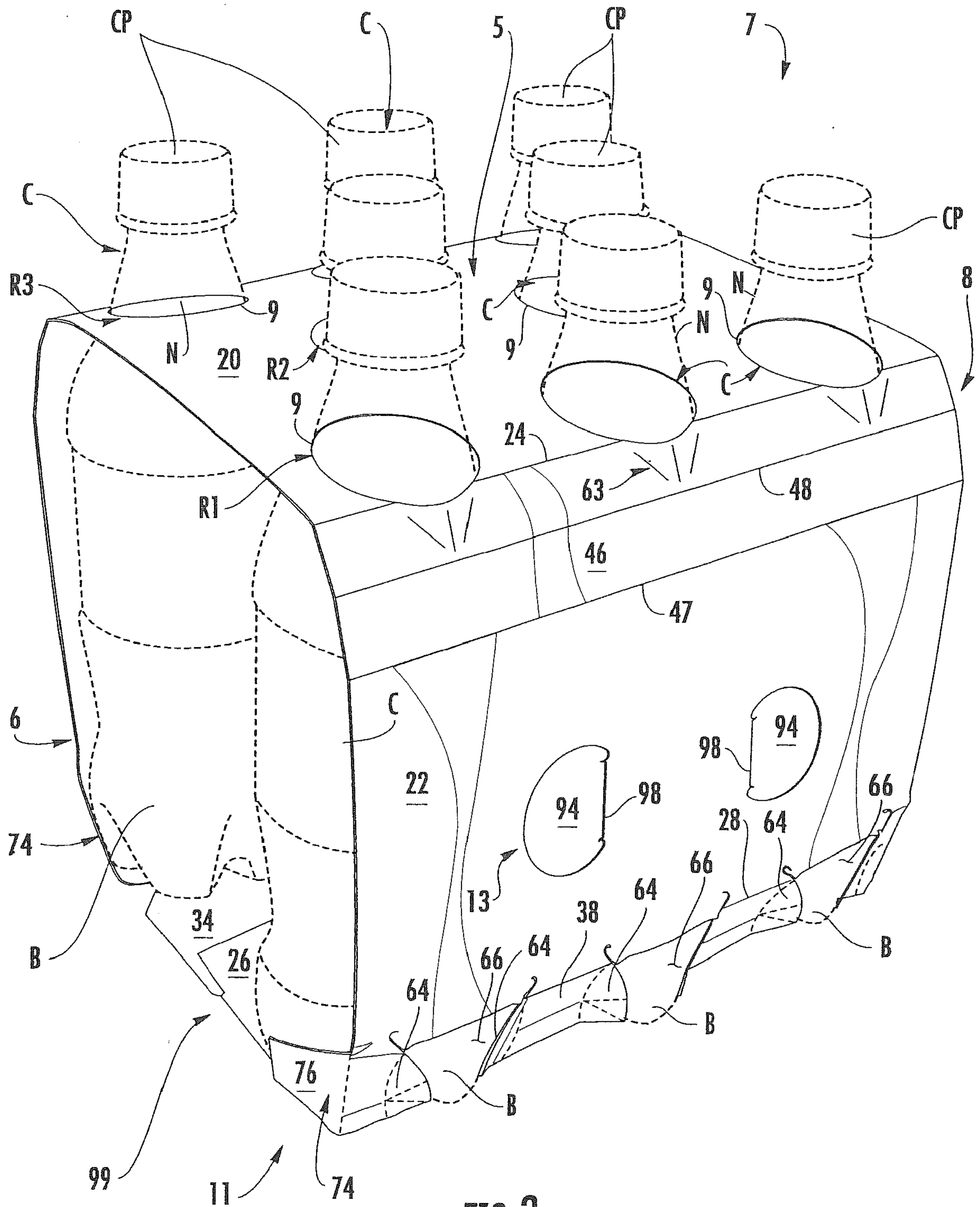

FIG. 3

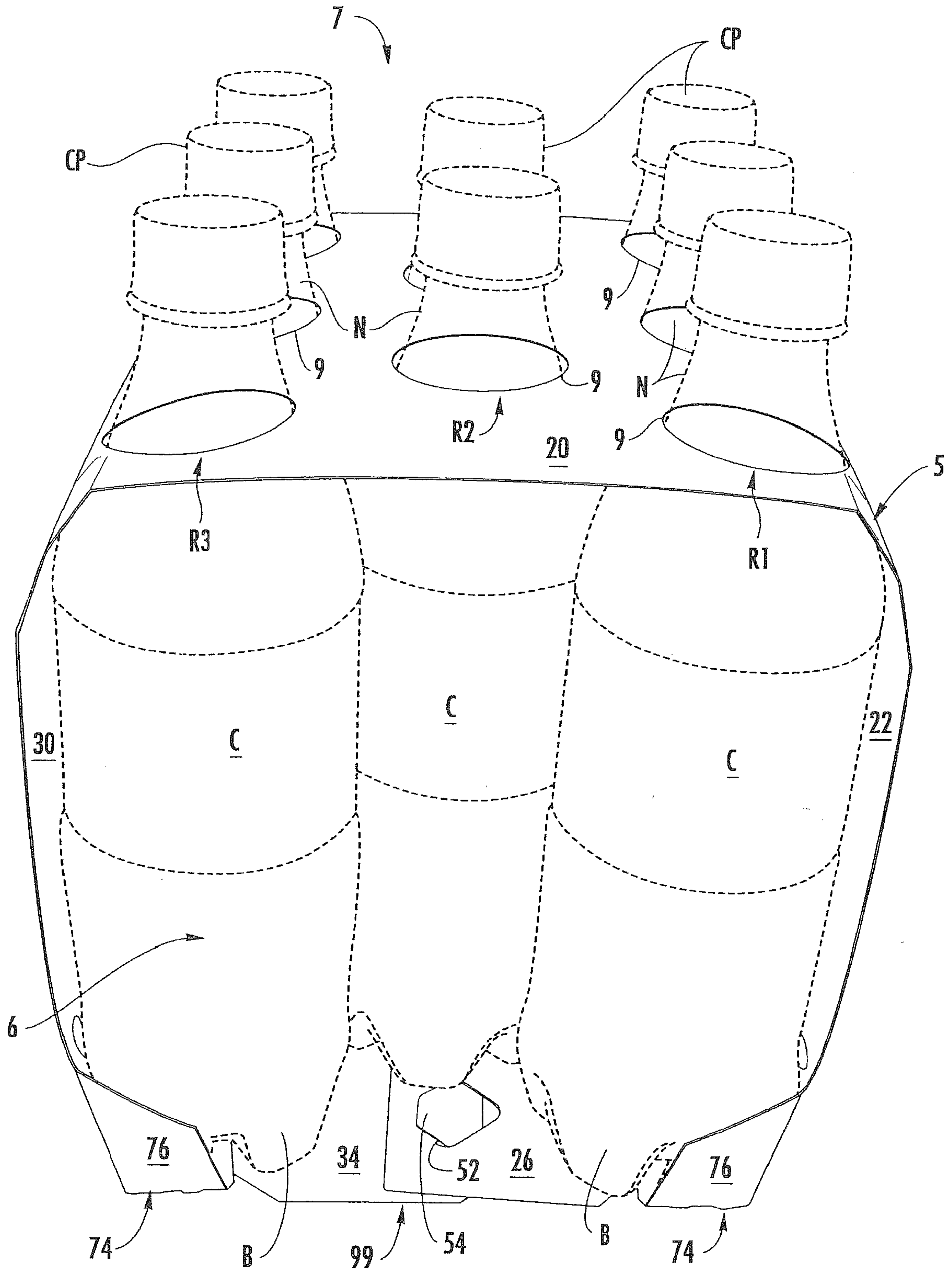

FIG. 4

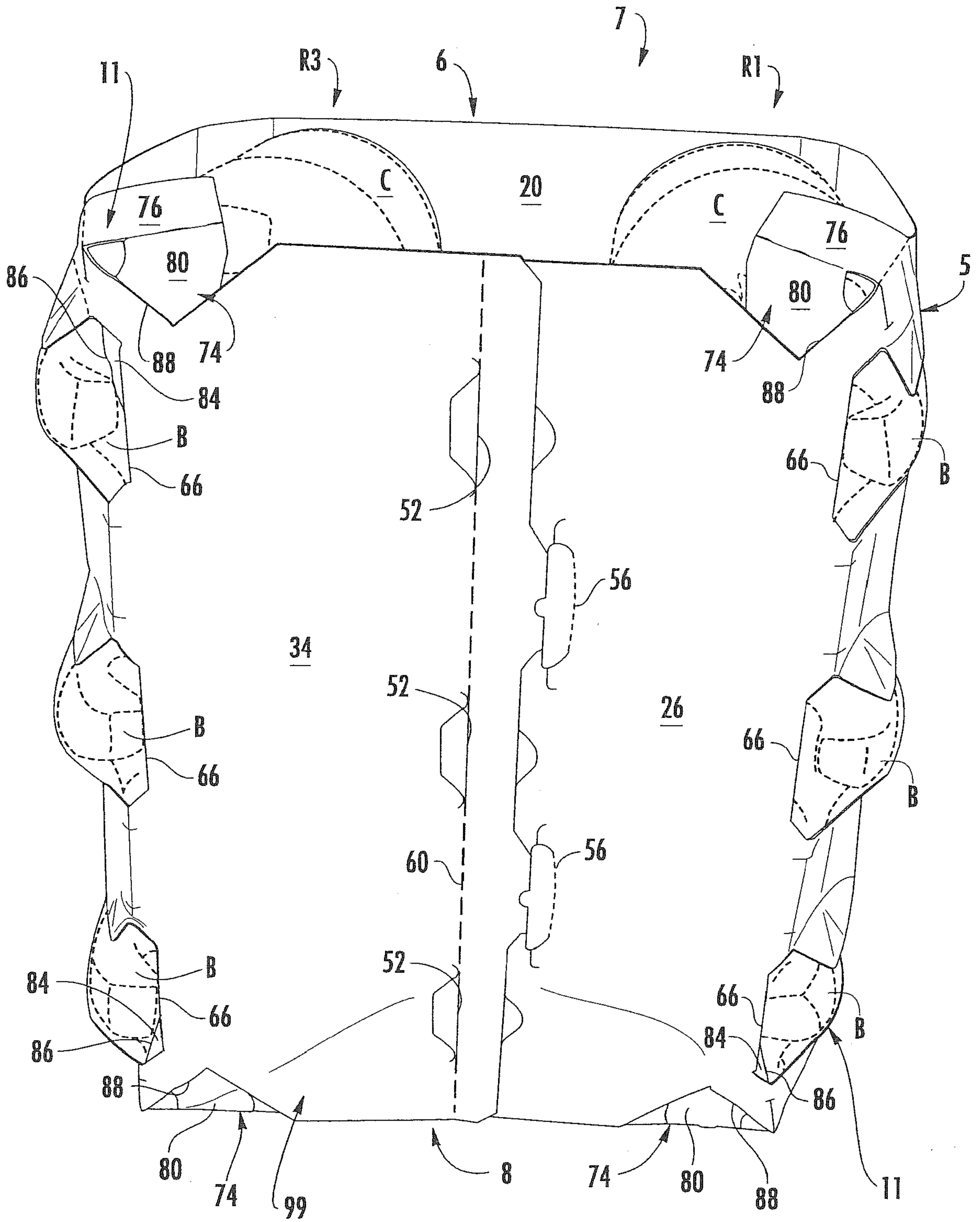

FIG. 5





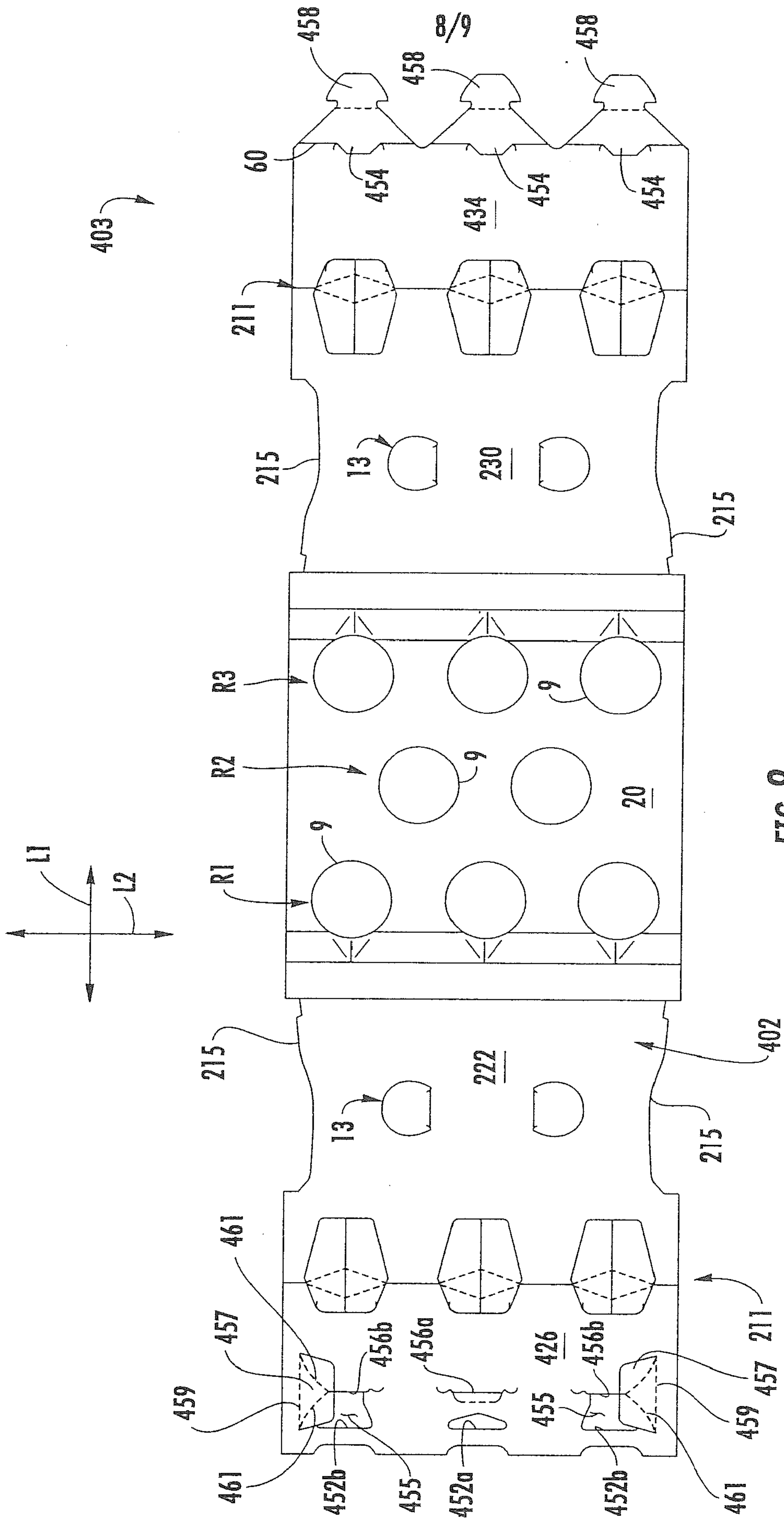

FIG. 8



