

C. F. JENKINS.
TWO-CYCLE GAS ENGINE.
APPLICATION FILED NOV. 18, 1910.

997,195.

Patented July 4, 1911.

2 SHEETS—SHEET 1.

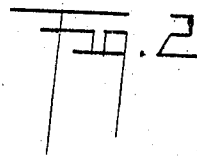
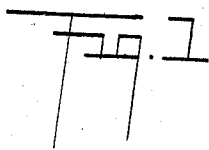
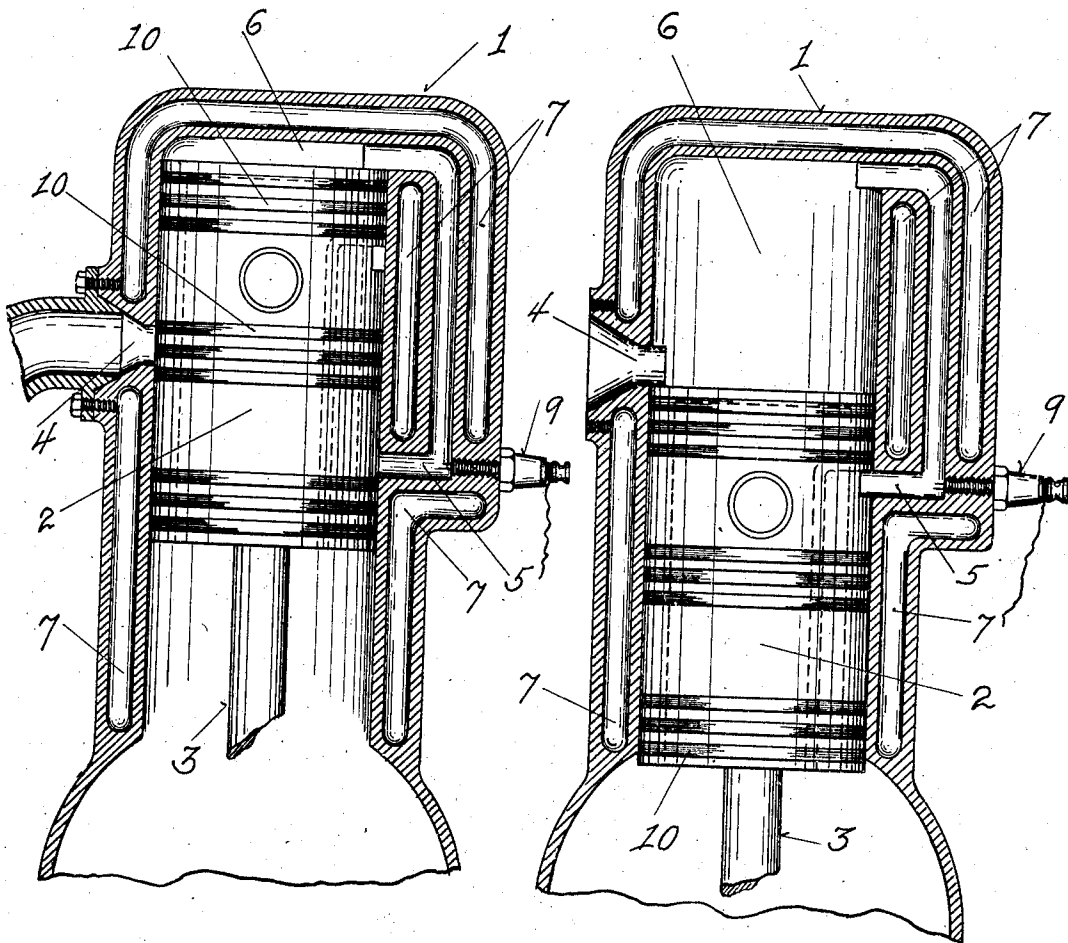

WITNESSES:

C. F. Jenkins
E. L. Lee

INVENTOR.

C. Francis Jenkins

C. F. JENKINS.
TWO-CYCLE GAS ENGINE.
APPLICATION FILED NOV. 18, 1910

997,195.

Patented July 4, 1911.
2 SHEETS—SHEET 2.

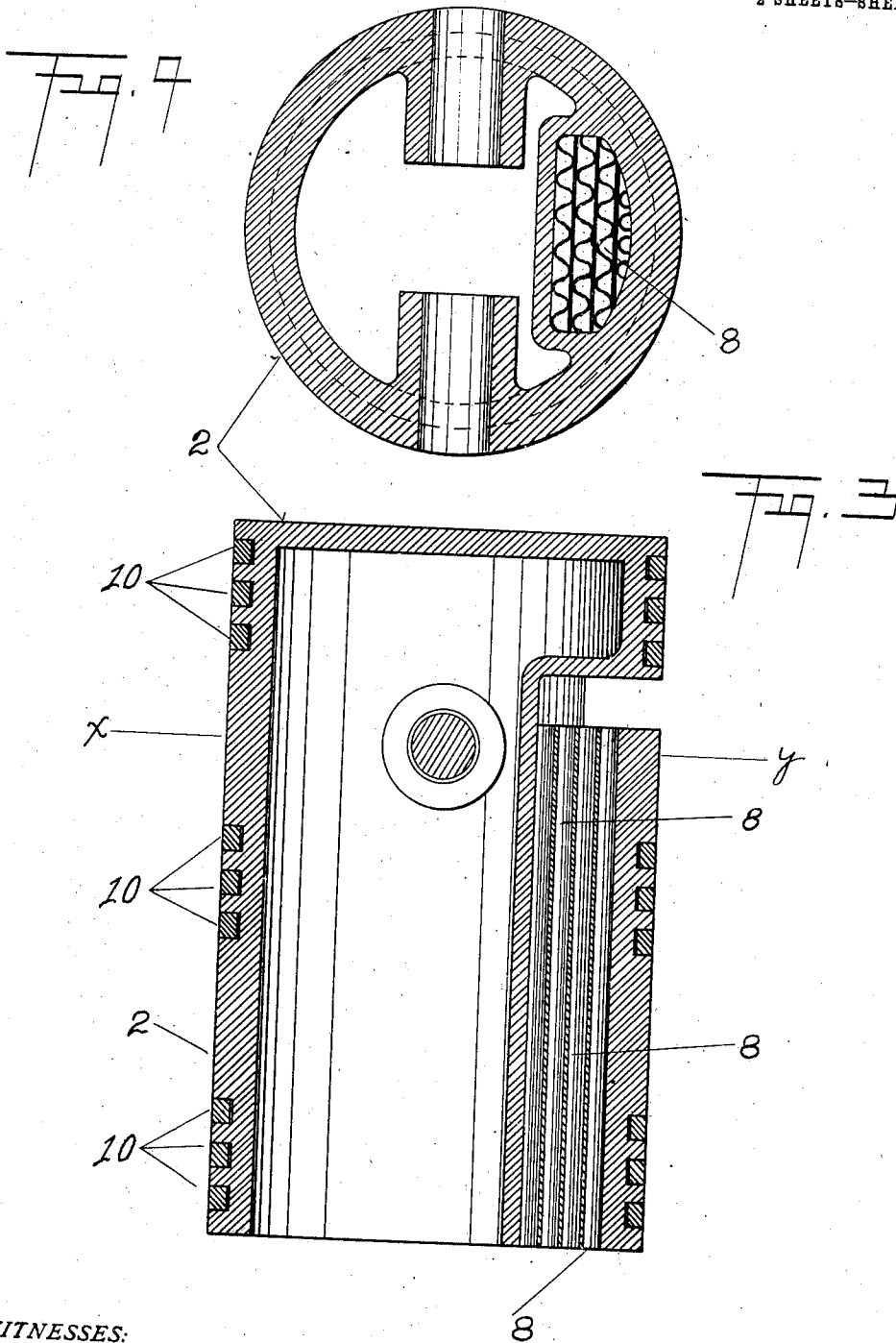

WITNESSES:

A. W. Jenkins
G. Love

8
INVENTOR.
C. Francis Jenkins

UNITED STATES PATENT OFFICE.

CHARLES FRANCIS JENKINS, OF WASHINGTON, DISTRICT OF COLUMBIA.

TWO-CYCLE GAS-ENGINE.

997,195.

Specification of Letters Patent.

Patented July 4, 1911.

Application filed November 18, 1910. Serial No. 593,028.

To all whom it may concern:

Be it known that I, CHARLES FRANCIS JENKINS, citizen of the United States, residing at Washington, District of Columbia, have invented certain new and useful Improvements in Two-Cycle Gas-Engines, of which the following is a specification.

This invention relates to that class of gas engines known as "two-cycle" engines.

It has for its object an engine which can be throttled down until it turns over slowly and explodes evenly under light load and when running idle. This is accomplished by placing the sparking device at the point where the gas enters the combustion space.

The two-cycle motor is notoriously wasteful of gasolene in automobile use on the average road surface. This comes about not because the motor is not as efficient at hard work as the four-cycle motor, but principally because, unless the motor is working at near its maximum capacity, there is too large a proportion of the carbureted charge mixed with the burned gas of the previous explosion. Fully nine-tenths of all automobile work is done at a rate much below fifty per cent. of the maximum power of the motor, that is, the motor is working under throttled charge the greater portion of the time. This means that much of the good gas is so mixed with the bad gas at the point of highest compression that considerable of the gasolene vapor is never burned at all. Beside the waste of gasolene, it is noticeable in the bad-smelling exhaust. In many comparisons of the two-cycle with four-cycle motors under like conditions this loss has been found to average about ten to twenty in favor of the four-cycle, that is, the four cycle motor will work a given weight of car twenty miles per gallon of gasolene, while the two-cycle motor under the same conditions will only make ten miles to the gallon. This is accounted for in several minor ways, but the principal advantage the four-cycle motor has over the two-cycle is in the fact that the spark-plug is located at the gas inlet and in such manner that it fires small charges as efficiently as large charges, or practically so. This is not true in the usual construction of the two-cycle motor for the reason that the spark plug is located at a point the farthest removed from the gas inlet. If, however, the spark plug could be as advantageously located in a two-cycle

motor as in the construction shown by the best practice in four-cycle motors there should be a corresponding efficiency. This efficiency would come about also because the spark could be advanced to its most advantageous position while the charge could be reduced to the least possible amount necessary to keep the motor turning. Obviously less heat would be wasted in the cooling jacket especially when running idle. No two-cycle engine, as at present constructed, will run idle without missing, while the four-cycle motor has been so developed and perfected that it not only runs idle without missing, but so slowly and quietly as to be practically noiseless. The trouble is that the small charges in the two-cycle engine will not fire because they are so mixed with the bad gas of the previous explosion. Necessarily the charge must be increased until there is a preponderance of good gas and the speed of the car controlled to such an extent as is possible by retarding the spark. As is well known to gasolene motor engineers, economy and efficiency is obtained by an advanced spark and a throttled charge. This has, to the present time, in two-cycle motors, been an impossibility, principally because as stated above the spark plug is placed at the most remote position, instead of being placed so that it sparks in a charge of good gas no matter how small the charge. If the firing begins in good gas then practically all the gas is converted into power, while, if the spark occurs in a poor mixture, the mixture is fired with difficulty and often not at all until enriched by the second charge. The result is erratic running and uneven firing, that is, running light the motor "stutters."

The present construction incorporates the desirable features of a four-cycle motor, that is, economy of gas with silent running and even explosions while running idle or at light work, while at the same time retaining all the features of simplicity of construction, easy cooling, etc., of the ordinary two-cycle motor. Heretofore when this desirable end was sought to be accomplished, baffle-plates, pockets, or other confining and irregular shapes were employed on the top of the piston (usually), and these, getting red hot by the enveloping flame of the explosion, ignited the gas as it entered, and before the spark plug got a chance to fire the charge,

thus creating back-pressure, loss of power, an excessively hot engine, etc., defeating the very end sought.

In the construction shown in the present invention the spark plug is placed at the point of ingress of the gas, and in a confined passage, and overheating prevented by having this narrow passage water-jacketed.

In the drawings, Figure 1 is a sectional view of an engine cylinder constructed in accordance with this invention, and having a piston therein at the top of the piston stroke; Fig. 2 is a similar sectional view with the piston at the bottom of its stroke; Fig. 3 is a vertical sectional view of the piston; and Fig. 4 a cross section view of the piston, on line *x-y*.

In all the figures like symbols refer to like parts, in which—

1 is a cylinder of the engine; 2 a piston therein; 3 a connecting rod; 4 an exhaust port; 5 a combustion passage in communication with the combustion space 6 above the piston; 7 the water-jacket spaces; 8 a tubular passage in the piston which, when the piston is down, puts the crank-case in communication with the combustion passage; 9 a spark-plug, or other suitable device for firing the charge; and 10 piston rings of which nine are shown.

The operation of the engine, obvious to those skilled in the art, is as follows: Carbureted gas is drawn into the crank-case from the carbureter (not shown) in the usual manner, *i. e.*, by the upward movement of the piston; and by its downward movement is forced through the tubular passage 8 into the combustion passage 5, driving ahead of it the bad gas remaining after the previous explosion. If the throttle is wide open the combustion space 6 above the piston will be completely filled, and on the ignition of the charge the maximum pressure will be exerted on the piston. If, however, the throttle is but slightly open the combustion passage only may be filled and none overflow into the combustion space above the piston. This small charge will be just as efficient in proportion to its volume as was the larger charge for it was compressed to practically the same extent and none was mixed with the bad gas of the previous explosion. It will, therefore, be obvious that the spark-plug is always swept by the fresh charge, be it large or small, and the ignition will be just as certain in one case as in the other, although the charge and consequent impulse may be only just sufficient to keep the engine turning over, and without missing a single explosion.

The purpose of the multi-tubular passage

8, as explained in Patent No. 972,379, is to prevent back-firing. And this device, whether multi-tubular or gauze, is usually termed a "screen," and in the claims this is what is meant.

What I claim is—

1. In a gas engine, a cylinder, a piston reciprocating therein, a longitudinal passage located outside of the cylinder but within the water-jacket space of said cylinder, the upper end of the passage being in open communication with the upper end of said cylinder, the lower end adapted to be opened and closed by the reciprocation of the piston, and a spark-plug located at the lower or ingress end of the passage.

2. In a gas engine, a cylinder, a piston reciprocating therein, a longitudinal passage located outside of the cylinder but within the water-jacket space of said cylinder, the upper end of the passage being in open communication with the upper end of said cylinder, the lower end adapted to be opened and closed by the reciprocation of the piston, a spark-plug located at the lower or ingress end of the passage, said piston having a plurality of rings so located thereon as to lie on each side of the ingress end of the passage when the piston is at the upper end of its stroke.

3. In a gas engine, a cylinder, a piston reciprocating therein, a longitudinal passage located outside of the cylinder but within the water-jacket space of said cylinder, the upper end of the passage being in open communication with the upper end of said cylinder, the lower end adapted to be opened and closed by the reciprocation of the piston, said piston having a plurality of rings thereon so located as to lie on each side of the ingress end of the passage when the piston is at the upper end of its stroke.

4. In a gas engine, a cylinder, a piston reciprocating therein, a longitudinal passage located outside of the cylinder but within the water-jacket space of said cylinder, the upper end of the passage being in open communication with the upper end of said cylinder, the lower end adapted to be opened and closed by the reciprocation of the piston, said piston having a screened by-pass therein communicating with the said passage when the piston is at the lower end of its stroke.

In testimony whereof I have affixed my signature in presence of two witnesses.

CHARLES FRANCIS JENKINS.

Witnesses:

G. LOVE,
JAMES L. CRAWFORD.