

(No Model.)

2 Sheets—Sheet 1.

F. LEY.

SAND MOLDING MACHINE.

No. 257,030.

Patented Apr. 25, 1882.

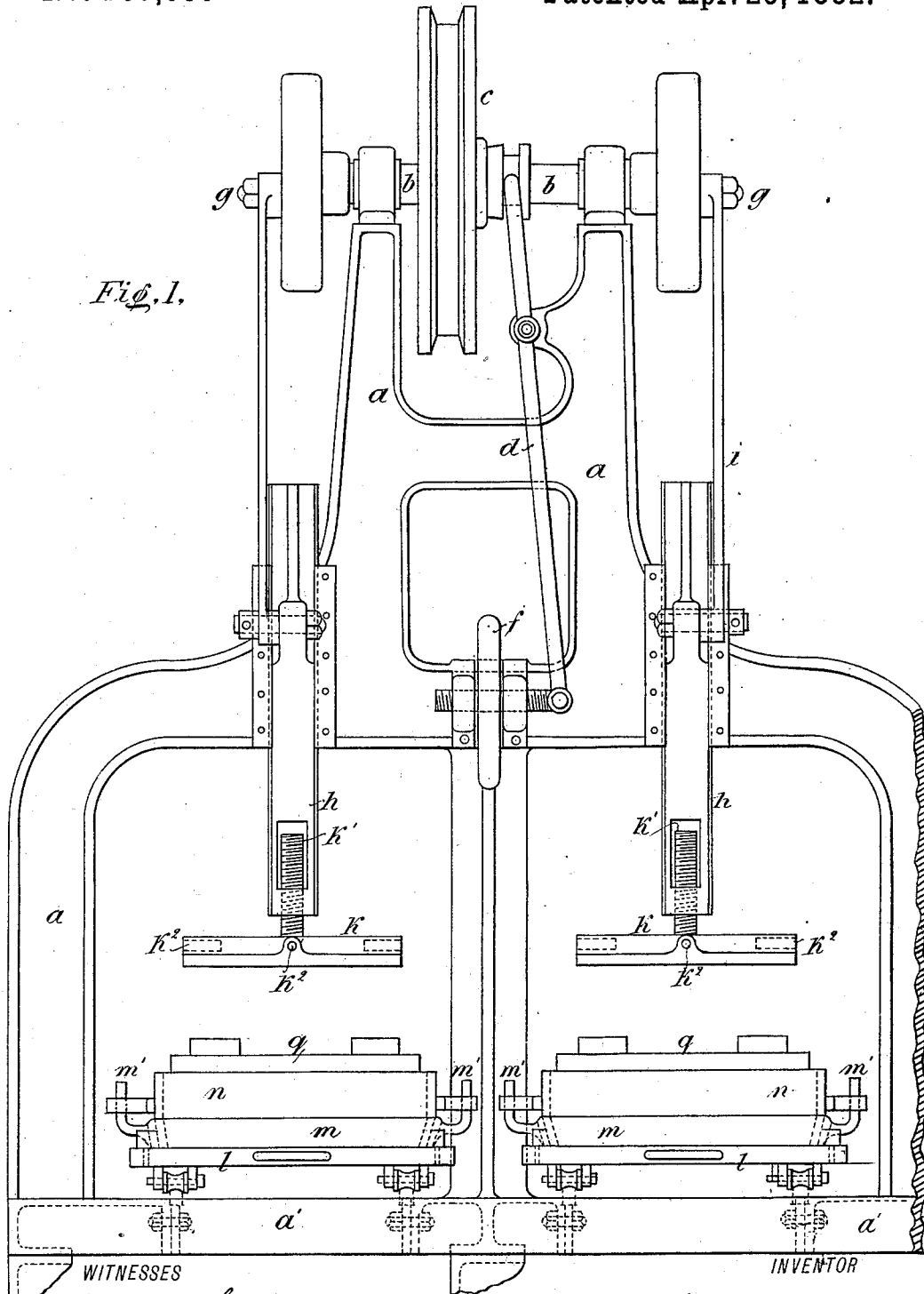

WITNESSES

Wm. A. Skunkle,
Stellie L. Holmes.

INVENTOR

Francis Ley.
 By his Attorneys,
Palmer, Hopkins & Peyton.

(No Model.)

2 Sheets—Sheet 2.

F. LEY.

SAND MOLDING MACHINE.

No. 257,030.

Patented Apr. 25, 1882.

Fig. 2.

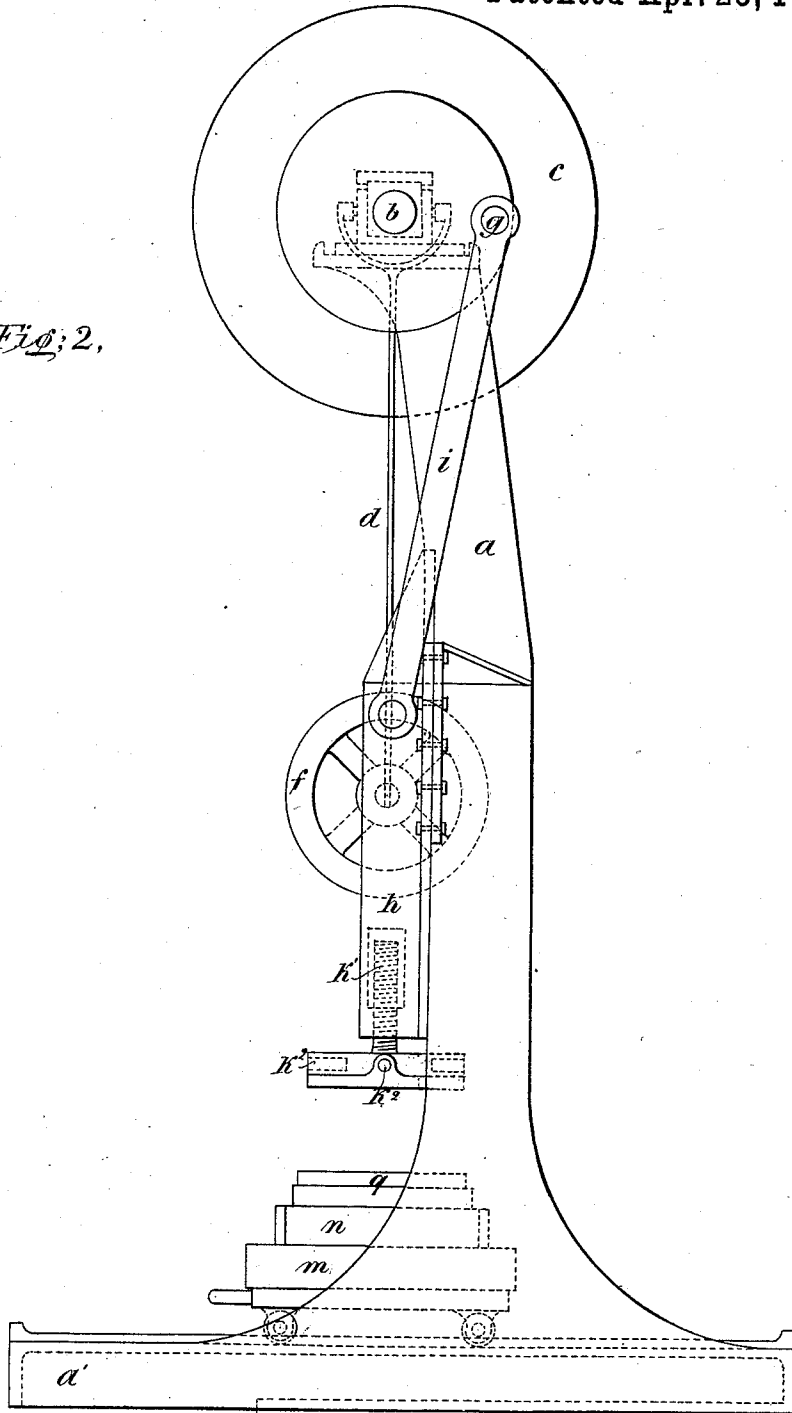

WITNESSES

Wm A. Skinkb.
Stellie L. Holmes.

INVENTOR

Francis Ley
By his Attorneys

Goldman, Hopkins & Taylor.

UNITED STATES PATENT OFFICE.

FRANCIS LEY, OF VULCAN IRON WORKS, DERBY, ENGLAND.

SAND MOLDING MACHINE.

SPECIFICATION forming part of Letters Patent No. 257,030, dated April 25, 1882.

Application filed February 13, 1882. (No model.) Patented in England June 21, 1881.

To all whom it may concern:

Be it known that I, FRANCIS LEY, a subject of the Queen of Great Britain, residing at the Vulcan Iron Works, Derby, England, have
5 invented certain new and useful Improvements in Machinery for Forming Molds of Sand or such like Material, (for which I have received Letters Patent in England, No. 2,725, dated June 21, 1881,) of which the following is a specification.
10

This invention has for its object improvements in machinery for forming molds of sand or such like material. The machine is designed for molding from plate-molds or from loose
15 patterns. The pattern to be molded is placed or fixed onto the upper surface of a metal plate, which is laid onto a truck or carriage that can be run on rails, so as to be brought below the ram of a press or moved out from
20 below it. The molding boxes or flasks are laid onto the metal plates, pins on the one entering sockets in the other. The boxes are filled with sand and the sand is leveled true with the top edge of the flask. Upon the top of the
25 sand is laid a wooden board with battens across it on the back or top surface. The width and length of the board are somewhat less than the inside of the flask, and the edges are preferably tapered or beveled, so that it may
30 the better enter the mold when forced downward into it. The ram of the press I make capable of moving upward and downward in vertical guides. To move it upward and downward I joint it by a connecting-rod to a crank-
35 pin on a shaft, to which a slow revolving motion is given by a grooved fly-wheel receiving a friction driving-chain. I also make provision for connecting the pressure-plate of the ram at different heights to allow for different
40 thicknesses of flasks, and this I do by providing a screw upon the upper surface of the pressure-plate, screwing into a socket in the ram. The wheel by which the driving-shaft receives its motion I make fast upon the shaft
45 by a friction-clutch, so that the shaft may readily be disconnected from it; or fast and loose pulleys may be used if the machine is driven by a belt. The machine is made double—that is, with two trucks or carriages and
50 two rams. The cranks for working the rams are at the two ends of a horizontal driving-shaft

mounted in bearings at the top of the frame. The driving wheel or pulley by which the shaft is driven is intermediate of the length of the shaft. The top half of a mold may thus be
55 formed upon one carriage while the bottom half is formed upon the other carriage.

In order that my said invention may be most fully understood and readily carried into effect, I will proceed to describe the drawings here-
60 unto annexed.

In the drawings, Figure 1 is a front elevation, and Fig. 2 is a side elevation, of a molding-machine constructed according to my invention.
65

a a is the frame of the machine. It carries the axis *b* at its upper part in suitable bearings. This axis is caused to rotate at a comparatively slow speed. As represented in the drawings, it has a V-grooved wheel, *c*, upon
70 it, and this is driven by an endless chain with V-projections upon it, that enter the groove. The wheel *c* is made heavy to act as a fly-wheel. It is loose upon the axis, but can be
75 clutched fast with it by a friction-clutch of ordinary construction operated by the lever *d*, the screw *e*, and the hand-wheel *f*. Two similar disks are fixed upon the axis *b* at its ends. In each there is a crank-pin, *g*.

h h are slides arranged to move vertically
80 upon the frame in dovetail guides. Each slide is connected with the corresponding crank-pin, *g*, by a connecting-rod, *i*. The slides *h h* at their lower ends carry pressure-plates *k k*, which are so fitted that they may easily be removed,
85 as for different sorts of work pressure-plates of various sizes may be required. The pressure-plates have screwed stems *k'* on their upper surfaces, which are received into corresponding sockets at the lower ends of the slides.
90 *k²* are holes to receive a rod or lever which is used in turning the pressure-plate round to adjust the height. These parts constitute the adjustable rammers. Beneath the rammers the frame at *a' a'* forms a bracketed support,
95 upon which are the carriages *l l*, and these can be pushed in under the rammers or drawn forward or backward from them, as the operator requires. Each carriage runs upon four wheels, and is guided by the frame. The plate *m* is
100 laid upon the carriage, and this plate has the pattern formed or fixed upon its face. The

plates *m m* will carry each a half-pattern, and then the two flasks rammed upon the plates go together and form a complete mold.

5 *n n* are the flasks. They have perforated lugs or sockets upon them, which fit onto pins projecting upward at *m' m'* from the edges of the plates *m m*.

10 In working the machine the operations are as follows: The pattern-plate being on the carriage and the flask over it, as the drawings represent, molding-sand is poured into the flask to fill it, and the excess of sand is removed by passing a strickle over the top of the flask. The board *q*, stiffened by cross-
15 pieces at the back, is then laid upon the sand in the flask. The carriage thus loaded is now run in under the rammer or pressure-plate *k*, which, descending, drives the board *q* into the flask and consolidates the sand. The previous
20 adjustment of the machine and the uniform filling of the flasks insure the proper amount

of pressure being uniformly given. The flasks, when removed from the machine, are put together, and a complete mold ready for casting is thereby formed.

25 Having thus described the nature of my said invention and the manner of performing the same, I would have it understood that what I claim is—

30 The adjustable rammer consisting of the axis *b*, crank *g*, connecting-rod *i*, slide *h*, with screw-socket at its lower end, and pressure-plate *k*, with screw-stem *k'*, entering the said screw-socket, substantially as described.

FRANCIS LEY.

Witnesses:

GEORGE WILLIAM REYNOLDS,
30 *Kedleston Road, Derby,*

JOHN WILLIAM ROWBOTHAM,
15 *Newland Street, Derby,*

Clerks with Mr. John Moody, Solicitor and Notary Public, Derby, England.