

July 28, 1953

H. LANG
OVERALL GARMENT

2,646,568

Filed Sept. 24, 1949

2 Sheets-Sheet 1

Fig. 1.

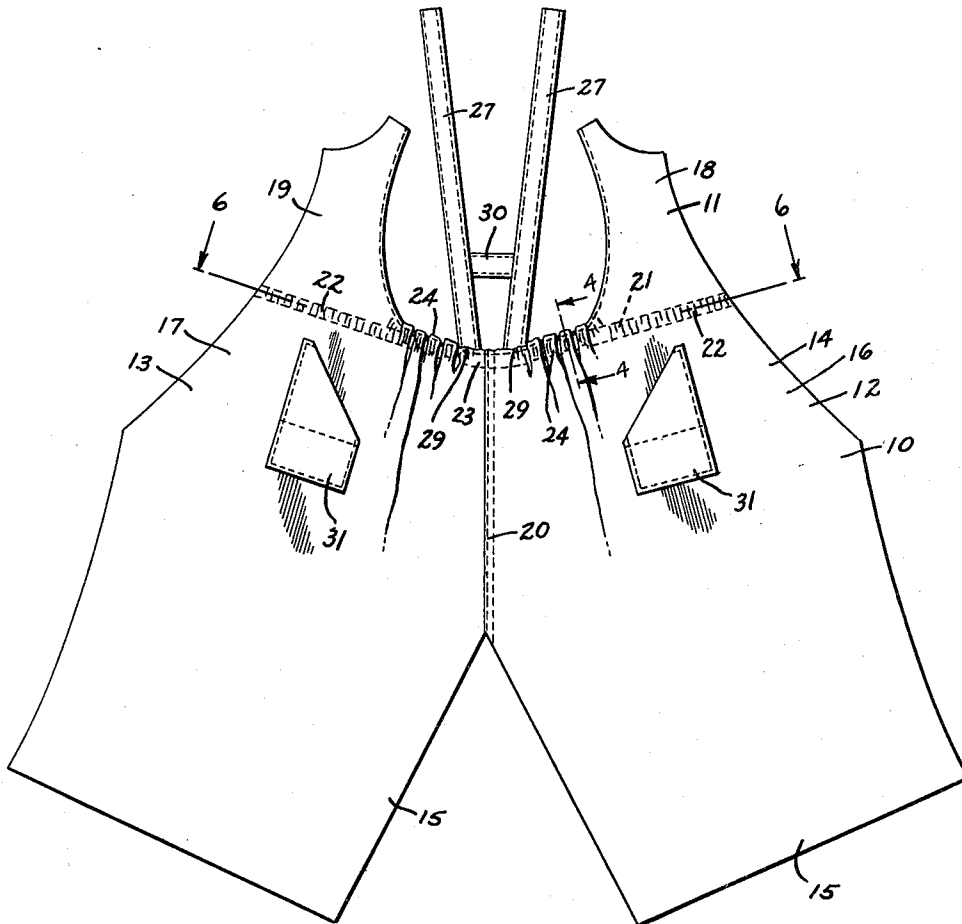
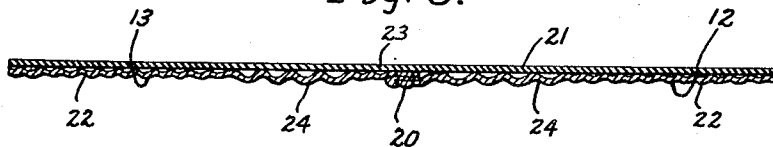

Fig. 6.



INVENTOR.
HARRY LANG
BY
S. H. Braddock
ATTORNEY.

July 28, 1953

H. LANG

2,646,568

OVERALL GARMENT

Filed Sept. 24, 1949

2 Sheets-Sheet 2

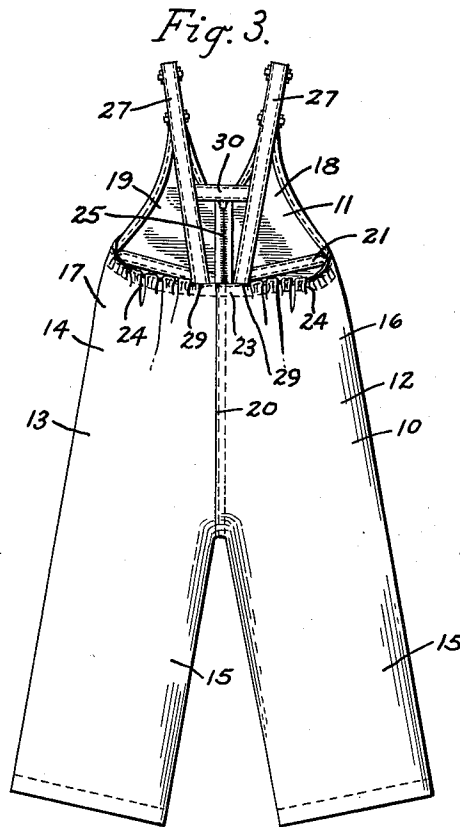
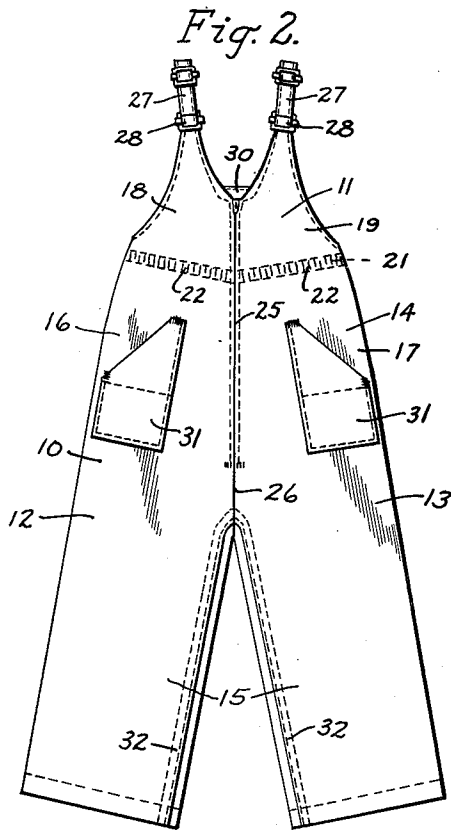

Fig. 4.

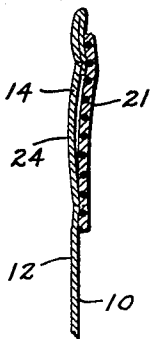
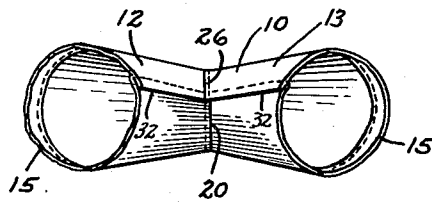

Fig. 5.



INVENTOR.
HARRY LANG
BY
Es. H. Braddock
ATTORNEY

UNITED STATES PATENT OFFICE

2,646,568

OVERALL GARMENT

Harry Lang, St. Paul, Minn.

Application September 24, 1949, Serial No. 117,671

1 Claim. (Cl. 2-80)

1

The invention herein presents a new and improved protective garment or overalls, of character especially suitable to be worn by children while at play, consisting of two pieces of material providing a trousers member and a bib member of the garment, and adjustable shoulder straps connected between upper extremities of spaced portions of the bib member at the front of the garment and spaced parts of said upper extremity of the body portion of said trousers member at the center of the rear of said garment.

In the accompanying drawings forming a part of this specification,

Fig. 1 is a plan view disclosing the exterior sides of the several elements of the garment as when spread out after manufacturing operations have been performed on said garment but before construction of the garment has been completed;

Fig. 2 is a front elevational view of the garment;

Fig. 3 is a rear elevational view of said garment;

Fig. 4 is a detail sectional view, taken on line 4-4 in Fig. 1;

Fig. 5 is a view of the garment as it would appear from the bottom of the sheet in Fig. 2 with the leg portions shaped as when said garment is being worn; and

Fig. 6 is a detail sectional view, taken on line 6-6 in Fig. 1.

A trousers member 10 and a bib member 11 of the garment of the invention are provided by but two pieces, denoted 12 and 13, respectively, of material, the one right and the other left, each extending longitudinally of said garment.

The trousers member 10 is constituted as a body portion 14 and leg portions 15, 15, said body portion consisting of intermediate parts, represented 16 and 17, respectively, of the longitudinally extending pieces 12 and 13 of material, and said leg portions each being composed as a lower part of one of said longitudinally extending pieces. The leg portions 15, 15 are independent of each other.

The bib member 11 is constituted as a pair of bib portions, indicated 18 and 19, integral with front portions of upper extremities of the intermediate parts 16 and 17, respectively, of said trousers member 10.

Adjacent marginal edges of the intermediate parts 16 and 17 of the trousers member 10 at the center of the rear of the garment are connected by a vertical seam 20 which extends between the

2

upper marginal edges of said intermediate parts and the crotch of said garment.

A band member 21, of elastic material as disclosed, encircles the upper marginal edge of the body portion 14, at the location of the upper extremities of said intermediate parts 16 and 17 of the trousers member, where the bib portions 18 and 19 and said upper extremities meet and are joined. Said band member is stitched, as at 22, 22, in substantially flatwise fashion to forwardmost portions of the intermediate parts 16 and 17 along substantially the full widths of the bib portions 18 and 19, and also stitched, as at 23, in substantially flatwise fashion to the rearwardmost portions of said intermediate parts at each side of the upper end of the vertical seam 20. The material of the intermediate parts 16 and 17 is puckered or shirred, as at 24, at locations disposed rearwardly of the garment, between the stitchings 22 and 23, and the puckered or shirred material is stitched to the band member 21 while the latter is flat, as indicated in Fig. 6 of the drawings.

Adjacent marginal edges of the bib portions 18 and 19, as well as adjacent marginal edges of upper portions of the intermediate parts 16 and 17 with which said bib portions are joined, are detachably connected by a vertical zipper 25 at the center of the front of the garment. Said vertical zipper extends downwardly from the upper end of the line of meeting between said bib portions to position above the crotch of the garment, and a vertical seam 26, extending from the vertical zipper to said crotch, connects lower portions of said intermediate parts 16 and 17 to each other.

The opposite side edges of the lower part of each of the longitudinally extending pieces 12 and 13, below the intermediate parts 16 and 17, are joined by a seam 32 which extends from the crotch to the lower end of the garment, thus to provide each leg portion 15. Said seams 32 are disposed forwardly of a plane passed centrally longitudinally through the garment and transversely through both of its leg portions, as will be clear from Fig. 5 of the drawings, and the lower ends of the vertical seams 23 and 23 are contiguous with the seams 32, 32 substantially at their location of meeting.

The bib portions 18 and 19 taper upwardly from their line of meeting at the vertical zipper 25. Adjustable shoulder straps 27, 27 are connected, as at 28, 28, between upper extremities of spaced portions of the bib member at the front of the garment and spaced parts 29, 29 of the upper extremity of the body portion 14 of the trousers members 10 at the center of the rear

of said garment. Stated otherwise, the spaced parts 29, 29 to which the adjustable shoulder straps 27 are secured are situated along the length of the stitching 23. A cross piece between the adjustable shoulder straps 27, 27, at the rear of the garment below the elevation of upper portions of the tapered parts of the bib portions, is designated 30.

Each of the longitudinally extending pieces 12 and 13 of material includes a first longitudinal side edge which has an upper concave portion, a central arcuate portion and a lower arcuate portion, and a second longitudinal side edge which has an upper arcuately cut portion extending substantially to the waist line of the corresponding panel, a central longitudinal portion which diverges generally with respect to the central portion of said first longitudinal side edge and a lower longitudinal portion which converges generally with respect to the lower arcuate portion of the first longitudinal side edge.

Pockets upon the intermediate parts 16 and 17, at the front of the garment, are indicated at 31.

Employment of but two pieces of material to provide the trousers member and the bib member in the manner as illustrated and described makes possible production of the protective garment or overalls at expense considerably less than would be required were said garment to include a greater number of pieces for producing said trousers member and bib member according to present practices.

The garment is loose fitting, and the construction and arrangement, including the band member 21 and the manner said band member is assembled with the longitudinally extending pieces 12 and 13, gives the desired shape to said garment. The "take-up" at and adjacent to the waist line, rearwardly of the garment at the opposite sides of the vertical seam 20, leaves the front of said garment without folds, in addition to imparting shape to the garment rendering it pleasing in appearance.

It will be evident that a garment made according to the invention is of practical and extremely simple construction.

What is claimed is:

A protective garment comprising a trousers member and a bib member integral therewith consisting of two single longitudinal pieces of material, said trousers member being constituted as a body member provided by intermediate parts and leg portions provided by lower parts of said longitudinal pieces and said bib member being constituted as a pair of bib portions integral with front portions of upper extremities of said inter-

mediate parts, each of said longitudinal pieces including a first longitudinal side edge having an upper concave portion, a central arcuate portion and a lower arcuate portion and a second longitudinal side edge having an upper arcuately cut portion extending substantially to the waist line of the corresponding panel, a central longitudinal portion which diverges generally with respect to the central arcuate portion of said first longitudinal side edge and a lower longitudinal portion which converges generally with respect to the lower arcuate portion of the first longitudinal side edge, said central portions of said second longitudinal side edges being secured together to form a vertical seam at the center of the rear of the garment uniting adjacent marginal edges of the intermediate parts providing the body portion of said trousers, intersections of the central and lower portions of said first and second longitudinal side edges forming the crotch point of the garment, lower central portions of said first longitudinal side edges being secured together to form a vertical seam at the center of the front of said garment, lower portions of the first longitudinal side edges being secured to lower portions of the second longitudinal side edges to provide inside leg seams, portions of the first longitudinal side edges between said upper concave portions and the upper central portions of said first longitudinal side edges being detachably connected to form a front closure extending downwardly from the top of said garment, and shoulder straps connected between upper extremities of said bib portions at the front of the garment and a part of said garment at the center of the rear thereof at the elevation of said upper extremities of the intermediate parts of said longitudinal pieces of material.

HARRY LANG.

References Cited in the file of this patent
UNITED STATES PATENTS

Number	Name	Date
1,000,812	Jacobs	Aug. 15, 1911
1,191,288	DeVoist	July 18, 1916
1,277,007	Weis	Aug. 27, 1918
1,333,958	Boardman	Mar. 16, 1920
1,737,882	Hatch	Dec. 3, 1929
2,418,050	Shank	Mar. 25, 1947

FOREIGN PATENTS

Number	Country	Date
438,714	Great Britain	Nov. 21, 1935