

(No Model.)

2 Sheets—Sheet 1.

H. W. ARMSTRONG.
RAIL BENDER.

No. 527,100.

Patented Oct. 9, 1894.

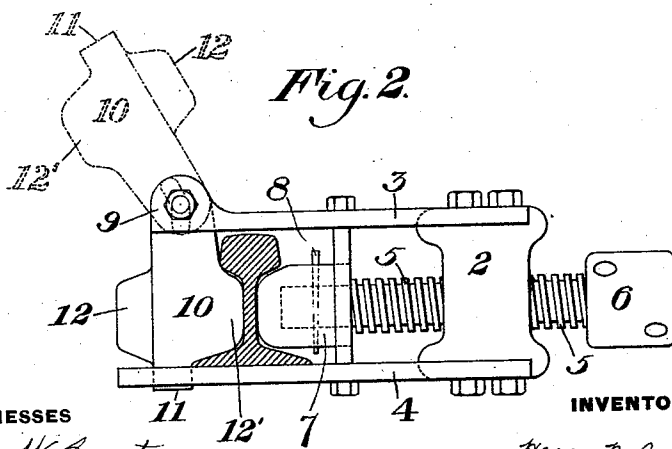
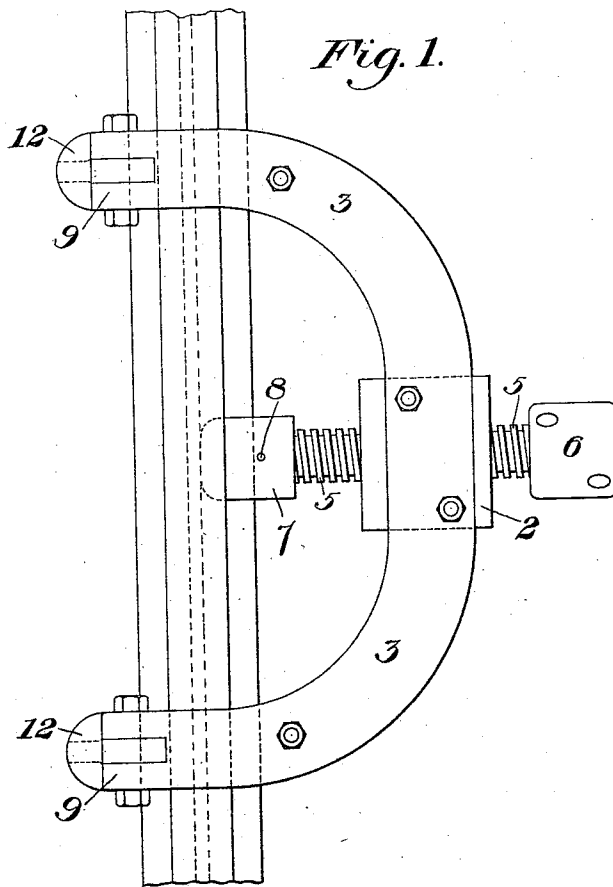

WITNESSES

Harren H. Swartz
H. M. Corwin

INVENTOR

Harry W. Armstrong
by W. Bakerwell, Jr.
his Attorneys

H. W. ARMSTRONG.
RAIL BENDER.

No. 527,100.

Patented Oct. 9, 1894.

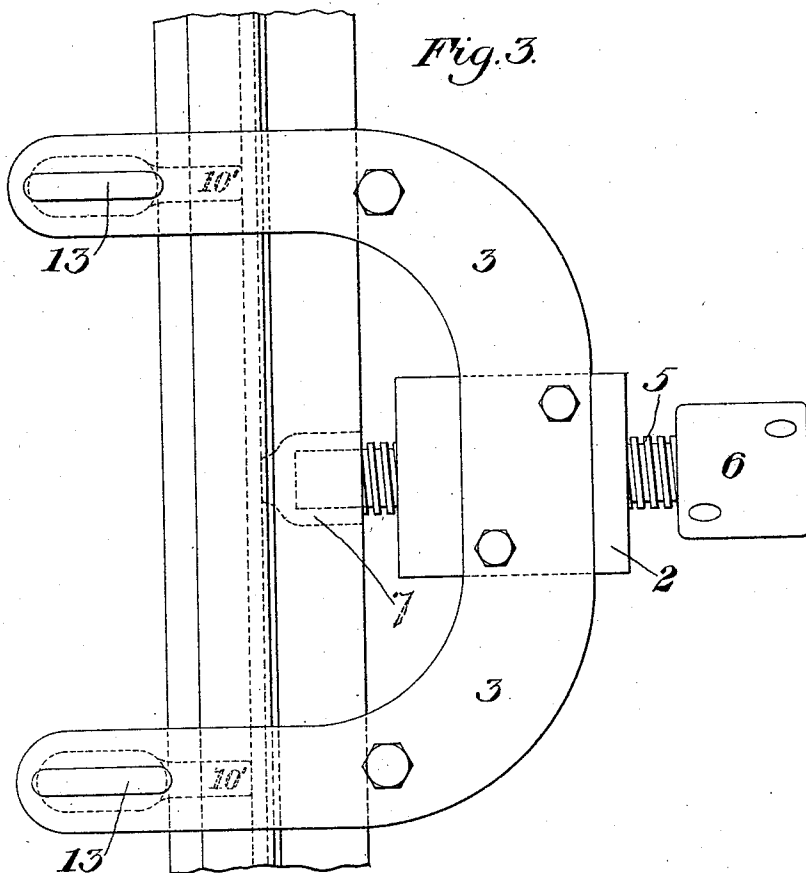

Fig. 3.

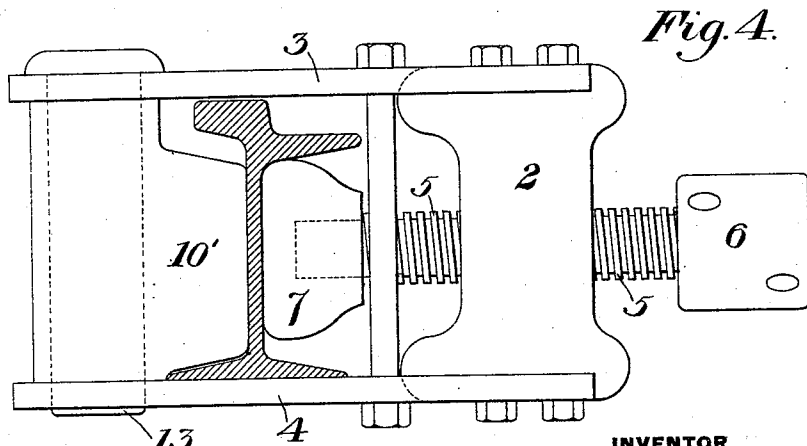

Fig. 4.

WITNESSES

Warren H. Swartz
H. M. Corwin

INVENTOR

Harry W. Armstrong
by T. Baker & Son
his Attorneys

UNITED STATES PATENT OFFICE.

HARRY W. ARMSTRONG, OF OAKMONT, PENNSYLVANIA.

RAIL-BENDER.

SPECIFICATION forming part of Letters Patent No. 527,100, dated October 9, 1894.

Application filed June 30, 1894. Serial No. 516,194. (No model.)

To all whom it may concern:

Be it known that I, HARRY W. ARMSTRONG, of Oakmont, in the county of Allegheny and State of Pennsylvania, have invented a new and useful Improvement in Rail-Benders, of which the following is a full, clear, and exact description, reference being had to the accompanying drawings, forming part of this specification, in which—

Figure 1 is a top plan view of my improved rail-bender applied to a rail. Fig. 2 is a side elevation of the same; and Figs. 3 and 4 are similar views of a modified form.

My invention relates to the devices employed for bending street-railway or other rails, and is designed to produce a bender which is more easily applied and removed, and does its work more effectually than former devices for this purpose.

In the drawings, 2 represents a casting, to the upper and lower faces of which are secured the correspondingly curved plates 3 and 4, the ends of which are designed to extend respectively above and below the rail to be bent. Through the casting 2 extends an innerly screw-threaded aperture in which fits the screw-shaft 5, provided at its outer end with an operating head 6, having holes for the insertion of a lever, while to its inner end a block 7 is removably held by means of a pin 8. Each end of the upper plate terminates in a pair of vertical lugs 9, between which is pivoted a bearing-block 10. Each block 10 is slotted for the passage of the pivot pin, and is provided at its lower end with a lug 11 arranged to enter a slot in the corresponding end of the lower plate. Both edges of the blocks 10 are provided with projecting portions 12 and 12' arranged to press against the web of the rail so that by removing the pivot-pin and reversing the block, it will fit another form of rail.

The operation is apparent. The bender being slipped over the rail, the blocks 10 are swung down and being lifted vertically, the slots, passing up over the pins, are dropped with their lugs in the slots of the lower plates, thus securing the blocks in place. Pressure is then brought as usual upon the intermediate portion of the rail by the screw-shaft 5.

In the modification of Figs. 3 and 4, the block 10' is removably held in position by a flat pin 13 passing through registering slots in the block and the upper and lower plates.

The blocks 10 and 7 may be removed and replaced with others as desired to fit the particular section of rail operated upon, and the block 10' may be provided with a projection upon the opposite side as in the former case.

The advantages of the invention are apparent. Instead of bringing the strain upon the head of the rail and distorting its shape when pressure is brought thereon, the pressure comes upon the web or central portion of the rail. The device can be easily and quickly applied and removed and adjusted to fit different sections of rails, while its construction is simple and compact.

Many changes may be made in the form, construction and arrangement of the parts without departure from my invention; since

What I claim, and desire to secure by Letters Patent, is—

1. A rail-bender having plates arranged to extend above and below the rail, bearing-blocks held between the ends of the plates, and means for applying pressure to the rail between the bearing-blocks; substantially as described.

2. A rail-bender comprising plates extending above and below the rail, bearing-blocks pivoted in the ends of the upper plate and arranged to be removably secured to the lower plate, and a screw-shaft for applying pressure to the rail; substantially as described.

3. A rail-bender comprising plates extending above and below the rail, bearing-blocks having slots through which extend pivot-pins upon the upper plates, the end-portions of the lower plates being slotted to receive the lower ends of the bearing blocks, and a screw-shaft for applying pressure; substantially as described.

4. A rail-bender comprising a casting having a screw-threaded shaft passing through, curved plates secured thereto and arranged to extend above and below the rail, and removable bearing-blocks held in their outer ends; substantially as described.

In testimony whereof I have hereunto set my hand.

HARRY W. ARMSTRONG.

Witnesses:

W. B. CORWIN,
H. M. CORWIN.