

P. T. DUNN.  
 ADJUSTABLE BALL CASTER.  
 APPLICATION FILED MAR. 21, 1911.

1,016,324.

Patented Feb. 6, 1912.

2 SHEETS—SHEET 1.

*Fig. 1*

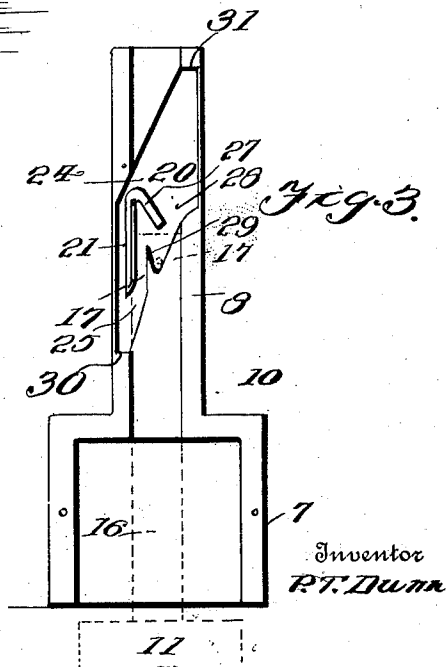
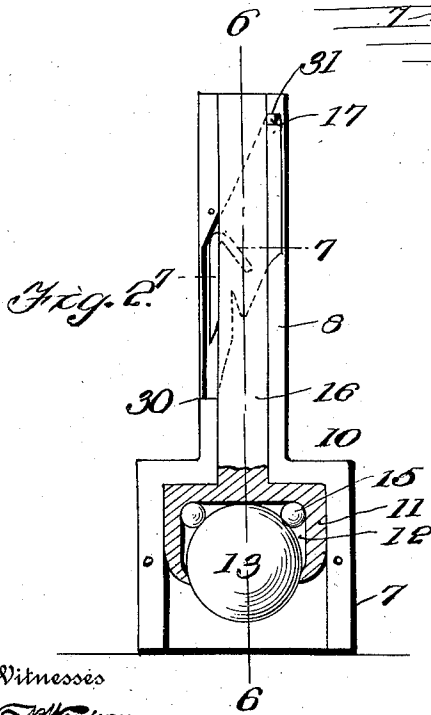
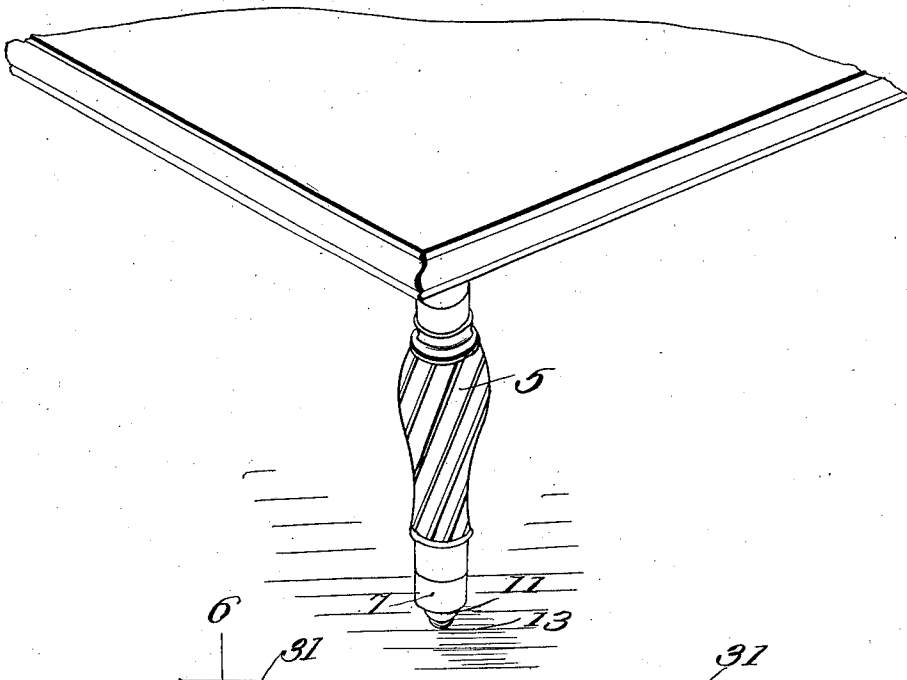

Witnesses  
*W. A. Woodson*  
*J. M. Fellin*

Inventor  
*P. T. Dunn*  
 By *H. A. Tracy* Attorneys.

P. T. DUNN.  
 ADJUSTABLE BALL CASTER.  
 APPLICATION FILED MAR. 21, 1911.

1,016,324.

Patented Feb. 6, 1912.

2 SHEETS—SHEET 2.

Fig. 4.

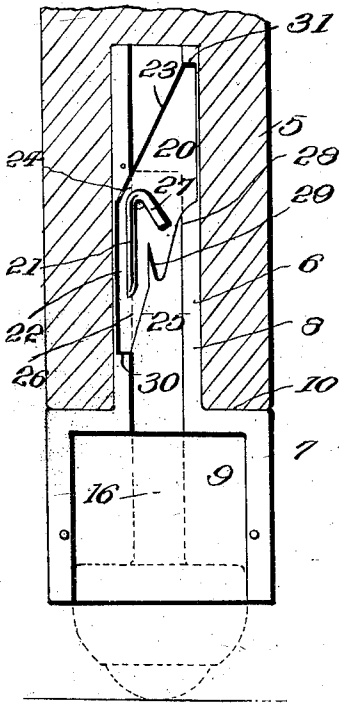

Fig. 5.

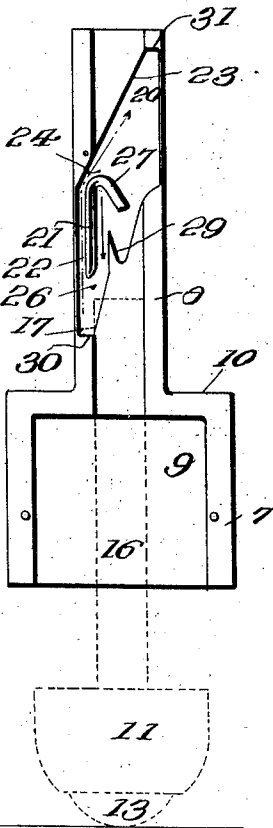

Fig. 6.

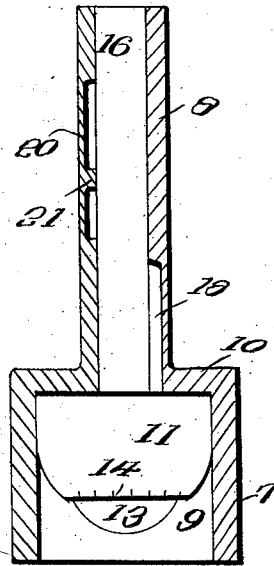

Fig. 7.

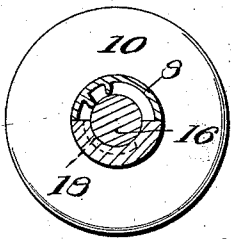
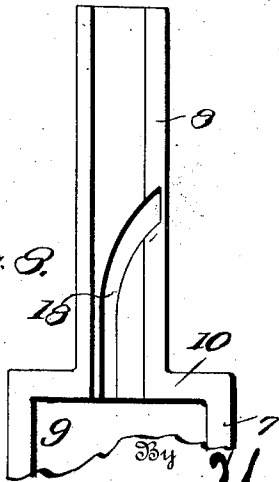

Fig. 8.



Inventor

P. T. DUNN.

Witnesses  
 W. N. Woodson

Jessie H. Fallin

H. A. Sawyer, Attorneys.

# UNITED STATES PATENT OFFICE.

PATRICK T. DUNN, OF CEDAR RAPIDS, IOWA.

## ADJUSTABLE BALL-CASTER.

1,016,324.

Specification of Letters Patent.

Patented Feb. 6, 1912.

Application filed March 21, 1911. Serial No. 616,001.

*To all whom it may concern:*

Be it known that I, PATRICK T. DUNN, citizen of the United States, residing at Cedar Rapids, in the county of Linn and State of Iowa, have invented certain new and useful Improvements in Adjustable Ball-Casters, of which the following is a specification.

This invention relates to casters and more particularly to a ball bearing caster especially designed for use in connection with beds, chairs, tables and other articles of furniture.

The object of the invention is to provide a caster of simple and durable construction, capable of being readily attached to the leg of a table or the like and which may be conveniently lowered in contact with the floor to facilitate moving the table from place to place or elevated above the floor so that said table may rest securely thereon.

A further object is to provide a caster, the construction of which is such that it will be concealed at all times except when in use, and which will permit an article of furniture to be easily moved from one portion of a room to another without danger of dragging, tearing or otherwise damaging the carpet.

A still further object of the invention is generally to improve this class of devices so as to increase their utility, durability, and efficiency.

Further objects and advantages will appear in the following description, it being understood that various changes in form, proportions and minor details of construction may be resorted to within the scope of the appended claims.

In the accompanying drawings, Figure 1 is a perspective view of a portion of a table provided with a caster constructed in accordance with my invention; Fig. 2 is a longitudinal sectional view of the caster removed from the table leg, showing the ball or caster in elevated position to permit the lower end of the casing to rest on the floor, and the lateral pin of the shank in engagement with the stop shoulder of the casing; Fig. 3 is a similar view, showing in dotted lines the ball or caster extended below the lower end of the casing and the pin of the shank in engagement with the stop finger preparatory to holding the caster in contact with the floor when moving an article of furniture; Fig. 4 is a similar view, showing

the stop pin of the shank bearing against the lower face of the adjacent stop finger and the ball or caster supporting the weight of the table so as to permit the table to be moved from place to place; Fig. 5 is a vertical sectional view, showing the pin of the shank in engagement with the lower stop shoulder on the casing preparatory to moving the ball or caster to the position shown in Fig. 6; Fig. 6 is a vertical sectional view taken at substantially right angles to Fig. 5 and showing the position assumed by the caster after the table leg has been lowered; Fig. 7 is a transverse sectional view taken on the line 7-7 of Fig. 2; Fig. 8 is a plan view of one of the casing sections, showing the construction of the spiral groove.

Corresponding and like parts are referred to in the following description and indicated in all the views of the drawings by the same reference characters.

The improved caster forming the subject matter of the present invention may be used in connection with various articles of furniture, such as chairs, tables, desks and the like, and by way of illustration is shown applied to a table of the ordinary construction, in which 5 designates one of the supporting legs having a longitudinal bore 6 formed therein and opening through the bottom thereof.

The device comprises a casing 7, preferably cylindrical in shape and provided with a tubular extension 8 adapted to fit within the bore 6 of the table or other article of furniture to which it is applied. The casing 7 is preferably formed in two sections having their adjacent longitudinal edges united in any suitable manner, said casing being provided with a chamber 9 and an annular shoulder 10 adapted to bear against the lower end of the leg 5. Slidably mounted within the casing, is a head 11 having a socket 12 formed therein for the reception of a ball or roller 13, the latter constituting the caster proper. The ball 13 is preferably retained within the socket 12, by crimping or bending the lower edge of the metal, as indicated at 14, although a threaded retaining ring may be employed for preventing accidental displacement of the ball 13, if desired. Suitable balls 15, are preferably interposed between the ball or roller 13 and the adjacent wall of the socket 12 in order to reduce friction between the parts.

Secured to or formed integral with the

head 11, is a shank 16, which latter projects within the tubular member 8 and is provided at its upper end with a laterally extending pin or stud 17.

5 Formed in the tubular portion 8 of one of the casing sections, is a spiral groove 18, the lower end of which opens into the chamber 9, while the upper end thereof communicates with a recess or depression 20 formed in the inner wall of the tubular portion of the mating casing section. Extending laterally from the tubular member at the depression 20, is a rib 21 defining a passage 22, the upper end of said rib being spaced from the upper inclined wall 23 of the recess 20 to form a passage 24 and the lower end of said rib being spaced from the lower inclined wall 25 of the recess to form a similar passage 26. The upper end of the rib 21 is inclined downwardly to form a stop finger 27, the free end of which is spaced from the adjacent wall of the depression 20 to form a passage 28, there being an auxiliary rib or stop finger 29 formed on the tubular member 8 immediately below the stop finger 27. The passage 26 terminates in a stop shoulder 30, which, by engagement with the pin 17, serves to limit the downward movement of the caster, while a similar shoulder 31, at the upper end of the tubular member 8, by engagement with said stop pin, serves to limit the upward movement of the caster.

When the caster is not in use, the ball or roller 13 is entirely housed within the chamber 9 with the pin 17 bearing against the upper stop shoulder 31, and with the lower end of the table leg 5 resting firmly on the floor.

In order to expose the roller 13 to permit a table or other article of furniture to be moved from place to place, it is merely necessary to elevate the table leg above the surface of the floor for a short distance, say about one inch, which allows the head 11 carrying the ball or roller 13, to project below the lower end of the casing 7, the pin 17 traveling in the depression 20 and passage 28 until it strikes the stop finger 29, as best shown in Fig. 3. The table leg is then lowered which causes the shank 16 to slide vertically within the tubular member 8 until the pin 17 engages the lower face of the stop finger 27, as shown in Fig. 4, and in which position, the table or other article of furniture, will be supported on the ball or roller 13 so as to permit the table to be conveniently moved from one portion of a room to another without danger of dragging, tearing or otherwise damaging the carpet.

In order to house the head 11 and ball 13 within the chamber 9 and thus permit the table leg to rest firmly on the floor, it is merely necessary to raise the table leg, say about two inches above the surface of the floor which allows the shank 16 to drop and

the pin 17 to travel in the passage 26 until the downward movement thereof is limited by engagement with the shoulder 30, as shown in Fig. 5, when by lowering the table leg, the pin 17 will travel upwardly within the passages 22 and 24 to the upper stop shoulder 31, the pin 17 being guided in its passage to the shoulders 30 and 31 by engagement with the inclined walls 25 and 23 of the depression 20 in the tubular member, as will be readily understood.

Particular attention is here called to the fact that when the caster is not in use, the head 11 and ball 13 thereof are entirely housed within the chamber 9 of the casing, so as not to present an unsightly appearance, and also to permit the lower end of the leg of a table to rest firmly on the floor and thus prevent wobbling or accidental displacement of said table.

While the casing 7 is preferably formed in two sections, it will of course be understood that said casing may be made integral, if desired, and that a roller, wheel or other anti-friction device may be mounted in the socket of the head 11, without departing from the spirit of the invention. It will also be understood that the casters may be made in different sizes and shapes according to the articles of furniture upon which they are used.

Having thus described the invention, what is claimed as new is:

1. A device of the class described including a casing, the interior wall of which is provided with upper and lower shoulders, there being spaced oppositely disposed stop fingers arranged between said shoulders, a shank slidably mounted within the casing, a caster carried by the shank, and a pin extending laterally from the shank for engagement with the shoulders, said pin being also movable into engagement with the stop fingers.

2. A device of the class described including a casing, the interior wall of which is provided with a depression defining upper and lower shoulders and having spaced oppositely disposed stop fingers arranged between said shoulders, there being a spiral groove formed in the casing and communicating with the depression, a shank mounted for sliding movement within the casing, a caster carried by said shank, and a pin extending laterally from the shank for engagement with said shoulders, said pin being also movable into engagement with the stop fingers.

3. A device of the class described including a casing, the inner wall of which is provided with upper and lower shoulders, a rib extending laterally from the inner wall of the casing and forming a stop finger, a second stop finger arranged opposite the first stop finger, a shank slidably mounted with-

in the casing and provided with a caster, and a pin extending laterally from the shank for engagement with the upper and lower shoulders, said pin being also movable into engagement with the stop fingers.

5 4. A device of the class described including a casing, the inner wall of which is provided with a depression defining upper and lower shoulders, there being a groove  
10 formed in the casing and communicating with said depression, a stop finger arranged within the depression, a vertical rib having its upper end extended downwardly over  
15 stop finger, a shank slidably mounted within the casing, a caster carried by the shank,

and a pin extending laterally from said shank and adapted to engage one of the stop fingers when the caster is elevated above a support and to engage the other stop finger when a weight is supported by the caster, said pin being movable into engagement with the lower shoulder to permit the shank to slide vertically within the casing and allow the pin to bear against the  
25 upper shoulder.

In testimony whereof, I affix my signature in presence of two witnesses.

PATRICK T. DUNN. [L. s.]

Witnesses:

L. M. HULL,  
MARIE C. NOVACK.

---

Copies of this patent may be obtained for five cents each, by addressing the "Commissioner of Patents, Washington, D. C."

---