

(No Model.)

2 Sheets—Sheet 1.

J. HOBSON.

PILE WIRE MOTION FOR LOOMS.

No. 281,069.

Patented July 10, 1883.

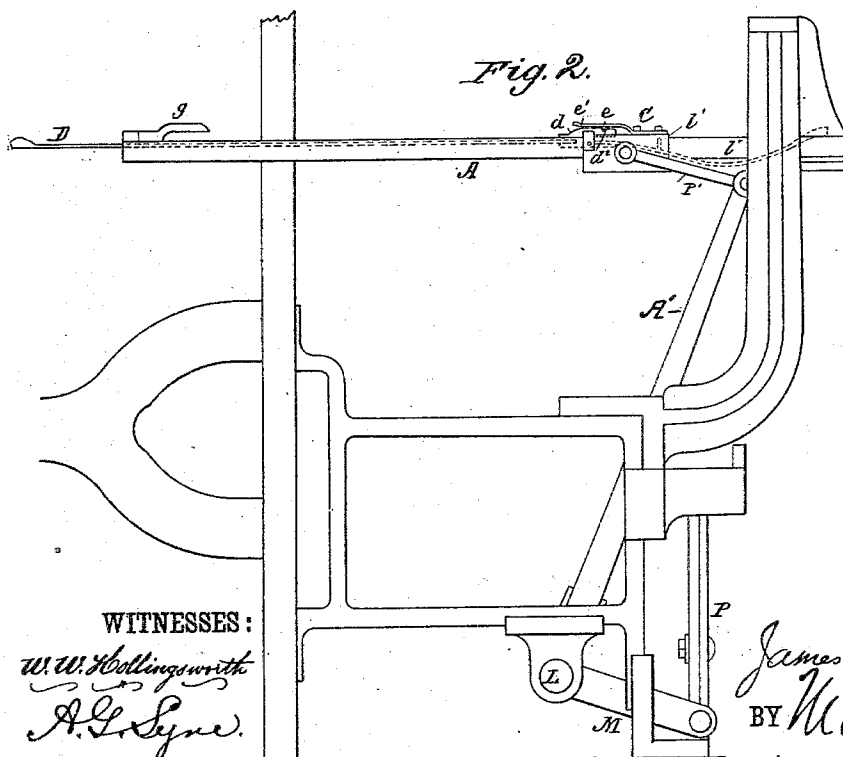
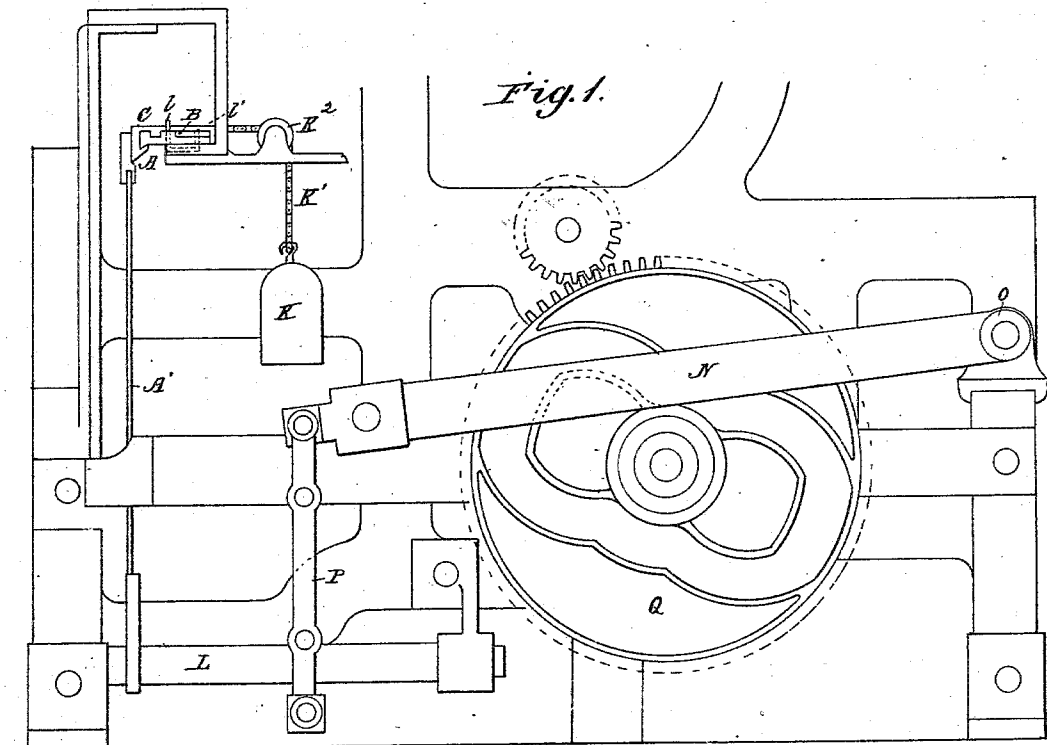

WITNESSES:
W. W. Hollingsworth
A. L. Lyne

INVENTOR:
James Hobson
BY *Wm. L.*

ATTORNEYS.

(No Model.)

2 Sheets—Sheet 2.

J. HOBSON.

PILE WIRE MOTION FOR LOOMS.

No. 281,069.

Patented July 10, 1883.

Fig. 3.

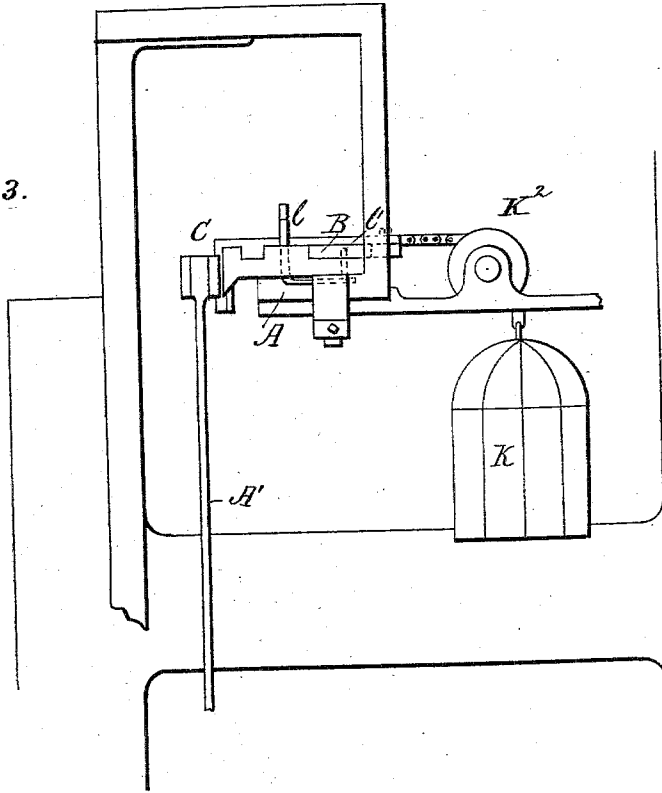

Fig. 5.

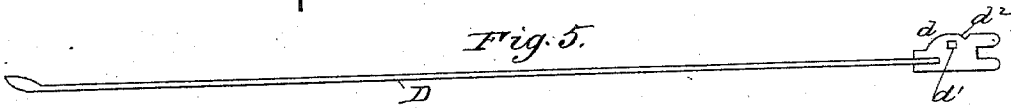
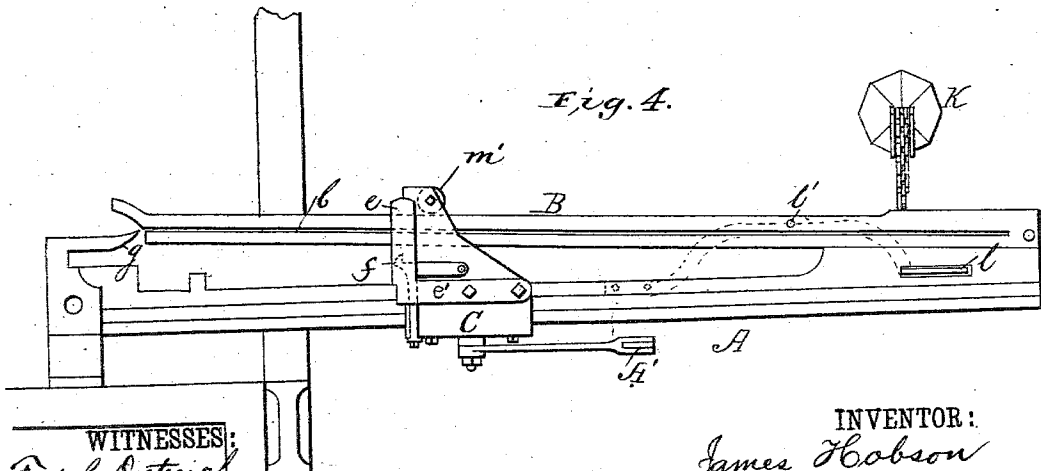

Fig. 4.



WITNESSES:
Fred. G. Dietrich
A. G. Syne

INVENTOR:
James Hobson
 BY *Russell*
 ATTORNEYS.

UNITED STATES PATENT OFFICE.

JAMES HOBSON, OF BURY, NEAR MANCHESTER, ENGLAND, ASSIGNOR TO
SAMUEL S. HALL, OF SAME PLACE.

PILE-WIRE MOTION FOR LOOMS.

SPECIFICATION forming part of Letters Patent No. 281,069, dated July 10, 1883.

Application filed March 31, 1882. (No model.)

To all whom it may concern:

Be it known that I, JAMES HOBSON, of Bury, near Manchester, England, have invented a new and useful Improvement in Pile-Wire Motions for Looms, of which the following is a full, clear, and exact description, reference being had to the annexed drawings, forming part of this specification.

This invention relates to looms for weaving pile fabrics, including Brussels carpets, looped goods, seal-skins, Utrecht velvet, slipper-cloths, plush, and other similar fabrics; and the invention consists of the novel construction hereinafter described and claimed.

In the drawings, Figure 1 is an end elevation of a loom, partly broken away, showing means for operating the pile-wire carriage. Fig. 2 is a front elevation of the same end of the loom, partly broken away, showing the means for operating the carriage as seen from another point of view. Fig. 3 is an end elevation of the pile-wire carriage, track, and transferring-switch and their connections. Fig. 4 is a plan view of the same, and Fig. 5 is a view of the pile-wire.

The stationary track A, upon which slides the carriage for inserting the pile-wires into and withdrawing them from the fabric being woven, is provided with an oscillating switch, B, which is pivoted to the outer end of the track in such manner that it shall be capable of movement to and from the carriage-track to receive and properly transfer a newly-withdrawn pile-wire into proper position for re-entrance into the fabric.

The switch B is provided with a longitudinal groove, *b*, which is of sufficient length to receive the whole length of a pile-wire, the latter being drawn into the groove endwise by means of the carriage C.

Each pile-wire D is provided with a head, *d*, having a recess, *d'*, in the upper surface thereof, into which fits an arm, *e*, on the spring *e'* of the carriage. A beveled stationary projection, *g*, formed on the inner end of the track, is adapted to lift the spring, *e'*, when the spring or its arm is moved into contact with the upper surface of the projection at the limit of the inward movement of the pile-wire carriage, to release the head of the wire engaged thereby, after the latter has been inserted into the shed.

The carriage is also provided with a spring-catch, *f*, which is adapted to enter an eye, *d*, in the head of a wire in the fabric, when the carriage is moved to the inner end of the track, and which withdraws the wire into the groove in switch B in the next outward movement of the carriage. When the arm *e* slips off the projection *g* in the outward movement of the carriage, it springs into the notch *d''* in the head of the wire engaged by the hook *f*, and remains in engagement therewith until the wire is again inserted between the warps of the fabric. When the carriage reaches the outer end of the track, the movement of the switch from the track to a position for inserting the wire disengages the wire from catch *f* and leaves it under the control of arm *e*.

The reciprocating movement of the carriage C, above described, is to be effected by a lever, A', which is oscillated with the shaft L (to which it is connected) by means of a lever, N, pivoted at O, and connected to the shaft L by the rod P and arm M. The lever N is operated by a cam-wheel, Q, driven by a pinion on the crank-shaft. As the cam revolves, the lever A' rocks with the shaft L, and moves the carriage along the track by means of a rod, P', connecting the said lever with the carriage.

The means for moving the switch B to a position for inserting a pile-wire into the shed consists of a weight, K, which is suspended by a chain, K', connected to the switch near its outer end, and passed over a pulley, K². To prevent the weight from acting upon the switch while a wire is being drawn into the latter, I provide a spring, *l*, at the outer end of the track, which is arranged to engage with the switch, and is adapted to be depressed by the carriage to release the switch as soon as the wire has been withdrawn. This spring projects at its outer end above the surface of the track through an opening therein, and engages with the switch by means of a pin, *l'*, which is adapted to enter a vertical perforation formed in the body of the switch. As the carriage is passed to the inner end of the track, a guide-roller, *m'*, on the carriage, acting upon the outer side of the switch, will cause the switch to return into position for receiving another wire, and as soon as it is in said posi-

tion the pin *l* on the spring will again enter the perforation in the switch and retain the latter in position until the spring *l* is again depressed by the carriage at the end of the outward movement of the latter.

5 What I claim is—

The combination of the stationary track having a spring at its outer end provided with a pin, and having one end projecting
10 above the upper surface of the track with the switch having a perforation, with which said pin is adapted to engage, the carriage having

a guide-roller in contact with the outer side of the switch, and adapted to depress the spring to withdraw the pin from the switch, the weight
15 connected to the switch, and means for operating the carriage, substantially as shown and described.

JAMES HOBSON.

Witnesses:

SAMUEL STANDRING HALL,
Hope Foundry, Bury.

ARTHUR C. HALL,
U. S. Consul at Manchester, England.